

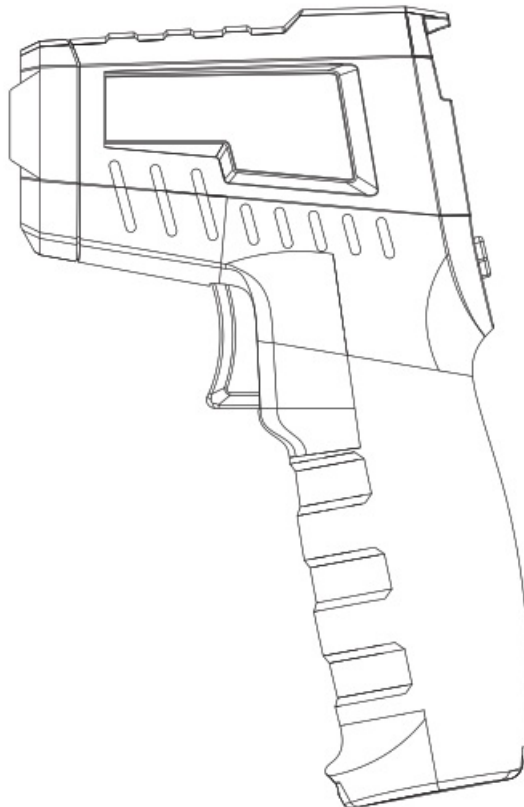

UNI-T UT306S Infrared Thermometer User Manual

[Home](#) » [UNI-T](#) » UNI-T UT306S Infrared Thermometer User Manual 

UNI-T®



P/N:110401110301X
UT306S Infrared Thermometer User Manual

Contents

- [1 Overview](#)
- [2 Safety Instructions](#)
- [3 Technical Indexes](#)
- [4 Operating instructions](#)
- [5 Maintenance](#)
- [6 Troubleshooting](#)
- [7 Documents / Resources](#)
- [8 Related Posts](#)

Overview

UT306\$ infrared thermometer (hereinafter referred to as the thermometer) can quickly and accurately determine the surface temperature of the target by measuring the infrared energy radiated by the target surface, which is suitable for non-contact temperature measurement. UT306S is a thermometer with a D: S ratio of 12:1.

Safety Instructions



Warning: In order to prevent eye damage or personal injury, please read the following safety instructions before using the product:

- Do not point the laser directly at persons or animals or indirectly through reflective surfaces.
- Do not look directly at the laser or with optical tools (binoculars, microscopes, etc.).

LASER RADIATION DO NOT STARE INTO BEAM CLASS 2 LASER PRODUCT A=630-670nm,<1mW, EN60825-1:2014



Cautions:

- If the laser irradiates the user's eyes, please close the eyes immediately and turn the head away.
- Do not disassemble or refit the product and laser without permission.
- To ensure its safety and accuracy, this product should only be repaired by professional maintenance personnel using original replacement parts.
- Replace the batteries when the low battery Indicator shows to prevent incorrect measurements.
- Please check the product before using it. If it is damaged, cracked on the surface or missing plastic parts, do not use it.
- Please refer to the emissivity information for the actual temperature. Highly reflective objects or transparent materials will make the actual temperature higher than the measured temperature.
- When measuring these objects, pay attention to the risk of burns.

- Do not use the product in an environment with flammable and explosive liquid, gas or dust.
- Do not use the product around the environment with steam, dust, or large temperature fluctuations.
- It may bring inaccurate results and risks.
- Put the product in the current environment for more than 30 minutes before using it to ensure measurement accuracy.
- Do not leave the thermometer on or near objects of high temperature.

Technical Indexes

Model	UT306S
Optical resolution	12:1 (calculated at 95% energy)
Measurement range	-50°C-580t (-58 F-932 F)
LCD size	25'26mm
LCD display	TN-LCD
Accuracy	-50°C-0°C: $t(2t+0.VC/C)$ 0°C-500°C: $t\ 2'C$ or $t\ 2\%$ (whichever is greater)
	-58°F-32°F: $t(4.0°F+0.1°FPF)$ 32°F-932°F: $t\ 4.0°F$ or $t\ 2\%$ (whichever is greater)
Temperature index	$t0.1'Crt$ or $t0.1\%fC$ whichever is greater ($t0.1'FfF$ or $t0.1\%/' F$ whichever is greater)
Repeatability	$t0.5C$ or $t0.5\%$ whichever is greater ($1'F$ or 0.5% whichever is greater)
Emissivity	0.1-1.0 (adjustable. 0.95 by default)
Response time	:-C.250ms (95% of reading)

Spectral response	8um-14um
Auto power off	15s
Low battery indication	✓
High/low temperature LED alarm	✓
High/low-temperature sound alarm	✓
Data hold	✓
Unit conversion (C/F)	✓
MAX/MIN/AVG/DIF	✓
Lock measurement	,/
Laser	Single point laser, wavelength: 630nm–670nm. output power<1mW. type: class 2
Operating temperature	0C-50-C (32-F-122°F)
Storage temperature	-29C-60C (4 F-140 F)
Operating humidity	<90%RH (non-condensing)
Drop-proof	1m
Battery type	2'AAA (zinc-manganese batteries)
Battery life	a6h (continuous measurement mode with laser and backlight on)
Product color	Red + grey
Product weight	161.5g
Product size	146 x 94.5x46mm

Reference Standard: JJG 856-2015

Appearance



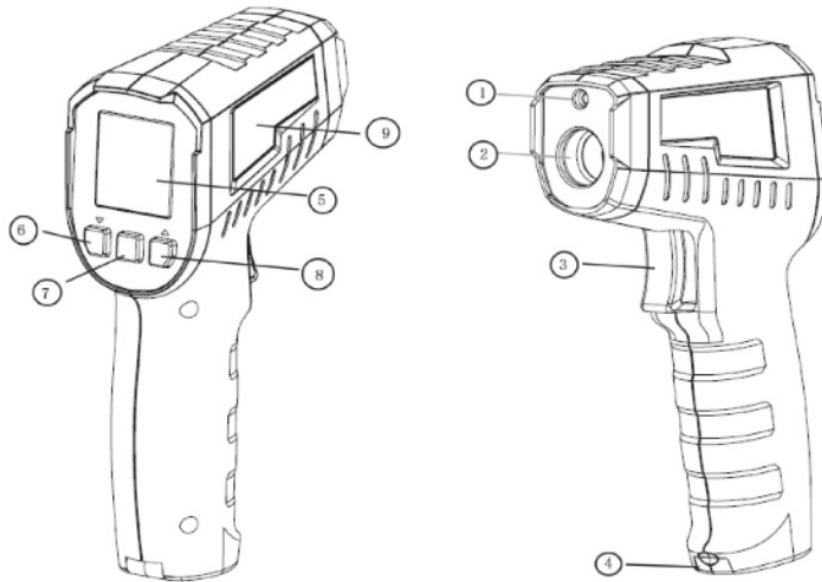

1	Laser
2	Infrared receiving window
3	Trigger
4	Battery door
5	LCD display
6	LOCK button
7	MODE button
8	LASER button
9	Laser warning label



Characteristics

1. With single point laser, making the measurement indication area more accurate
2. Bright, easy-to-read and high-contrast color EBTN display
3. MAX/MIN/AVG/DIF hold 4) With buzzer sound alarm, can quickly find abnormalities
4. Trigger lock, suitable for processes that require temperature monitoring
5. Short press the "  a button in shutdown mode to take a measurement

LCD Indicators

	Trigger lock	
	Buzzer	
HOLD	Temperature hold	
	Low battery	
$\epsilon = 0.88$	Emissivity	
MAX MIN AVG DIF	Measurement mode	
HI LO	Temperature alarm	
	Laser	
SCAN	Temperature measurement	
°C °F	Temperature unit	
8888	Temperature main display	
8888	Temperature secondary display	

Operating instructions

Startup

Short press (less than 0.5s) the trigger to turn on the thermometer, and the measured value before the last shutdown will be displayed. Pressing the MODE button can view MAX/MIN/AVG/01F.



Shutdown

The thermometer will automatically shut down after 15 seconds without any operation in the HOLD mode, and save the current measured value.

Manual Measurement

1. After aiming at the measured object, press the trigger and hold it. When the SCAN symbol is flashing, it means that the temperature is being measured, and the measurement result will be updated on the LCD.
2. Release the trigger, the SCAN symbol will disappear while the HOLD symbol will be displayed. The thermometer will stop measuring the temperature and keep the last measured value.

Lock Measurement

1. Short press the LOCK button to enter the lock measurement mode. The  symbol will be displayed on the LCD and the SCAN symbol will flash. The thermometer will measure the target temperature continuously without pressing the trigger all the time.
2. Press the trigger or short press the LOCK button again, the  and SCAN symbols will disappear while the

HOLD symbol will appear. The thermometer will stop measuring and keep the last measured temperature.

- Short press the LOCK button in the shutdown state to wake up the thermometer and enter the lock measurement mode.
- If the LOCK button is pressed and not released for more than 3 seconds, it will be regarded as a misoperation.

Note: The measured target should be greater than 2 times the thermometer light spot diameter (S), and then the test distance (D) can be determined according to the D: S relationship diagram. For example: when the user uses UT306S to measure the temperature of an object with a diameter of about 4" (10cm), the most accurate spot diameter (S) of the thermometer is about 2" (5cm), and then it can be estimated based on the D:S relationship diagram that the measuring distance (D) is about 24" (60cm).

MAX/MIN/AVG/DIF Value

Short press the "MODE" button to switch among "MAX-MIN-PAVG-PDIF" measurement modes in sequence and the temperature of the corresponding mode will be displayed in the secondary display position (as shown below).

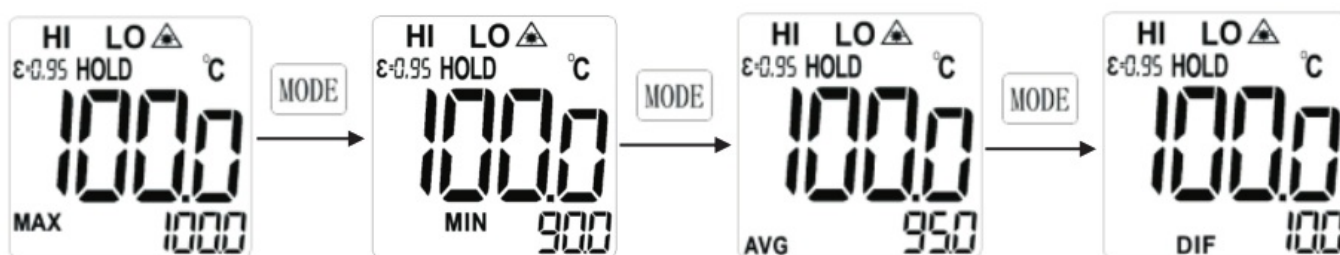

Laser Indicator

Pressing the S button can turn on/off the laser indication function. When it is turned on, the laser symbol AL will show on the LCD. and the laser will accurately indicate the measured position. Note: Please follow the cautions when fuming on the laser to avoid eyes injury.

High and Low-Temperature Alarm

If the measured temperature is higher than the set high alarm limit, the HI symbol on the display will flash. if the sound alarm is turned on, the buzzer will beep. If the measured temperature is lower than the set low alarm limit, the LO symbol will flash. If the sound alarm is turned on, the buzzer will beep. If the measured temperature value is within the range of high and low alarm limit, the HI/LO symbol will not show on the display.

Function Settings

In the HOLD interface, long press the "MODE" button for more than 2s to enter the high alarm limit-low alarm limit-emissivity-temperature unit-sound alarm and other function settings. Under these setting interfaces, the user can return to the HOLD interface by pressing the trigger or no operation for 10s.

High Alarm Limit Setting

In the HOLD interface, long press the "MODE" button to enter the high alarm limit setting interface. The user can use '▼' or '▲' to adjust. Short pressing will add or subtract 1 to the value each time, and long pressing will add or subtract 10 each second.

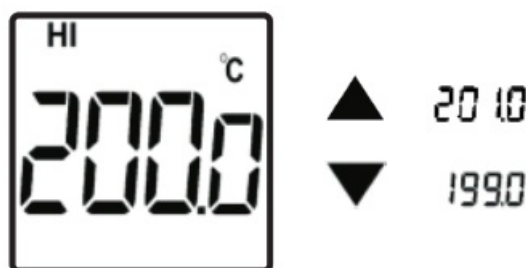

Low Alarm Limit Setting

In the HOLD interface, long press and then short press the "MODE" button once to enter the low alarm limit setting interface. The user can use '▼' or '▲' to adjust. Short pressing will add or subtract 1 to the value each time, and long pressing will add or subtract 10 each second.

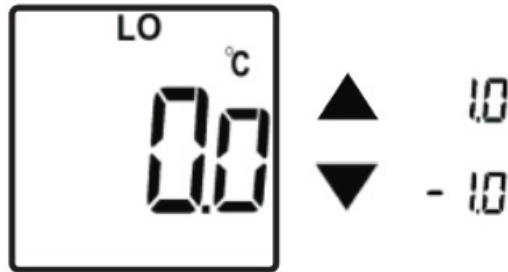

Emissivity Setting

In the HOLD interface, long press the “MODE” button once and then short press the “MODE” button twice to enter the emissivity setting interface. The user can use “▼” or “▲” to adjust. Short pressing will add or subtract 0.01 to the value each time, and long pressing will add or subtract 0.1 each second.

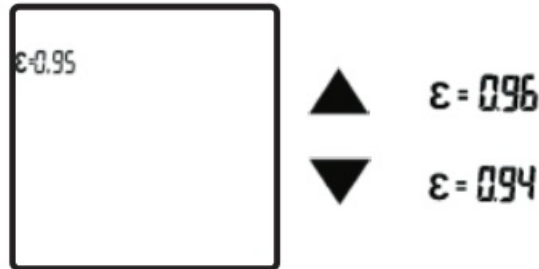

Temperature Unit Setting

In the HOLD interface, long press the “MODE” button once and then short press the “MODE” button three times to enter the temperature unit setting interface. The user can use “▼” or “▲” to convert the unit °C/°F.

Sound Alarm Setting

In the HOLD interface, long press the “MODE” button once and then short press the “MODE” button four times to enter the sound alarm setting interface. The user can use “▼” or “▲” to turn on/off this function.

D: S (Distance to Spot Ratio)

As the distance (D) between the thermometer and the measured target increases, the light spot diameter (S) of the measured area also increases. The relationship between measurement distance and light spot diameter is shown in the figure below.

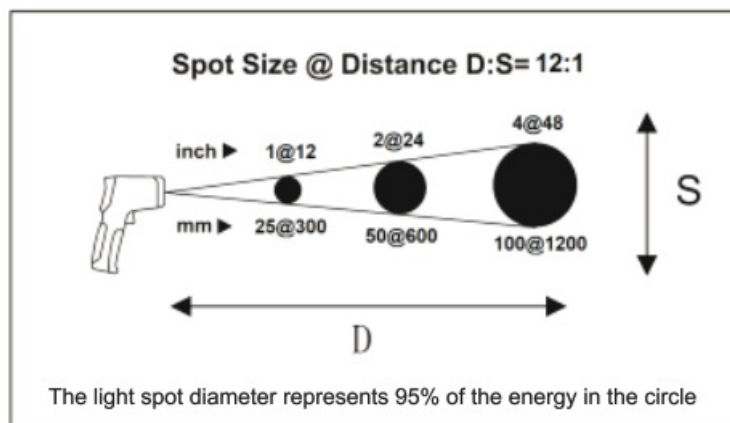

Field of View

When measuring, make sure that the measured target is larger than the light spot diameter. The smaller the target, the closer the test distance should be (refer to D: S for the detailed light spot diameter). It is recommended that the measured target be larger than twice the light spot diameter of the thermometer.

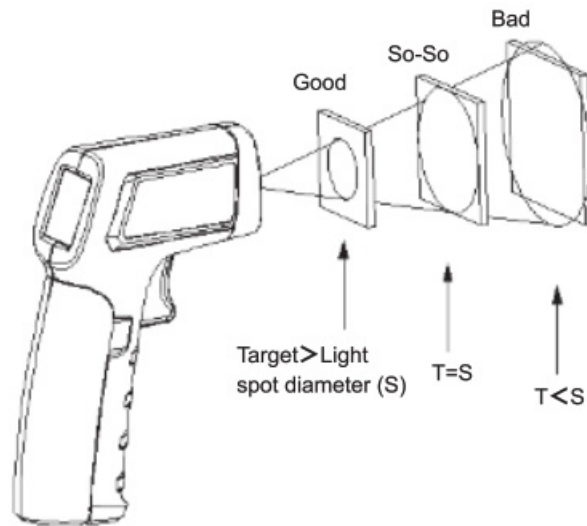

Emissivity

represents the material energy radiation. The emissivity of most organic materials, painted or oxidized surfaces is about 0.95. The user can use masking tapes or flat paints to cover the metal surface, use the high emissivity setting, and then wait for a period of time to make the surface temperatures of the tapes/flat paints and the covered object the same. At this point, the surface temperature of the tapes /flat paints is equal to the metal surface temperature. The following table shows the total emissivity ϵ of some metals and non-metals.

Measured surface	Emissivity
Metals	
Aluminum Oxide	0.2-0.4
A3003 Alloy Oxide Crude	0.3 0.1-0.3
Brass Polishing Oxide	0.3 0.5
Cuprum Oxide Electrical terminal board	0.4-0.8 0.6
Hastelloy Alloy	0.3-0.8
Inconel Oxide Abrasive blasting Electropolishing	0.7-0.95 0.3-0.6 0.15

Ferrum Oxide Rusting	0.5-0.9 0.5-0.7
Ferrum (casting) Oxide Non-Oxide Casting	0.6-0.95 0.2 0.2-0.3
Ferrum (forging) Passivating	0.9
Plumbum Crude Oxide	0.4 0.2-0.6
Molybdenum Oxide	0.2-0.6
Nickel Oxide	0.1

Non-Metals	
Asbestos	0.95
Asphalt	0.95
Basalt	0.7
Carbon Non-oxide Graphite Carborundum	0.8-0.9 0.7-0.8 0.9
Ceramic	0.95
Clay	0.95
Concrete	0.95
Cloth	0.9
Glass convex glass smooth glass Nonex	0.76-0.8 0.92-0.94 0.78-0.82
Sheet material	0.96
Gypsum	0.8-0.95
Ice	0.98
Limestone	0.98
Paper	0.95
Plastic	0.95
Water	0.93
Soil	0.9-0.98
Wood	0.9-0.95

Maintenance

Cleaning

Blow away the fallen particles with clean compressed air, and carefully wipe the lens surface with a moist swab. and dean the shell with a moist sponge or soft cloth. Be careful not to rinse with water or immerse it in water.

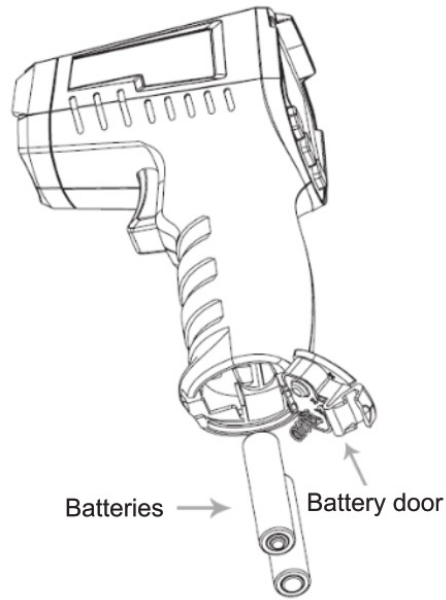

Replace Batteries

Install or replace two 1.5V batteries according to the following steps:

1. Remove the battery door
2. Install the batteries (pay attention to the polarity)
3. Close the battery door

Troubleshooting

Phenomenon	Cause	Measure
Display OL	Measured value > maximum range	Stop measuring
Display -OL	Measured value < minimum range	Stop measuring
Display Err (startup)	Exceed the minimum or maximum operating temperature	Place the thermometer at 0°C-50°C (32F -122°F) for 30 minutes
Battery symbol flashes	Low battery	Replace batteries
Laser is not working or dark	Low battery	Replace batteries
Inaccurate measurement	Unmatched emissivity, too far measurement distance, diameter of the measurement target < 20mm	Refer to Field of View, D:S and other instructions in this manual

UNI-T
UNI-TREND TECHNOLOGY (CHINA) CO., LTD.
 No.6, Gong Ye Bei 1st Road,
 Songshan Lake National High-Tech Industrial Development Zone,
 Dongguan City, Guangdong Province, China

Documents / Resources

	UNI-T UT306S Infrared Thermometer [pdf] User Manual UT306S Infrared Thermometer, UT306S, Infrared Thermometer
---	--

