

WT-DMX-S Wi-Fi and RF 5 in 1 DMX512 Master User Guide

[Home](#) » [Support](#) » [WT-DMX-S Wi-Fi and RF 5 in 1 DMX512 Master User Guide](#) 

WT-DMX-S Wi-Fi and RF 5 in 1 DMX512 Master

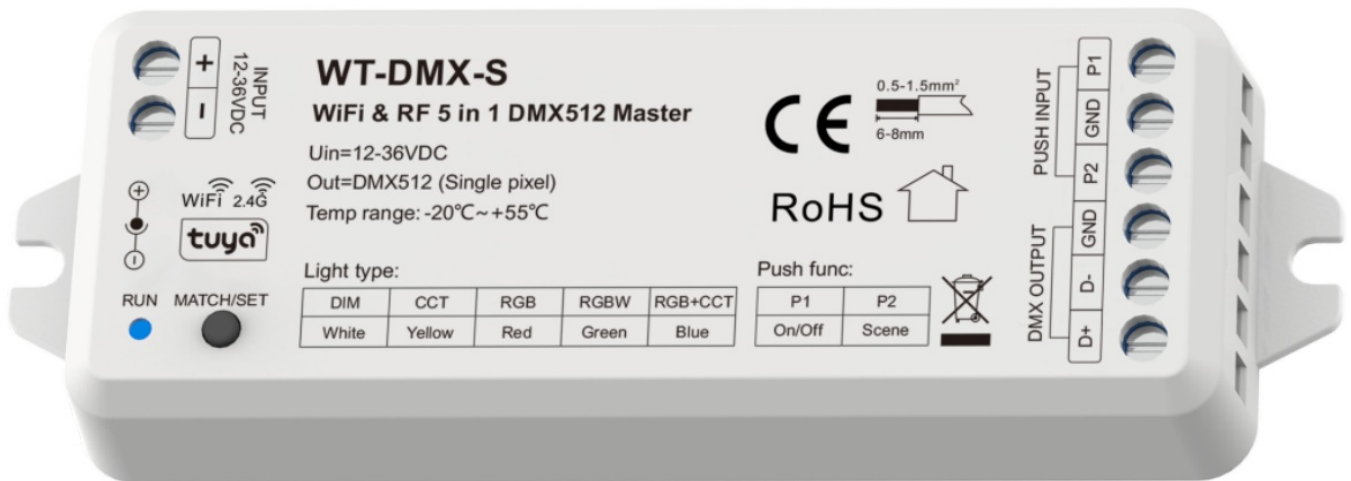

Contents

- 1 WT-DMX-S
- 2 Technical Parameters
- 3 Mechanical Structures and Installations
- 4 System wiring
- 5 Wiring diagram
- 6 DMX channel address assignment
- 7 Tuya APP network connection
- 8 Tuya APP interface
- 9 Push switch function
- 10 WT-DMX-S match RF remote control (Optional)
- 11 Default dynamic change mode (RF remote control call-out)
- 12 Documents / Resources
 - 12.1 References
- 13 Related Posts

WT-DMX-S

WiFi & RF 5 in 1 DMX512 Master

- 1-5 color WiFi-DMX master, output 1-5 channel DMX signal, comply with the DMX512 standard protocols. 8-bit (256 levels) / 16-bit (65536 levels) grey level selectable.
- Tuya APP cloud control, support on/off, RGB color, color temperature and brightness adjust, delay turn on/off light, timer run, static or dynamic scene edit and recall, music play function.
- Voice control, support Amazon Alexa, Google Assistant, Tmall Genie, Xiaodu voice assistant.
- Connect with external two push switch to achieve on/off, brightness adjustment, scene switching.
- Match with RF 2.4G remote optional.
- User need set light type by press set key before Tuya APP network connection and match RF remote of the same light type.
- Each WT-DMX-S controller can work as WiFi/RF-DMX512 converter, then use Tuya APP to control one or more DMX512 decoders for synchronized control over long distances.

Technical Parameters

Input and Output

Input voltage	12-36VDC
Input current	0.1A
Output signal	DMX512(1-5 Channel)

Warranty

Warranty	5 years
Protection	Reverse polarity

Dimming data Safety and EMC

Input signal	WiFi+ RF 2.4G + Push switch
Control distance	30m(Barrier-free space)
Dimming gray scale	256 or 65536 leve
Dimming range	0-100%

Package

Size	L120 x W43 x H27mm
Gross weight	0.055kg

Dimming data Safety and EMC

EMC standard (EMC)	ETSI EN 301 489-1 V2.2.3 ETSI EN 301 489-17 V3.2.4
Radio Equipment (RED)	ETSI EN 300 328 V2.2.2
Certification	CE, EMC, RED

Environment

Operation temperature	Ta: -20 O C ~ +55O C
Case temperature (Max.)	Tc: +65 O C

Mechanical Structures and Installations

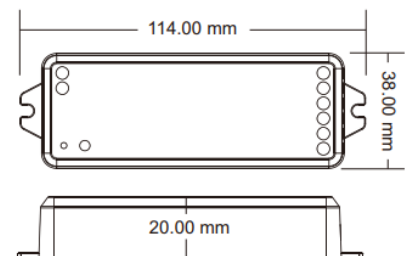
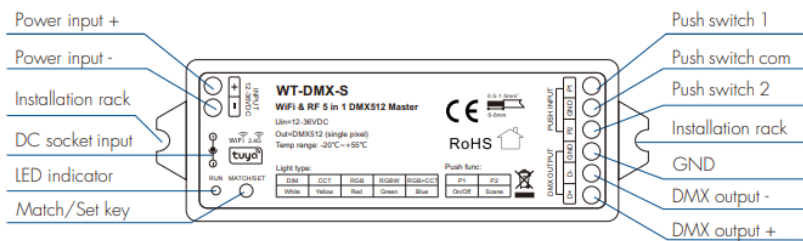

System wiring

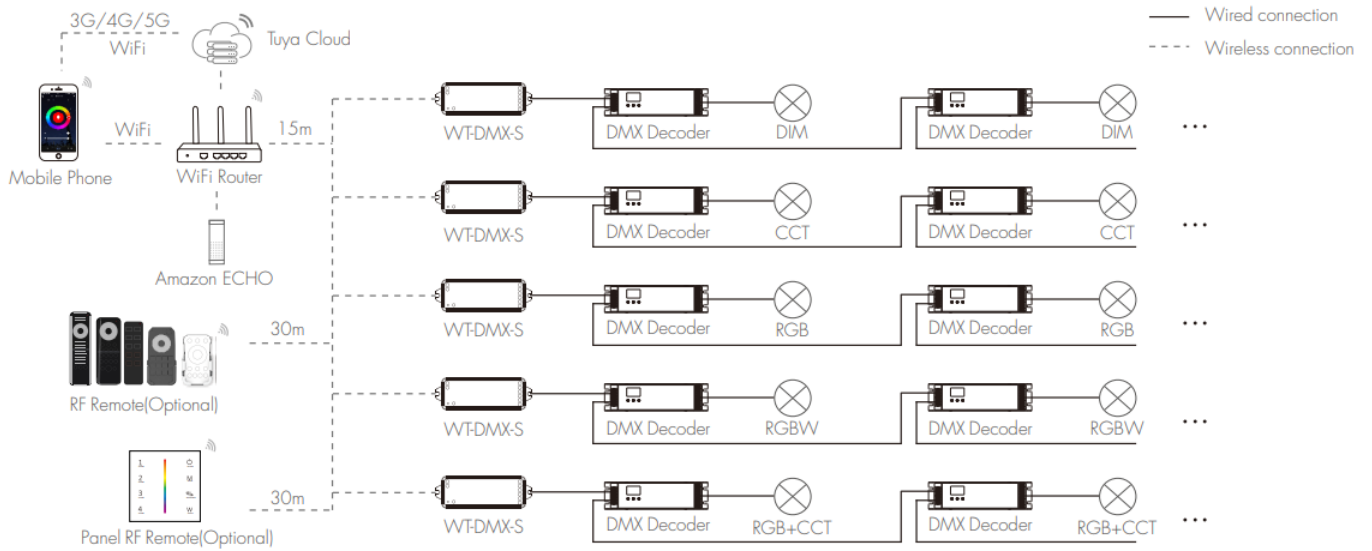

Note:

1. The above distance is measured in spacious(no obstacle) environment, Please refer to the actual test distance before installation.
2. Please check if the WiFi router net in 2.4G band, the 5G band is not available, and do not hide your router network.
3. Please keep the distance between WT-DMX-S devices and router close, and check the WiFi signals.

Wiring diagram

Take connecting multiple four-channel constant voltage DMX512 decoders to synchronously control multiple RGBW light strips as an example:

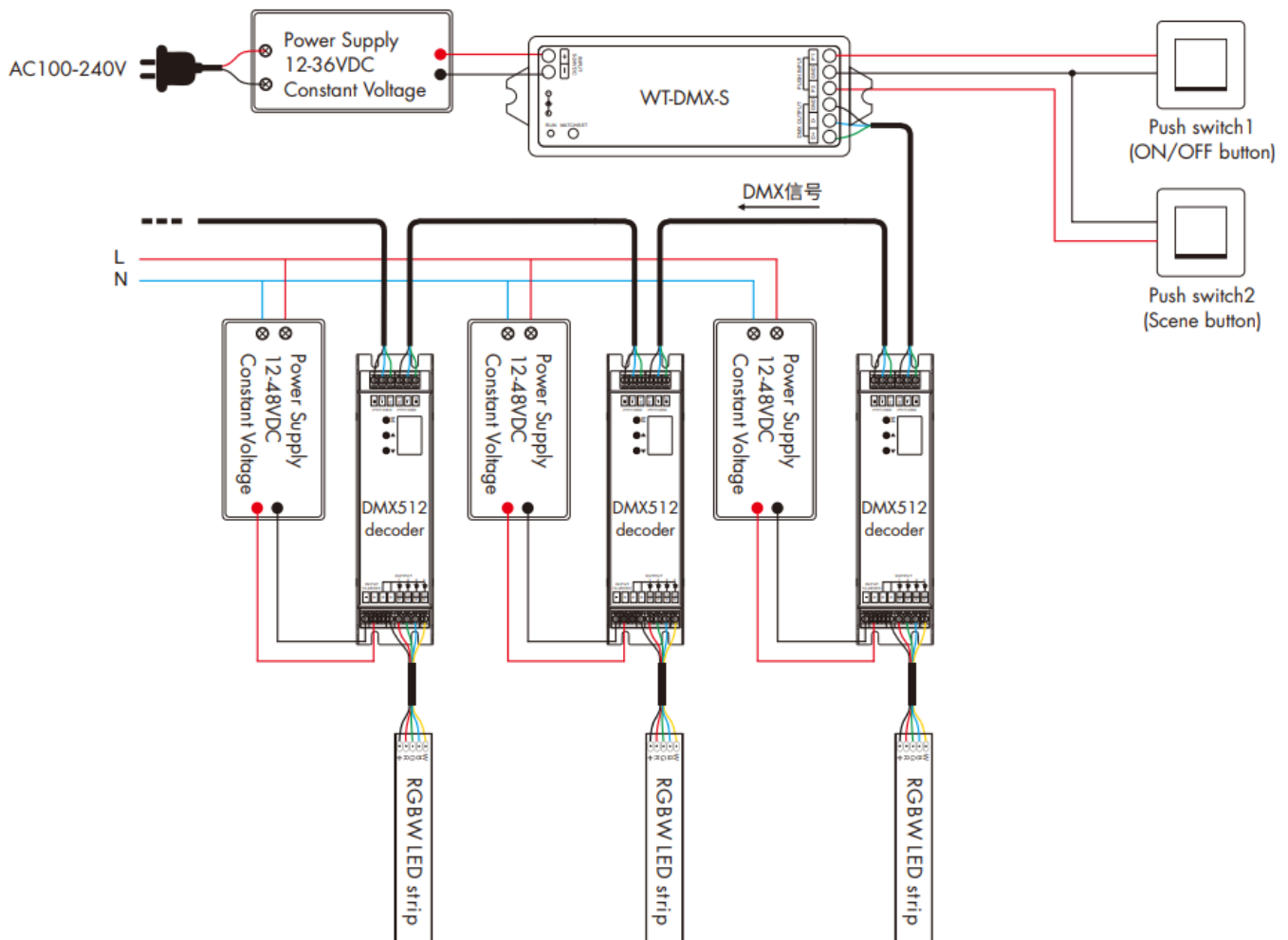

Note

- DMX512 master and DMX512 decoder need to be powered by a separate power supply.
- Light type setting: Long press the Match/Set key for 2s to sequentially switch five light types: DIM, CCT, RGB, RGBW, RGB+CCT.
 RUN indicator color (white: DIM, yellow: CCT, red: RGB, green: RGBW, blue: RGB+CCT). When the RUN indicator to change to the color that corresponds to the light type, release, then do smart config by tuya APP, or short press Match/Set key to match with RF remote.
- Factory default: RGBW light type, 8-bit grey output.
 Long press Match/Set key for 15s to restore the factory default parameter settings. Long press Match/Set key for 20s to set to 16-bit grey output. running a slow dynamic gradient effect, the recommended setting is 16-bit grey output. When setting to 16-bit grey output, note that the DMX512 decoder should be set to 16-bit decoding mode.
- An DMX signal amplifier is needed if more than 32 DMX512 decoders are connected, or use overlong signal line, signal amplification should not be more than 5 times continuously.
- If the recoil effect occurs because of longer signal line or bad line quality, please try to connect 0.25W 90-120Ω terminal resistor at the end of each DMX signal line.

DMX channel address assignment

For different light type, the correspondence of each channel address of the DMX master is as follows:

8-bit grey output:

Light type	DIM	CCT	RGB	RGBW	RGB+CCT
		WW CW	R G B	R G B W	R G B WW CW
DMX master address of each channel	1	1 2	1 2 3	1 2 3 4	1 2 3 4 5

16-bit grey output:

Light type	DIM	CCT	RGB	RGBW	RGB+CCT
		WW CW	R G B	R G B W	R G B WW CW
DMX master address of each channel	1-2	1-2 3-4	1-2 3-4 5-6	1-2 3-4 5- 6 7-8	1-2 3-4 5-6 7-8 9-10

Note: even channel for micro dimming.

Tuya APP network connection



Smart life APP



Tuya Smart

Please download the corresponding tuya/smart life app according to your region.

Press and hold Match/Set key for 2s, switch 5 kinds light type in sequence, notice this operation does not automatically clear previous network connection.

Press and hold Match/Set key for 5s, or push twice Match/Set key fastly, clear previous network connection, enter Smart config mode, the purple LED indicator flash fastly.

Repeat power on and off for 5 consecutive times, also clear previous network connection, enter Smart config mode.

In Tuya APP, automatically add devices, you can find RGBW device (or other DIM, CCT, RGB or RGB+CCT). If Tuya APP network connection succeed, the RUN LED indicator will stop flash purple, and turn corresponding light type color (White: DIM, Yellow: CCT, Red: RGB, Green: RGBW, Blue: RGB+CCT).

Tuya APP interface

White interface

For DIM type:

Touch brightness slide to adjust brightness.

For RGB type:

Touch brightness slide, get RGB mixed white firstly, then to adjust white brightness.

For RGBW type:

Touch brightness slide, adjust white channel brightness.

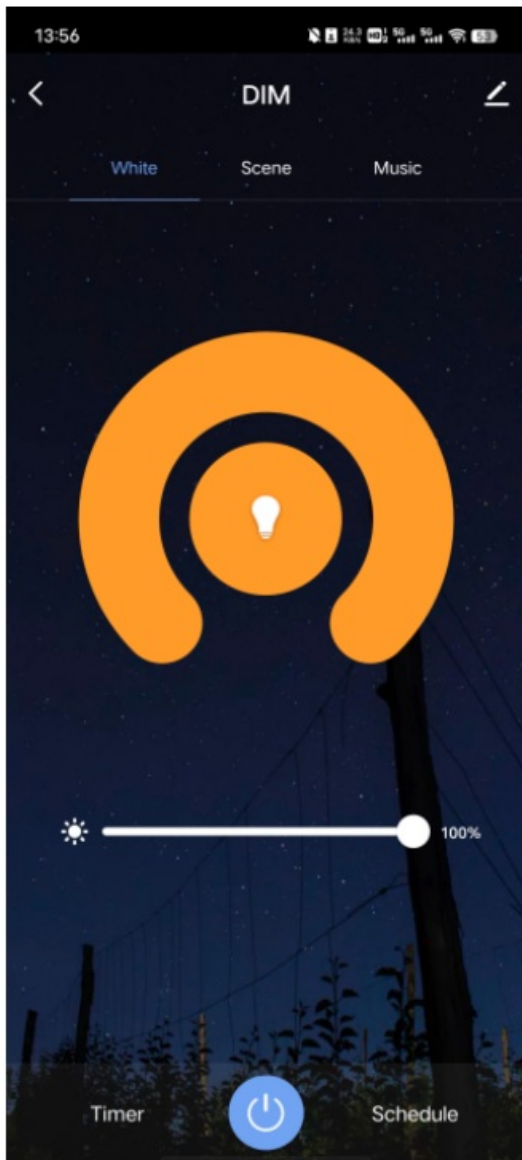

Colour interface

For RGB or RGBW type:

Touch color wheel to adjust static RGB color.

Touch brightness slide to adjust color brightness.

Touch saturation slide to adjust color saturation, namely gradient from the current color to white (RGB mixed).

For RGB+CCT type:

Touch color wheel to adjust static RGB color, WW/CW will turn off automatically.

Touch brightness slide to adjust color brightness.

Touch saturation slide to adjust color saturation, namely gradient from the current color to white (RGB mixed)

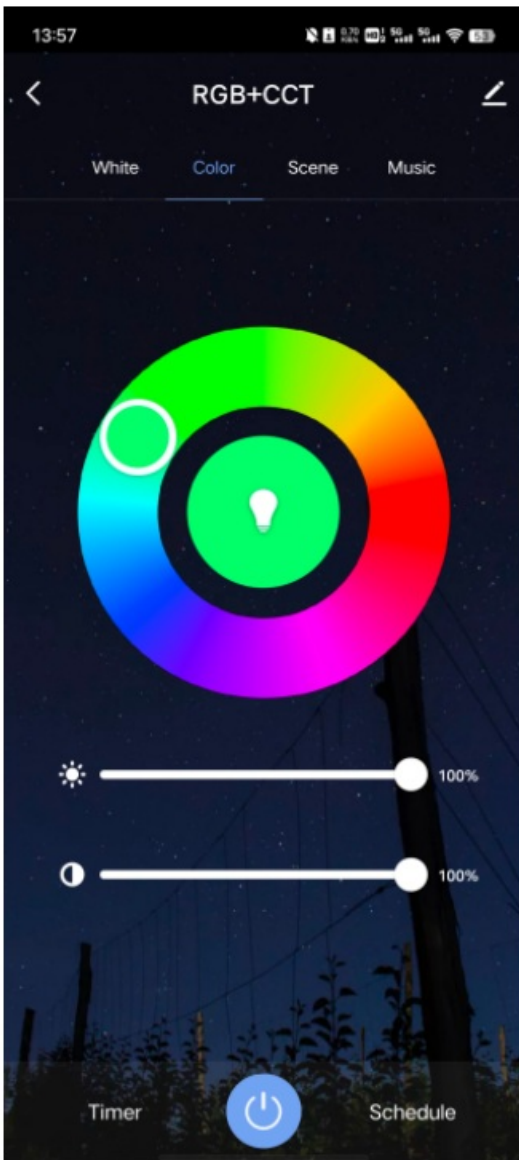

Color temperature interface

For CCT type:

Touch color wheel to adjust color temperature.

Touch brightness slide to adjust brightness.

For RGB+CCT type:

Touch color wheel to adjust color temperature, RGB will turn off automatically.

Touch brightness slide to adjust white brightness.

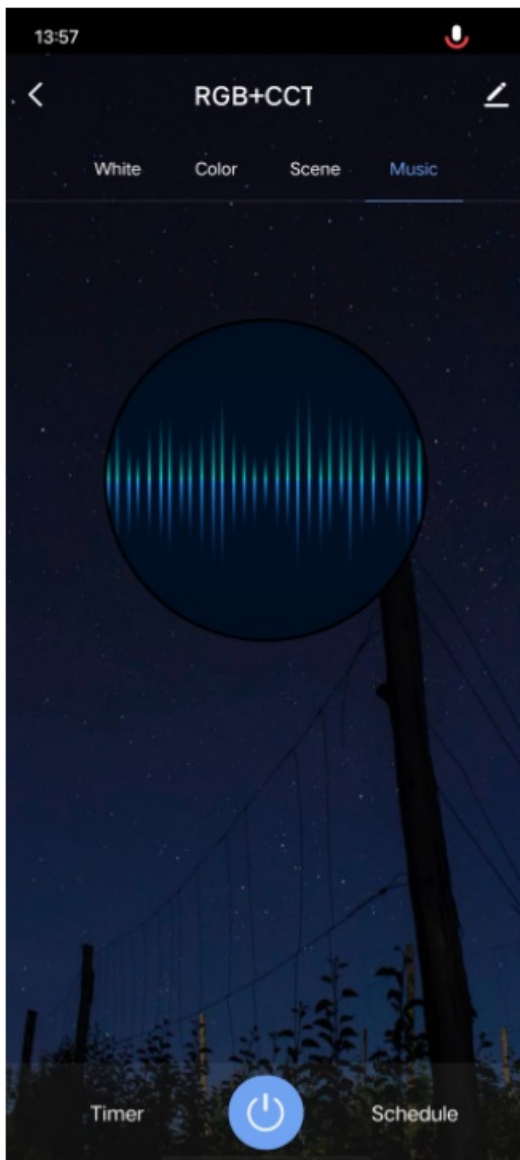

Scene interface

The 1-4 scene is static color for all light type. the inner color of these scene can be editable.

The 5-8 scene is dynamic mode for RGB, RGBW, RGB+CCT type, such as green fade in and fade out, RGB jump, 6 color jump, 6 color smooth.

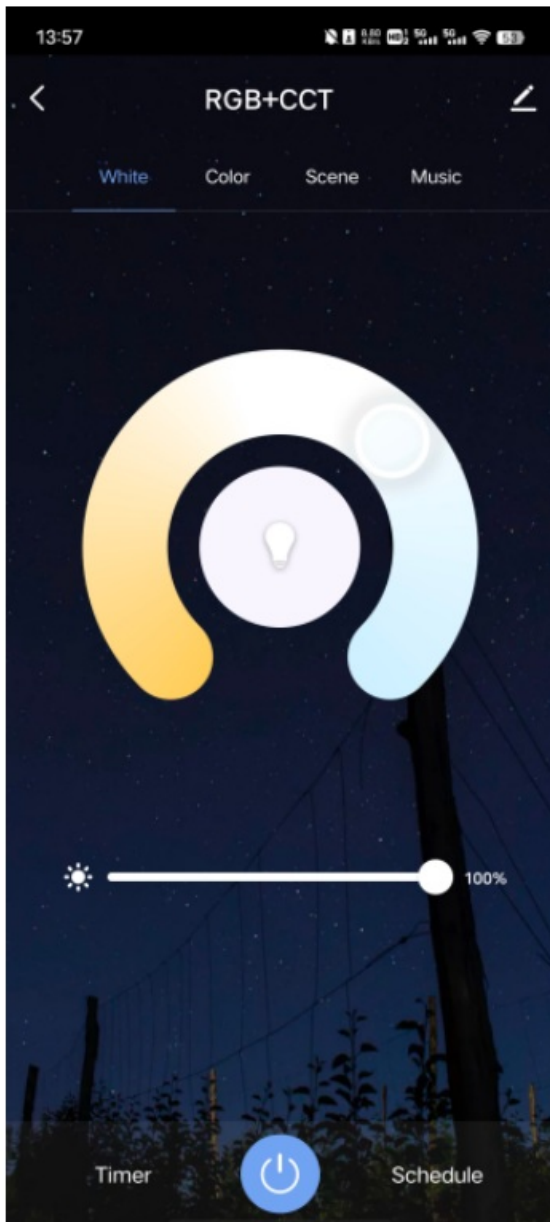

Music, Timer, Schedule

The music play can use smart phone music player or micro-phone as music signal input.

The Timer key can turn on or turn off light in the next 24 hours.

The Schedule key can add multiple timers to turn on or turn off light according to different time periods.

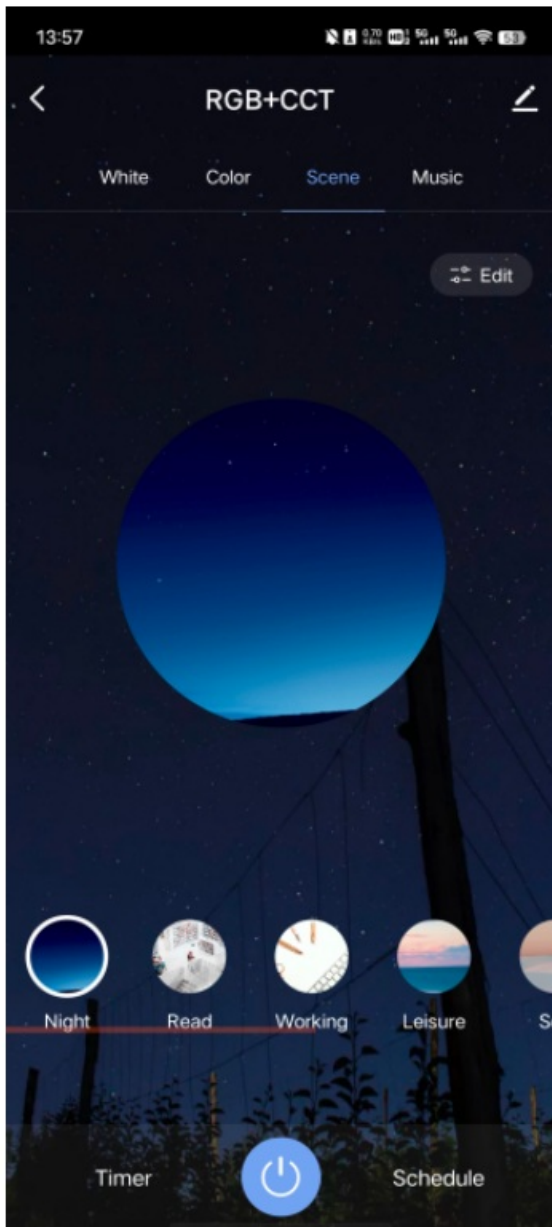

Push switch function

Push switch 1 (ON/OFF button) Short press: Turn on/off the light.

Long press(1-6s): Step-less dimming, with every other long press, the light level goes to the opposite direction.

Push switch 2 (Scene button)

Short press: For DIM/CCT light type, sequential switching of the 4 scenes. For RGB/RGBW/RGB+CCT light type, sequential switching of the 8 scenes.

Long press(>2s): Recall scene 1. Users can set static or dynamic scenes via Tuya Smart/Smart Life APP

WT-DMX-S match RF remote control (Optional)

End user can choose the suitable match/delete ways. Two options are offered for selection:

Use the WT-DMX-S's Match/Set key

Match:

Short press match/set key of WT-DMX-S, immediately press on/off key (single zone remote) or zone key (multiple zone remote) on the remote.

The LED indicator fast flash a few times means match is successful.

Delete:

Press and hold match/set key of WT-DMX-S for 10s, The LED indicator fast flash a few times means all matched remotes were deleted.

Use Power Restart

Match:

Switch off the power of WT-DMX-S, then switch on power, repeat again.
Immediately short press on/off key (single zone remote) or zone key (multiple zone remote) 3 times on the remote.
The light blinks 3 times means match is successful.

Delete:

Switch off the power of WT-DMX-S, then switch on power, repeat again.
Immediately short press on/off key (single zone remote) or zone key (multiple zone remote) 5 times on the remote.
The light blinks 5 times means all matched remotes were deleted.

Default dynamic change mode (RF remote control call-out)

For RGB/RGBW:

No.	Name	No.	Name
1	RGB jump	6	RGB fade in and out
2	RGB smooth	7	Red fade in and out
3	6 color jump	8	Green fade in and out
4	6 color smooth	9	Blue fade in and out
5	Yellow cyan purple smooth	10	White fade in and out

For RGB+CCT:

No.	Name	No.	Name
1	RGB jump	6	RGB fade in and out
2	RGB smooth	7	Red fade in and out
3	6 color jump	8	Green fade in and out
4	6 color smooth	9	Blue fade in and out
5	Color temperature smooth	10	White fade in and out

CE RoHS  RED

Documents / Resources

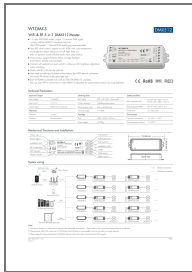

[WT WT-DMX-S Wi-Fi and RF 5 in 1 DMX512 Master](#) [pdf] User Guide
WT-DMX-S Wi-Fi and RF 5 in 1 DMX512 Master, WT-DMX-S, Wi-Fi and RF 5 in 1 DMX512 Master, RF 5 in 1 DMX512 Master, 5 in 1 DMX512 Master, DMX512 Master, Master

References

- [User Manual](#)

[Manuals+](#), [Privacy Policy](#)

This website is an independent publication and is neither affiliated with nor endorsed by any of the trademark owners. The "Bluetooth®" word mark and logos are registered trademarks owned by Bluetooth SIG, Inc. The "Wi-Fi®" word mark and logos are registered trademarks owned by the Wi-Fi Alliance. Any use of these marks on this website does not imply any affiliation with or endorsement.