

Tenda TES70 Series GPON OLT Receiver



Tenda TES70 Series GPON OLT Receiver Installation Guide

[Home](#) » [Tenda](#) » Tenda TES70 Series GPON OLT Receiver Installation Guide 

Contents

- [1 Tenda TES70 Series GPON OLT Receiver](#)
- [2 Preface](#)
- [3 OLT front panel ports description](#)
- [4 Documents / Resources](#)
 - [4.1 References](#)

Tenda

Tenda TES70 Series GPON OLT Receiver



Copyright Statement

2022 Shenzhen Tenda Technology Co., Ltd. All rights reserved. is a registered trademark legally held by Shenzhen Tenda Technology Co., Ltd. Other brand and product names mentioned herein are trademarks or registered trademarks of their respective holders. Copyright of the whole product as integration, including its accessories and software belongs to Shenzhen Tenda Technology Co., Ltd. No part of this publication can be reproduced, transmitted, transcribed, stored in a retrieval system, or translated into any language in any form or by any means without the prior written permission of Shenzhen Tenda Technology Co., Ltd.

Disclaimer

Pictures, images and product specifications herein are for reference only. To improve internal design, operational function, and/or reliability, Tenda reserves the right to make changes to the products without obligation to notify any person or organization of such revisions or changes. Tenda does not assume any liability that may occur due to the use or application of the product described herein. Every effort has been made in the preparation of this document to ensure the accuracy of the contents, but all statements, information and recommendations in this document do not constitute a warranty of any kind, express or implied.

Preface

Thank you for choosing Tenda! This guide walks you through the pre-installation preparation and hardware installation on the TES70 series GPON OLT. All the figures herein are only for illustration. Refer to the actual conditions.

Application scope

The application scope of this guide is listed below.

Audience	Product	Product hardware version
Internal staff		
FTTX O&M (operation and maintenance) engineer	Tenda GPON OLT TES7004, TES7008, TES7016	All hardware versions of Tenda GPON OLT
Customer technical engineer		

Conventions

The symbol that may be found in this document is defined as follows.

Symbol	Meaning
	This format is used to supplement or explain relevant operations.

For more documents

Search target product models on our official website www.tendacn.com to obtain the latest product documents. The related documents are listed below.

Document	Description
Quick Start Guide	It introduces the login and service configurations of the OLT device.
Quick Installation Guide	It introduces how to install the OLT device quickly, including pre-installation preparation, hardware installation, OLT default configuration, and so on.
User Manual	It introduces the basic information of the OLT device, including product features, hardware structure, network application, system management, and so on.
User Guide for Web Management	It introduces how to set up more functions of the OLT device for more requirements, including all functions on the web UI.
User Guide for EMS Management	It introduces how to set up functions on the EMS network management system of the OLT device.
Tenda Lightning Protection Guide	It introduces device lightning protection, including lightning protection terminology and basic knowledge, lightning protection guide of devices, lightning arrester installation.

Technical support

Contact us if you need more help. We will be glad to assist you as soon as possible.

Email address: support@tenda.cn

Website: www.tendacn.com

Revision history

Tenda is constantly searching for ways to improve its products and documentation. The following table indicates any changes that might have been made since the guide was released.

Version	Date	Description
V1.0	2022-12-02	Original publication

Device appearance

TES7004/TES7008/TES7016 are 1U standard Pizza Box devices and can be mounted into a standard 19-inch rack. The length, width, and height of the device is 440 mm * 240 mm * 44 mm.

Front panel

TES7004 front panel appearance



TES7008 front panel appearance



TES7016 front panel appearance



OLT front panel ports description

Device		TES7004	TES7008	TES7016
Model	Port Type			
Uplink port	SFP Port	2 * 10-gigabit ports	Optional: - 2 * 10-gigabit ports - 2 * 10-gigabit ports + 2 * gigabit ports	2 * 10-gigabit ports + 2 * gigabit ports
	RJ-45 Ethernet Port	2 * gigabit ports	Optional: - 2 * gigabit ports - 4 * gigabit ports	2 * gigabit ports
GPON port		4 * SFP ports	8 * SFP ports	16 * SFP ports
Console port		1 port that meets RS232 technical specifications		
Type-C port		1 port that meets USB Type-C/ RS232 technical specifications		
Outband management port		1 port that meets 10/100/1000 Base-TX technical specifications		

OLT front panel button description

RST: Reset button. Press and hold this button with a needle-like object for about 2 seconds, and then release it, the OLT will restart. After about 2 minutes, the device will complete restarting.

LED status description

Unless other specified, the corresponding descriptions apply to all TES70 series products

LED Indicator Type	Status	Description
ACT (System status indicator)	Solid green	System running properly
	Slowly blinking green	System initializing, or software starting but master-slave communication state is not established
	Fast blinking green	System receiving configuration commands, or establishing master-slave communication state
	Off	System powered off or software not started
ALM (Alarm indicator)	Solid red	System alarms occurred
	Off	No system alarms
NMS (Management port indicator)	Yellow	Indicates that port rate is 100 M. Blinking indicates that management port is transmitting or receiving data.
	Green	Indicates that port rate is 1000 M. Blinking indicates that management port is transmitting or receiving data.
	Off	Management port disconnected or connect improperly
PWR1/PWR2 (Power supply indicator)	Solid green	Normal power input/output
	Off	No power supply or abnormal power input/output
TES7004 PON 1-4 TES7008 PON1-8 TES7016 PON1-16 (PON port indicator)	Solid on	ONT connected to the PON port
	Off	No ONT connected to the PON port

LED Indicator Type	Status	Description
TES7004 UPLINK XGE1/XGE2	Solid on	Port connected
TES7008 UPLINK XGE1/XGE2	Fast blinking	Port transmitting or receiving data
TES7016 UPLINK XGE1/XGE2, GE3/GE4 (Uplink port indicator)	Off	Port disconnected or connect improperly
TES7004 UPLINK GE3/GE4	Yellow	Indicates that port rate is 100 M.
TES7008 UPLINK GE3/GE4		Blinking indicates that management port is transmitting or receiving data.
TES7016 UPLINK GE5/GE6	Green	Indicates that port rate is 1000 M.
(Ethernet port indicator)		Blinking indicates that management port is transmitting or receiving data.
	Off	Management port disconnected or connect improperly

Back panel

TES7004/7008/7016 back panel appearance (dual AC as an example)



Rear panel description

Type	Description
GND	1 grounding terminal on the left side of the rear panel for the grounding of the device shell
Power	Power port of the device. You can select the power supply type (AC or DC) and the number of power ports (one or two) as required.

Hardware installation

Open the box and checkout

Check the products referring to the package contents or contract. If any item is missing, or damaged, please keep the original package and contact the local reseller or distributor immediately.

The package contents include the following items:

- OLT device * 1
- AC power cord or DC power accessories (The quantity is based on the power supply specifications you choose.)
- L-shaped bracket * 2
- Screw * 8
- Footpad * 4

Installation requirements

Power requirements

The input voltage must be stable with neither EMI noise nor distortion.

- When a DC power supply is used, the input voltage is – 48 V DC and the allowed range is 40 V DC to – 72 V DC.
- When an AC power supply is used, the input voltage is 110/220 V AC and the allowed range is 100 V DC to 240 V AC.
- All safety requirements and rules about electricity in the locality or the building must be followed. All power supplies must be legal.

Device grounding requirements

A good grounding system is the basis for the stable and reliable operation of the device, and an important guarantee for lightning, anti-interference and anti-static protection of the device. Users must provide a good grounding system for the device.

Installation Site Requirements

To ensure the stable operation of the device in the long run, the installation site must meet the following requirements:

- The working environment temperature of the device should be controlled at -5°C to 45°C. Place the device away from the main heat source (such as the power supply). If the ambient temperature is higher than 45 °C, improve the ventilation of the room, such as installing fans or air conditioners.
- The humidity of the installation site should range from 10% to 95%, non-condensing and frost-free.

Installations preparations

Safety precautions

- Check the following working environment and installation requirements:
- During installation, wear ESD wrist straps or gloves. And the OLT should be powered off.
- Please use the included power adapter/power cord.
- Ensure that the input voltage is within the input range indicated on the OLT.
- The device should be installed in a dry, cool place and at least have a 10 cm space away from its surroundings on both sides for ventilation.
- The device should be located far away from the heat source or other sources of strong electromagnetic interference (such as power lines, lights, and power grids).
- Keep the air in the operating environment clean. Remove dust from the OLT regularly.
- Disconnect the power supply before cleaning the OLT. Do not clean the OLT with any liquid.
- Do not open the chassis of the OLT.

- Do not place heavy objects on the OLT.

Preparations before installations

- Ensure that the related cables (such as optical fibres, Ethernet cables, and grounding cables) are properly routed.
- Ensure that the cable and connectors used for installation are normal.
- If the OLT adopts the rack mounting method, ensure that you have prepared the necessary mounting screws, nuts and tools (such as ladders, screwdrivers).
- If the OLT adopts DC power supply mode, prepare cables for connecting the -48 V DC power supply to the -48 V DC power input port of the OLT device (two cables for connecting the positive and negative terminals of the power supply respectively).
- Prepare the following items to connect to the OLT for network connectivity and network management checks:
 - A management platform, such as a computer
 - RJ45/DB9 RS232 Console line
 - Universal USB Type-C cable (for Console management)

OLT installation

Rack mounting (19 inch)

Step 1 Ensure that the rack is stable, level and properly grounded.

Step 2 Fix the L-shaped brackets to both sides of the OLT with the included screws.

Step 3 Place the OLT in an appropriate position in the rack. Fix the L-shaped brackets to the rack with screws (self-prepared). Ensure that the OLT is stable on the rack.

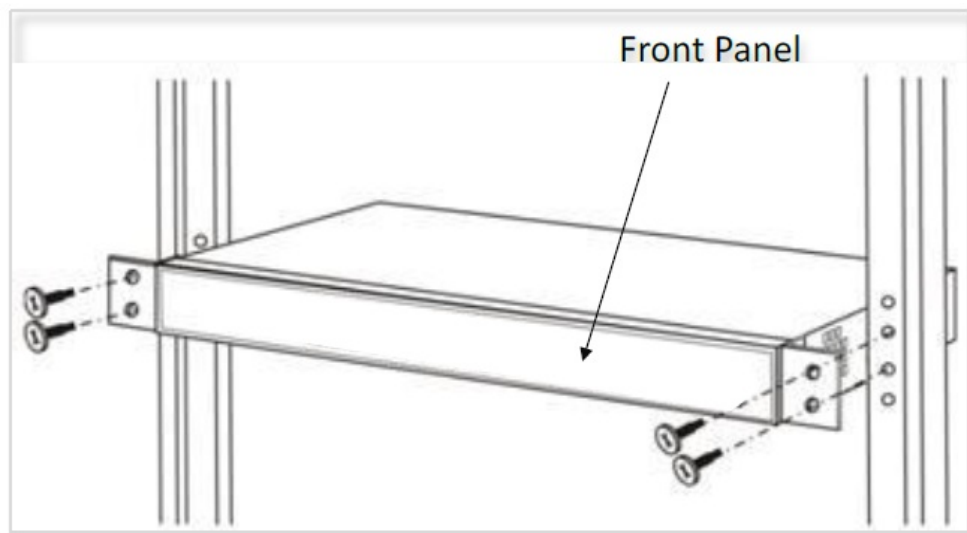

Cables connecting

The chapter describes the port, power supply and grounding connection of the OLT device. Read the instructions carefully before connecting the OLT.

Uplink port connecting

OLT provides uplink RJ-45 Ethernet ports and uplink SFP ports. For the specific port quantities and specifications of each model of OLT device, refer to the OLT front panel ports description in 1.1 Front panel.

- If RJ-45 Ethernet ports of the OLT are used to connect uplink devices, the requirements are as follows:
 - Connection cable: Category 5 (CAT5) or above Ethernet cable (crossover or straight-through cable)
 - Cable connector: RJ45 connec

If SFP ports of the OLT are used to connect uplink devices, the requirements are as follows:

- Connection cable: Optical fibre (single-mode or multi-mode)
- Cable connector: LC connector
- Optical module: SFP optical module, SFP+ optical module
- The optical module is not provided with the OLT. Please prepare the SFP and SFP+ optical modules yourself.
- The standards of SFP optical modules complied with 1000 Base-LX, 1000 Base-SX, 10/100/1000 Base-TX.
- The standards of SFP+ optical modules complied with 10 G Base-LR/LW, 10 G Base-ER/EW, and 10 G Base-SR.
- When the single-mode optical fibre is used, the maximum transmission distance can be up to 10 to 80 km.
- When the multimode fibre is used, the maximum transmission distance is less than 500 m.

PON port connecting

OLT supports GPON SFP slots. Each SFP GPON slot can be mounted with a GPON SFP module and provide one PON port.

The GPON SFP slot supports the following optical module standards:

- ITU-T G.984.2 Class B+
- ITU-T G.984.2 Class C+
- ITU-T G.984.2 Class C++
- The OLT SFP interface is SC/PC. Please use the patch cord with the SC/PC connector to connect the OLT and the ODN networking.

Grounding cable connecting

To ensure the safety and reliable working of OLT, proper ground connection should be performed for OLT. For detailed grounding methods, refer to the Tenda Lightning Protection Guide.

Power supply connecting

Connect the power supply of the OLT based on your power supply selection and the corresponding power supply connection instructions.

Using AC power supply

You can select a dual AC version OLT device. The dual AC version OLT device supports dual power supply 1 + 1 redundancy. If one power supply unit fails, the system will continue operation using the other power supply unit. To ensure true AC line input redundancy for the OLT, connect each AC power cable to a different AC power source.

The procedure for connecting the AC power supply is as follows:

Step 1 Get the supplied AC power cords from the OLT's package contents.

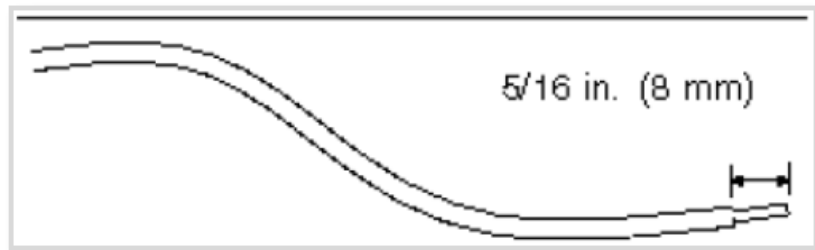

Step 2 Connect one end of each AC power cord to the AC power inlet connectors located at the rear of the OLT.

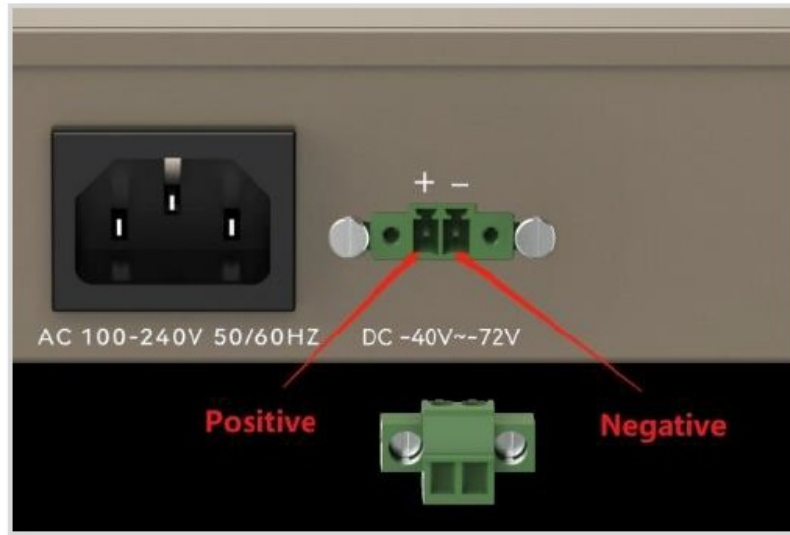

Step 3 Connect the other ends of the power cords to AC wall outlets.

Using a DC power supply

Step 1 Prepare two cables for connecting the -48 V DC power supply to the -48 V DC power input port on the OLT device yourself (for connecting the positive and negative terminals of the power supply respectively).

Step 2 Turn off the -48 V DC power supply.

Step 3 Get a DC input plug from the package contents.

Step 4 Connect the DC power supply to the device with the two cables prepared in Step 1:

- 48 V: negative terminal: NEG(-)
- 48 V: positive terminal: RTN(+)

The detailed procedures are as follows:

1. Strip 8 mm (5/16 inches) of insulation from each cable.
2. Fit the exposed section of the copper wire into the rectangular plug hole in the DC input plug, and tighten the screw to fix the copper wire.
3. Insert the DC plug of the connected cable into the DC connection socket of the OLT device.

Power supply checkout

Before you connect the power supply, carefully check the power supply to see whether it is in line with the power supply requirements and whether the device is in reliable grounding. After verification, you can turn on the power supply sources.

OLT working status checkout

Please check the OLT's working status from the following aspects:

- Check the PWR (power indicator). The indicator should be solid green.
- Check the ACT (system status indicator). The indicator should be solid green.
- If the uplink device is connected to the uplink port, the target connection indicator is on.

ONT registration status checkout

By default, after the ONT device is started, it will be registered on the OLT without any configuration. You can prepare an ONT device for registration checkout. Before connecting the device, it is recommended to use an optical power meter to test whether the optical function is within the working range required by the device. Then, connect the ONT device to the PON port of the OLT. The corresponding PON port indicator should be on, and the ONT is registered successfully.

Network connection checkout

By default, after the ONT device is normally registered on the OLT, the network between the ONT user and the device connected to the OLT should be connected.

The checkout procedures are as follows

Step 1 Connect a test computer to the user port of the ONT device.

Step 2 Use the PING package tool on the test computer to ping the IP address of the OLT uplink devices in the same LAN (same IP address segment).

Checkout result: The IP address of the OLT uplink devices can be pinged successfully on the test computer.

Network management checkout

The management computer can manage the device in the following two ways.

Local command line interface management

Use a DB9 or Type-C serial cable to connect the management computer to the Console management port of the OLT device, and then access the command line management interface of the OLT device through the serial port. For related parameters, refer to OLT default configuration.

Web management

Use an Ethernet cable to connect the management computer to the NMS outbound management port of the OLT device, and then access the web UI of the OLT device on a browser. For related parameters, refer to OLT default configuration.

OLT default configuration

Network parameter configuration

The default IP address of the OLT outbound management port:

- IP Address: 192.168.0.254
- Subnet Mask: 255.255.255.0

OLT console parameter configuration

- Baud Rate: 115200
- Data Bit: 8
- Parity Check: NO
- Stop Bit: 1
- Flow Control: NO

OLT default username and password

Default login username and password of CLI command line:

- Username: admin
 - Password: admin
-

Documents / Resources

	<p>Tenda TES70 Series GPON OLT Receiver [pdf] Installation Guide TES70 Series GPON OLT Receiver, TES70 Series, GPON OLT Receiver, OLT Receiver, Receiver</p>
---	--

References

- [Tenda US](#)
- [Tenda US](#)
- [Tenda US](#)
- [User Manual](#)

Manuals+. Privacy Policy

This website is an independent publication and is neither affiliated with nor endorsed by any of the trademark owners. The "Bluetooth®" word mark and logos are registered trademarks owned by Bluetooth SIG, Inc. The "Wi-Fi®" word mark and logos are registered trademarks owned by the Wi-Fi Alliance. Any use of these marks on this website does not imply any affiliation with or endorsement.