



# Tenda AX1800 Wi-Fi 6 Range Extender Installation Guide

[Home](#) » [Tenda](#) » Tenda AX1800 Wi-Fi 6 Range Extender Installation Guide 

## Contents

- [1 Tenda AX1800 Wi-Fi 6 Range Extender](#)
- [2 Power on the extender](#)
- [3 Connect to the internet](#)
- [4 Configuration completed](#)
- [5 More methods](#)
- [6 Method 2: Set up the extender in AP mode](#)
- [7 Relocate the extender \(applicable for extender mode only\)](#)
- [8 Connect to the extender](#)
- [9 FAQ](#)
- [10 Appearance](#)
- [11 FCC Statement](#)
- [12 RECYCLING](#)
- [13 Technical Support](#)
- [14 Documents / Resources](#)
- [15 Related Posts](#)

The Tenda logo, featuring the word 'Tenda' in a bold, orange, italicized sans-serif font.

## Tenda AX1800 Wi-Fi 6 Range Extender



### Power on the extender

Plug the extender into a power outlet near the router, and wait until the LED indicator of the extender blinks red.

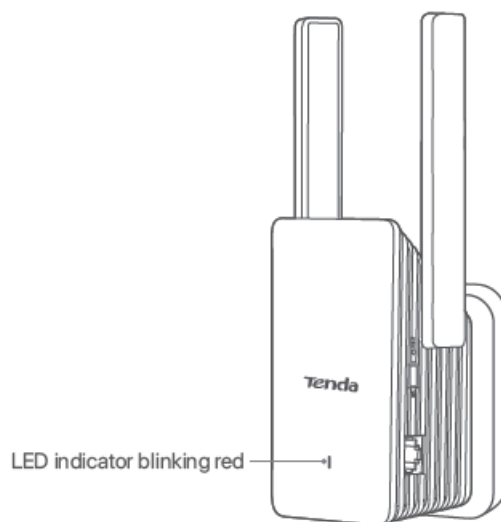

### Connect to the internet

#### Method 1: Set up the extender in extender mode

##### Setup by smartphone

1. Connect the smartphone to the WiFi network of the extender: Tenda\_EXT and when the web UI of the extender is displayed automatically, tap Start Now.

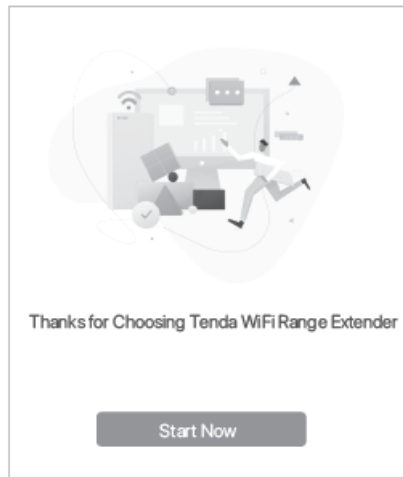

If the above page does not appear, please start a web browser, and access [re.tenda.cn](http://re.tenda.cn) in the address bar to manually log in to the web UI. If the web UI still does not appear, refer to Q1 in FAQ.

2. Set Login Password, and tap Next.

A screen titled "Set Login Password". Below the title, it says "Set Extender Login Password" and "For network security, please set a login password for logging in to the web UI." There are two input fields: "Login Password" and "Confirm Password". At the bottom, there are two buttons: "Notnow" and "Next".

3. Choose Extender Mode, tap Next.

A screen titled "Working Mode" with a back arrow on the left. It says "Please choose the working mode based on your scenario". There are two options: "Extender Mode" with a checked radio button and the description "Extend the coverage of the existing WiFi network.", and "AP Mode" with an unchecked radio button and the description "Convert the existing wired network to a WiFi network.". At the bottom, there is a dark grey button with the text "Next" in white.

4. Choose the WiFi network to be extended.

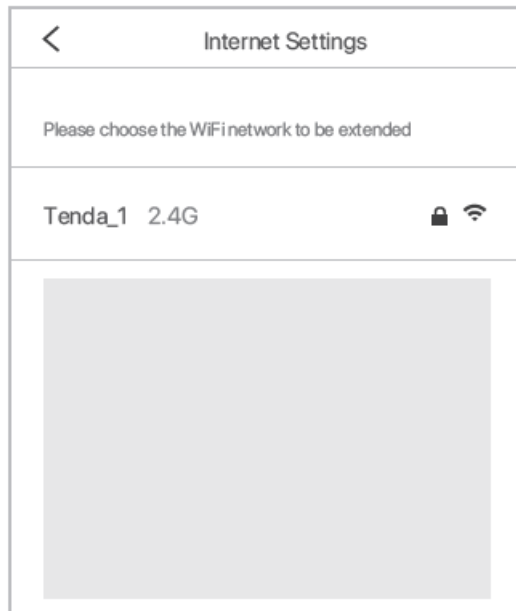

5. Enter the WiFi password of the extended network. You can change the extender WiFi name as required, and tap Next.

The screenshot shows the 'Internet Settings' screen with configuration options. At the top, there is a back arrow and the title 'Internet Settings'. Below the title, there are three sections:

- Upstream WiFi Name**: Tenda\_1
- Upstream WiFi Password**: No fewer than 8 characters
- Extender WiFi Name**: Tenda\_1

Below these sections, there is a paragraph of text: 'The WiFi name and WiFi password of the extender are those of the upstream WiFi network; you can also choose to customize the extender WiFi name'. At the bottom of the screen, there is a gray button labeled 'Next'.

6. Tap Extend.

LED indicator lighting solid on indicates successful extension. You can connect to the following WiFi network to access the internet

WiFi Name: Tenda\_1

WiFi Password: XXXXXXXX



- Solid blue: Proper position or too close to the router
- Solid yellow: Fair position. Move towards the router
- Solid red: Poor position. Move towards the router

⊗ LED indicator blinking red indicates extension failed. Please connect to the following network to extend again

WiFi Name: Tenda\_EXT



- Blinking red: Extension failed. Please connect to the WiFi network of the extender (Tenda\_EXT) and extend again

Extend

## Configuration completed

### Completed

Configuration completes. Please perform operations depending on the status of the LED indicator.

LED indicator lighting solid on indicates successful extension. You can connect to the following WiFi network to access the internet

- WiFi Name: Tenda\_1
- WiFi Password: XXXXXXXX
  - Solid blue: Proper position or too close to the router
  - Solid yellow: Fair position. Move towards the router
  - Solid red: Poor position. Move towards the router

LED indicator blinking red indicates extension failed. Please connect to the following network to extend again

### WiFi Name: Tenda\_EXT

- Blinking red: Extension failed. Please connect to the WiFi network of the extender (Tenda\_EXT) and extend again

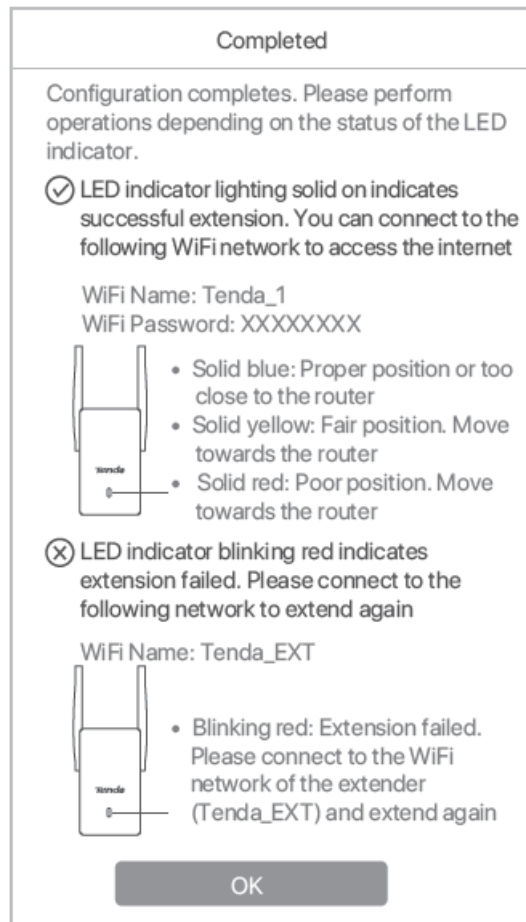

## More methods

### Setup by computer

1. Connect your laptop to the WiFi network of the extender: Tenda\_EXT, or use an Ethernet cable to connect the computer to the Ethernet port of the extender.
2. The computer is redirected to the web UI of the extender. Click Start Now.
3. Set the extender to work in Extender Mode to bridge the router WiFi network following the onscreen instructions.

If you cannot log in to the web UI, please start a web browser, and access [re.tenda.cn](http://re.tenda.cn) in the address bar to manually log in to the web UI. If the web UI still does not appear, refer to Q1 in FAQ.

### Setup by WPS button

This method is applicable for the router having a WPS button or supporting Tenda Wi-Fi+ Mesh technology.

1. Press the WPS button on the router to enable its WPS function.
2. Within 2 minutes, press the WPS button on the extender, and its LED indicator blinks red fast. When the LED indicator lights solid on, the setup is successful.

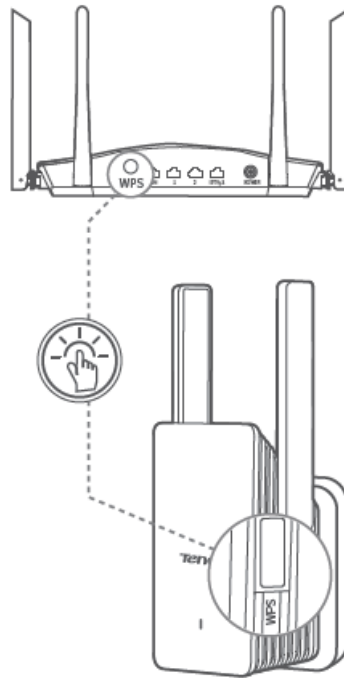

## Method 2: Set up the extender in AP mode

1. Use an Ethernet cable to connect the Ethernet port of the extender to the LAN port of the router.

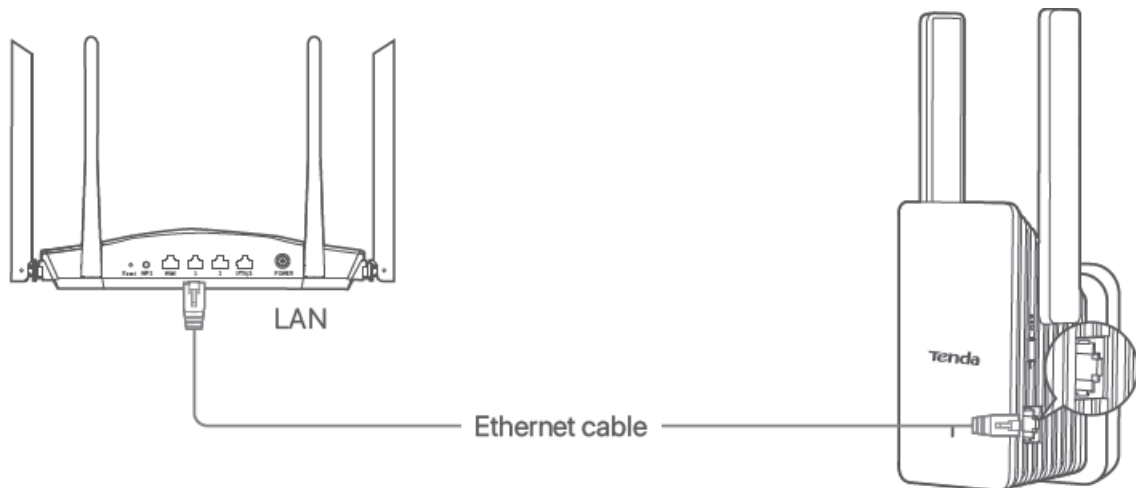

2. Connect your smartphone to the WiFi network of the extender: Tenda\_EXT.
3. The smartphone is automatically redirected to the web UI of the extender. Tap Start Now and set the extender to work in AP Mode following the onscreen instructions.

If you cannot log in to the web UI, please start a web browser, and access [re.tenda.cn](http://re.tenda.cn) in the address bar to manually log in to the web UI. If the web UI still does not appear, refer to Q1 in FAQ.

## Relocate the extender (applicable for extender mode only)

1. Refer to the following relocation tips to locate the extender to obtain a better performance.
  - Place the extender between the router and the WiFi dead zone (the location you choose must be within the coverage of the router).
  - Keep your extender away from electronics with strong interference, such as microwave ovens, induction cookers, and refrigerators.
  - Place the extender in a high position with few obstacles.

2. Observe the LED indicator of the extender to ensure the extender is located in a proper position.

- Solid blue: Proper position.
- Solid yellow: Fair position. Move the extender closer to the router.
- Solid red: Poor position. Move the extender closer to the router.

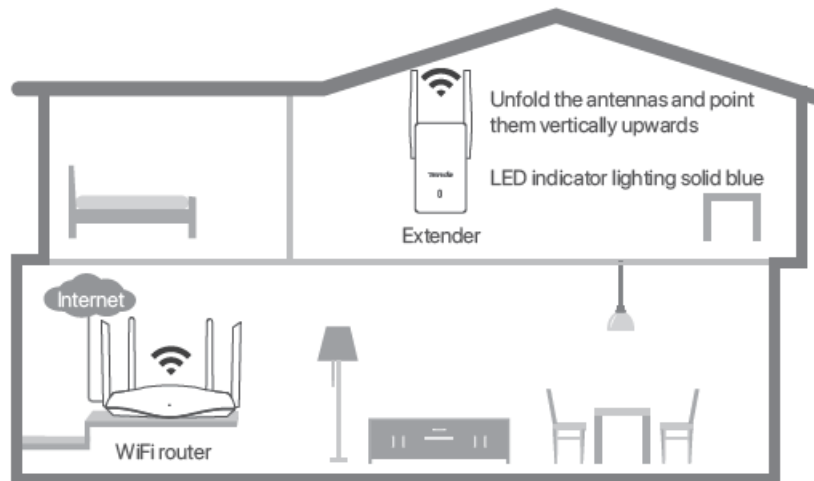

## Connect to the extender

### WiFi Name

- Extender mode: The WiFi name you set or the WiFi name of the router
- AP mode: The WiFi name you set

### WiFi Password

- Extender mode: Same as the router
- AP mode: The WiFi password you set

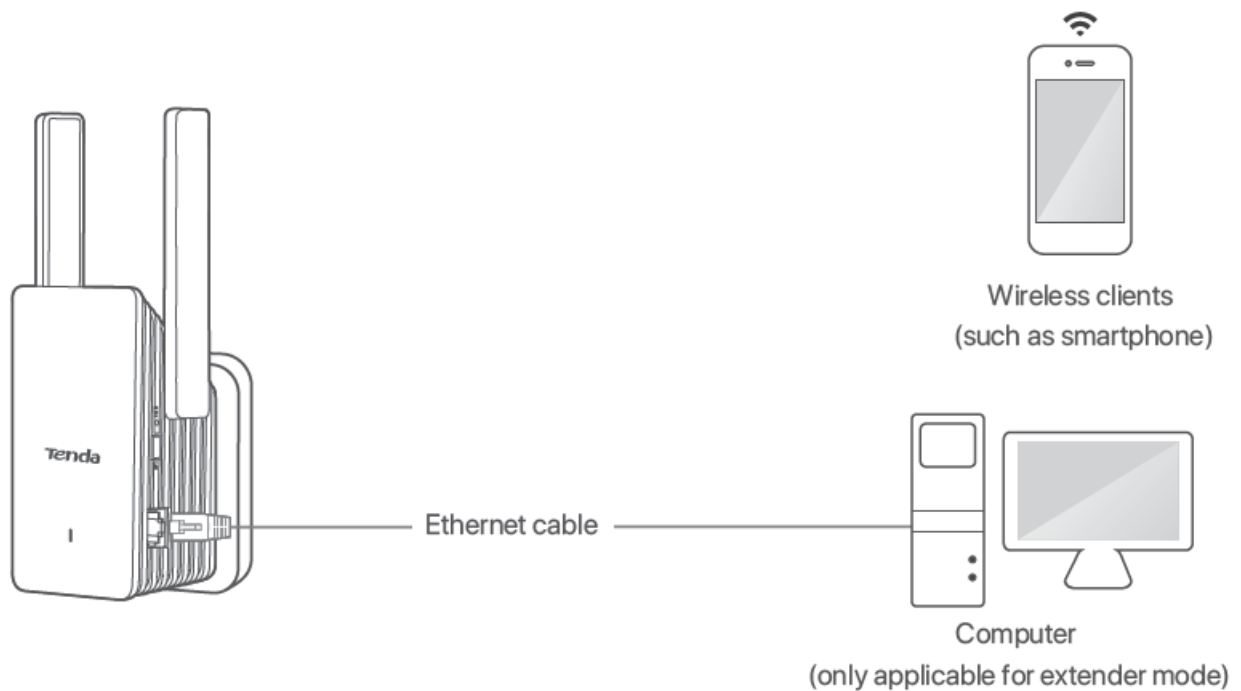

## FAQ



**Q1. I cannot log in to the web UI of the extender. What should I do?**

**A1. Try the following solutions:**

**Before extension:**

- If you are using a wireless client, such as a smartphone:
- Ensure that your smartphone has connected to the WiFi network of the extender: Tenda\_EXT.
- Ensure that the Mobile Data (if any) function is disabled.
  - If you are using a wired device, such as a computer, ensure that your computer is set to Obtain an IP address automatically and Obtain DNS server address automatically.
  - Reset the extender, and then login again. After extension:
  - If you are using a wireless client, such as a smartphone, ensure that your smartphone has connected to the WiFi network of the extender: The WiFi name is the same as the upstream router by default unless you have customized the extender WiFi name. When the WiFi name of the extender is the same as the upstream router, please stand nearby the extender and connect to its WiFi network (the extender should not be too close to the router).
  - If you are using a wired device, such as a computer, ensure that your computer is set to Obtain an IP address automatically and Obtain DNS server address automatically.

**Q2. How to reset the extender?**

A2. When the extender completes startup, press the RESET button using a needle-like item (such as a pin) for about 1 to 3 seconds. When the LED indicator blinks blue, the extender is reset successfully.

**Q3. My extender cannot find the WiFi network of my router. What should I do?**

**A3. Try the following solutions:**

- Ensure that your smartphone can detect the WiFi network of your router.
- Change the channel of your router, and try again.
- Change the encryption type of the router to WPA-PSK or WPA2-PSK, and try again.

**Q4. I cannot find the WiFi name of the extender after extending the network successfully (the LED indicator is solid blue), what should I do?**

A4. The possible reason is that you did not customize the extender WiFi name when extending the network. In this case, the WiFi name of the extender is the same as the upstream router after the extension is successful.

## Appearance

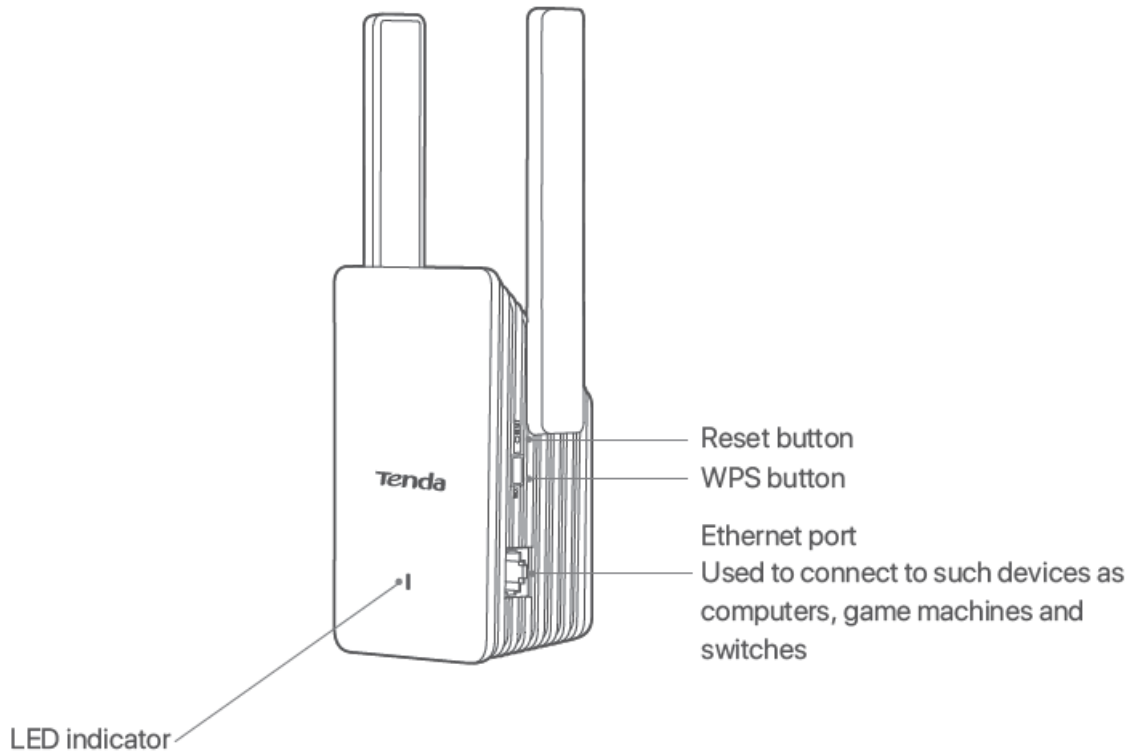

- Solid blue: Extended successfully. Proper position or too close to the router
- Solid yellow: Extended successfully. Fair position. Move the extender closer to the router
- Solid red: Extended successfully. The extender is too far away from the router
- Blinking red slowly: Startup Completes. Not extended or failed to extend
- Blinking red fast: Extending by WPS button

## FCC Statement

This equipment has been tested and found to comply with the limits for a Class B digital device, pursuant to Part 15 of the FCC Rules. These limits are designed to provide reasonable protection against harmful interference in a residential installation. This equipment generates, uses and can radiate radio frequency energy and, if not installed and used in accordance with the instructions, may cause harmful interference to radio communications. However, there is no guarantee that interference will not occur in a particular installation. If this equipment does cause harmful interference to radio or television reception, which can be determined by turning the equipment off and on, the user is encouraged to try to correct the interference by one or more of the following measures:

- Reorient or relocate the receiving antenna.
- Increase the separation between the equipment and receiver.
- Connect the equipment into an outlet on a circuit different from that to which the receiver is connected.
- Consult the dealer or an experienced radio/TV technician for help.

### **The device is for indoor usage only.**

Operation is subject to the following two conditions: (1) this device may not cause harmful interference, and (2) this device must accept any interference received, including interference that may cause undesired operation.

## Radiation Exposure Statement

This device complies with FCC radiation exposure limits set forth for an uncontrolled environment and it also complies with Part 15 of the FCC RF Rules.

This equipment should be installed and operated with a minimum distance of 20cm between the device and your

body.

**Caution:**

Any changes or modifications not expressly approved by the party responsible for compliance could void the user's authority to operate this equipment. This transmitter must not be co-located or operating in conjunction with any other antenna or transmitter. Operating frequency: 2412-2462MHz, 5150-5350MHz, 5725-5850MHz

**NOTE:**

(1) The manufacturer is not responsible for any radio or TV interference caused by unauthorized modifications to this equipment. (2) To avoid unnecessary radiation interference, it is recommended to use a shielded RJ45 cable.

**Safety Precautions**

Before performing an operation, read the operation instructions and precautions to be taken, and follow them to prevent accidents. The warning and danger items in other documents do not cover all the safety precautions that must be followed. They are only supplementary information, the installation and maintenance personnel need to understand the basic safety precautions to be taken.

1. Do not use this apparatus near water.
2. Clean only with dry cloth.
3. Do not block any ventilation openings, such as newspapers, tablecloths, curtains, etc.
4. Do not install near any heat sources such as radiators, heat registers, stoves or other apparatus that produce heat.
5. Do not damage the ground conductor or operate the device in the absence of a well-installed ground conductor. Conduct the appropriate electrical inspection.
6. Protect the power cord from being walked on or pinched particularly at the plugs, convenience receptacles, and at the point where they exit from the apparatus.
7. Only use attachments/accessories specified by the manufacturer.
8. Unplug this apparatus during lightning storms or when unused for long periods of time.
9. The mains plug is used as the disconnect device, the disconnect device shall remain readily operable.
10. Refer all servicing to qualified service personnel. Servicing is required when the apparatus has been damaged in any way, such as power-supply cord or plug is damaged, liquid has been spilled or objects have fallen into the apparatus, the apparatus has been exposed to rain or moisture, does not operate normally, or has been dropped.
11. Warning: To reduce the risk of fire or electric shock, do not expose this apparatus to rain or moisture. The apparatus shall not be exposed to dripping or splashing.
12. Warning: To reduce the risk of electric shock, do not remove the cover as there are no user-serviceable parts inside. Refer servicing to qualified personnel.

**CE Mark Warning**

This is a Class B product. In a domestic environment, this product may cause radio interference, in which case the user may be required to take adequate measures. Operations in the 5.15-5.25GHz band are restricted to indoor use only. This equipment should be installed and operated with a minimum distance of 20cm between the device and your body. The mains plug is used as a disconnect device, the disconnect device shall remain readily operable.

**NOTE:**

(1) The manufacturer is not responsible for any radio or TV interference caused by unauthorized modifications to this equipment. (2) To avoid unnecessary radiation interference, it is recommended to use a shielded RJ45 cable.

## Declaration of Conformity

Hereby, SHENZHEN TENDA TECHNOLOGY CO., LTD. declares that the radio equipment type A27 is in compliance with Directive 2014/53/EU. The full text of the EU declaration of conformity is available at the following internet address: <http://www.tendacn.com/en/service/download-cata-101.html> Operating Frequency: 2.4 GHz: EU/2412-2472MHz (CH1-CH13) 5 GHz: 5150-5350MHz, 5470-5725MHz, 5725-5850MHz (CH36-CH165) EIRP Power (Max.): 2.4 GHz: < 20dBm 5 GHz: < 22dBm Software Version: V16.03.17.05 For EU/EFTA, this product can be used in the following countries:

## RECYCLING

This product bears the selective sorting symbol for waste electrical and electronic equipment (WEEE). This means that this product must be handled pursuant to European directive 2012/19/EU in order to be recycled or dismantled to minimize its impact on the environment.

The user has the choice to give his product to a competent recycling organization or to the retailer when he buys new electrical or electronic equipment.

Operating Temperature: 0°C – 40°C

Operating Humidity: (10% – 90%) RH, non-condensing

## Technical Support

Shenzhen Tenda Technology Co., Ltd. 6-8 Floor, Tower E3, NO.1001, Zhongshanyuan Road, Nanshan District, Shenzhen, China. 518052 USA hotline: 1-800-570-5892 Canada hotline: 1-888-998-8966 Toll-Free: 7 x 24 hours Toll-Free: Mon – Fri 9 am – 6 pm PST Hong Kong hotline: 00852-81931998 Global hotline: +86 755-2765 7180 (China Time Zone) Website: [www.tendacn.com](http://www.tendacn.com) E-mail: [support.nova@tenda.com.cn](mailto:support.nova@tenda.com.cn)

## Copyright

© 2021 Shenzhen Tenda Technology Co., Ltd. All rights reserved. Tenda is a registered trademark legally held by Shenzhen Tenda Technology Co., Ltd. Other brand and product names mentioned herein are trademarks or registered trademarks of their respective holders. Specifications are subject to change without notice.

## Documents / Resources

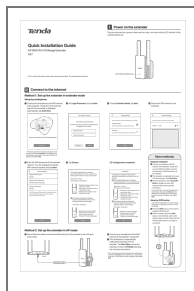
	<p><a href="#">Tenda AX1800 Wi-Fi 6 Range Extender</a> [pdf] Installation Guide AX1800, Wi-Fi 6 Range Extender, AX1800 Wi-Fi 6 Range Extender</p>
---	---