

Skydio Gen 3 Dual Band Module Software



Skydio Gen 3 Dual Band Module Software User Manual

[Home](#) » [Skydio](#) » Skydio Gen 3 Dual Band Module Software User Manual 

Contents

- [1 Skydio Gen 3 Dual Band Module Software](#)
- [2 Product Usage Instructions](#)
- [3 FAQs](#)
- [4 Q: How can I ensure proper thermal management for the module?](#)
 - [4.1 Overview](#)
 - [4.2 Module Integration](#)
 - [4.3 Antenna Connectors](#)
 - [4.4 Antenna Installation](#)
 - [4.5 Thermal Management](#)
 - [4.6 Usage Guidelines](#)
 - [4.7 Mechanical Drawings](#)
 - [4.8 Compliance Information](#)
 - [4.9 IC](#)
- [5 Documents / Resources](#)
 - [5.1 References](#)



Skydio Gen 3 Dual Band Module Software

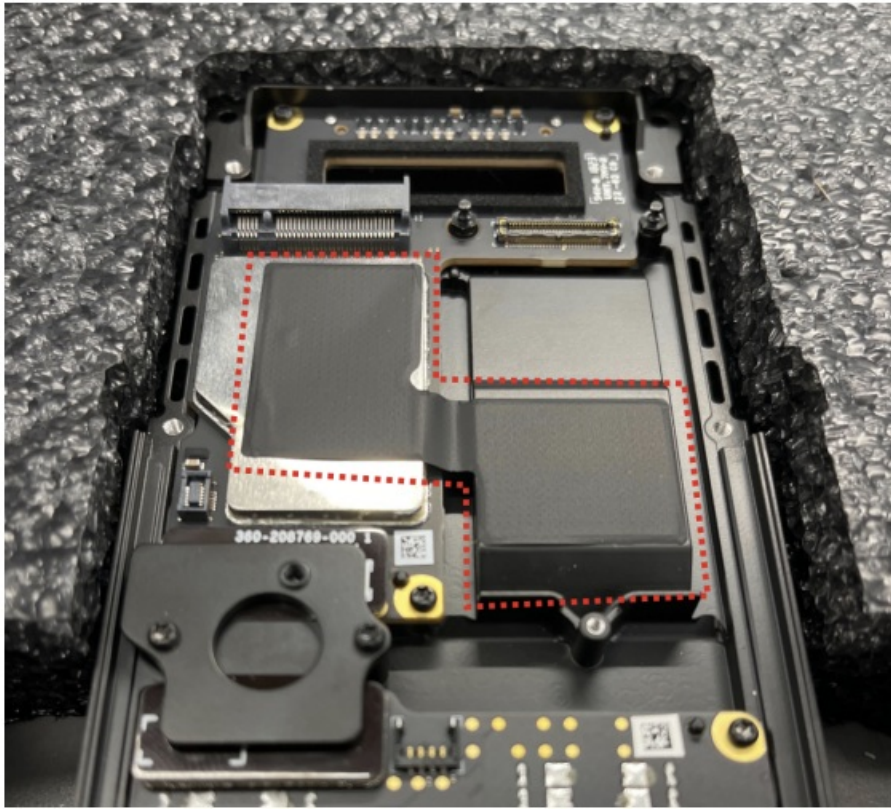

Specifications

- Model: SkydioLink Gen 3 Dual Band Module
- Version: 1.1 (2023/08/15)

Product Information

Overview

The SkydioLink Gen 3 Dual Band module is designed to provide reliable dual-band connectivity for end devices.

Integration module

The module integrates with end devices using board-to-board connectors and requires proper ESD protection during installation.

Pinout & Power Requirements

All power and control signals are transmitted through the J3000 pinout. Ensure correct mating board-to-board connectors are used.

Mechanical Integration Module

The module securely attaches using Hirose FX12B-60P-0.4SV connectors on the lower side.

Antenna Connectors

The module features I-PEX u.FL connectors for external antennas, ensuring easy installation without screws.

Thermal Management

To prevent overheating, utilize heat sinking via the shield can on top of the module, transferring heat away from critical components.

Product Usage Instructions

Antenna Installation Guidelines

1. Install the antenna at least 20 cm away from users.
2. Avoid co-locating the transmitter module with other transmitters or antennas.
3. Use only antennas of the same type with equal or lower gains as specified to maintain compliance.

Host Device Requirements

Ensure the host device meets the necessary specifications to support the SkydioLink Gen 3 Dual Band module.

Regional Settings

Configure regional settings according to regulatory requirements for optimal performance and compliance.

FAQs

Q: What should I do if I cannot meet the antenna installation guidelines?A: If unable to meet the guidelines, re-evaluate the product configuration and seek additional authorization to ensure compliance.

Q: How can I ensure proper thermal management for the module?

A: Use heat sinking methods like a graphite strap to transfer heat away from components and prevent overheating.

SkydioLink Gen 3 Dual Band Module User Manual

version 1.1 (2023/08/15)

Overview

This document provides integration, installation and usage instructions for the SkydioLink Gen 3 Dual Band module.

Module Integration

Pinout & power requirements

All module power and control signals are passed from the end device to the module over J3000, following the below pinout:

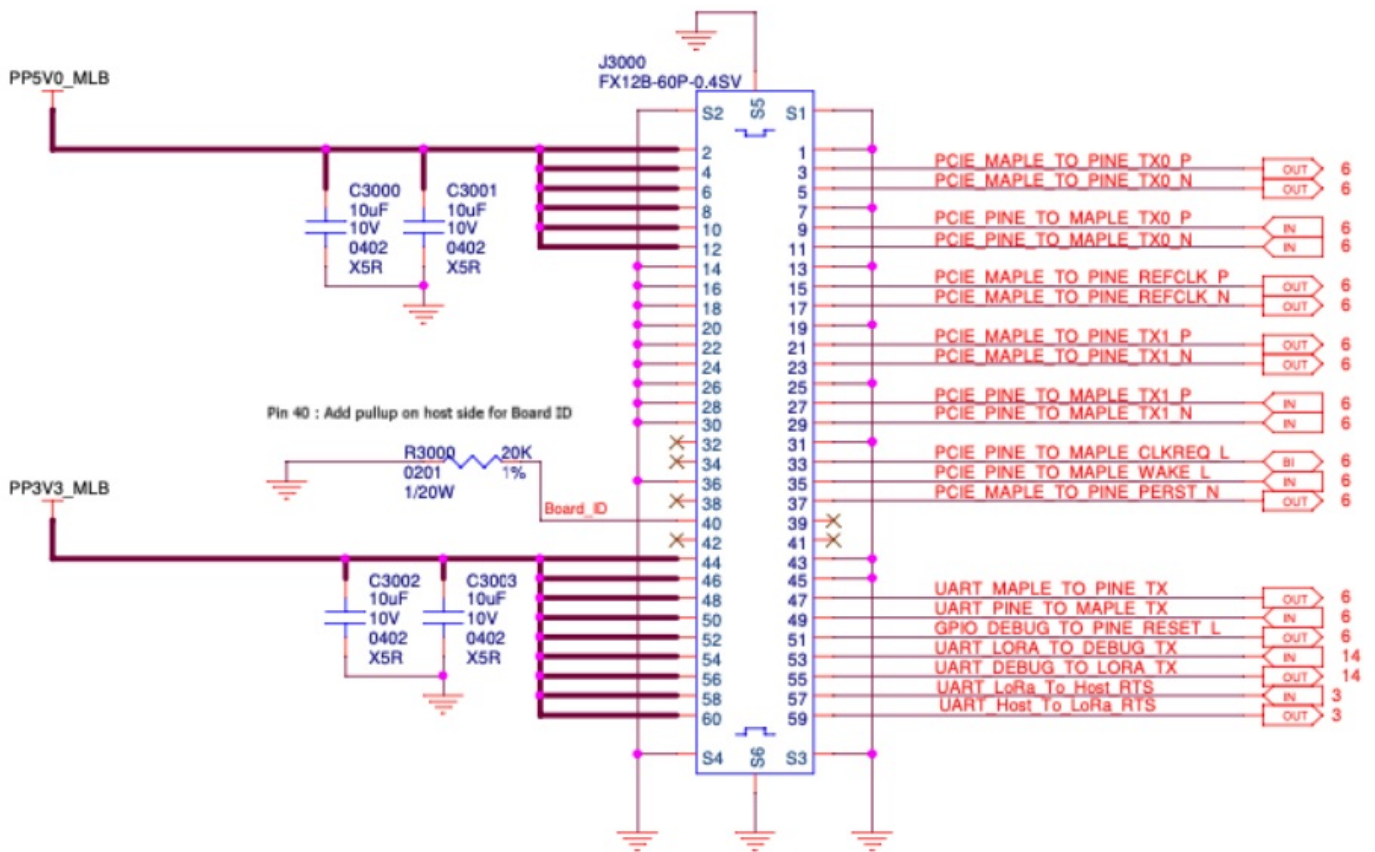

Module Mechanical Integration

The SkydioLink Gen 3 Dual Band module snaps into place using the two board to board connectors (Hirose FX12B-60P-0.4SV) on the lower side of the module.

When installing the module, it is important to ensure that the technician using ESD protection

On the end device, the board to board connector manufacturer part number must match the module side specifications:

Mating board to board type: FX12B-60S-0.4SV

Antenna Connectors

- The radio module uses two I-PEX u.FL connectors (20279-001E-03) to connect external antennas to the module. The connectors are snapped in place, and do not require any external pressure or screws.
- On the antenna cable, the mating connector is an I-PEX 20278-112R series (or equivalent) connector. Antenna types and gains must follow the FCC / IC regulatory filings submitted by Skydio.

Antenna Installation

1. The antenna must be installed such that 20 cm is maintained between the antenna and users,
2. The transmitter module may not be co-located with any other transmitter or antenna.
3. Only antennas of the same type and with equal or less gains as shown below may be used with this module. Other types of antennas and/or higher gain antennas may require additional authorization for operation.

	Antenna type	2.4GHz band Peak Gain (dBi)	5.2GHz band Peak Gain (dBi)	5.3GHz band Peak Gain (dBi)	5.5GHz band Peak Gain (dBi)	5.8GHz band Peak Gain (dBi)
Low Gain Antenna	Dipole	Ant. 0: 1.91 Ant. 2: 1.9	Ant. 0: 1.35 Ant. 2: 1.33	Ant. 0: 1.9 Ant. 2: 2.1	Ant. 0: 1.33 Ant. 2: 1.37	Ant. 0: 1.4 Ant. 2: 1.35
High Gain Antenna	Dipole	Ant. 0: 4.57 Ant. 2: 4.62	Ant. 0: 7.47 Ant. 2: 5.84	Ant. 0: 7.76 Ant. 2: 6.46	Ant. 0: 6.84 Ant. 2: 5.42	Ant. 0: 7.33 Ant. 2: 6.03

In the event that these conditions cannot be met (for example certain laptop configurations or co-location with another transmitter), then the FCC/IC authorization is no longer considered valid and the FCC ID/IC ID cannot be used on the final product. In these circumstances, the OEM integrator will be responsible for re-evaluating the end product (including the transmitter) and obtaining a separate FCC/IC authorization.

Thermal Management

In order to prevent overheating when operating at high power levels, it is important to move heat out of the module. It is recommended to heat sink via the shield can on the top of the module, which has a direct thermal interface to the radio & front end module components that generate the most heat.

An example of this is shown below, using a graphite strap to move heat from the module.



Usage Guidelines

Power & frequency settings should not be exposed to the user, and should be set at the factory to ensure that the module is correctly configured relative to the regulatory filings submitted by Skydio.

Host Device Requirements

- This module should only be used in pre-approved Skydio host devices. Any additional host devices must go through an approval process completed by Skydio.
- This module should only be used in pre-approved antennas. Any additional host devices must go through an approval process completed by Skydio.
- The module should only be used in host devices with GNSS sensing capability to supplement the geo-location data to determine the correct regulatory region power and operating limits.
- The host product needs to provide a physical or e-label per FCC KDB 784748. All standalone modules without an integrated display on the module must be labeled with the module's FCC ID. Only modules with a display can use e-labeling (see also KDB Publication 784748 D02). A host product shall use a physical label stating "Contains FCC ID: 2ATQRSMODBV3," or shall use e-labeling.
- Based upon FCC Knowledge Database publication number 616217 when there are multiple transmitting devices installed in a host device, an RF exposure transmitting assessment shall be performed to determine the necessary application and test requirements. Skydio must identify all possible combinations of simultaneous transmission configurations for all transmitters and antennas installed in the host system. This includes transmitters installed in the host as mobile devices (>20 cm separation from user) . Skydio should consult the actual FCC KDB 616217 document for all details in making this assessment to determine if any additional requirements for testing or FCC approval is necessary.

Regional Settings

All power levels & frequency bands must follow regional restrictions. Two methods can be used to ensure that these are followed:

1. During a factory installation, set the power tables based on the intended country of sale for the specific end device SKU
2. The Radio is using 802.11d scanning to establish local country code. In any case, Parameters for each country are stored separately and are applied per a specific country

Note that the end device ultimately controls power levels, frequency band and other radio settings and it is up to the end device manufacturer to ensure compliance with existing filings for this module.

Mechanical Drawings

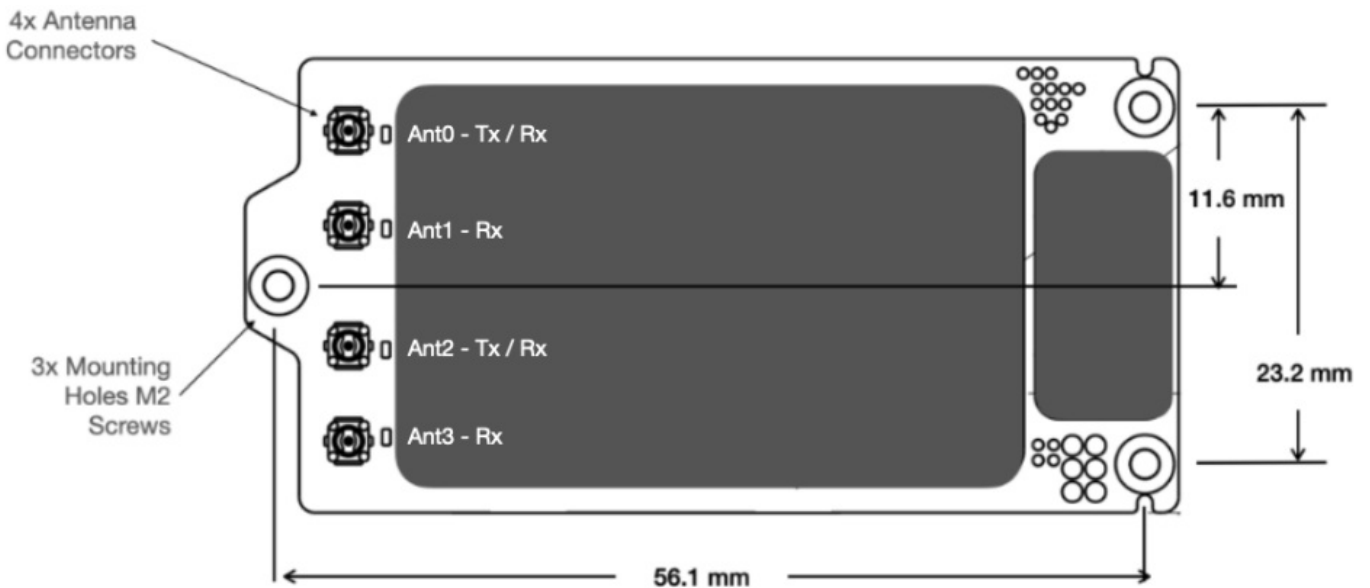
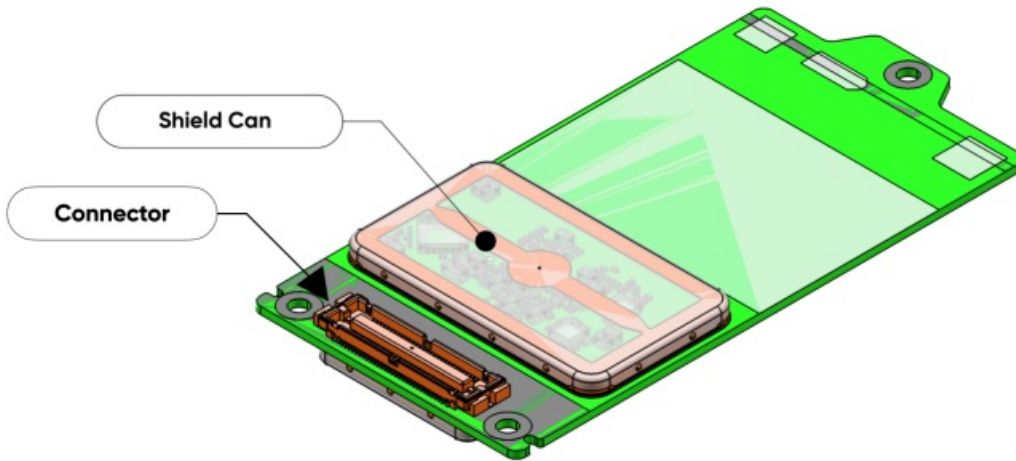
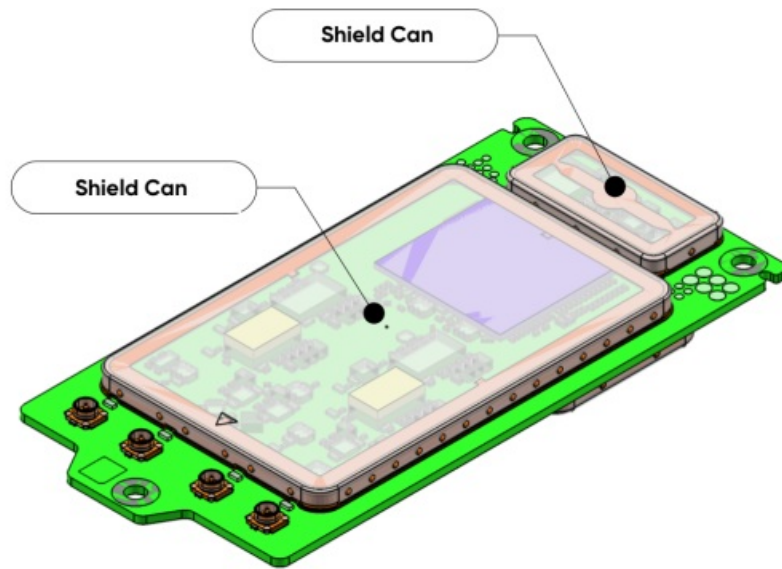

Compliance Information

FCC

Any changes or modifications to this equipment not expressly approved by Skydio for compliance will void the user's authorization to operate this equipment.

This equipment has been tested and found to comply with the limits for a Class B digital device, pursuant to Part 15 of the FCC Rules. These limits are designed to provide reasonable protection against harmful interference in a

residential installation. This equipment generates, uses and can radiate radio frequency energy and, if not installed and used in accordance with the instructions, may cause harmful interference to radio communications. However, there is no guarantee that interference will not occur in a particular installation. If this equipment does cause harmful interference to radio or television reception, which can be determined by turning the equipment off and on, the user is encouraged to try to correct the interference by one of the following measures:

- Reorient or relocate the receiving antenna.
- Increase the separation between the equipment and receiver.
- Connect the equipment into an outlet on a circuit different from that to which the receiver is connected.
- Consult the dealer or an experienced radio/TV technician for help.

This device complies with part 15 of the FCC Rules. Operation is subject to the following two conditions: (1) This device may not cause harmful interference, and (2) this device must accept any interference received, including interference that may cause undesired operation.

This equipment complies with FCC radiation exposure limits set forth for an uncontrolled environment. The distance between user and products should be no less than 20cm. The end user must follow the specific operating instruction for satisfying RF exposure compliance. This transmitter must not be co-located or operating in conjunction with any other antenna or transmitter.

This module is only FCC authorized for the rule parts Part 15.247 and 15.407 listed on the grant. The OEM integrator is responsible for additional system-level EMI/EMC and product safety testing and certification that applies in the U.S. and other countries to the host system containing the Module. This includes, but is not limited to, FCC Part 15 Class B Digital Emissions, ISED Interference-Causing Equipment Standards, and others. These system-level EMC tests are to be done with the Module installed and included in the scope of the submission.

IC

The installer of this radio equipment must ensure that the antenna is located or pointed such that it does not emit RF field in excess of Health Canada limits for the general population; consult Safety Code 6, obtainable from Health Canada's website www.hc-sc.gc.ca/rpb

This device contains license-exempt transmitter(s)/receiver(s) that comply with Innovation, Science and Economic Development Canada's license-exempt RSS(s). Operation is subject to the following two conditions:

- This device may not cause interference.
- This device must accept any interference, including interference that may cause undesired operation of the device.

Documents / Resources

	<p>Skydio Gen 3 Dual Band Module Software [pdf] User Manual 2ATQRSMODBV3, smodbv3, Gen 3 Dual Band Module Software, Dual Band Module Software, Module Software, Software</p>
-------------------------------------------------------------------------------------	--------------------------------------------------------------------------------------------------------------------------------------------------------------------------------------------------

References

- [User Manual](#)

Manuals+. Privacy Policy

This website is an independent publication and is neither affiliated with nor endorsed by any of the trademark owners. The "Bluetooth®" word mark and logos are registered trademarks owned by Bluetooth SIG, Inc. The "Wi-Fi®" word mark and logos are registered trademarks owned by the Wi-Fi Alliance. Any use of these marks on this website does not imply any affiliation with or endorsement.