



RADIO BRIDGE Wireless Vibration Sensor User Guide

[Home](#) » [RADIO BRIDGE](#) » RADIO BRIDGE Wireless Vibration Sensor User Guide 



Wireless Vibration Sensor
User Guide
VERSION 1.4
SEPTEMBER 2020

Contents

- 1 QUICKSTART
- 2 OVERVIEW
- 3 Revision History
- 4 TECHNICAL SPECIFICATIONS
- 5 BATTERY LIFE
- 6 TEXT MESSAGES
- 7 MESSAGE PROTOCOL
 - 7.1 Control Byte
 - 7.2 Periodic Reports
 - 7.3 Scaling Factor
 - 7.4 Auto Scaling
 - 7.5 Sampling Duration
- 8 MECHANICAL DRAWINGS
- 9 REGULATORY AND COMPLIANCE
- 10 CUSTOMER SUPPORT
- 11 DISCLAIMERS
- 12 LEGAL NOTICES
- 13 TRADEMARKS AND COPYRIGHT
- 14 Documents / Resources
- 15 Related Posts

QUICKSTART

To start using your sensor, simply go to:

<https://console.radiobridge.com>

From here you can register your device and immediately start receiving messages. The sensor configuration, message monitoring, and setting up alerts is usually self-explanatory through the user interface. For further explanations of any sensor features, you may refer to this user guide

OVERVIEW

2.1. Sensor Overview

The wireless sensors designed and manufactured by Radio Bridge provide a full sensor to cloud solutions for the Internet of Things (IoT) applications. The high-bandwidth vibration sensor measures vibration speed at low-frequency ranges (10Hz – 1kHz), and peak g-force at high-frequency ranges (1.5kHz – 10kHz). The sensor can support between one and four independent vibration inputs referred to as “channels” in this document. The vibration sensor can be used for simple motor on/off functionality, or vibration analysis utilizing ISO standards such as ISO 10816. The high frequencies are used for more advanced analysis not specified in ISO standards.

Features include:

- Built-in radio that talks directly with LoRaWAN wireless networks
- Two types of tamper detection: enclosure tamper and wall mount tamper
 - Enclosure tamper detects if the packaging of the sensor itself is opened or broken Available on the RBSx01, RBSx05, and RBSx06 sensors.
 - Wall mount tamper detects if the sensor has been removed from the wall or mounting point. Available on the RBSx01 and RBSx05 sensors.
- 200,000+ transmissions on a single battery and a 5-10 year battery life depending on usage. See the Battery section for more detail.
- Fully integrated internal antenna
- Over the air sensor configuration in the field
- Automatic low battery reporting and supervisory messages



Revision History

Table 1 Revision History

Revision	Date	Description
1.0	February 2020	The initial release of the document
1.1	June 2020	Updated payloads
1.2	July 2020	Added the fourth channel
1.3	August 2020	Added separate configs for LF and HF sample times, and added bias voltage
1.4	September 2020	Reporting total and peak FFT energy from specified frequency bands

Document Conventions

Table 2 Document Conventions

Font / Icon	Meaning
	Important notes
	Warnings and cautions

Part Numbers

Table 3 Part Numbers

Part Number	Rating	Wireless	Region
RBS306-VSHB-US	Outdoor/Industrial	LoRaWAN	North America, South America

TECHNICAL SPECIFICATIONS

3.1. Absolute Maximum Ratings

Parameter	Rating	Units
Operating ambient vibration (radio and plastic housing)	-40 to +70	°C
Storage ambient vibration (radio and plastic housing)	-40 to +100	°C

BATTERY LIFE

This device uses a lithium non-rechargeable battery and is capable of 200,000+ total messages depending on the wireless standard and usage. For an accurate estimate of battery life, please refer to the “Sensor Battery Estimator.xlsx” spreadsheet on the Radio Bridge website. This spreadsheet combines usage information such as the average number of messages per day and estimates the battery life for a particular device.



Refer to the spreadsheet “Sensor Battery Estimator.xlsx” on the Radio Bridge website for specific battery life estimates.

The power required for message transmission is much greater than the “sleep current” (the power consumed when the device is inactive) for high-power radio technologies such as LoRaWAN. This means that the battery life for most devices is primarily dependent on the number of transmissions per day. Different battery types will deplete over time with different voltage profiles. For instance, a lithium battery will maintain a relatively high voltage for the life of the battery and then experience a rapid drop near the end, whereas an alkaline battery will experience a more gradual reduction in voltage over time. Radio Bridge devices are shipped with lithium batteries, and these are recommended when the battery needs to be eventually replaced. Temperature also plays a role in battery life. The battery life estimates in the online spreadsheet assume room temperature, but temperatures close to the maximum and minimum ratings will have a negative impact on battery life. For example, battery voltage tends to be lower in cold temperatures and the internal circuitry needs a certain minimum voltage to

operate properly before it will shut down. Thus, battery life will tend to be shorter when running the device in cold environments.



The battery voltage will be lower in cold temperatures and thus battery life will be reduced in cold environments.

The battery voltage is reported by the supervisory messages as well as a low battery indicator. See the section on Message Protocol for more detail.

TEXT MESSAGES

The device can be triggered to send test messages by placing a magnet next to the side of the enclosure. The location of the magnet is indicated by the triangular notch on the side of RBSx01 and RBSx05 sensors. RBSx04 sensors do not have this capability. There is a small magnetic Hall effect sensor that will detect the presence of a magnet and send a message. This can be used for diagnostic purposes to ensure the sensor is within range and connected to the network.

MESSAGE PROTOCOL

This section defines the protocol and message definitions for the device.



Radio Bridge provides a web-based console at console.radiobridge.com to configure and monitor devices. Usage of this console is highly recommended for most customers rather than implementing the protocols defined in this section.

If the standard Radio Bridge console (console.radiobridge.com) is not used, refer to this section to decode the device data and configure the device through downlink messages.

Common Messages

There are common messages across all wireless devices that are defined in the document “Common Sensor Messages” which is available on the Radio Bridge website.



Refer to the document “Common Sensor Messages” for definitions of all common messages. Common messages are not defined in this document.

Common messages include basic error messages, tamper, supervisory, and downlink ack. It is important to refer to that document prior to decoding the messages defined in this section.

Uplink Messages

The uplink messages (sensor to a web application) specific to the vibration sensors are defined in this section. The common uplink messages are not included in this section (see common messages document).

Vibration Event

The table below describes the vibration event uplink messages for each channel, all containing the low-frequency vibration and the high-frequency vibration data. Note that each channel is divided into its own message where ID of 0x1C is Channel 1, ID 0x1D is Channel 2, ID 0x1E is Channel 3, and ID 0x1F is Channel 4.

Table 5 Uplink Message 0x1C, 0x1D, 0x1E, and 0x1F Vibration Events

Byte	Description
0	Vibration Event Payload (see Vibration Event Payload Definitions)
1	Low-frequency vibration peak velocity in inches/sec in the given channel
2	High-frequency vibration peak g-force in the given channel
3	The temperature of the accelerometer probe (signed two's complement)
4	The bias voltage of the sensor

The vibration event is defined in the following table. Table 6 Vibration Event Payload Definitions

Event Payload	Description
0x00	Periodic report
0x01	High-frequency vibration has risen above the upper threshold
0x02	High-frequency vibration has fallen below the lower threshold
0x03	Low-frequency velocity has risen above the upper threshold
0x04	Low-frequency velocity has fallen below the lower threshold
0x05	Accelerometer exceeded g-force range (see Scaling Factor in downlink section)

All velocity values for the low-frequency vibration sensor are in units of inches/sec and represent peak value derived from the root-mean-squared calculation: $\text{peak velocity} = \text{RMS} * 1.414$. The low-frequency velocity values must be divided by 100 to obtain the value in inches/sec. For example, if the low-frequency peak velocity byte is 0x6E or 110 decimal, the velocity is 1.1 in/sec. The high-frequency g-force values must be divided by 4 to obtain the value in g-force. For example, if the high-frequency byte is 0x0A or 10 decimal, the peak g-force is 2.5g. The range for the temp sensor is 0C to 100C. The bias voltage should sit at the midpoint of the voltage reference to the accelerometer.

For example, if the accelerometer is powered at 3.3V, the bias should be 1.65V. If the bias voltage is not at this midpoint, it could indicate a cabling issue, a broken accelerometer, or some other problem in the system. The bias voltage byte in the uplink message must be divided by 100 to obtain the actual value. For example, if the bias voltage byte is 0xA5 or 165 decimal, the bias voltage is 1.65V.

Condensed FFT

FFTs are important for identifying specific conditions in vibration analysis, but sending a full FFT over a LoRaWAN network is not feasible with respect to payload sizes, power

consumption, on-air time, and other considerations. Thus, the vibration sensor sends a “Condensed FFT” which provides both total energy and peak energy from specific frequency bands in the FFT. The following table defines the eight bands that are reported:

Table 7 Frequency Bands for Condensed FFT

Band	Frequencies
0	10-20Hz
1	21-40Hz
2	41-55Hz
3	56-70Hz
4	71-110Hz
5	111-130Hz
6	131-230Hz
7	231Hz+

The frequency ranges in the above table represent important bands required for diagnosing common failure conditions. For all of the eight bands, a total energy value is reported which is the sum of all bins in the FFT between those two frequencies, and a peak energy value which is just the peak value from a single bin between the two frequencies. The uplink messages for the condensed FFT are shown in the table below

Table 8 Uplink Message 0x20 Condensed FFT

Byte	Description
0	Payload definition byte Bits 7:4 Payload type (see Condensed FFT Payload Definitions) Bits 3:0 Channel (0x00, 0x01, 0x02, or 0x03)
1-2	Value for frequency band 0 or 4
3-4	Value for frequency band 1 or 5
5-6	Value for frequency band 2 or 6
7-8	Value for frequency band 3 or 7

Table 9 Payload Type nibble, bits 7:4 of the Payload Definition Byte

Payload Type	Description
0x0	Total energy values, bands 0-3 in bytes 1-8 (16-bit values)
0x1	Total energy values, bands 4-7 in bytes 1-8 (16-bit values)
0x2	Peak energy values, bands 0-3 in bytes 1-8 (16-bit values)
0x3	Peak energy values, bands 4-7 in bytes 1-8 (16-bit values)

In the condensed FFT message, bytes 1-8 contain four 16-bit values. For example, if the sensor is reporting a peak energy value of 300 in the frequency band 5 of channel 1, the payload definition byte would be 0x31, and bytes 3-4 would be 0x012C (300 decimal).

Downlink Messages

The downlink message (web application to the sensor) specific to the vibration sensors is defined in this section. The common downlink messages are not included in this section (see common messages document). The low-frequency and high-frequency sensors are divided into two downlink messages, as some products may contain one or the other, or both. The table below describes the configuration used for each channel.

Table 10 Low-Frequency Vibration Downlink Configuration Messages 0x1C, 0x1D, 0x1E, 0x1F

Byte	Description
0	Control byte (see Control Byte below)
1	Periodic reporting (see Periodic Reports below)
2	Low-frequency upper threshold in inches/second
3	Low frequency lower threshold in inches/second
4	High-frequency upper threshold in g-force
5	High frequency lower threshold in g-force
6	Sampling duration (see Sampling Duration section below)

The configuration defined above is the same for each channel. Using ID 0x1C configures Channel 1, ID of 0x1D configures Channel 2, ID 0x1E configures Channel 3, and ID 0x1F configures Channel 4. All velocity values in the low-frequency sensor are in units of inches/sec and represent peak value derived from the root-mean-squared calculation: $\text{peak velocity} = \text{RMS} * 1.414$. The desired low-frequency velocity threshold values must be multiplied by 100 for the configuration value. For example, if the desired low-frequency threshold is 1.1 in/sec, then the threshold value would be 110 or 0x6E. Thus, the resolution of the velocity values is 0.01 in/sec with a max value of 2.55 in/sec. The desired high-frequency g-force threshold values must be multiplied by 4 for the configuration value. For example, if the desired high-frequency threshold is 2.5g, then the threshold value would be 10 or 0x0A. Thus, the resolution of the g-force values is 0.25g with a max value of 63.75g. A value of zero in any of the above threshold values disables the reporting of that event.

Control Byte

The control byte for both downlink messages is defined in the following table.

Table 11 Control Byte from the Downlink Configuration Message

Bit	Description
0-3	Unused
4-6	Scaling factor (see Scaling factor section)
7	Auto-scaling (see Auto Scaling section). Set to 1 if auto-scaling is on, 0 if it is disabled.

Periodic Reports

The vibration sensor can also send periodic updates, and this is defined in byte 1 of both sensor downlinks. A

setting of 0 will disable periodic reporting. The period is defined in 1-hour increments when the most significant bit is 0, and it is defined in 1-minute increments when the most significant bit is 1 as shown in the following table.

Table 12 Period Bye from Downlink Configuration Message

Bit 7	Bits 6:0
0	The period defined in hours (1-127 hours)
1	The period defined in minutes (1-127 minutes)

For example, to receive a report every 4 hours, byte 1 would be set to 0x04. To receive a periodic report every 15 minutes, byte 1 would be set to 0x8f.

Scaling Factor

The scaling factor sets the full range of the accelerometer probe. By default, the accelerometer has a full dynamic range of +/- 40g which is much higher than most applications required. For best results, set the scaling factor as high as possible for a particular application. For example, if the max g-force expected is +/- 15g, then use the 2x scaling factor which reduces the overall range to +/- 20g and will provide results on a scale that has better resolution. If a scaling factor is too high and hits the limit of the accelerometer, an uplink message will be sent indicating that the accelerometer is out of range and you must increase the scaling factor. The scaling factor is part of the Control Byte defined above, and the two bits are defined in the following tables for the low-frequency products.

Table 13 Accelerometer Scaling Factor

Bits 6:4	Scaling Factor
000	x1 (default)
001	x2
010	x4
011	x5
100	x8
101	x10
110	x16
111	x32

The scaling factor how much to amplify the accelerometer signal. This is useful for low levels of vibration that need to be scaled up to improve the dynamic range. For example, a scaling factor of x2 (bits = 001) means that the signal is amplified by a factor of 2. If the signal is amplified too much and hits the limit of the accelerometer, a message indicating that the signal has been clipped will be sent (see uplink messages above), and if the auto-scaling is enabled the scaling factor will be automatically reduced. The Auto-Scaling feature is defined in the next section.

Auto Scaling

The scaling factor defined in the previous section sets the full range of the accelerometer, and the auto-scaling

feature defined in this section allows the vibration sensor to automatically increase the scaling based on the current levels of vibration. When enabled, the auto-scaling feature will increase the scaling if the maximum g-forces on the current sample exceed 90% of the current range. If a condition occurs where the g-force has exceeded the maximum range of the accelerometer, a message will be sent to the user (see uplink messages), the scaling factor will decrease, and the measurement will be run again with the updated scaling factor. Note that auto-scaling will only move the scale down, not up. To adjust the scaling factor up to increase resolution, see the previous section to send the corresponding downlink. To enable auto-scaling, set the corresponding bit in the control byte to 1, and set to 0 to disable. The auto-scaling is on by default.

Sampling Duration

The sampling duration byte specifies how many samples to capture before reporting a value, checking a threshold, etc. The byte is defined in the table below.

Table 14 Sampling Duration Byte from Downlink Configuration Message

Bits	Description
7:4	Low-frequency samples to average
3:0	High-frequency samples for peak detection

As shown in the above table, the sample duration can be set independently for the high frequency and low-frequency measurements. In the low-frequency measurements, the additional samples are used for spectral averaging in the frequency domain to reduce the noise floor. For high-frequency measurements, the additional samples essentially widen the window for identifying the maximum value. Generally speaking, adding additional samples will increase the maximum value because we are looking for a max value across a longer period of time. The additional samples defined in this byte all happen at the same time, ie back-to-back. For example, if the system-wide sampling rate (see the Common Messages document) is set to one hour and the low-frequency sampling duration is set to four, then every hour the sensor will take four samples and report the average value.

MECHANICAL DRAWINGS

The mechanical drawings provided in this section are for the main body of the sensor. All dimensions are inches unless otherwise noted.

ARMORED OUTDOOR/INDUSTRIAL RBSX06 SENSORS

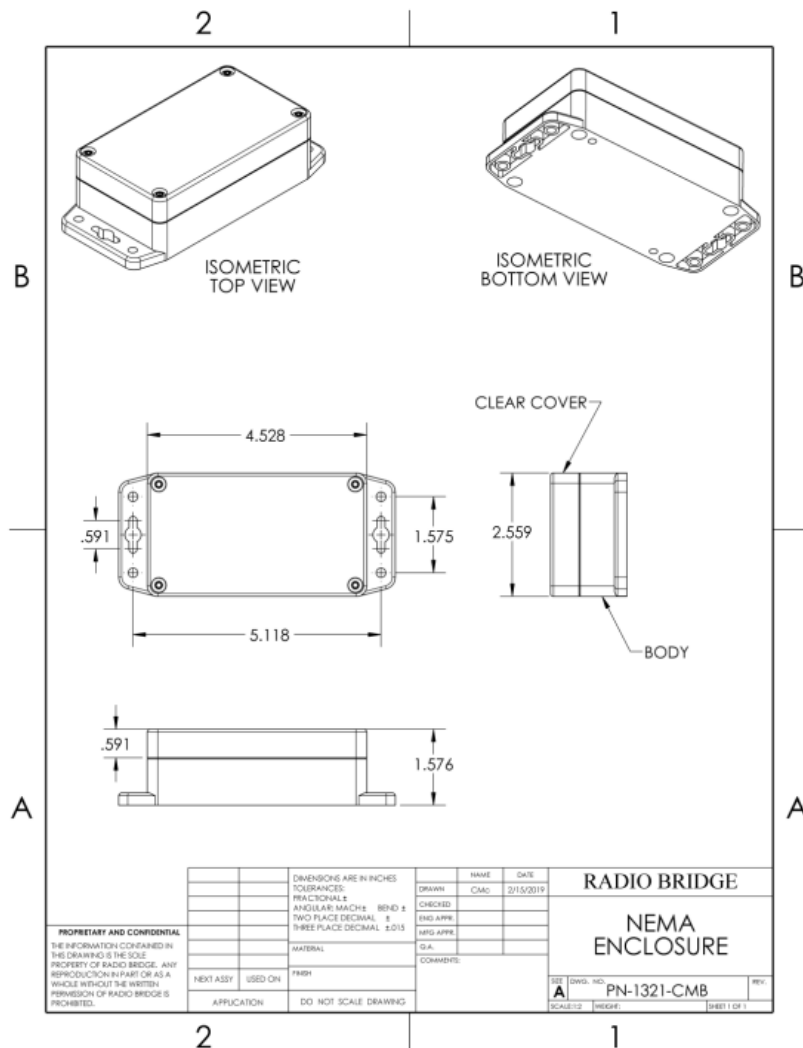

REGULATORY AND COMPLIANCE

8.1. Federal Communications Commission (FCC)

Per FCC 15.19(a)(3) and (a)(4) This device complies with part 15 of the FCC Rules. Operation is subject to the following two conditions: (1) This device may not cause harmful interference, and (2) this device must accept any interference received, including interference that may cause undesired operation. Per FCC 15.21, Changes or modifications not expressly approved by Radio Bridge could void the authority to operate the devices. Sigfox RBS101, RBS104, and RBS105 sensors FCC ID: 2APNUSFM10R2 LoRaWAN RBS301, RBS304, and RBS305 sensors FCC ID: 2APNUCMABZ LoRaWAN RBS306 sensors: This device contains FCC IAU792U13A16858 This device contains equipment certified under IC: 125A-0055

8.2. Harmonized Commodity Description (HS Code)

The Harmonized Commodity Description and Coding System generally referred to as “Harmonized System” or simply “HS” is a multipurpose international product nomenclature developed by the World Customs Organization (WCO). HS Code: 8531.90.9001

8.3. Export Control Classification Number (ECCN)

ECCNs are five character alpha-numeric designations used on the Commerce Control List (CCL) to identify dual-use items for export control purposes. An ECCN categorizes items based on the nature of the product, i.e. type of commodity, software, or technology and its respective technical parameters. ECCN: 5a992.c

CUSTOMER SUPPORT

Radio Bridge offers free technical support at:

<https://support.radiobridge.com>

Radio Bridge also offers technical support plans and service packages to help our customers get the most out of their Radio Bridge products.

DISCLAIMERS

Information in this document is subject to change without notice and does not represent a commitment on the part of Radio Bridge. Radio Bridge provides this document “as is,” without warranty of any kind, expressed or implied, including, but not limited to, the implied warranties of fitness or merchantability for a particular purpose. Radio Bridge may make improvements and/or changes in this manual or in the product(s) and/or the software described in this manual at any time.

LEGAL NOTICES

See the Legal Notices section of the website for up-to-date information on Radio Bridge’s warranty, returns policy, privacy statement, terms of sale, and terms of service.

TRADEMARKS AND COPYRIGHT

Radio Bridge™, SubGig®, Armored Sensor™, and BridgeBee® are trademarks of Radio Bridge Inc in the United States. © 2019 Radio Bridge Inc. All rights reserved

COPYRIGHT © 2019, RADIO BRIDGE INC.
WIRELESS VIBRATION SENSOR

PAGE 18 OF 18

Documents / Resources

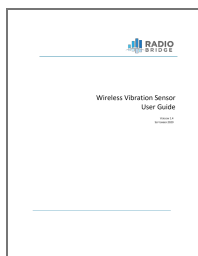
	<p>RADIO BRIDGE Wireless Vibration Sensor [pdf] User Guide Wireless Vibration Sensor, RBM101S-315</p>
---	---