



# ProBreeze PB-06 12L Compressor Dehumidifier Instruction Manual

[Home](#) » [ProBreeze](#) » ProBreeze PB-06 12L Compressor Dehumidifier Instruction Manual 

## Contents

- [1 ProBreeze PB-06 12L Compressor Dehumidifier Instruction Manual](#)
- [2 12L Compressor Dehumidifier Model PB-06](#)
- [3 SAFETY INSTRUCTIONS](#)
- [4 SPECIFIC INFORMATION REGARDING R290 REFRIGERANT GAS](#)
- [5 DEHUMIDIFIER BENEFITS](#)
- [6 DEHUMIDIFIER BENEFITS](#)
- [7 FEATURES](#)
- [8 SPECIFICATIONS](#)
- [9 CONTROL PANEL](#)
  - [9.1 Indicator Lights](#)
- [10 CONTROLS](#)
- [11 Setting a Turn-Off timer:](#)
- [12 SLEEP Mode: Press the SLEEP](#)
- [13 DEFROSTING](#)
- [14 CONNECTING THE WATER HOSE FOR CONTINUOUS DRAINING](#)
- [15 REMOVING AND EMPTYING THE WATER TANK](#)
- [16 CLEANING](#)
- [17 RECYCLING & DISPOSAL](#)
- [18 Read More About This Manual & Download PDF:](#)
- [19 Documents / Resources](#)
  - [19.1 References](#)
- [20 Related Posts](#)

# ProBreeze PB-06 12L Compressor Dehumidifier Instruction Manual

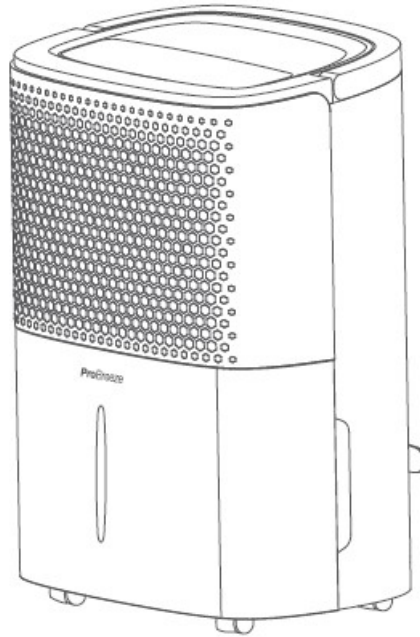

## 12L Compressor Dehumidifier Model PB-06

Thank you for choosing to purchase a product from Pro Breeze. Please read the entire manual carefully prior to first use and keep in a safe place for future reference.

### SAFETY INSTRUCTIONS



PLEASE READ AND SAVE THESE IMPORTANT SAFETY INSTRUCTIONS.

When using electrical appliances, basic safety precautions should always be followed to reduce the risk of fire, electric shock, and injury to persons, including the following:



**WARNING: TO AVOID THE RISK OF ELECTRICAL SHOCK, FIRE OR INJURY TO PEOPLE, ALWAYS TURN THE APPLIANCE OFF, UNPLUG THE POWER CORD FROM THE ELECTRICAL OUTLET AND EMPTY THE WATER TANK BEFORE HANDLING, CLEANING OR SERVICING THE APPLIANCE.**

- Use this appliance only as described in this manual. Any other use not recommended by the manufacturer may cause fire, electric shock, or injury to person.
- The appliance is not to be used by persons (including children) with reduced physical, sensory or mental capabilities, or lack of experience and knowledge, unless they have been given supervision or instruction.
- Never place anything on top of the appliance.
- Children must be supervised not to play with the appliance.
- Do not cover the appliance whilst in use.
- Do not immerse the appliance in water.
- Dispose of water collected from the appliance. This water is not drinkable
- The appliance must have a minimum 50cm clearance around all sides.
- Children of less than 3 years and pets should be kept away unless continuously supervised.

- Do not leave children alone or unattended in the area where the appliance is in use.
- Cleaning and user maintenance shall not be made by children unless continuously supervised.
- Place the appliance on a flat, stable and dry surface and always keep the appliance in an upright position. Operating the appliance in any other position could cause a hazard.
- Do not place the appliance against a wall or other appliances.
- Do not cover the appliance or restrict the air flow of the inlet or exhaust grills whilst in use.
- Do not operate the appliance with wet hands.
- Do not use this appliance near water or in the immediate surroundings of a bath, shower or a swimming pool. Never place the appliance where it may fall into a bathtub or other water container.
- Do not allow water or other liquids to run into the interior of the appliance, as this could create a fire and/or electrical hazard.
- Do not use mechanical devices to accelerate the appliances defrosting process.
- Do not place the continuous drainage hose outside when the temperature falls below 1C.
- Do not use the appliance without the air filter.
- This appliance is intended for indoor household use and similar applications. Do not use outdoors.
- Never leave the appliance unattended while in use. Always turn the appliance off and disconnected from the power supply when not in use.
- Avoid placing the power cord in areas where it can become a tripping hazard. Do not place the power cord under carpeting or cover it with rugs, runners or similar.
- To avoid a circuit overload when using this appliance, do not operate another high-wattage appliance on the same electrical circuit.
- Always plug the appliance directly into a wall socket. Avoid using extension leads where possible as they may overheat and cause a risk of fire.
- Do not use this appliance with an external programmer, timer switch or any other device which would switch the appliance on automatically unless this has already been pre-built into the appliance by the manufacturer.
- Do not pull on the power cord. Never move, carry, or hang the appliance by the power cord.
- Do not kink or wrap the power cord and plug around the appliance, as this may cause the insulation to weaken or split, particularly where it enters the appliance.
- The appliance is only to be used with the power adapter provided. Do not use other chargers or power adapters as this may damage the product and battery.
- Do not operate the appliance with the water tank removed.
- Ensure the mains cable is fully extended before use and arrange it so that it is not in contact with any part of the appliance.
- Do not operate the appliance with any safety guards removed.
- Do not attempt to repair or adjust any electrical or mechanical elements in the appliance. Doing so may be unsafe and will void your warranty.
- Ensure that the mains supply (including voltage, frequency and power) complies with the rating label of the appliance.
- Do not use the appliance near petrol, paints, flammable gases, ovens, or other heating sources.
- Never insert fingers or metal objects into the vents and openings of the appliance
- Do not operate the appliance if there are signs of damage to the appliance, power cord, or any of the accessories supplied. If the supply cord is damaged, it must be replaced by the manufacturer, its service agent or a similarly qualified person in order to avoid a hazard.

## SPECIFIC INFORMATION REGARDING R290 REFRIGERANT GAS

- The appliance must be installed, used and stored in an area that is greater than 4m<sup>2</sup>.
- This appliance contains 55g of R290 refrigerant gas.
- R290 is a refrigerant gas that complies with the European directive on the environment. Do not puncture any part of refrigerant circuit.
- Be aware R290 refrigerant is odourless and does not have the odour normally associated with natural gas and propane tanks.
- The appliance must be placed in an area without any continuous sources of ignition such as open flames, gas, or electrical appliances in operation.
- Do not puncture and do not burn.
- If the appliance is installed, operated or stored in a non-ventilated area, the room must be designed to prevent the accumulation of refrigerant leaks resulting in a risk of fire or explosion due to ignition of the refrigerant caused by electric heaters, stoves, or other sources of ignition.
- The appliance must be stored in such a way as to prevent mechanical failure.
- Individuals who operate or work on the refrigerant circuit must have the appropriate certification issued by an accredited organisation that ensures competence in handling refrigerants according to a specific evaluation recognised by associations in the industry.
- Maintenance and repairs that require the assistance of other qualified personnel must be performed under the supervision of an individual specified in the use of flammable refrigerants.



## DEHUMIDIFIER BENEFITS

For advice on the benefits of dehumidifiers and how to get the best out of your unit, visit our Advice Blog at [www.ProBreeze.com](http://www.ProBreeze.com).

## DEHUMIDIFIER BENEFITS

For advice on the benefits of dehumidifiers and how to get the best out of your unit, visit our Advice Blog at [www.ProBreeze.com](http://www.ProBreeze.com)

## FEATURES

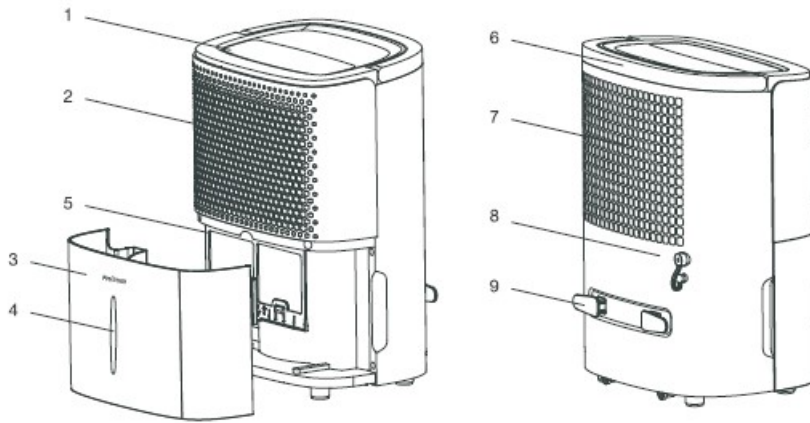

1. Control panel
2. Air inlet
3. Water tank
4. Water level indicator
5. Filter
6. Handle
7. Air outlet
8. Water hose connector
9. Wire tidy

## SPECIFICATIONS

- Collection Capacity: 12L per day at 30°C and 80% relative humidity
- Size: 21.7 x 29.6 x 43.7 cm
- Rated Voltage: 220-240V~
- Rated Frequency: 50Hz
- Rated Input Power: 200W
- Max Tank Capacity: 1.8L
- Net Weight: 10.5kg
- Operating Range: 5°C – 32°C

## CONTROL PANEL

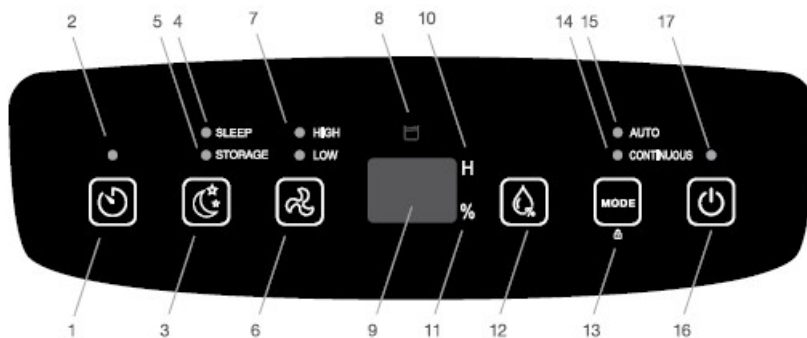

## Indicator Lights

1. Timer button
2. Timer indicator light
3. Sleep Mode / Storage Cycle button
4. Sleep indicator light
5. Storage Cycle indicator light
6. Fan Speed button
7. Fan Speed indicator lights
8. Water tank full indicator light
  1. Press the Power button to turn the dehumidifier on.
  2. Press the Timer button to activate the timer function.
  3. Press Timer button to set the desired time (1-24 hours) until Turn-On.
  4. The time digits will blink five times to confirm a timer has been set and show the remaining time till Turn-On.
  5. Select the desired settings prior to Turn-On.
9. Display panel
10. Hour indicator
11. Humidity indicator
12. Humidity set button
13. Mode / Child Lock button
14. Continuous mode indicator light
15. Auto mode indicator light
16. Power button
17. Power indicator light

## **CONTROLS**

Timer Button: Set a Turn-On or Turn-Off timer, between 1-24 hours. Setting a Turn-On timer:

1. Press the Power button to turn the dehumidifier on.
2. Press the Timer button to activate the timer function.
3. Press Timer button to set the desired time (1-24 hours) until Turn-On.
4. The time digits will blink five times to confirm a timer has been set and show the remaining time till Turn-On.
5. Select the desired settings prior to Turn-On.

Note: If no specific settings are selected the dehumidifier will run in AUTO mode.

### **Setting a Turn-Off timer:**

1. Press the Power button to turn the dehumidifier on.
2. Set the dehumidifier to the desired settings.
3. Press the Timer button to activate the timer function.
4. Press Timer button to set the desired time (1-24 hours).
5. The time digits will blink five times to confirm a timer has been set and then revert to the current room humidity.
6. To check the remaining time until Time-Off press the Timer button.

## **SLEEP Mode: Press the SLEEP**

mode / STORAGE Cycle Button to activate. In SLEEP mode the dehumidifiers humidity is set to 50% and the fan operates in low speed. If the actual room humidity is 5% greater than 50% humidity the dehumidifiers compressor will activate, and the fan will operate at low speed. If the actual room humidity is 5% less than 50% humidity the dehumidifiers compressor will stop collecting water but the fan will continue to operate at low speed.

Note: Fan speed cannot be adjusted when SLEEP mode is set.

STORAGE Cycle: Press and hold the SLEEP mode / STORAGE Cycle button for three seconds to activate. The dehumidifiers compressor stops collecting water, and the fan runs at high speed for 30 minutes followed by a further 20 minutes at low speed. This process dries the dehumidifier prior to storage.

Note: Prior to storage ALWAYS run a STORAGE cycle.

Fan Speed Button: Sets the fan speed to HIGH or LOW speed.

Humidity Button: Sets your desired humidity level between 80% – 30% humidity in 5% decrements.

Mode / Child Lock Button: Select between AUTO mode / CONTINUOUS mode / Child Lock.

AUTO Mode: In AUTO mode if the actual room humidity is 5% greater than that of the set humidity the dehumidifiers compressor will activate, and the fan will operate at the set fan speed. If the actual room humidity is 5% less than that of the set humidity the dehumidifiers compressor will stop collecting water, but the fan will continue to operate at the set fan speed.

CONTINUOUS Mode: In CONTINUOUS mode the dehumidifiers compressor and fan (at the set fan speed) will continuously operate. In this mode the fan speed is adjustable.

Child Lock: Locks the controls for child safety. Press and hold the Child Lock button for three seconds to lock and unlock. The display panel will show LC for five seconds after Child Lock is activated prior to returning to the current room humidity.

Power Button: Turns the dehumidifier ON and OFF.

## **DEFROSTING**

The unit may need defrosting in temperatures less than 16°C. This will happen automatically and last up to ten minutes. During this time, P1 will show on the display panel and the compressor will stop collecting water but the fan will continue to run at its prior setting.

Do not switch off while the unit is defrosting.

## **CONNECTING THE WATER HOSE FOR CONTINUOUS DRAINING**

For long-term use, it is recommended to connect a hose for continuous drainage. To attach the hose:

1. Remove the plug from the water hose connector located on the back of the dehumidifier.
2. Insert the hose into the water hose connector and check it is connected properly.
3. Ensure the hose end has a suitable drainage outlet (e.g. a drain or bucket).

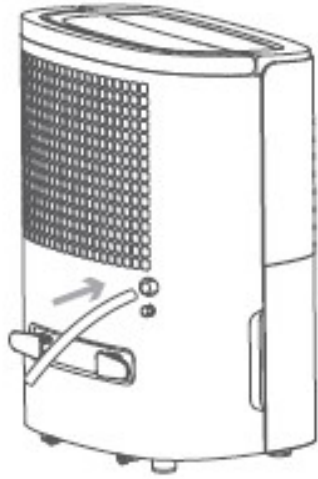

## REMOVING AND EMPTYING THE WATER TANK

When the water tank is full 10 beeps will sound; the Water Tank Full indicator light will illuminate, and the dehumidifier will pause operation to prevent the water tank from overflowing. To remove and empty the water tank:

1. Turn off the dehumidifier and unplug it from the wall socket.
2. Gently pull the water tank out from the front of the dehumidifier.
3. Empty the water tank.
4. Once empty, slot the tank back in carefully.

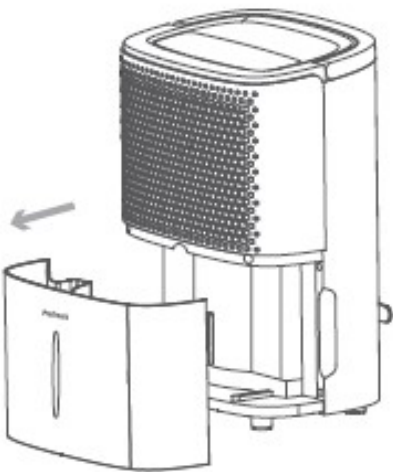

## CLEANING



**WARNING:** ALWAYS TURN THE APPLIANCE OFF, UNPLUG THE POWER CORD FROM THE ELECTRICAL OUTLET BEFORE HANDLING OR CLEANING IT.



**CAUTION:** DO NOT ALLOW WATER OR OTHER LIQUIDS TO RUN INTO THE INTERIOR OF THE APPLIANCE, AS THIS COULD CREATE A FIRE AND/OR ELECTRICAL HAZARD.





- Do not attempt to clean the appliance in any other way than that detailed by the manufacturer.
- Always empty the water tank, clean and dry the appliance when not in use to prevent mould.
- Store in a clean, dry place away from direct sunlight. Place out of reach of children.
- Ensure the appliance and water tank are clean and dry before storage

Filter Cleaning: The filter is located behind the air outlet on the front of the dehumidifier.  
To access the filter:

1. Turn off the dehumidifier and unplug it from the wall socket.
2. Remove the water tank.
3. Pull down on the filter tab and remove the filter.
4. Use a vacuum cleaner and damp cloth to clean the filter of any dust and particles.
5. Put the filter back and replace the water tank. Ensure the hose end has a suitable drainage outlet (e.g. a drain or bucket).

The filter should be cleaned every two weeks.

## RECYCLING & DISPOSAL

  The packaging of your new product has a recycle mark on it. Please dispose of it as recycled paper. Waste electrical products should not be disposed of with general household waste. This is to prevent the possible harm to the environment and human well-being. Contact your local council or government for information regarding the collection schemes in your area.

***Read More About This Manual & Download PDF:***

## Documents / Resources

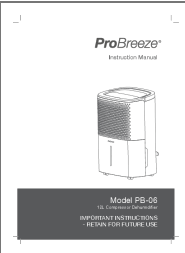
	<p><a href="#">ProBreeze PB-06 12L Compressor Dehumidifier</a> [pdf] Instruction Manual PB-06, 12L Compressor Dehumidifier, PB-06 12L Compressor Dehumidifier</p>
---	---

## References

- [PB Pro Breeze | Free Delivery | Dehumidifiers, Air Cooling & Heaters](#)