



PLANET

Layer 3 Gigabit/10 Gigabit Stackable Managed Switch

SGS-6310 Series

Quick Installation Guide

Contents [[hide](#)]

- [1 Package Contents](#)
- [2 Switch Management](#)
- [3 Requirements](#)
- [4 Terminal Setup](#)
- [5 Starting Web Management](#)
- [6 LED Indicators](#)
- [7 Recovering Back to Default Configuration](#)
- [8 Customer Support](#)
- [9 Documents / Resources](#)
 - [9.1 References](#)

Package Contents

Thank you for purchasing Layer 3 Gigabit/10 Gigabit Stackable Managed Switch, SGS-6310-Series.

Unless otherwise specified, the “Managed Switch” mentioned in this Quick Installation Guide refers to the SGS-6310-Series, as detailed in the following list.

Model	Description
SGS-6310-16S8C4XR	L3 16-Port 100/1000X SFP + 8-Port Gigabit TP/SFP + 4-Port 10G SFP+ Stackable Managed Switch (Dual 100~240V AC)
SGS-6310-24T4X	L3 24-Port 10/100/1000T + 4-Port 10G SFP+ Stackable Managed Switch
SGS-6310-24P4X	L3 24-Port 10/100/1000T 802.3at PoE + 4-Port 10G SFP+ Stackable Managed Switch
SGS-6310-48T6X	L3 48-Port 10/100/1000T + 6-Port 10G SFP+ Stackable Managed Switch
SGS-6310-48P6XR	L3 48-Port 10/100/1000T 802.3at PoE + 6-Port 10G SFP+ Stackable Managed Switch with 55V DC Redundant Power
SGS-6310-8P4X	L3 8-Port 10/100/1000T 802.3at PoE + 4-Port 10G SFP+ Stackable Managed Switch

Open the box of the Managed Switch and carefully unpack it. The box should contain the following items:

	SGS-6310-16S8C4XR	SGS-6310-24T4X	SGS-6310-4P4X	SGS-6310-48T6X	SGS-6310-48P6XR	SGS-6310-8P4X
Quick Installation Guide sheet	■	■	■	■	■	■
DB9 to RJ45 Interface RS232 Console Cable	■	■	■	■	■	■

Rack-mount Accessory Kit	■	■	■	■	■	■
AC Power Cord	2	2	1	2	1	1
SFP Dust Cap	28	4	4	6	6	4
Rubber Feet	4	4	4	4	4	4

If any item is found missing or damaged, please contact your local reseller for replacement.

Switch Management

To set up the Managed Switch, the user needs to configure the Managed Switch for network management. The Managed Switch provides two management options: Out-of-Band Management and In-Band Management.

- **Out-of-Band Management**

Out-of-band management is the management through console interface.

Generally, the user will use out-of-band management for the initial switch configuration, or when in-band management is not available.

- **In-Band Management**

In-band management refers to the management by logging in to the Managed Switch using Telnet or HTTP, or using SNMP management software to configure the Managed Switch. In-band management enables the management of the Managed Switch to attach some devices to the Switch. The following procedures are required to enable in-band management:

1. Log on to console
2. Assign/Configure IP address
3. Create a remote login account
4. Enable HTTP or Telnet server on the Managed Switch

In case in-band management fails due to Managed Switch configuration changes, out-of-band management can be used for configuring and managing the Managed Switch.



The Managed Switch is shipped with VLAN1 interface IP address 192.168.0.254/24 assigned by default. User can assign another IP address to the Managed Switch via the console interface to be able to remotely access the Managed Switch through Telnet or HTTP.

Requirements

- Workstations running Windows 10/11, MAC OS 10.16 or later, Linux, UNIX, or other platforms are compatible with TCP/IP Protocols.
- Workstations are installed with Ethernet NIC (Network Interface Card)
- Serial Port Connection (Terminal)
 - ▷ The above Workstations come with COM Port (DB9) or USB-to-RS232 converter.
 - ▷ The above Workstations have been installed with terminal emulator, such as Hyper Terminal included in Windows 10/11, putty or tera term.
 - ▷ Serial cable — one end is attached to the RS232 serial port, while the other end to the console port of the Managed Switch.
- Management Port Connection
 - ▷ Network cables — Use standard network (UTP) cables with RJ45 connectors.
 - ▷ The above PC is installed with Web browser.



It is recommended to use Google Chrome or other advanced browsers to access the Managed Switch. If the Web interface of the Managed Switch is not accessible, please turn off the anti-virus software or firewall and then try it again.

• Desk Placement and Heat Dissipation

When using the SGS-6310 series on a desk, be sure to attach four foot pads to the bottom of the device to increase airflow for better heat dissipation. Please refer to the illustration below for proper placement.

Attention!

Be sure to attach the rubber feet to the bottom of the switch before use

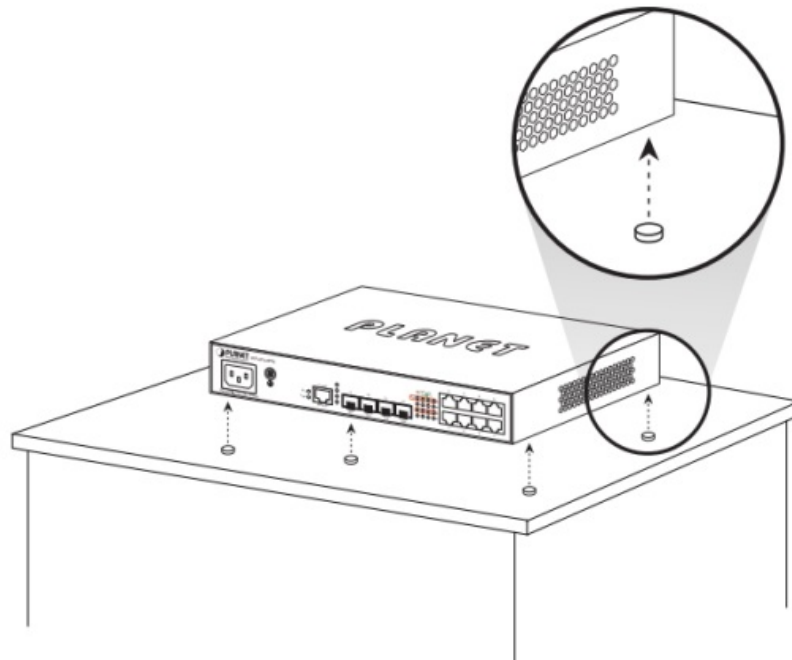

Terminal Setup

To configure the system, connect a serial cable to a COM port on a PC or notebook computer and to serial (console) port of the Managed Switch. The console port of the Managed Switch is DCE already, so that you can connect the console port directly through PC without the need of Null Modem.

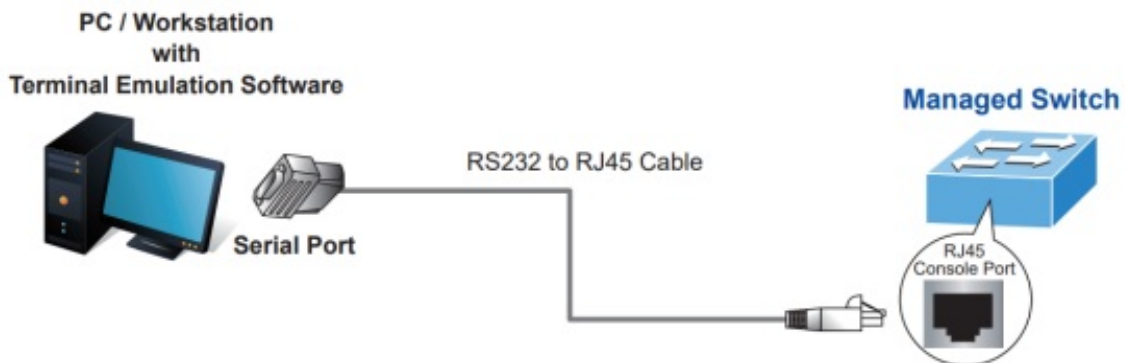

Figure 4-1: Managed Switch Console Connectivity

A terminal program is required to make the software connection to the Managed Switch. Tera Term program may be a good choice. The Tera Term can be accessed from the Start menu.

1. Click START menu, then Programs, and then Tera Term.
2. When the following screen appears, make sure that the COM port should be configured as:

- Baud: 9600
- Parity: None
- Data bits: 8 .
- Stop bits: 1
- Flow control: None

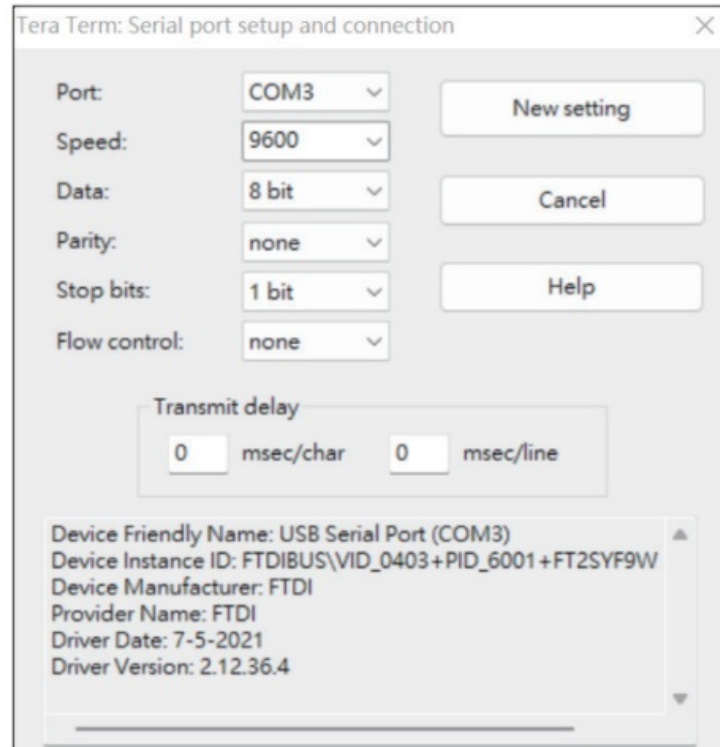

Figure 4-2: Tera Term COM Port Configuration

4.1 Logging on to the Console

Once the terminal is connected to the device, power on the Managed Switch, and the terminal will display “running testing procedures”.

Then, the following message asks for the login user name and password. The factory default user name and password are shown below on the login screen:

Username: admin

Password: sw + the last 6 characters of the MAC ID in lowercase

Find the MAC ID on your device label. The default password is “sw” followed by the last six lowercase characters of the MAC ID.

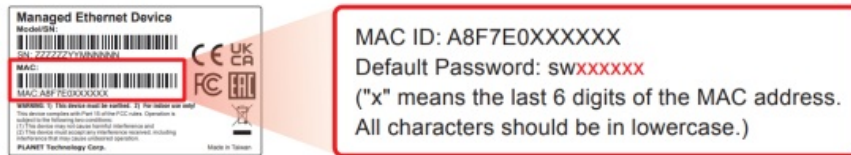

Figure 4-3: MAC ID Label

Enter the default username and password, then set a new password according to the rule-based prompt and confirm it.

```
Username: admin
Password: *****

Please input a new password:*****
Please input the new password AGAIN:*****

Switch>Jan 1 00:10:28 User admin logged in from on console 0
Switch>enable
Switch#Jan 1 00:10:34 User admin enter privilege mode from console 0, level = 15
Switch#
```

Figure 4-4: Managed Switch Console Login Screen

The user can now enter commands to manage the Switch. For a detailed description of the commands, please refer to the following chapters.



Accept command in lowercase or uppercase letter under console interface.

4.2 Configuring IP Address

The IP address configuration commands for VLAN1 interface are listed below.

Before using in-band management, the Managed Switch must be configured with an IP address by out-of-band management (i.e. console mode). The configuration commands are as follows:

```
Switch>enable
```

```
Switch# config
```

```
Switch_config# interface vlan 1
```

```
Switch_config_v1# ip address 192.168.1.254 255.255.255.0
```

The previous command would apply the following settings for the Managed Switch.

IPv4 Address: 192.168.1.254

Subnet Mask: 255.255.255.0

```

Switch>
Switch>enable
Switch#Jan 1 01:52:14 User admin enter privilege mode from
Switch#config
Switch_config#interface vlan 1
Switch_config_vl#ip address 192.168.1.254 255.255.255.0
Switch_config_vl#

```

Figure 4-5: Configuring IPv4 Address Screen

To check the current IP address or modify a new IP address for the Managed Switch, please use the procedures as follows:

■ Show the current IP address

1. On “Switch#” prompt, enter “show ip interface brief”.
2. The screen displays the current IP address, subnet mask and gateway as shown in Figure 4-6.

```

Switch#config
Switch_config#interface vlan1
Switch_config_vl#ip address 192.168.1.254 255.255.255.0
Switch_config_vl#
Switch_config_vl#
Switch_config_vl#
Switch_config_vl#exit
Switch_config#show ip interface brief
Interface          IP-Address      Method Protocol-Status
Null0              unassigned     manual up
VLAN1              192.168.1.254  manual up
Switch_config#

```

Figure 4-6: Showing IP Information Screen

If the IP is successfully configured, the Managed Switch will apply the new IP address setting immediately. You can access the Web interface of Managed Switch through the new IP address.



If you are not familiar with console command or the related parameter, enter “help” anytime in console to get the help description.

4.3 Configuring 1000BASE-X on a 10G SFP+ Port

The Managed Switch supports both 1000BASE-X and 10GBASE-X SFP transceivers by manual setting and the default SFP+ port speed is set in the fiber auto mode, so the end-user can plug the transceiver directly.

In another example, the end-user has to force the fiber connection with 1000BASE-X SFP transceiver in the tgigaethernet 0/1. The following command configuration is

required:

```
Switch#config  
Switch_config#interface TGigaEthernet0/1  
Switch_config_tg0/1#no fiber-auto-config  
Switch_config_tg0/1#speed 1000  
Switch_config_tg0/1#exit
```

Figure 4-7: Setting 1000BASE-X for 10G SFP+ Screen

4.4 Changing Password

The default password of the switch is “admin”. For security reason, it is recommended to change password and the following command configuration is required:

```
Switch #config  
Switch_config#username admin password planet2022  
Switch_config#
```

Figure 4-8: Changing Password Interface Screen

4.5 Saving the Configuration

In Managed Switch, the running configuration file stores in the RAM. In the current version, the running configuration sequence running-config can be saved from the RAM to FLASH by write command, so that the running configuration sequence becomes the start-up configuration file, which is called configuration save.

```
Switch#write  
Switch#write  
Saving current configuration...  
OK!  
Switch#Jan 2 00:56:04 /startup-config is wrote, TID:85bd29c0
```

Figure 4-9: Write Screen

Starting Web Management

The Managed Switch provides a built-in browser interface. You can manage it remotely by having a remote host with Web browser, such as Google Chrome, Mozilla Firefox, Google Chrome or Apple Safari.



Figure 5-1: IP Management Diagram

The following shows how to start up the Web Management of the Managed Switch. Please note the Managed Switch is configured through an Ethernet connection. Please make sure the manager PC must be set to the same IP subnet address.

5.1 Logging in to the Managed Switch from Copper Ports

1. Use Google Chrome or above Web browser and enter IP address <https://192.168.0.254> (that you have just set in console) to access the Web interface.

2. When the following dialog box appears, please enter the default user name and password. Refer to Section 4.1 to determine your initial login password.

Default IP Address: 192.168.0.254

Default User Name: admin

Default Password: sw + the last 6 characters of the MAC ID in lowercase

The image shows a web login interface for a Planet Managed Switch. At the top left is the Planet logo with the text "PLANET Networking & Communication". Below the logo, the device model "SGS-6310-48T6X" is displayed. There are two input fields: "Username*" with the value "admin" and "Password*" with a masked password of seven dots. A blue "Login" button is positioned below the password field.

Figure 5-2: Web Login Screen

After logging in, you will be prompted to change the initial password to a permanent one.

The image shows a "Create a New Password" screen. At the top, a red banner reads "You need to change the password for the first login". Below this, there are four input fields: "Username*" with the value "admin", "New Password*", "Password strength*", and "Verify New Password*". An "Apply" button is located at the bottom center of the form.

Figure 5-3: Create a New Password

3. After entering the password, the main screen appears as shown in Figure 5-4.



Figure 5-4: Web Main Screen of Managed Switch

4. The Switch Menu on the left of the Web page lets you access all the commands and statistics the Switch provides.

Now, you can use the Web management interface to continue the switch management or manage the Managed Switch by console interface. Please refer to the user manual for more.

5.2 Saving Configuration via the Web

The configuration area is to show the content that is selected in the navigation area.

The configuration area always contains one or more buttons, such as “Refresh”, “Apply” and “Reset”.

The “Apply” button indicates applying the modified configuration to the device. The application of the configuration does not mean that the configuration is saved in the configuration file.

To save the configuration, you have to click “Save All” on the top control bar.

“Save All” function is equivalent to the execution of the write command.



Figure 5-5: Save Configuration

LED Indicators

6.1 SGS-6310-24T4X

- System

LED	Color	Function
PWR	Green	Lights to indicate that the Switch has power.
	Off	Power is off.
SYS	Green	Slow blinks to indicate the system is normally starting up.

- Interfaces

LED	Color	Function	
LNK/ACT	Green	Lights	Indicating the port is running and the connection is successfully established.

		Blinks	Indicating that the switch is actively sending or receiving data over that port.
--	--	--------	--

- **10G Status LED**

LED	Color	Function	
LNK/ACT (Ports 25-28)	Green	Lights	Indicating the port is running and the connection is successfully established.
		Blinks	Indicating that the switch is actively sending or receiving data over that port.

6.2 SGS-6310-24P4X

- **System**

LED	Color	Function
PWR	Green	Lights to indicate that the Switch has power.
	Off	Power is off.
SYS	Green	Slow blinks to indicate the system is normally starting up.

- **Interfaces**

LED	Color	Function	
1000 LNK/ACT	Green	Lights	Indicating the port is running at 1000Mbps and successfully established.
		Blinks	Indicating that the switch is actively sending or receiving data over that port.

10/100 LNK/ACT	Amber	Lights	Indicating the port is running at 10/100Mbps and successfully established.
		Blinks	Indicating that the switch is actively sending or receiving data over that port.
802.3at PoE-In-Use	Amber	Lights	PD is connected and PoE power supply is normal.
		Off	PD is not connected or PoE power supply is not provided.

10G Status LED

LED	Color	Function	
10G LNK/ACT	Amber	Lights	Indicating the port is running at 10Gbps and successfully established.
		Blinks	Indicating that the switch is actively sending or receiving data over that port.
1000 LNK/ACT	Green	Lights	Indicating the port is running at 1000Mbps and successfully established.
		Blinks	Indicating that the switch is actively sending or receiving data over that port.

6.3 SGS-6310-16S8C4XR

System

LED	Color	Function
PWR	Green	Lights to indicate that the Switch has power.
	Off	Power is off.

SYS	Green	Slow blinks to indicate the system is normally starting up.
-----	-------	---

Interfaces

LED	Color	Function	
LNK/ACT	Green	Lights	Indicating the port is running and the connection is successfully established.
		Blinks	Indicating that the switch is actively sending or receiving data over that port.

10G Status LED

LED	Color	Function	
LNK/ACT (Ports 25-28)	Green	Lights	Indicating the port is running and the connection is successfully established.
		Blinks	Indicating that the switch is actively sending or receiving data over that port.

6.4 SGS-6310-48T6X

System

LED	Color	Function	
PWR	Green	Lights to indicate that the Switch has power.	
	Off	Power is off.	
SYS	Green	Slow blinks to indicate the system is normally starting up.	

Interfaces

LED	Color	Function	
LNK/ACT	Green	Lights	Indicating the port is running and the connection is successfully established.
		Blinks	Indicating that the switch is actively sending or receiving data over that port.

10G Status LED

LED	Color	Function	
LNK/ACT (TG1-TG6)	Green	Lights	Indicating the port is running and the connection is successfully established.
		Blinks	Indicating that the switch is actively sending or receiving data over that port.

6.5 SGS-6310-48P6XR

LED Mode: When you press the LED Mode button, the LNK/ACT will change to PoE device detect mode.

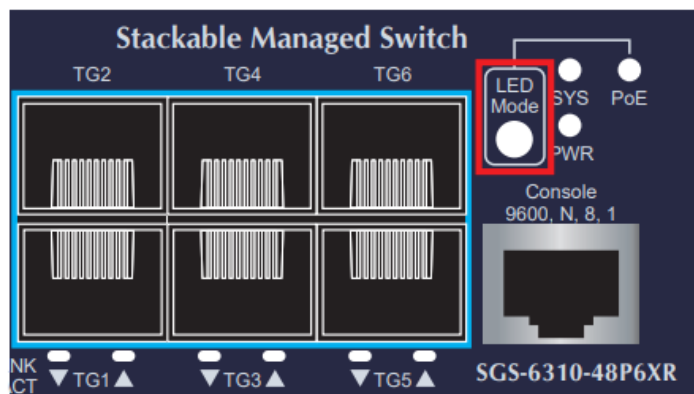

System

LED	Color	Function	
		Lights	Lights to indicate that the Switch has power.

PWR	Green	Off	Power is off.
SYS	Green	Slow b links	To indicate the system is normally starting up.
PoE	Green	Lights	To indicate ports 1 to 48 LEDs are in PoE device detect mode.
		Off	To indicate ports 1 to 48 LEDs are in LNK/ACT mode.

Interfaces

LED	Color	Function	
LNK/ACT	Green	Lights	Indicating the port is running and the connection is successfully established.
		Blinks	Indicating that the switch is actively sending or receiving data over that port.
802.3at PoE-in-Use	Green	Lights	PD is connected and PoE power supply is normal.
		Off	PD is not connected or PoE power supply is not provided.

10G Status LED

LED	Color	Function	
LNK/ACT (TG1-TG6)	Green	Lights	Indicating the port is running and the connection is successfully established.
		Blinks	Indicating that the switch is actively sending or receiving data over that port.

6.6 SGS-6310-8P4X

System

LED	Color	Function
PWR	Green	Lights to indicate that the Switch has power.
	Off	Power is off.
SYS	Green	Slow blinks to indicate the system is normally starting up.

Gigabit Copper Port Interfaces

LED	Color	Function	
10/100/1000 LNK/ACT	Green	Lights	Indicating the port is running at 10/100/1000Mbps and successfully established.
		Blinks	Indicating that the switch is actively sending or receiving data over that port.

PoE-in-Use

LED	Color	Function	
PoE-in-Use	Amber	Lights	Indicates that the PoE function is active, and power is being supplied to the connected device.

10G SFP+ Port Status LED

LED	Color	Function	
1G/10G LNK/ACT	Green	Lights	Indicating the port is running at 1000Mbps/10Gbps and successfully established.
		Blinks	Indicating that the switch is actively sending or receiving data over that port.

Recovering Back to Default Configuration

When you forget the login password, please use the following method to reset the device to default and reset the password.

Press the hardware-based reset button

The SGS-6310-24P4X models has a reset button on the chassis. Press the hardware-based reset button for about 5 seconds. After the SGS-6310-24P4X has reset to default, you can log in to the management web interface. Then, follow the method in section 5.1 to reset the password.

Use a console cable to access the CLI

Please use a console cable to connect to the switch, reboot the switch, and when the screen displays “SDRAM Fast Test...PASS,” press “Ctrl+P” to enter Monitor mode.

Please enter “del startup-config” again and follow the steps shown in the image to reset to default. Then, follow the method in section 5.1 to reset the password.

```
monitor#del startup-config
this file will be erased,are you sure?(y/n)y
monitor#reboot
Do you want to reboot the Switch(y/n)?y
Please wait...
```

Customer Support

Thank you for purchasing PLANET products. You can browse our online FAQ resource at the PLANET Web site first to check if it could solve your issue. If you need more support information, please contact PLANET support team.

PLANET online FAQs: <https://planet.com.tw/en/support/faq>

Support team mail address: support@planet.com.tw

SGS-6310-Series User's Manual

<https://www.planet.com.tw/en/support/downloads?&method=keyword&keyword=SGS-63108&view=23#list>



Copyright © PLANET Technology Corp. 2025.

Contents are subject to revision without prior notice.

PLANET is a registered trademark of PLANET Technology Corp.

All other trademarks belong to their respective owners.

Documents / Resources

	<p>PLANET SGS-6310-Series Layer 3 Gigabit 10 Stackable Managed Switch [pdf] Installation Guide</p> <p>SGS-6310-Series, SGS-6310-Series Layer 3 Gigabit 10 Stackable Managed Switch, Layer 3 Gigabit 10 Stackable Managed Switch, Gigabit 10 Stackable Managed Switch, Stackable Managed Switch, Managed Switch</p>
--	--

References

- [User Manual](#)

PLANET

Gigabit 10 Stackable Managed Switch, Layer 3 Gigabit 10 Stackable Managed Switch, Managed Switch, PLANET, SGS-6310 Series, SGS-6310-Series Layer 3 Gigabit 10 Stackable Managed Switch, Stackable Managed Switch

Leave a comment

Your email address will not be published. Required fields are marked *

Comment *

Name

Email

Website

Save my name, email, and website in this browser for the next time I comment.

Post Comment

Search:

e.g. whirlpool wrf535swhz

Search

[Manuals+](#) | [Upload](#) | [Deep Search](#) | [Privacy Policy](#) | [@manuals.plus](#) | [YouTube](#)

This website is an independent publication and is neither affiliated with nor endorsed by any of the trademark owners. The "Bluetooth®" word mark and logos are registered trademarks owned by Bluetooth SIG, Inc. The "Wi-Fi®" word mark and logos are registered trademarks owned by the Wi-Fi Alliance. Any use of these marks on this website does not imply any affiliation with or endorsement.