



PANDUIT MP200 Handheld Mobile Printer User Guide

[Home](#) » [PANDUIT](#) » PANDUIT MP200 Handheld Mobile Printer User Guide 

Contents

- [1 PANDUIT MP200 Handheld Mobile Printer](#)
- [2 MP200 Printer and Accessories](#)
- [3 MP200 Label Cassettes](#)
- [4 Label Cassette Types](#)
- [5 Getting Started](#)
- [6 MP200 Display](#)
- [7 MP200 Keypad Functions](#)
- [8 Label Modes](#)
- [9 HOW TO: Serialization](#)
- [10 Symbols](#)
- [11 Barcodes](#)
- [12 Print from Easy-Mark Plus Software](#)
- [13 Other Functions](#)
- [14 Setup Menu](#)
- [15 Additional Support](#)
- [16 Global Customer Service](#)
- [17 Documents / Resources](#)
 - [17.1 References](#)
- [18 Related Posts](#)

PANDUIT[®]

PANDUIT MP200 Handheld Mobile Printer



MP200 Printer and Accessories

Part No.	Description
MP200	Includes MP200 printer, 1 cassette of T100X000VPM-BK.
MP200-KIT	Includes MP200 printer, 1 cassette of T100X000VPM-BK, hard carrying case, Li- Ion rechargeable battery pack, magnetic attachments, USB cable, and power adapter (MP-ACS-1). For use in North America
MP200/E-KIT	Includes MP200 printer, 1 cassette of T100X000VPM-BK, hard carrying case, Li- Ion rechargeable battery pack, magnetic attachments, USB cable, power adapter (M P- ACS-1) and international power cord(s). For use outside of North America
MP-ACS-1	120-240 VAC universal power adapter module with power cord for North America.
MP-BATT	Replacement Li-Ion rechargeable battery pack
MP200-CASE	Replacement hard carrying case

MP200 Label Cassettes

- Continuous label materials:
- Self-laminating Vinyl Tape, Heat Shrink Tubing
- Nylon Cloth Tape, Polyolefin Tape
- Colored Vinyl Tape, Clear Polyester Tape
- Magnetic Tape
- Compatible for use with Panduit MP Cassette Continuous Label Material up to 1" wide

Label Cassette Types

Label Material	Example Part No.	Typical Application
Self-Laminating Vinyl Tape	S000X100VAM	Wire/Cable Marking
Heat Shrink Tubing	H000X044H1M	Wire/Cable Marking
Nylon Cloth Tape	T100X000C1M-BK	Wire/Cable Marking
Polyolefin Tape	T038X000FJM-BK	Terminal Block Labeling
Colored Vinyl Tape	T100X000VPM-BK	Safety/Facility and General Identification
Clear Polyester Tape	T100X000YKC-BK	Safety/Facility and General Identification
Magnetic Tape	T100X000MXM-BK	Safety/Facility and General Identification

Getting Started

MP200-KIT Included Items



MP200 Printer

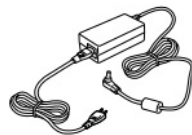

Power Supply



Battery Pack

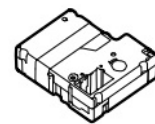

Label Cassette



USB Cable



Magnetic Attachment



Documents

Install Lion battery

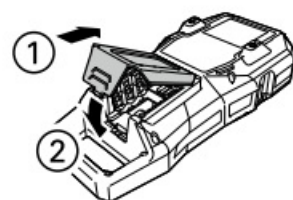
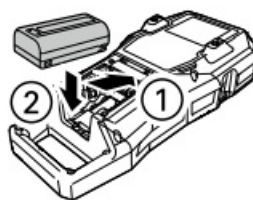
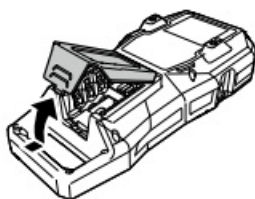

Charge Lion battery

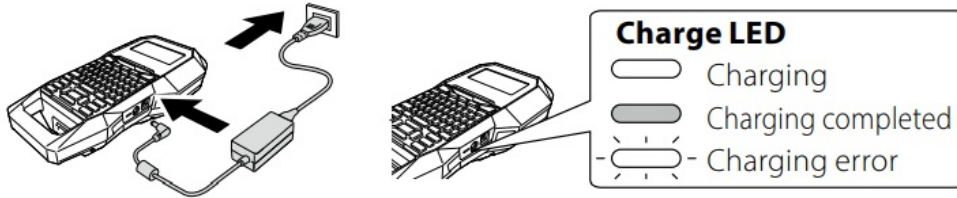

Install label cassette

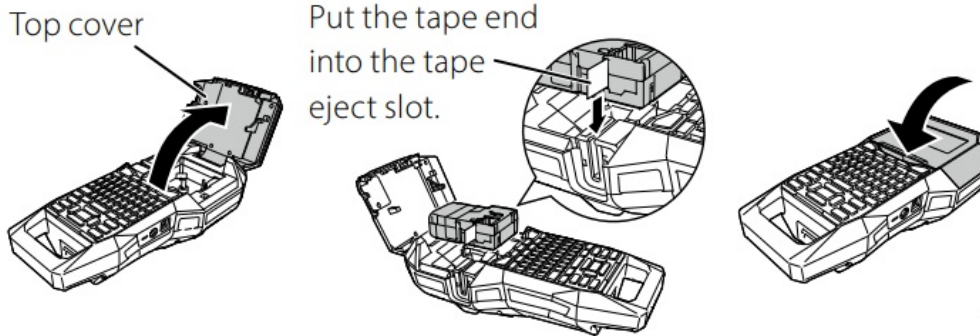

MP200 Display

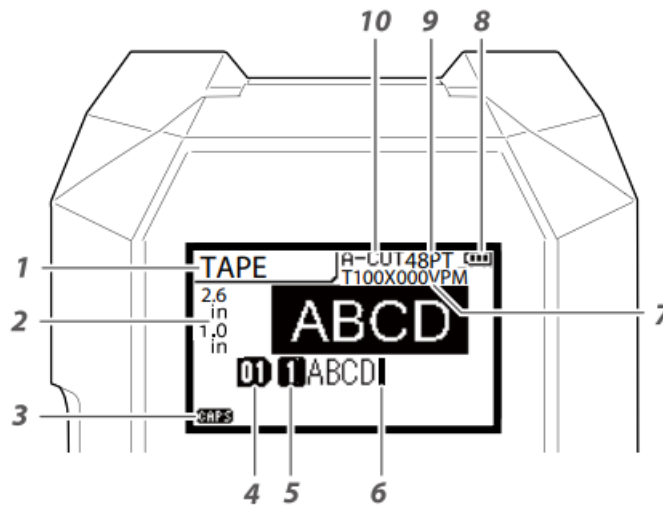

1. Label Mode
2. Current label length & width
3. CAPS Lock on
4. Page Number
5. Line Number
6. Cursor
7. Label Part number
8. Battery Life
9. Font Size
10. Cutter Setting

MP200 Keypad Functions

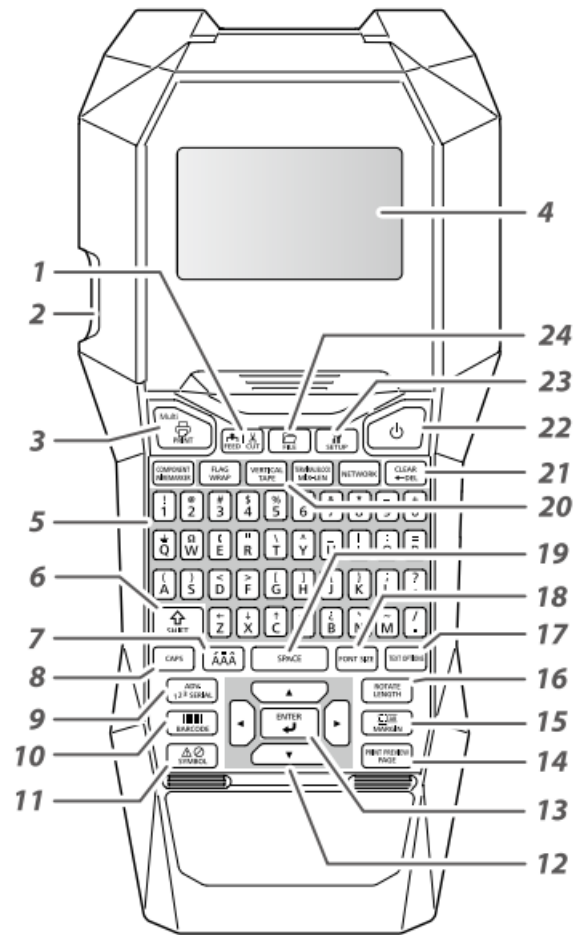

1. Feed and cut the label material
2. Label exit slot
3. Print a label
4. Display Screen
5. Number and letter keys
6. Shift/secondary functions
7. Enter a character with an accent
8. CAPS lock
9. Create a serialization
10. Create a barcode
11. Create a symbol
12. Directional arrow keys
13. Enter key
14. Add a page/print preview
15. Set label margins
16. Set tape length/rotate text
17. Text options key
18. Change font size
19. Space bar
20. Label mode keys
21. Delete/Clear key
22. Power on/off

- 23. Setup menu key
- 24. File save and recall

Label Modes

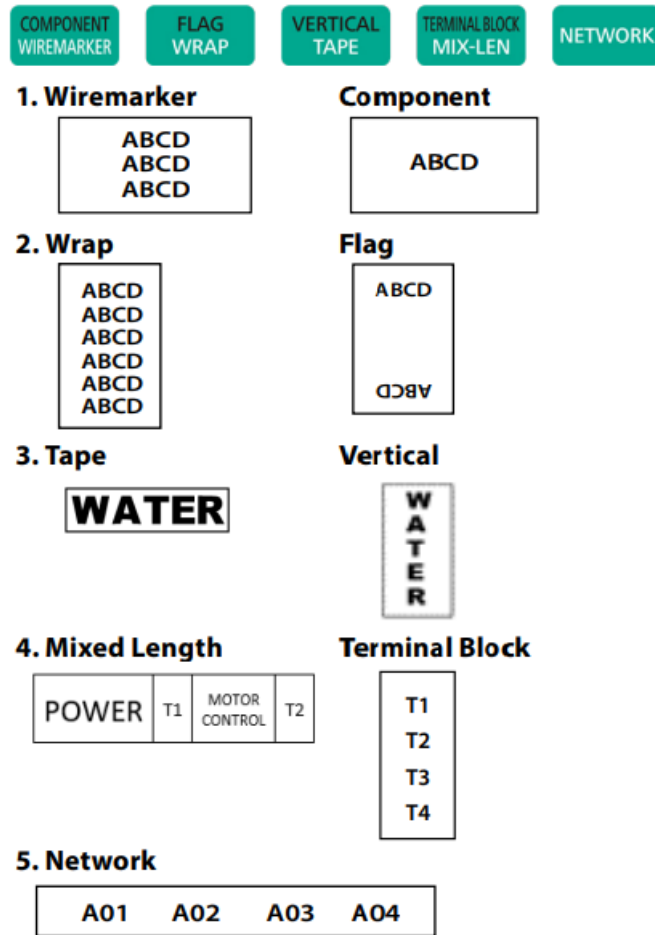

HOW TO: Serialization



1. Type "1A-A"
2. Press the SERIAL key
3. Enter a start value of 01, end value of 02, and increment value of 1
4. Press ENTER
5. Press PRINT

Example using S000X100VAM, self-laminating wire/cable markers:

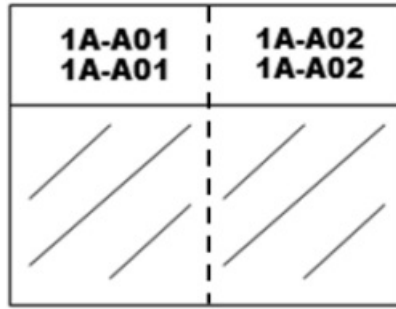

Symbols



1. Press the SYMBOL key
2. Select the symbol group named WARNING
3. Select the symbol on the first row
4. Press ENTER
5. Press SPACE
6. Type "CAUTION"
7. Press PRINT

Example using T100X000VXM-BK, black on yellow continuous vinyl tape:

Over 20 categories of symbols for electrical, network, audio visual, laboratory, arc flash, PPE, Prohibition, arrows, and more.



Hundreds of individual images included.

Barcodes

Code 39

1. Press the BARCODE key
2. Scroll to CODE 39 and press ENTER
3. Select Medium Width
4. Select 2.5 Ratio
5. Select check digit OFF
6. Type text ABC
7. Press ENTER
8. Press PRINT



QR Code

1. Press the BARCODE key
2. Scroll to QR CODE and press ENTER
3. Select Symbol Size
4. Select 7% ECC Level
5. Type text WWW.PANDUIT.COM
6. Press ENTER
7. Press PRINT



9 different barcode styles included

Print from Easy-Mark Plus Software

- Connect the MP200 printer to a computer with USB cable.
- Print from Easy-Mark Plus Labeling Software. Easy-Mark Plus is sold separately and includes MP200 driver.
- Easy-Mark Plus on disc: EMPLUS-CD
- Easy-Mark Plus on USB flash drive: EMPLUS-2GO
- Easy-Mark downloadable version: EMPLUS-DL

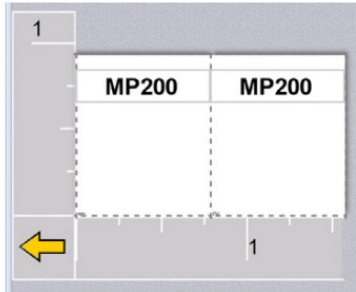

Other Functions

- PRINT – Print labels
- MULTI – Adjust print options, print copies
- FEED | CUT – Feeds label material without printing. Cuts label after feeding.
- CLEAR – Clear screen, remove formatting
- FILE – Save or recall label files
- FONT SIZE – Change the character size
- TEXT OPTIONS – Change the font styling
- MARGIN – Change the label margin
- LENGTH – Adjust the label length
- ROTATE – Rotate the text
- PAGE – Add a new page to a label design
- PRINT PREVIEW – View the label before printing

Setup Menu

- Auto Cut – Turn the Automatic Cut function ON or OFF. If Auto Cut is ON, then select Half Cut ON or OFF. Half Cut cuts through the label but not the liner.
- Print Density – Raise or lower the print density/darkness of print
- Drop Stop – Set the drop stop function to ON or OFF. Drop Stop pauses printing until the cut label has been removed from printer exit.
- Backlight – Turn backlight function ON or OFF
- Language – Select the preferred language.
13 languages are available: Dansk, Deutsch, English, Español, Français, Italiano, Nederlands, Norsk, Português – BR, Português – EU, Suomi, Svenska, Türkçe
- Inch:cm – Change the unit of measure between inches and centimeters.
- Version – Display the current operating system version number

Additional Support

Visit www.panduit.com

Free Downloads

Path: Support / Download Center / Software Firmware Printers

- Detailed Operator's Manual
- Replacement Quick Reference Card
- Product Bulletin
- Product specification and safety information.

Warranty Registration

Path: Support / Product Registration

Related Products

- MP Label Cassettes
- MP75 Printer
- MP100 Printer
- MP300 Printer
- Mobile Labeling Apps for Android and iOS
- Easy-Mark Plus Labeling Software

Note: Please refer to the instruction label in cassette compartment for the printer head cleaning.

Global Customer Service

- CS@PANDUIT.COM
- U.S. and Canada: 800-777-3300
- Europe, Middle East, and Africa: 44.20.8601.7200
- Latin America: 52.33.3777.6000
- Asia Pacific: 65.6305.7575

Panduit Technical Support

- GA-TECHSUPPORT@PANDUIT.COM
- U.S. and Canada: 1-866-871-4571
- Europe: 31.546.580.452
- Latin America: 52.33.3777.6000
- Asia Pacific: 65.6379.6700

Part Number: MP200-QRC-EN, Rev. 0.0 DWG Number: 00818EBA

Documents / Resources

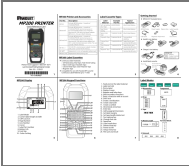

[PANDUIT MP200 Handheld Mobile Printer](#) [pdf] User Guide
MP200, Handheld Mobile Printer, Mobile Printer, Handheld Printer, Printer, MP200

References

- [P Panduit | Network Infrastructure and Industrial Electrical Wiring](#)

Manuals+