



MoseHouse WiFi Switch Module MS-104 Instruction Manual

[Home](#) » [MoseHouse](#) » MoseHouse WiFi Switch Module MS-104 Instruction Manual

Contents [[hide](#)]

[1 MoseHouse WiFi Switch Module MS-104 Instruction Manual](#)

- [1.1 Mounting Clip](#)
- [1.2 INSTALLATION](#)
- [1.3 TECHNICAL SPECIFICATIONS](#)
- [1.4 WIRING DIAGRAM](#)
- [1.5 MANUAL OVERRIDE](#)

[2 Documents / Resources](#)

[3 Related Posts](#)

MoseHouse WiFi Switch Module MS-104 Instruction Manual

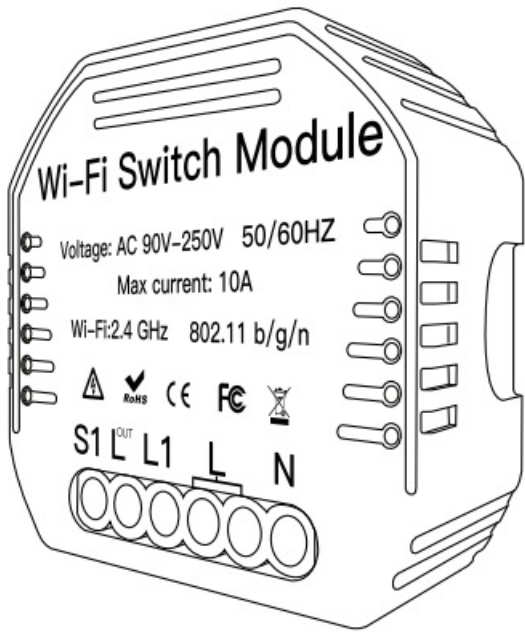

Mounting Clip

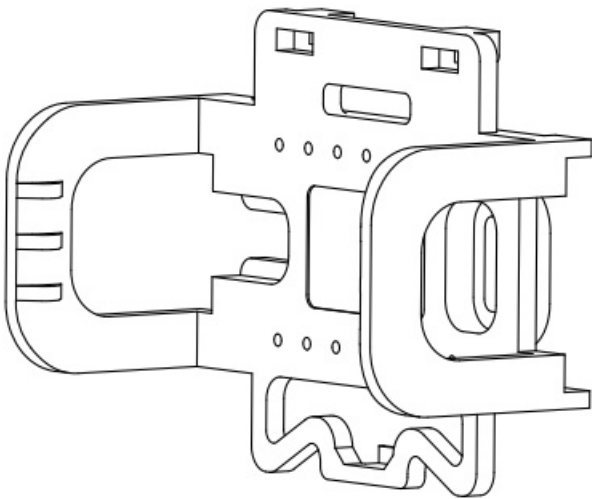

Global international operation Whenever & Wherever You are, All-in-one Mobile App

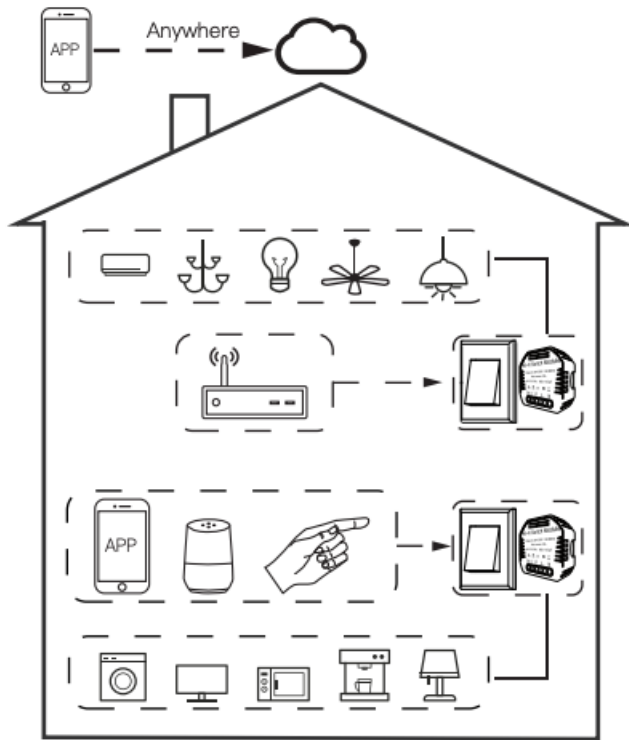
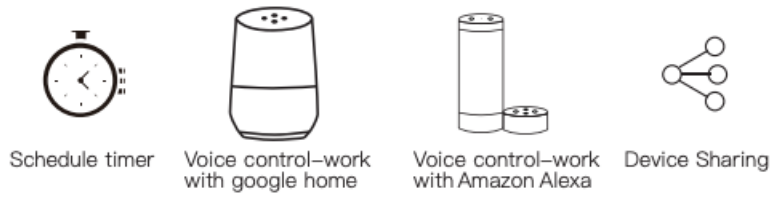

Inhouse local operation

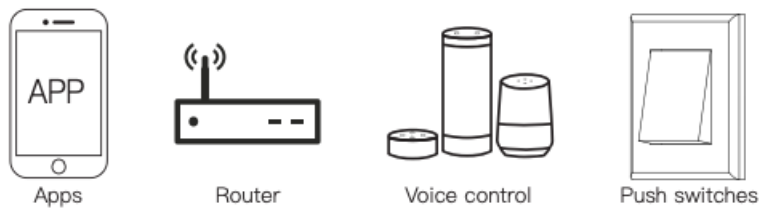

INSTALLATION

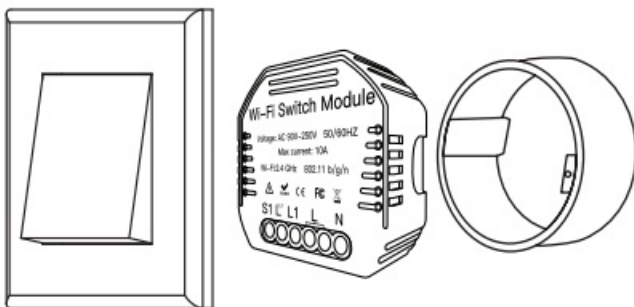

Warnings:

1. Installation must be carried out by a qualified electrician in accordance with local regulations.
2. Keep the device out of reach of children.

3. Keep the device away from water , damp or hot environment.
4. Install the device away from strong signal sources such as microwave oven that may cause signal interruption resulted to abnormal operation of the device.
5. Obstruction by concrete wall or metallic materials may reduce the effective operation range of the device and should be avoided.
6. Do NOT attempt to disassemble, repair or modify the device.

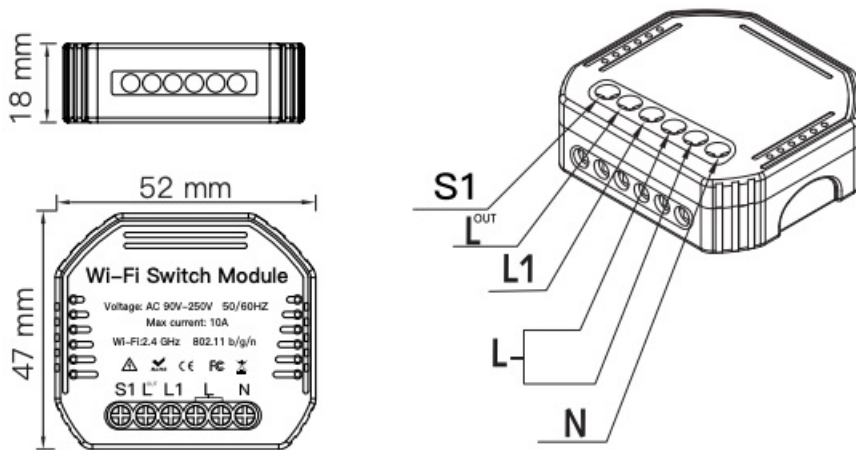

TECHNICAL SPECIFICATIONS

Product type	WiFi Switch Module
Voltage	90–250V AC
Current	10A
WiFi frequency	2.4GHz – 2.4835GHz WIFI
Operation temp.	–10°C – +40°C
Case temp.	Tc: +80°C (Max.)
Operation range	≤ 200 m
Dims (WxDxH)	52x47x18 mm
IP rating	IP20
Warranty	1 years

WIRING DIAGRAM

1. With one switch

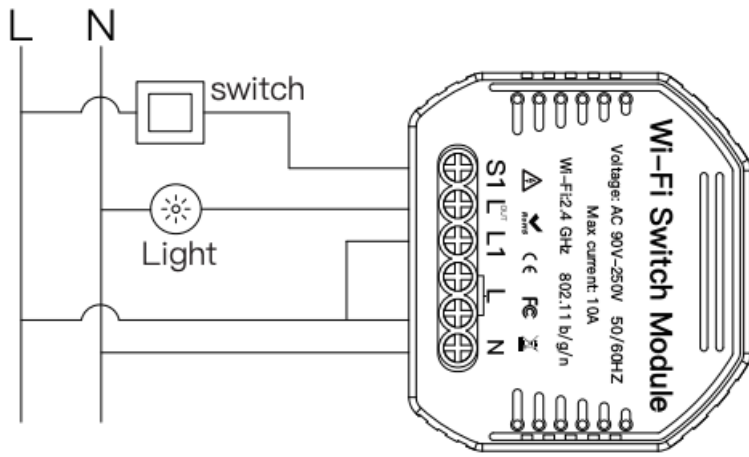

2. Without switch

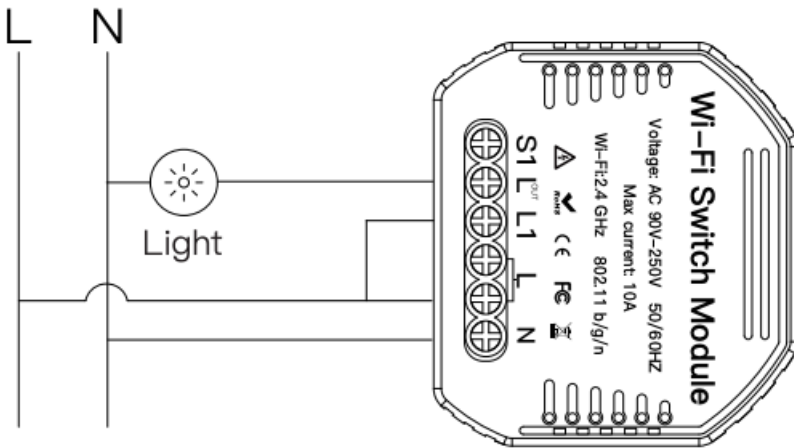

3. With 2 Way switches

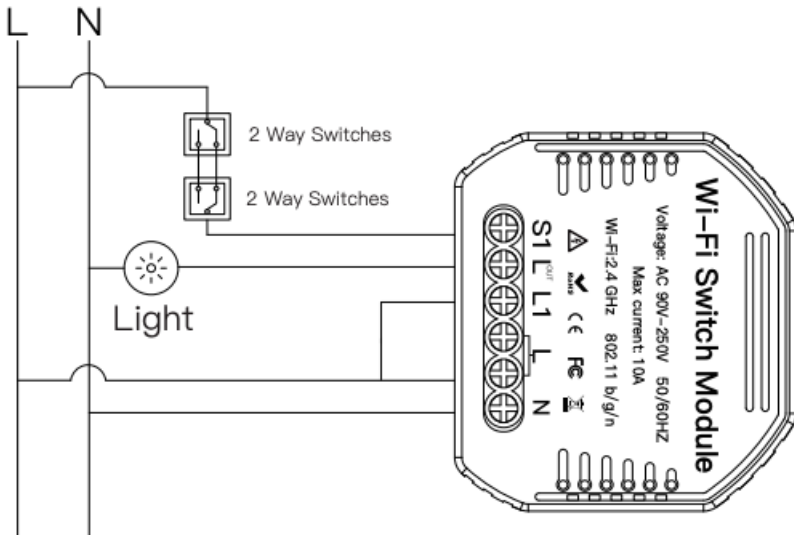

4. With Wall Socket

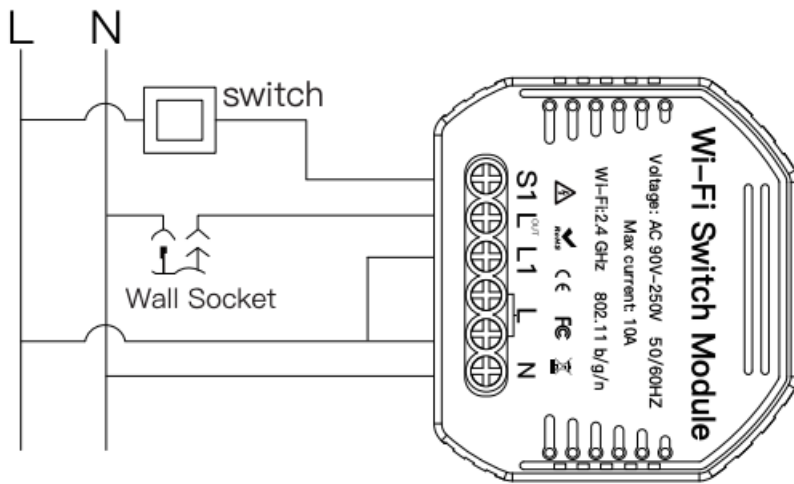

Wiring Instructions and Diagrams

1. Turn off the power supply before carrying out any electrical installation work.
2. Connect wires according to the wiring diagram.
3. Insert the module into the junction box.
4. Connect the power supply and follow switch module configuration instructions.

Notes: Take your smartphone close to the switch module when you're configuring, and make sure you have min. 50% Wi-Fi signal.

FAQ

Q1: What should I do if I can't configure the switch module?

- a. Please check whether device is powered on.
- b. Make sure your mobile and switch module are under the same 2.4 Ghz WIFI network.
- c. Whether it's in good internet conditions.
- d. Make sure the password entered in App is correct.
- e. Make sure the wiring is correct.

Q2: What device can be connected to this Wi-Fi switch module?

Most of your household electrical appliances can be, such as lamps, laundry machine, coffe maker, etc.

Q3: What happens if the WIFI goes off?

You can still control the device connected the switch module with your traditional switch and once WIFI is active again the device connected to module will connect automatically to your WIFI network.

Q4: What should I do if I change the WIFI network or change the password?

You have to re-connect our Wi-Fi switch module to the new Wi-Fi network accordingly as per the App User Manual.

Q5: How do I reset the device?

Power on/off device 5 times until the beeper on the module sound continuously.

MANUAL OVERRIDE

The switch module terminal reserves the access of manual override function for the end-user to switch on/off.

- Switch on/off for permanent on/off function.

Notes:

1. Both the adjustment on App and switch can over write each other, the last adjustment remains in memory.
2. The App control is synchronized with the manual switch.

APP USER MANUAL

1. IOS APP / Android APP



Scan the QR code to download Smart Life App, or you can also search keyword “Smart Life” at App Store or Googleplay to download App.

2. Log in or register your account with your mobile number or e-mail address. Type in the verification code sent to your mobile or mail box, then set your login password. Click “Create Family” to enter into the APP.



3. After the wiring of switch module is done, press the traditional switch to turn ON/OFF cycle for 5 times (keep time interval not too short) until the beep sound continuously for pairing mode.

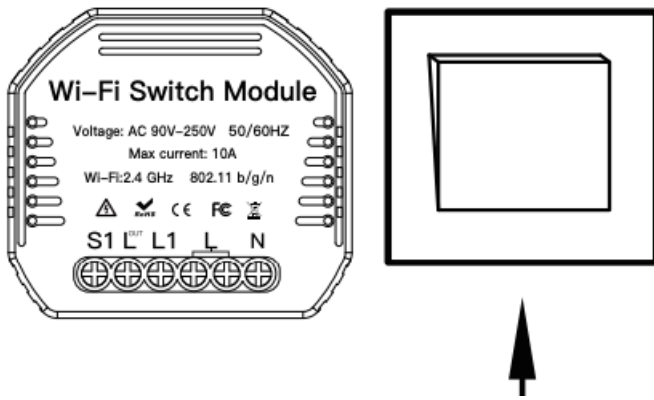

4. Open the APP, selecting “+” on top right to add device. Choose the type of device, for example “Smart Lighting”.

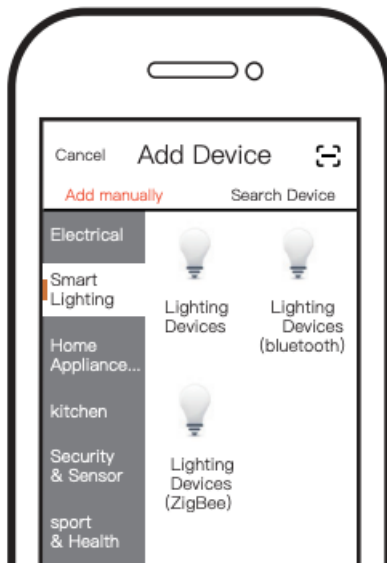

5. Make sure your smart phone and Wi-Fi switch module are under the same Wi-Fi network at 2.4Ghz connection. Confirm when the light blinks rapidly (twice a second).



6. The connecting will take about 10-120 seconds to complete depending on your network condition.

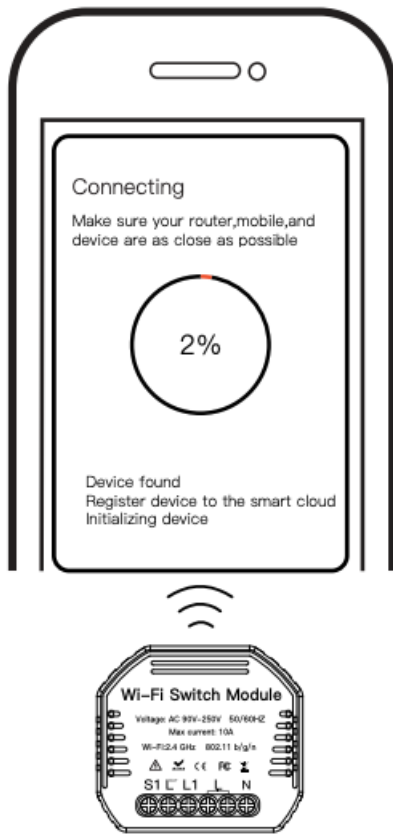

7. When pairing is done, the Wi-Fi switch will be shown on the App.

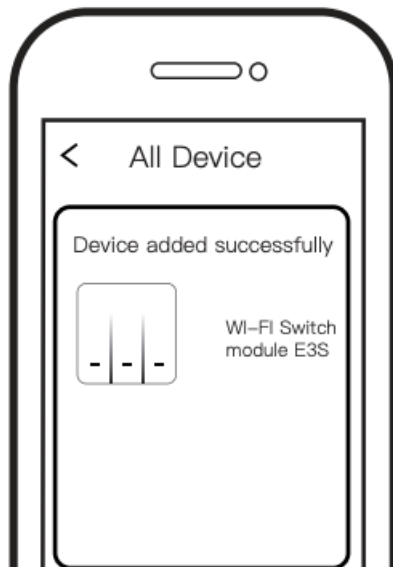

8. Connect to amazon alexa or Google Assistant for voice control, or share the devices with your families or friends.

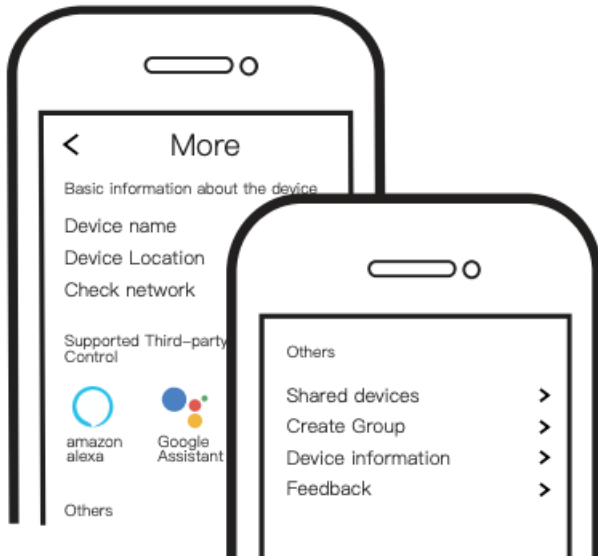

9. Enjoy your smart life of home automation for lighting control by using our All-in-one mobile app wherever you are in the world or simply by voice control when you are sitting at home comfortably.

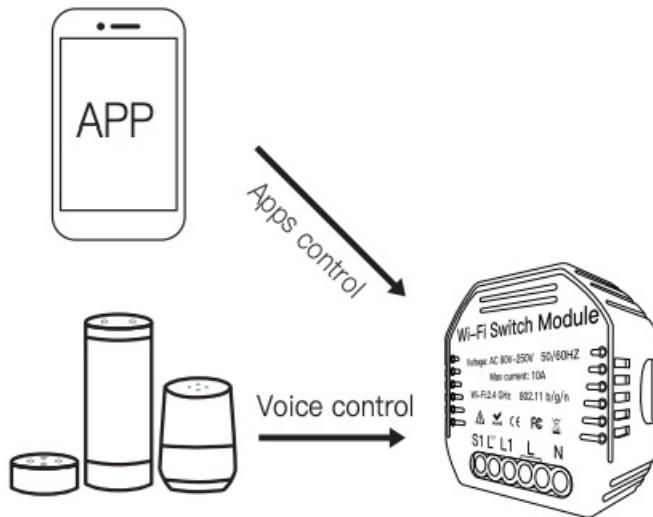

Documents / Resources

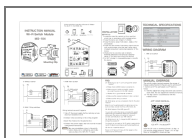

[MoseHouse WiFi Switch Module MS-104](#) [pdf] Instruction Manual
WiFi Switch Module MS-104