



Milesight UC300 IoT Controller User Guide

[Home](#) » [Milesight](#) » Milesight UC300 IoT Controller User Guide 

Contents

- [1 Milesight UC300 IoT Controller](#)
- [2 Safety Precautions](#)
- [3 FCC Statement](#)
- [4 Product Introduction](#)
- [5 Hardware Introduction](#)
- [6 Hardware Installation](#)
 - [6.1 Antenna Installation](#)
- [7 Operation Guide](#)
 - [7.1 Data Interface Settings](#)
- [8 Maintenance](#)
 - [8.1 Reset to Factory Default](#)
- [9 Device Payload](#)
- [10 For assistance, please contact](#)
- [11 Documents / Resources](#)
- [12 Related Posts](#)



Milesight UC300 IoT Controller



Safety Precautions

Misesight will not shoulder responsibility for any loss or damage resulting from not following the instructions of this operating guide.

- The device must not be remodeled in any way.
- Do not place the device close to objects with naked flames.
- Do not place the device where the temperature is below/above the operating range.
- Power off the device when installing or wirings.
- Make sure electronic components do not drop out of the enclosure while opening.
- The device must never be subjected to shocks or impacts.

Declaration of Conformity

UC300 is in conformity with the essential requirements and other relevant provisions of the CE, FCC, and RoHS.

FCC Statement

Any Changes or modifications not expressly approved by the party responsible for compliance could void the user's authority to operate the equipment. This device complies with part 15 of the FCC Rules. Operation is subject to the following two conditions:

1. This device may not cause harmful interference.

2. This device must accept any interference received, including interference that may cause undesired operation.

Note: This equipment has been tested and found to comply with the limits for a Class B digital device, pursuant to part 15 of the FCC Rules. These limits are designed to provide reasonable protection against harmful interference in a residential installation. This equipment generates, uses and can radiate radio frequency energy and, if not installed and used in accordance with the instructions, may cause harmful interference to radio communications. However, there is no guarantee that interference will not occur in a particular installation. If this equipment does cause harmful interference to radio or television reception, which can be determined by turning the equipment off and on, the user is encouraged to try to correct the interference by one or more of the following measures:

- Reorient or relocate the receiving antenna.
- Increase the separation between the equipment and receiver.
- Connect the equipment into an outlet on a circuit different from that to which the receiver is connected.
- Consult the dealer or an experienced radio/TV technician for help.

FCC Radiation Exposure Statement: This equipment complies with FCC radiation exposure limits set forth for an uncontrolled environment. This equipment should be installed and operated with minimum distance 20cm between the radiator& your body. This transmitter must not be co-located or operating in conjunction with any other antenna or transmitter.

Copyright © 2011-2022 Milesight. All rights reserved.

All information in this guide is protected by copyright law. Whereby, no organization or individual shall copy or reproduce the whole or part of this user guide by any means without written authorization from Xiamen Milesight IoT Co., Ltd.

Product Introduction

Overview

UC300 is an IoT controller used for remote control and data acquisition from multiple sensors. It contains different I/O interfaces such as analog inputs, digital inputs, relay outputs, serial ports and so on, which support remote device data transmission and control via LoRaWAN®. Besides, UC300 supports multiple trigger conditions and actions which works autonomously even when the network drops.

Features

- Easy to connect with diverse wired sensors through DI/DO/AI/PT100/RS232/RS485 interfaces
- Support LoRaWAN® wireless communication
- Multiple triggering conditions and actions
- Embedded watchdog for work stability
- Industrial metal case design with wide operating temperature range
- Compliant with standard LoRaWAN® gateways and network servers
- Quick and easy management with Milesight IoT Cloud solution

Hardware Introduction

Packing List

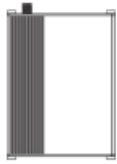

1 × UC300 Device



1 × LoRaWAN® Antenna

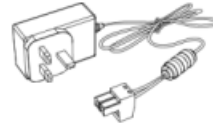

1 × Power Adapter



5 × Terminal Blocks



1 × DIN Rail Mounting Clip



4 × Wall Mounting Kits



4 × Fixing Screws



1 × Quick Start Guide



1 × Warranty Card

- If any of the above items is missing or damaged, please contact your sales representative.

Hardware Overview

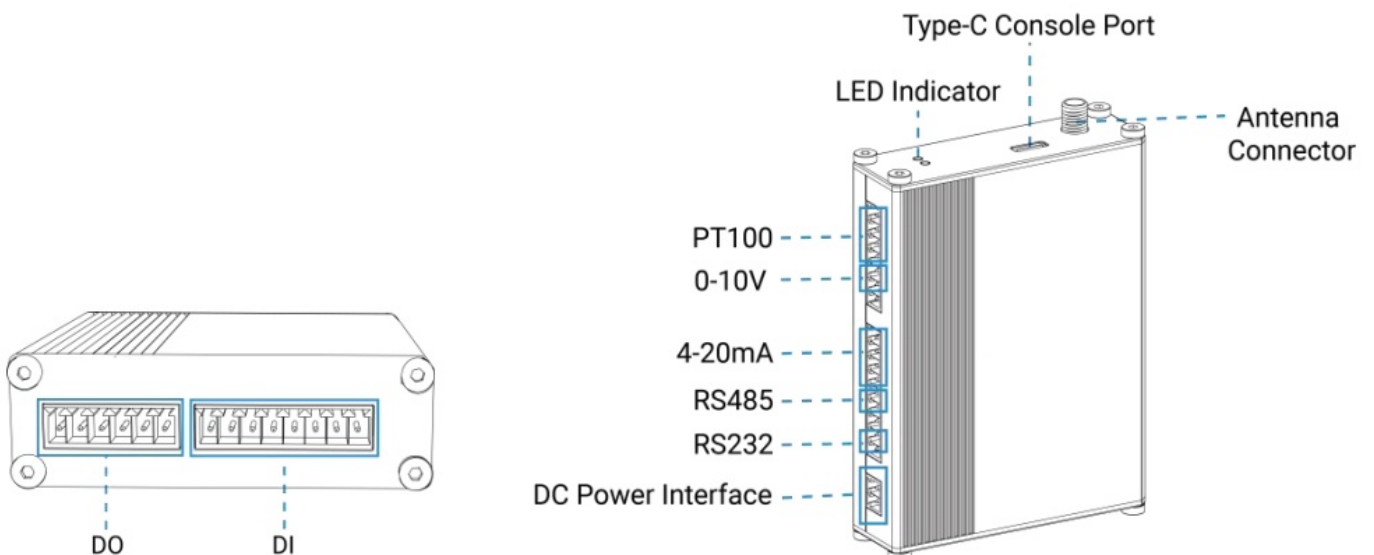

Application Wiring

- **V+**: positive of external power source/UC DC 5- 24V
- **V-** : negative of external power source/UC DC 5- 24V

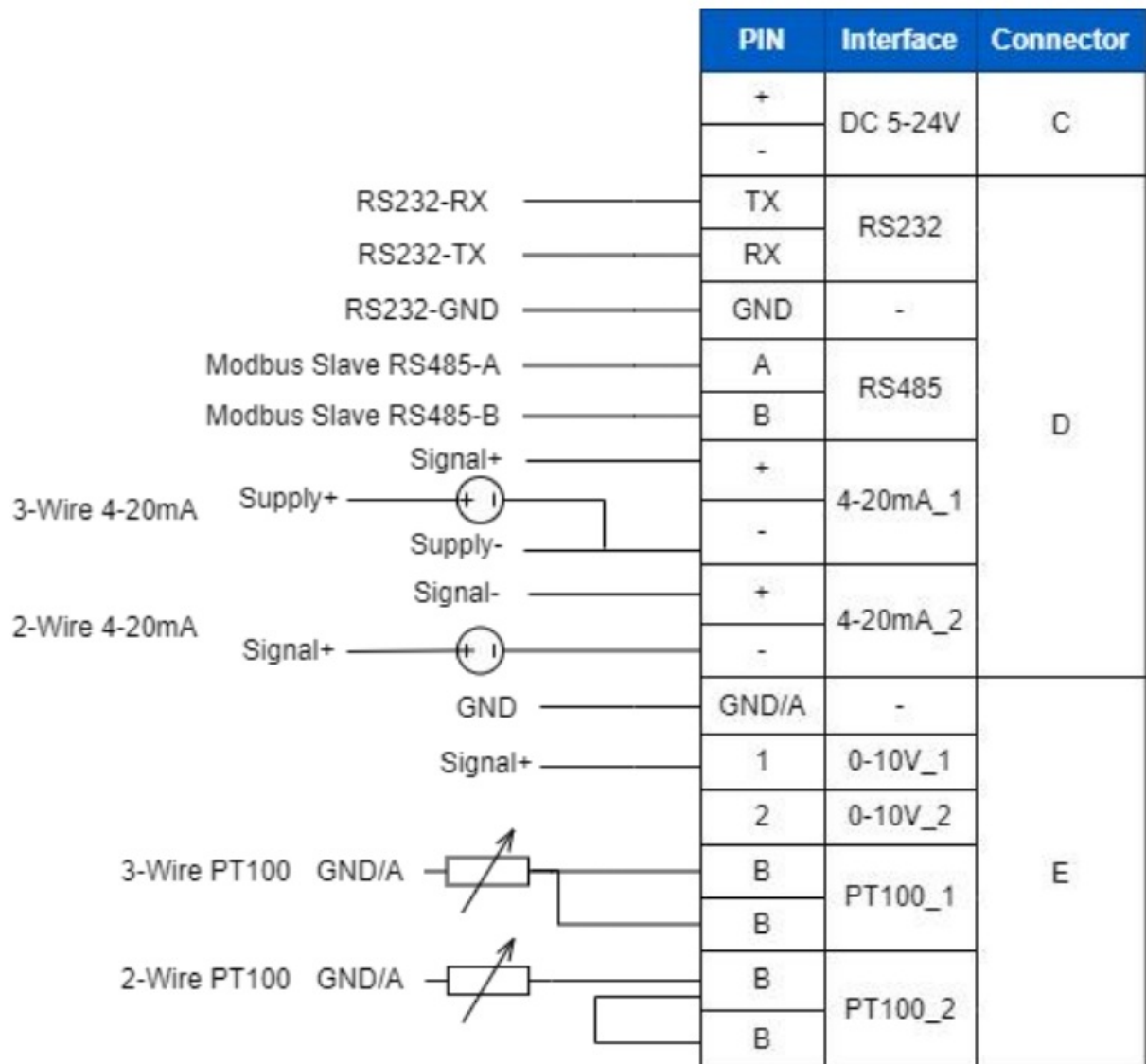
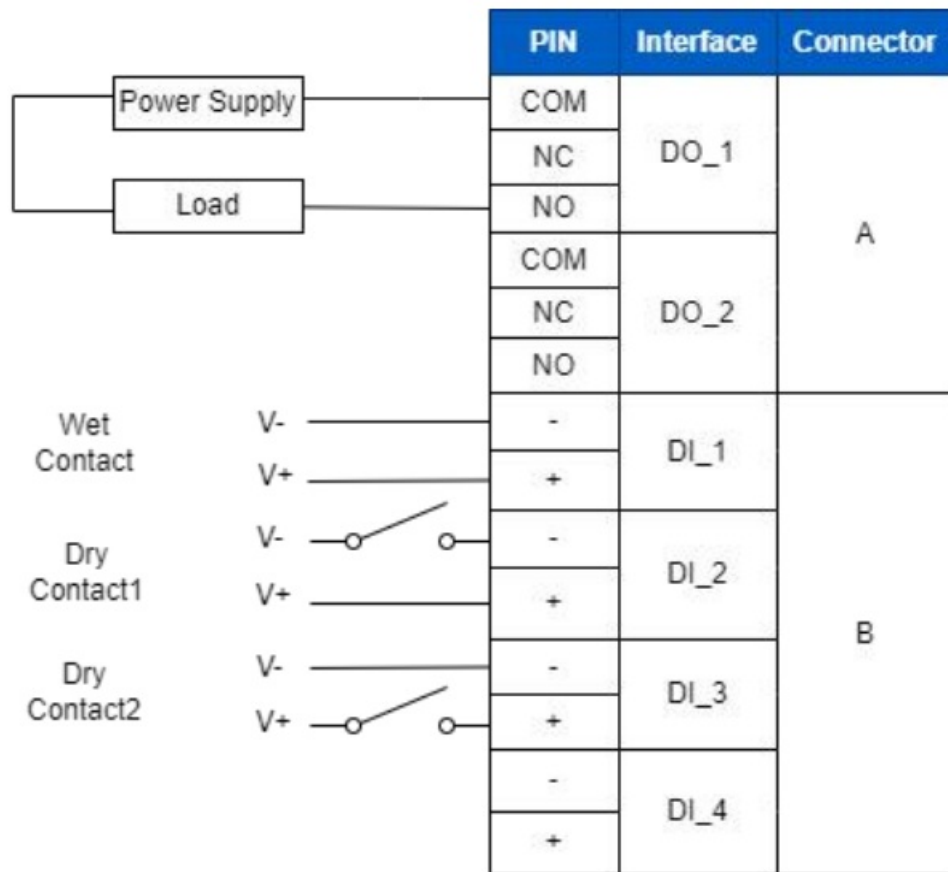

RS485 Terminal Resistor

DIP Switch	Description
1 on 2 off 3 off	Add 120 Ω resistor between A and B
1 off 2 on 3 off	Add pull-down resistor on B
1 off 2 off 3 on	Add pull-up resistor on A

LED Indicators

LED	Indication	Status	Description
SYS	System Status	Static On	System works
		Slowly Blinks	Fail to acquire data from data interfaces
		Static On	System error
ACT	Network Status	Off	Not join/register to the network
		Blinks as Requests	Send join network requests
		Blinks Twice \rightarrow Static On	Succeed to join to network
		Blinks Once	Succeed to send uplinks
		Blinks Twice	Fail to send uplinks
		Blinks Twice	Receive downlinks

Reset Button

- There is reset button inside the device

Function	Description	
	SYS LED	Action
Reset	Static Green	Press and hold the reset button for more than 10 seconds.
	Static Green \rightarrow Rapidly Blinking	Release the button and wait.
	Off \rightarrow Static Green	The device resets to factory default.

Dimensions (mm)

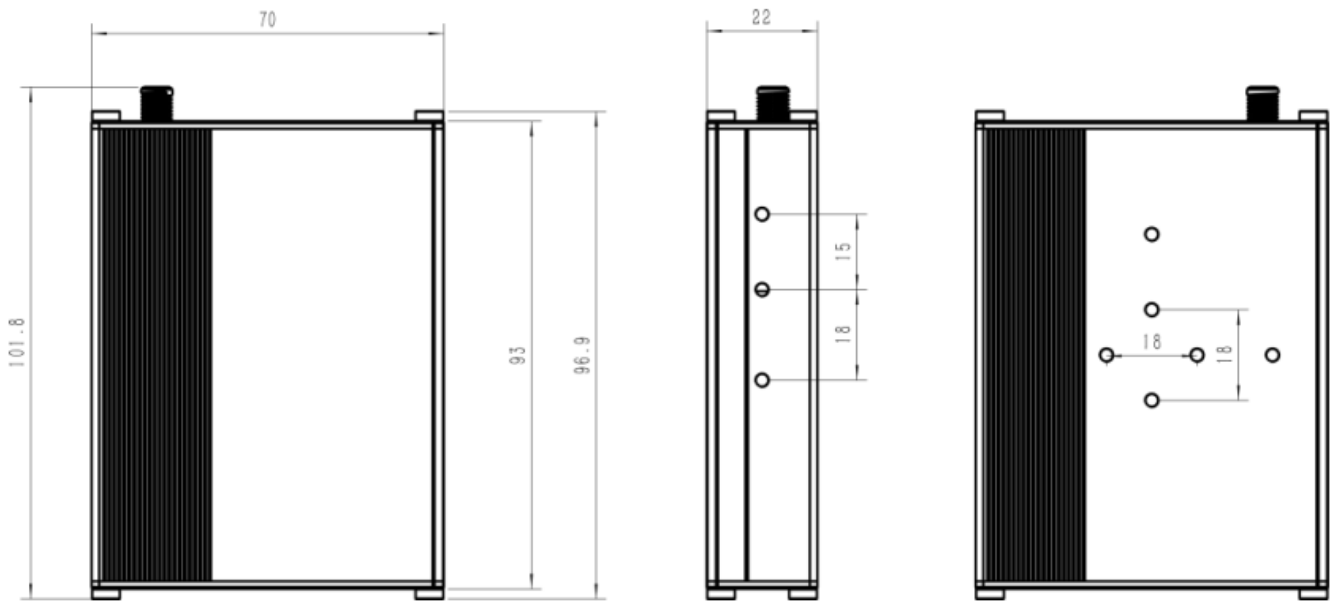

Hardware Installation

Antenna Installation

Installation Instructions

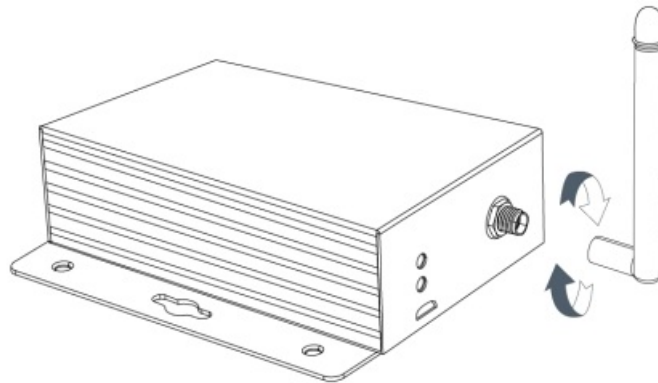

- Rotate the antenna into the antenna connector accordingly.
- The external antenna should be installed vertically always on a site with a good signal.

Note

1. The external antenna should be installed vertically always on a site with a good signal.
2. Keep away from metal objects and power lines which may affect the signal.

Antenna Specifications

Milesight provides a 108 mm LoRaWAN antenna for UC300 and here is the specification:

Electrical Properties

Frequency Range	902~928 MHz
Impedance	50Ω Nominal
VSWR	2.2:1 Max.
Return Loss	8.5 dB Min.
Radiation	Omni-directional
Gain(Peak)	1dBi
Polarization	Linear
Admitted Power	1W
Connector	SMA Plug Standard

Physical Characteristics

Operating Temperature	-10°C ~ 60°C
Storage Temperature	-10°C ~ 70°C

Device Installation

- UC300 device can be placed on a desktop or mounted to a wall or a DIN rail.

Wall Mounting

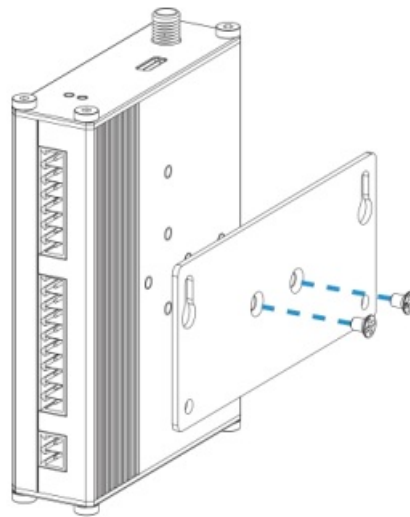

1. Fix the wall mounting bracket to the device with 2 screws.
2. Drill 4 holes on the wall according to the bracket, then fix the wall plugs into the wall.

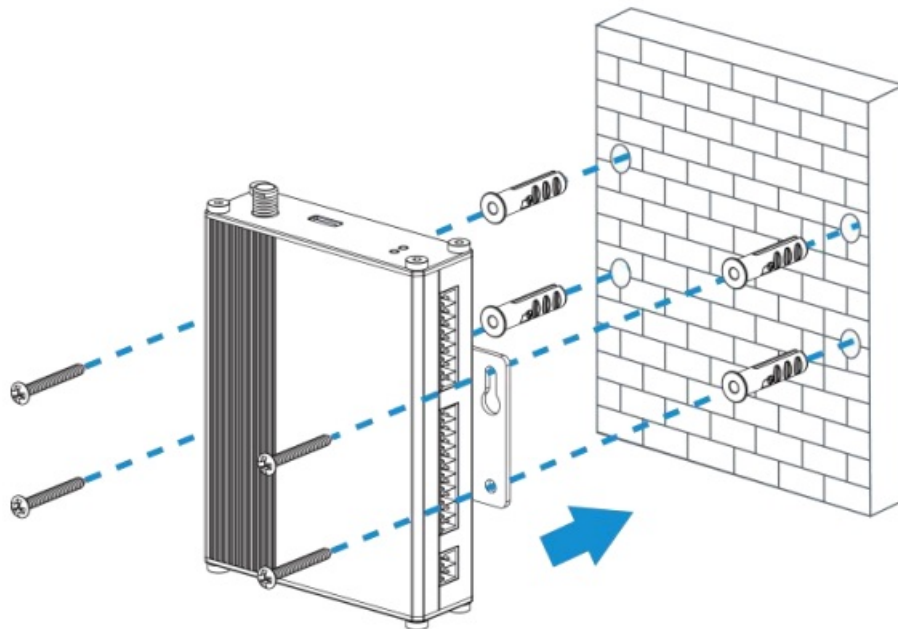

3. Fix the device to the wall plugs with screws. When installation, it's suggested to fix the two screws on the top at first.

DIN Rail Mounting

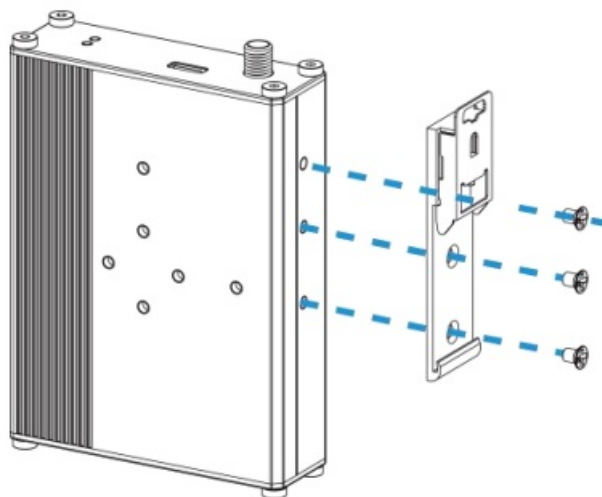

1. Fix the mounting clip to the device with 3 screws.
 - You can also try below installation methods:

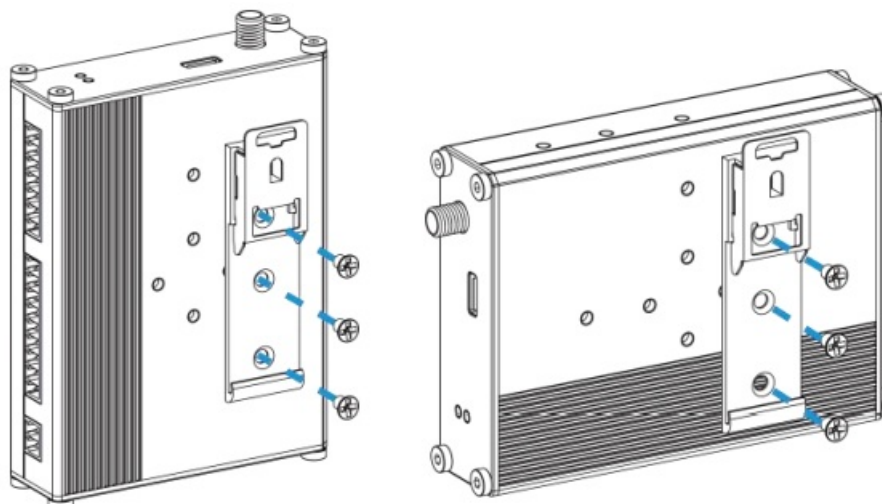

2. Hang the device to the DIN rail. The width of DIN rail is 3.5cm.

Operation Guide

Log in the ToolBox

1. Download ToolBox software from Milesight IoT website.

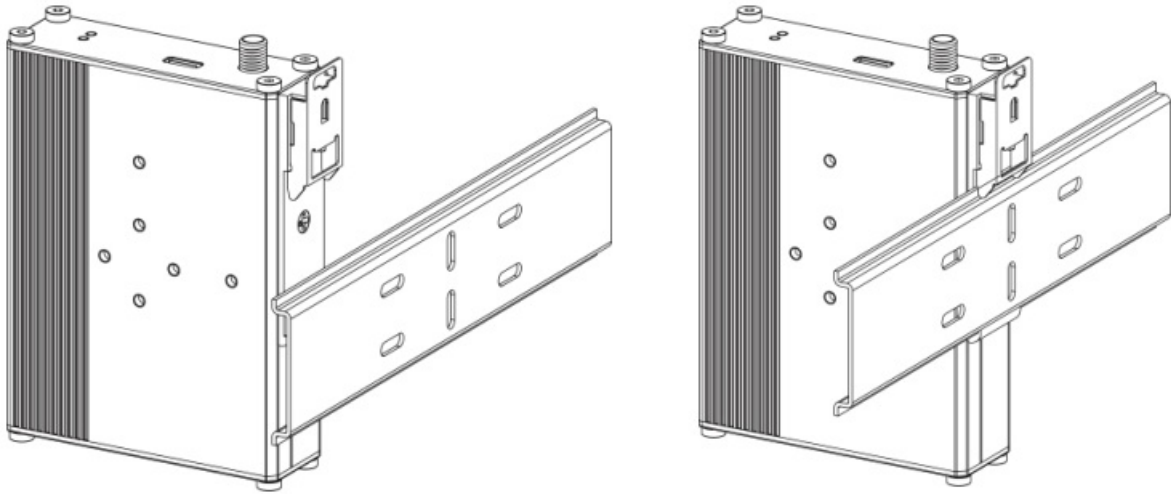

2. Power on the UC300 device, then connect it to computer via type-C port.



3. Open the ToolBox and select type as "General", then click password to log in ToolBox. (Default password: 123456)

ToolBox Settings

Type	General
Serial port	COM4
Login password	
Baud rate	115200
Data bits	8
Parity bits	None
Stop bits	1

Save Cancel

4. After logging in the ToolBox, you can change device settings.

Status >	
Model:	UC300-470M
Serial Number:	6445B43411300001
Device EUI:	24e124445b434113
Firmware Version:	01.01-a8
Hardware Version:	1.0
Join Status:	Activate
RSSI/SNR:	-116/-22
Channel Mask:	00000000000000000000#00
Uplink Frame-counter:	7
Downlink Frame-counter:	0
Device Time:	2022-03-17 09:47:19 Sync

LoRaWAN Settings

LoRaWAN settings is used for configuring the transmission parameters in LoRaWAN® network and is only applied to UC300 LoRaWAN® version.

Basic LoRaWAN Settings

Device EUI	<input type="text" value="24E124445B434113"/>
App EUI	<input type="text" value="24E124C0002A0001"/>
Application Port	<input type="text" value="85"/>
Join Type	<input type="text" value="OTAA"/>
Class Type	? <input type="text" value="Class C"/>
Application Key	<input type="text" value="*****"/>
RX2 Date Rate	<input type="text" value="DR0 (SF12, 125 kHz)"/>
RX2 Frequency	<input type="text" value="505300000"/>
Spread Factor	? <input type="text" value="SF10-DR2"/>
Confirmed Mode	? <input type="checkbox"/>
Rejoin Mode	? <input checked="" type="checkbox"/>
Set the number of packets sent	<input type="text" value="32"/> packets
ADR Mode	? <input checked="" type="checkbox"/>

- Go to “LoRaWAN Settings -> Basic” to configure join type, App EUI, App Key and other information. You can also keep all settings by default.

Parameters	Description
Device EUI	Unique ID of the device on the label.
App EUI	Default App EUI is 24E124C0002A0001.
Application Port	The port used for sending and receiving data (RS232 data excluded), default port is 85.
Working Mode	Fixed as Class C.
Join Type	OTAA and ABP modes are available.
Application Key	Appkey for OTAA mode, default is 5572404C696E6B4C6F52613230313823.
Device Address	DevAddr for ABP mode, default is the 5th to 12th digits of SN.
Network Session Key	Nwkskey for ABP mode, default is 5572404C696E6B4C6F52613230313823.
Application Session Key	Appskey for ABP mode, default is 5572404C696E6B4C6F52613230313823.
RX2 Data Rate	RX2 data rate to receive downlinks.
RX2 Frequency	RX2 frequency to receive downlinks. Unit: Hz

Spread Factor	If ADR is disabled, the device will send data via this spread factor.
Confirmed Mode	If the device does not receive ACK packet from network server, it will resend
	data 3 times at most.
Rejoin Mode	<p>Reporting interval \leq 30 mins: device will send specific mounts of LoRaMAC packets to check connection status every 30 mins; If not receiving response after specific packets, the device will re-join.</p> <p>Reporting interval $>$ 30 mins: device will send specific mounts of LoRaMAC packets every reporting interval; If not receiving response after specific packets, the device will re-join.</p>
ADR Mode	Allow network server to adjust datarate of the device.

Note

1. Please contact sales for device EUI list if there are many units.
2. Please contact sales if you need random App keys before purchasing.
3. Select OTAA mode if you use Milesight IoT Cloud to manage devices.
4. Only OTAA mode supports rejoin mode.

Data Interface Settings

Basic Settings

Device ID	<input type="text" value="6445C06166800001"/>
Reporting Interval(min)	<input type="text" value="20"/>
LoRa D2D	<input type="checkbox"/>
D2D Key	<input type="text" value="*****"/>
Change Password	<input type="checkbox"/>

Parameters	Description
Device ID	Show the SN of the device.
Reporting Interval	Reporting interval of transmitting data to network server.Default: 20mins Note: RS232 transmission will not follow the reporting interval.
LoRa D2D	See details on chapter 4.5 .
Change Password	Change the password to login ToolBox.

Digital Input/Pulse Settings

Interface Name DI_1

Enable

Interface Type Digital Input ▾

Status ✔ Fetch

Interface Name DI_2

Enable

Interface Type Counter ▾

Digital Filter ?

Counter Values ✔ Refresh Start Clear

UC300 supports 4 digital inputs and every input can work as either digital input mode to detect high/low level or pulse counter to record counting values. When working as digital input, UC300 will upload the data according to reporting interval or when status changes.

Parameters	Description
Enable	Enable digital input to detect status and upload the data.
Digital Input	
Fetch	Click to get the current input status.
Counter	
Digital Filter	It's recommended to enable when pulse period is greater than 250 us.
Start/Stop	Click to start/stop counting. Note that UC300 will send non-changeable counting values if you do not click "Start".
Refresh	Refresh to get latest counter values.
Clear	Count the value from 0.

Note: the counting value will lose if UC300 loses the power.

Digital Output Settings

Interface Name	DO_1	
Enable	<input checked="" type="checkbox"/>	
When Power is Restored, DO	Return to Previous Working State	
Status	Closed <input type="checkbox"/> <input checked="" type="checkbox"/> Fetch Switch	
Interface Name	DO_2	
Enable	<input checked="" type="checkbox"/>	
When Power is Restored, DO	Turn to Normally Closed	
Status	Open <input type="checkbox"/> <input checked="" type="checkbox"/> Fetch Switch	

- UC300 supports 2 digital outputs to control the devices.

Parameters	Description
Enable	Enable the digital output to control the device and upload changed status.
When Power is Restored, DO	After the device power is restored, the DO status will return to normally closed or normally open according to this parameter.
Fetch	Click to get the current output status.
Switch	Click to change the DO status.

RS485 Settings

UC300 has one RS485 port for Modbus RTU device connection.

Enable	<input checked="" type="checkbox"/>
Stop Bit	<input type="text" value="1 bits"/>
Data Bit	<input type="text" value="8 bits"/>
Parity	<input type="text" value="None"/>
Baud Rate	<input type="text" value="9600"/>
Execution Interval (ms)	<input type="text" value="50"/>
Max Resp Time (ms)	<input type="text" value="500"/>
Max Retry Times	<input type="text" value="3"/>
Modbus RS485 bridge LoRaWAN ?	<input checked="" type="checkbox"/>
Port ?	<input type="text" value="0"/>

1. Connect RS485 device to RS485 port.
2. Go to "General -> RS485" to enable RS485 and configure serial port settings. Serial port settings should be the same as the RS485 terminal devices.

Parameters	Description
Enable	Allow the device to collect RS485 data and upload the data.
Stop Bit	1 bit/2 bit are available.
Data Bit	8 bit is available.
Parity	None, Odd and Even are available.
Baud Rate	1200/2400/4800/9600/19200/38400/57600/115200 are available.
Execution Interval (ms)	The execution interval between each Modbus channel command.
Max Resp Time (ms)	The maximum response time that the UC300 waits for the reply to the command. If it does not get a response after the max response time, it is determined that the command has timed out.
Max Retry Time (ms)	Set the maximum retry times after device fails to read data from RS485 terminal devices.
Modbus RS485 bridge LoRaWAN	<p>If this mode is enabled, the device will transmit Modbus RTU commands from network server to RS485 terminal devices transparently and send Modbus reply originally back to the network server.</p> <p>Port: Select from 2-84, 86-223.</p>

1. Click + to add Modbus channels, then save configurations.

Channel Settings Fetch All

Channel ID	Name	Slave ID	Address	Quantity	Type	Byte Order	Sign	Value
1	1	1	0	1	Input Register(INT16)	AB	<input type="checkbox"/>	<input type="text"/> Fetch
2	test	255	535	2	Coil		<input checked="" type="checkbox"/>	<input type="text"/> Fetch

Save Up to 16 channels

Parameters	Description
Channel ID	Select the channel ID you want to configure from 16 channels.
Name	Customize the name to identify every Modbus channel.
Slave ID	Set Modbus slave ID of terminal device.
Address	The starting address for reading.
Quantity	Set read how many digits from starting address. It fixes to 1.
Type	Select data type of Modbus channels.
Byte Order	Set the Modbus data reading order if you configure the type as Input register or holding register. INT32/Float: ABCD, CDBA, BADC, DCBA INT16: AB, BA
Sign	The tick indicates that the value has a plus or minus sign.

Fetch

After click, UC300 will send Modbus read command to test if it can read correct values.

Example: as this setting, the device will send command: 01 03 00 00 00 01 84 0A

Channel ID	Name	Slave ID	Address	Quantity	Type	Byte Order	Sign	Value	
1	temperature	1	0	1	Holding Register(INT16)	AB	<input type="checkbox"/>		<input checked="" type="checkbox"/> Fetch

1. Click "Fetch" to check if UC300 can read correct data from terminal devices.

Channel ID	Name	Slave ID	Address	Quantity	Type	Byte Order	Sign	Value	
4	C	1	0	1	Input Register(INT16)	AB	<input type="checkbox"/>	21	<input checked="" type="checkbox"/> Fetch

Note: Do not click "Fetch" frequently since response time to reply is differ for every terminal device.

RS232 Settings

Enable	<input checked="" type="checkbox"/>
Baud Rate	9600
Stop Bit	1 bits
Data Bit	8 bits
Parity	None
Packet Length (byte)	256
Serial Frame Interval (ms)	100
Port	86

- UC300 has one RS232 interface for transparent communication. Usually, it will use different tunnels from other data interfaces to communicate with server.

Parameters	Description
Baud Rate	1200/2400/4800/9600/19200/38400/57600/115200 are available.
Data Bit	8 bit is available.
Stop Bit	1 bit/2 bit are available.
Parity	None, Odd and Even are available.
Packet Length (byte)	When the device receives RS232 data up to this length, it will fragment it as a single packet and send to network server.
Serial Frame Interval (ms)	The interval that the device sends out real serial data stored in the buffer area to public network. The range is 10-65535 milliseconds. Note: data will be sent out when real serial data size reaches the preset packet size, even though it's within the serial frame interval.
Port	Send or receive RS232 data from this port, this port should be different from the Application port. Range: 2-84, 86-223.

Analog/PT100 Settings

UC300 has two 4-20mA analog inputs, two 0-10V analog inputs and two PT100 inputs for analog device connection. After wirings, you can click "Fetch" to check if the value is correct.

PT100 Note

Interface Name	? 4-20mA_1
Enable	<input checked="" type="checkbox"/>
Osh	<input type="text" value="20.00"/>
Osl	<input type="text" value="4.00"/>
Unit	<input type="text" value="mA"/>
Status	<input type="text"/> ✓ Fetch

Interface Name	? 0-10V_1
Enable	<input checked="" type="checkbox"/>
Osh	<input type="text" value="10.00"/>
Osl	<input type="text" value="0.00"/>
Unit	<input type="text" value="V"/>
Status	<input type="text" value="0.00V"/> ✓ Fetch

Interface Name	PT100_1
Enable	<input checked="" type="checkbox"/>
Unit	<input type="text" value="°C"/>
Status	<input type="text"/> ✓ Fetch

1. The temperature unit in the reporting package is fixed as °C.
2. Please modify the command IF condition threshold settings if you change the temperature unit.

IF-THEN Command

UC300 supports configuring locally IF-THEN commands to do some actions automatically even without network connection. One device can be added 16 commands at most.

1. Go to "Command" page, click "Edit" to add commands.

Settings >

Save

ID	Configuration	Edit	Delete
1	If pt100(pt100_2) is above 35.00 continued for 0s. then do_1 will be normally open in 0s and it will last for 0s .		
2			
3			
4			
5			

Configuration for command NO.2

If

Is continued for

Set lockout time

2. Set a IF condition based on the terminal device data or UC300 device status.

Condition	Description
Time	Set the time condition. The device time will be synced once after joining/registering to network, you can also sync the time manually on "Status" page.
Digital Input	When UC300 device detects the DI as a specific status. Is continued for: the DI changed status should last for some time. Set lockout time: after the lockout time, UC300 will detect if DI status matches the condition. 0 means this IF condition will only be detected once.

Counter	When pulse counter reaches a specific value. This only works when DI works as counter mode.
Channel/4-20mA/0-10V/PT100	<p>When the value reaches any threshold.</p> <p>Is continued for: the analog value should last for some time.</p> <p>Set lockout time: after the lockout time, UC300 device will detect if analog value matches the condition. 0 means this IF condition will only be detected once.</p>
Received a message	When UC300 device receive a specific message from server.
The Device Restarts	Reboot the device.
Received a D2D control command	This only works with UC300 LoRaWAN® version and the LoRa D2D feature is enabled. See details on chapter 4.5.

1. Set THEN action according to your request. You can add at most 3 actions in one command.

Action	Description
Send a custom message	Send a custom message to the server.
Output Trigger	DO can be set to normally open/normally closed/change status. Delay Time: this action will trigger after a specific time; Duration: the output status will last for a specific time, 0 means permanent.
Restart the Device	Reboot the device.
Send a D2D control command	This only works when Milesight D2D feature is enabled. See details on chapter 4.5.
Send a Modbus command via RS485 interface	This only works when Milesight D2D feature is enabled. See details on chapter 4.5.

Milesight D2D Settings

Milesight D2D protocol is developed by Milesight and used for setting up transmission among Milesight devices without gateway. When the Milesight D2D setting is enabled, UC300 can work as a Milesight D2D controller to send control commands to other devices or work as a Milesight D2D agent to receive commands to trigger the DO or RS485 devices.

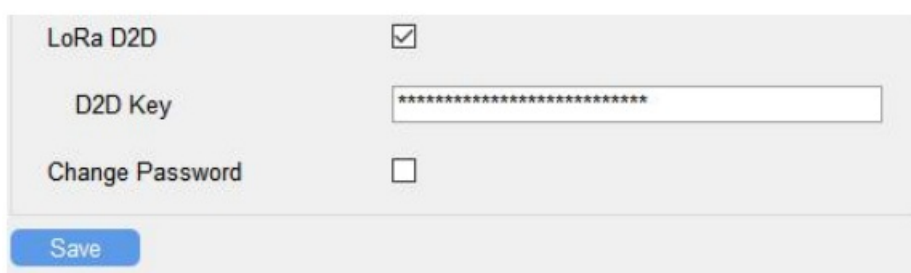

The screenshot shows a configuration form for Milesight D2D settings. It includes three main options: 'LoRa D2D' which is checked, 'D2D Key' which has a text input field containing a series of asterisks, and 'Change Password' which is unchecked. A blue 'Save' button is located at the bottom left of the form area.

1. Go to "General -> Basic" page, enable Milesight D2D feature, define a unique D2D key which is the same as

D2D controller or agent devices. (Default D2D Key: 5572404C696 E6B4C6F52613230313823)

The screenshot shows the 'LoRaWAN >' configuration page with the 'Channel' tab selected. The configuration includes the following fields:

- App EUI: 24E124C0002A0001
- Application Port: 85
- Join Type: OTAA
- Class Type: Class C
- Application Key: [Redacted]
- RX2 Date Rate: DR0 (SF12, 125 kHz)**
- RX2 Frequency: 505300000**
- Spread Factor: SF10-DR2
- Confirmed Mode: [Unchecked]

2. Go to “LoRaWAN Settings -> Basic” to configure the RX2 datarate and RX2 frequency. When UC300 works as D2D controller, it will send commands as RX2 settings.

The screenshot shows the 'Configuration for command NO.1' interface with the following configuration:

- If:** Digital Input
- DI 1
- goes active (rising edge-triggered)
- Is continued for: 0 s
- Set lockout time
- Then:** Send a D2D control command
- Content is:** 0001

3. Go to “Command” page to set corresponding operations. When DI triggers, UC300 can work as D2D controller to send control command to control the D2D agent device. The command should be a 2-byte hexadecimal number.

Configuration for command NO.1

If

Containing

Then (+)

Delay Time s

Duration s

When UC300 receives a D2D command, it can work as a D2D agent to trigger the DO or send Modbus command to RS485 terminal devices.

Configuration for command NO.1

If

Containing

Then (+)

Content is

Note: When this feature is enabled and the command is triggered, the device will not send data to LoRaWAN® network server.

Maintenance

Upgrade

UC300 supports upgrade locally via ToolBox software.

The screenshot shows a web interface with two tabs: 'Upgrade' and 'Backup and Reset'. The 'Upgrade' tab is selected. Below the tabs, the following information is displayed:

- Model: UC300-470M
- Firmware Version: 01.01
- Hardware Version: 1.0
- Domain: Beijing Server (dropdown menu)
- FOTA: Up to date (button)
- Local Upgrade: [input field] [Browse] [Upgrade]

1. Download firmware from www.milesight-iot.com to your PC.
2. Go to "Maintenance -> Upgrade", click "Browse" to import firmware and upgrade the device. You can also click "Up to Date" to search for the latest firmware of the device and upgrade.

Note: Any operation on ToolBox is not allowed during upgrading, otherwise the upgrading will be interrupted, or even the device will break down.

Backup

UC300 devices support configuration backup for easy and quick device configuration in bulk. Backup is allowed only for devices with the same model and LoRa frequency band.

The screenshot shows a web interface with two tabs: 'Upgrade' and 'Backup and Reset'. The 'Backup and Reset' tab is selected. Below the tabs, the following options are available:

- Config Backup: Export (button)
- Config File: [input field] [Browse] [Import]
- Restore Factory Defaults: Reset (button)

1. Go to "Maintenance -> Backup and Reset", click "Export" to save current configuration as json format backup file.
2. Click "Browse" to select backup file, then click "Import" to import the configurations.

Reset to Factory Default

Please select one of following methods to reset device:

Config Backup	Export	
Config File		Browse Import
Restore Factory Defaults	Reset	

- **Via Hardware:** Open the case of UC300, hold on the reset button for more than 10 s until SYS LED blinks.
- **Via ToolBox Software:** Go to “Maintenance -> Backup and Reset” to click “Reset”.

Device Payload

- For UC300 LoRaWAN® version, please refer to the UC300 LoRaWAN Communication Protocol; for decoders of Milesight IoT products please click here.

For assistance, please contact

Milesight technical support

- **Email:** iot.support@milesight.com
- **Tel:** 86-592-5085280
- **Fax:** 86-592-5023065
- **Address:** Building C09, Software Park III, Xiamen 361024, China

Revision History

Date	Doc Version	Description
Mar. 17, 2022	V 1.0	Initial version

www.milesight-iot.com

Documents / Resources

	<p>Milesight UC300 IoT Controller [pdf] User Guide UC300, 2AYHY-UC300, 2AYHYUC300, UC300 IoT Controller, IoT Controller, Controller</p>
---	---

