



Mercia Garden Overlap Apex Instructions

[Home](#) » [Mercia Garden](#) » Mercia Garden Overlap Apex Instructions 

Mercia Garden Overlap Apex Instructions



Contents

- [1 General Instructions](#)
- [2 Building Content](#)
- [3 Pre Assembly](#)
- [4 Documents / Resources](#)
 - [4.1 References](#)
- [5 Related Posts](#)

General Instructions

BEFORE YOU START PLEASE READ INSTRUCTIONS CAREFULLY

- Check the pack and make sure you have all the parts listed.
- When you are ready to start, make sure you have the right tools at hand (not supplied) including a Phillips screwdriver, Stanley knife, wood saw, step ladder and drill with 2mm bit.
- Ensure there is plenty of space and a clean dry area for assembly.

TIMBER

As with all natural materials, timber can be affected during various weather conditions. For the duration of heavy or extended periods of rain, swelling of the wood panels may occur. Warping of the wood may also occur during excessive dry spells due to an interior moisture loss. Unfortunately, these processes cannot be avoided but can be helped. It is suggested that the outdoor building is sprayed with water during extended periods of warm sunshine and sheltered as much as possible during rain or snow.

Once your garden building has been installed it will need to be treated as soon as possible and annually to prevent the timber from deteriorating and to waterproof it. This is required to maintain the anti-rot guarantee. Dip Treated buildings – Require a preservative treatment to protect against rot and decay and a waterproof treatment to prevent water ingress

Pressure Treated buildings – Require a waterproof treatment to prevent water ingress

Log Cabins – Are supplied untreated and require a preservative and waterproofing treatment.

BUILDING A BASE

When thinking about where the building and base is going to be constructed: Ensure that there will be access to all sides for maintenance work and annual treatment.

Ensure the base is level and is built on firm ground, to prevent distortion. Refer to diagrams for the base dimensions, The base should be slightly smaller than the external measurement of the building, i.e. The cladding should overlap the base, creating a run off for water. It is also recommended that the floor be at least 25mm above the surrounding ground level to avoid flooding.

TYPES OF BASE

– Concrete 75mm laid on top of 75mm hard-core. – Slabs laid on 50mm of sharp sand.

Whilst all products manufactured are made to the highest standards of Safety and in the case of childrens products independently tested to EN71 level, we cannot accept responsibility for your safety whilst erecting or using this product.

Refer to the instructions pages for you specific product code

Please retain product label and instructions for future reference

All building's should be erected by two adults



Winter = High Moisture = Expansion
Summer = Low Moisture = Contraction



For ease of assembly, you **MUST** pilot drill all screw holes and ensure all screw heads are countersunk.



2mm Drill bit

CAUTION

Every effort has been made during the manufacturing process to eliminate the prospect of splinters on rough surfaces of the timber. You are strongly advised to wear gloves when working with or handling rough sawn timber.



Protim Aquatan T5 (621)

Your building has been treated with **Aquatan**.

Aquatan is a water-based concentrate which is diluted with water, the building has been treated by the correct application of Aquatan solution and then allowed to dry.

Aquatan is a decorative finish to colour the wood, which is applied industrially to timber fence panels and garden buildings.

Aquatan undiluted contains: boric acid, sodium hydroxide 32% solution, aqueous mixture of sodium dioctyl sulphosuccinat and alcohols: 2, 4, 6-trichlorophenol.

Overall Dimensions:

Length = 3028mm

Width = 2484mm

Height = 2121mm

Base Dimensions:

Length = 3000mm

Width = 1760mm

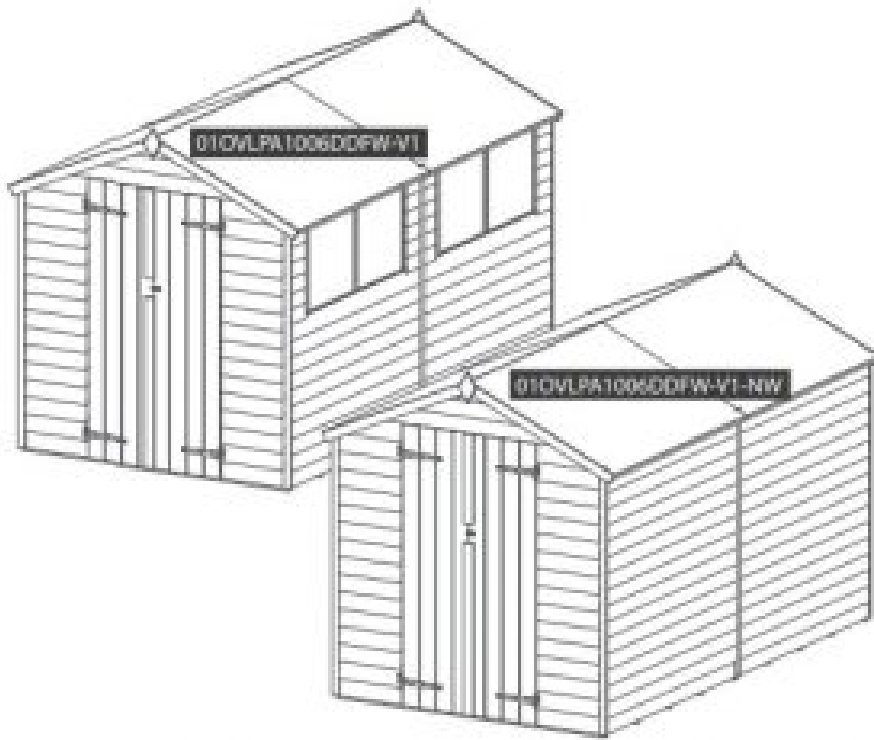

Building Content

1. Door Gable

AI-01OVLPDG1707X1960-V1

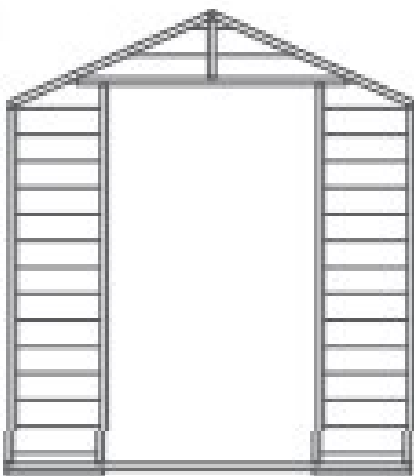

2. Back Gable

AI-01OVLPPG1707X1960-V1

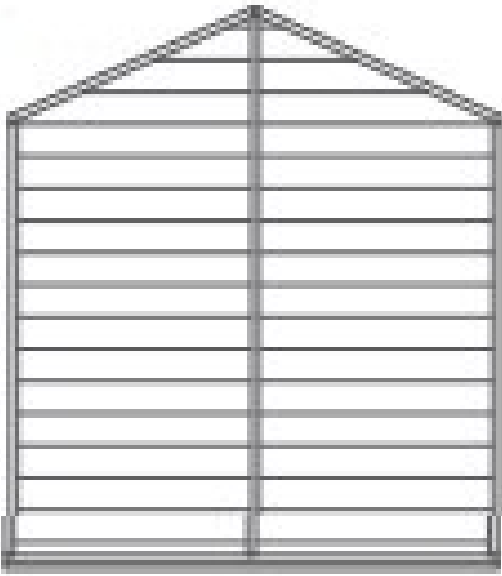

3. Plain Side QTY 2

(QTY 4 NW ONLY)

AI-01OVLPPS1490X1567-V1



4. Window Panel QTY 2

(FW ONLY)

AI-01OVL PWS1490X1567-V

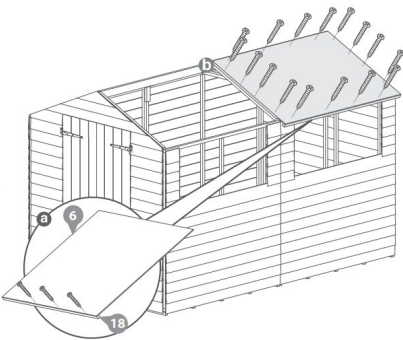

5. Floor

QTY 2

AI-01OVL PF1753X1487-V1

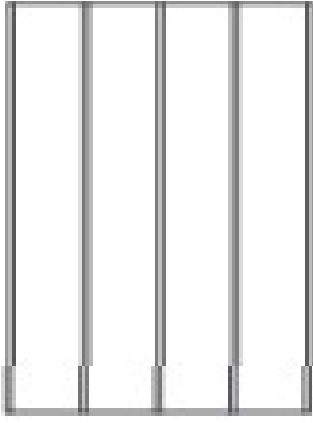

6. **Roof**

QTY 4

PI-03-0247



7. **Door**

QTY 2

AI-01MBDR1660X439-V1

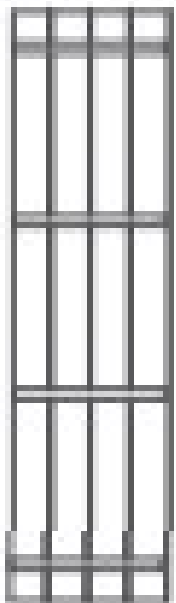

8. **Ridge Bar** – 27x70x1462mm

QTY 2

F2770-1462mm



9. **Truss Frame** – 27x44x972mm

QTY 2

F2744-972mm



10. **Door Block** – 28x28x140mm

QTY 2

F2828-140mm



11. **Truss Block** – 27x44x140mm

QTY 2

F2744-160mm (140mm finished length)



12. **Truss Support** – 27x44x450mm

QTY 1

F2744-490mm (450mm finished length)



13. **Fascia** -12x60x1016mm

QTY 4

S1260-1016mm



14. **Door Strip** – 12x60x1016mm

QTY 1

S1260-1016mm



15. **Door Strip** – 12x60x530mm

QTY 1

S1260-530mm



16. **Cover Trim** – 12x45x1575mm

QTY 6

S1245-1575mm



17. **Door Beading Strip** – 12x28x1590mm

QTY 2

S1228-1590mm



18. **Eaves Frame** – 28x28x1502mm

QTY 4

F2828-1502mm



19. **Window Strip** – 12x30x546mm

QTY 10 (FW ONLY)

S1230-546mm

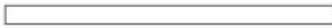

20. **Finial**

QTY 2

Diamond Shed Finial



21. **Felt**



22. **T Hinge**

QTY 4

PI-02-1043

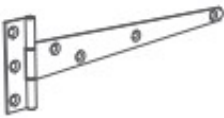

23. **L-Bracket**

QTY 2

PI-07-0012

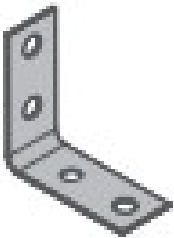

24. **Turn Button**

QTY 3

PI-07-0034

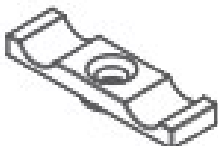

25. **Plastic Window Cill**

QTY 2 (FW ONLY)

PI-08-0013



26. U Channel

QTY 1

PI-07-0013

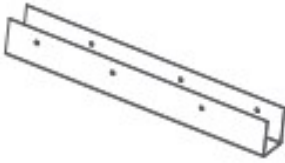

27. Styrene

QTY 4 (FW ONLY)

PI-05-01

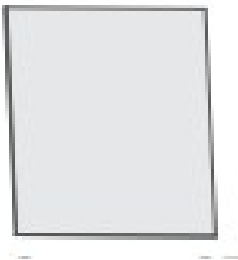

Nail Bag

- 40mm Screw x 116

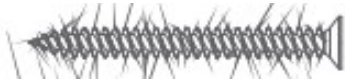

- 50mm Screw x 28

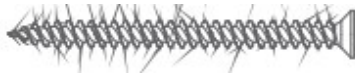

- 70mm Screw x 24



- Felt Tacks x 120



- 30mm Screw x 76



- 30mm Black Screw x 3



Pre Assembly

Remove transportation blocks from the bottom of each panel before beginning assembly. Each Panel should have

two blocks.

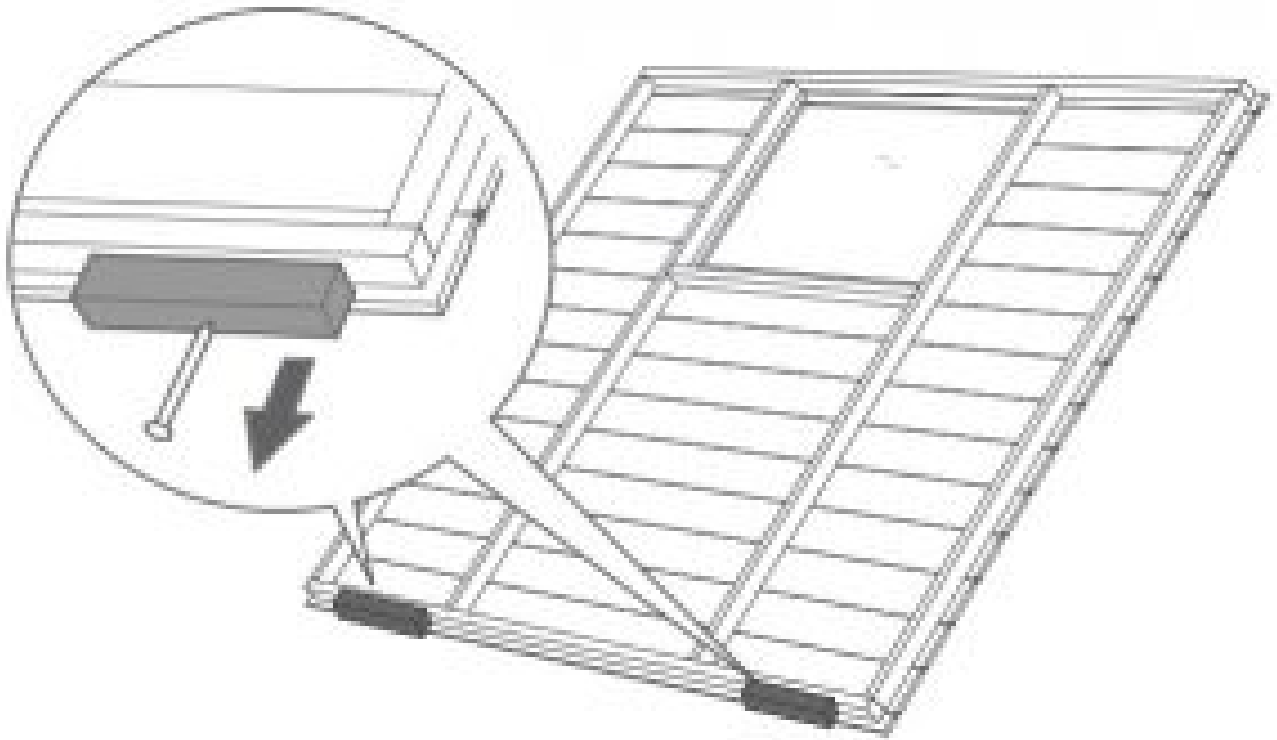

Fix the T Hinges onto the doors and door frame as shown. Ensure that the screws go through the cladding and into the framing behind.

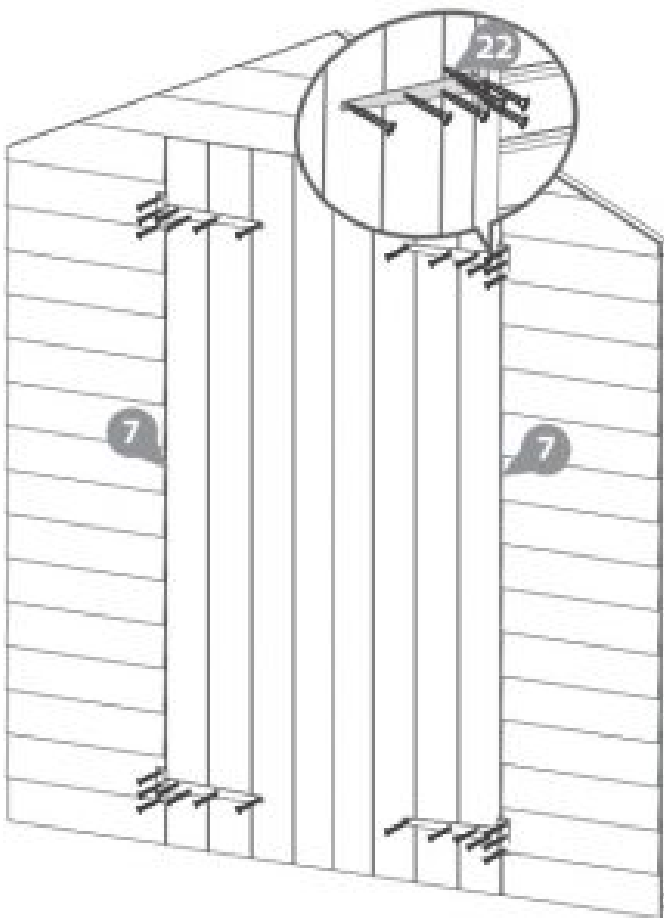

28x30mm screws



Step 1

Place floor on firm and level base, ensure base has suitable drainage free from areas where water can collect. (See front page on base requirements).

Attach the floors using 12 x 40mm screws

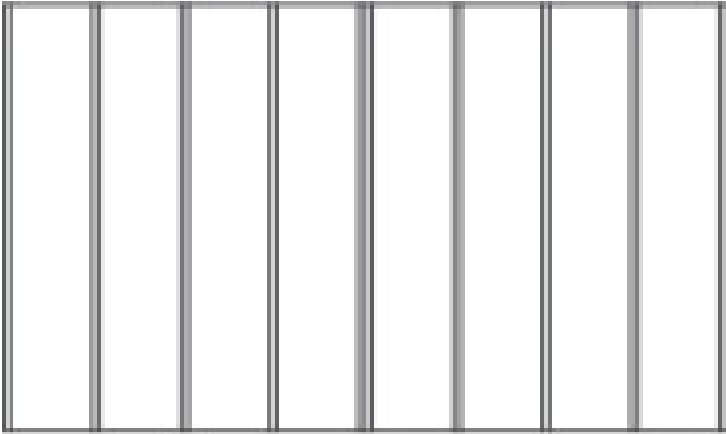

12x40mm screws

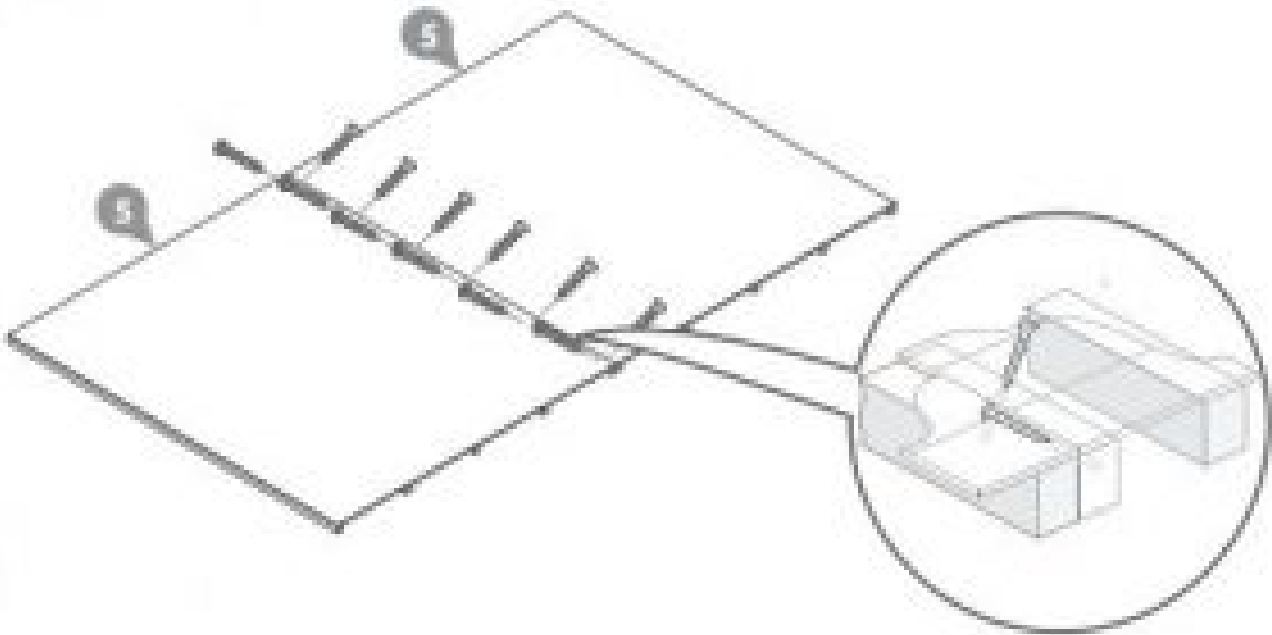

Step 2

Fix the corners with 50mm screws as shown in diagram.

Do not secure the building to the floor until the roof is fitted. Fix the panels onto the floor using 50mm screws in alignment with the floor joists

Position the panels so there is equal spacing between the floor and cladding on all 4 sides

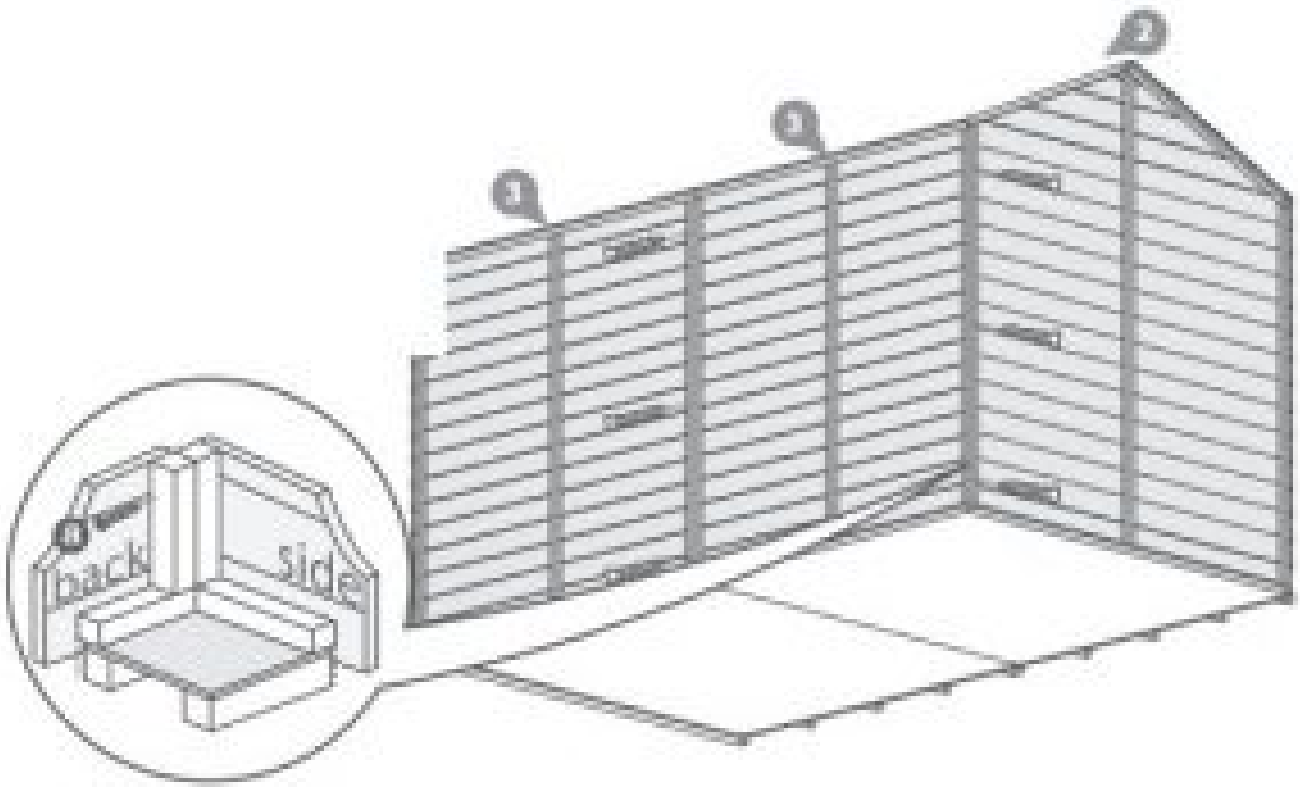

6x50mm Screws



Step 3

Fix the corners with 50mm screws as shown in diagram.

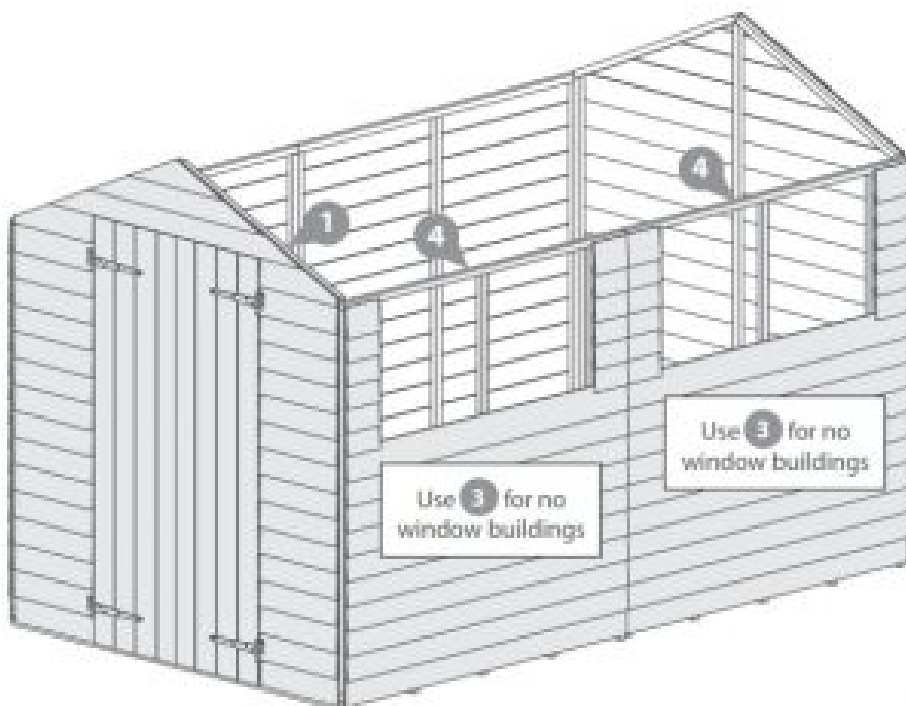

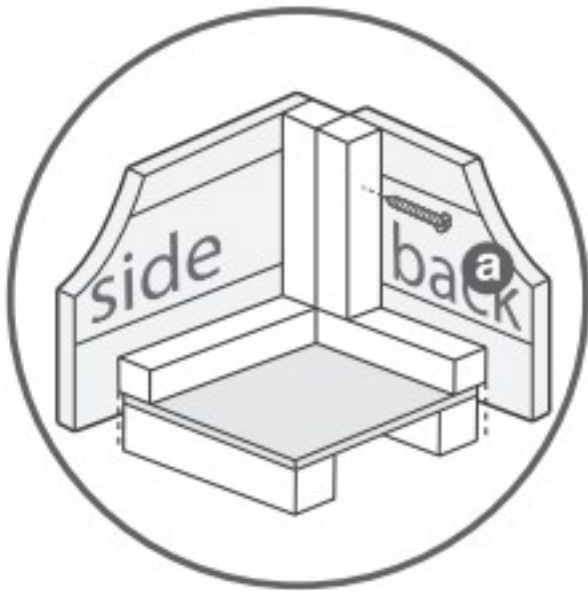

12x50mm Screws



Step 4

Ridge Bar Assembly

Position the two parts of the ridge bar within the `U' channel and secure from either side with 3 x 30mm screws and 4 x 30mm screws from underneath. Secure an `L' bracket to either end of the ridge bar using 2 x 30mm screws per bracket.

Place the roof support bar in between the front and back panels. Ensure the top corners of the support bar are flush with each top point. Secure in place using the L Bracket on each end with 4x30mm screws.

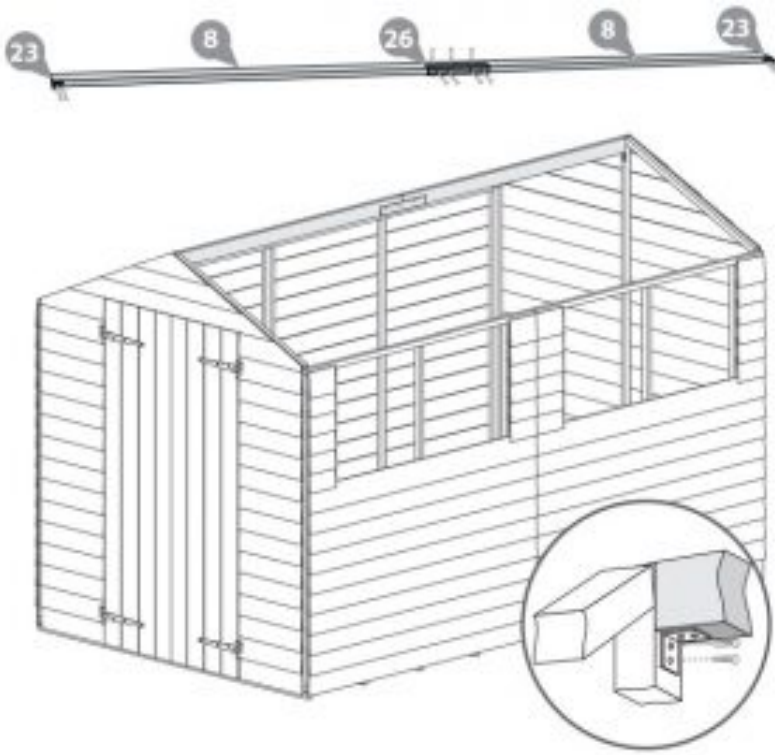

18x30mm Screws



Step 5

1. Position a truss frame to the ridge bar sloping down towards the building side, ensure it is central to the middle upright of the panel. Fix with a 50mm screw through the ridge bar into the truss frame.
2. Align the second truss frame with the first on the opposite side of the ridge bar and fix with a 50mm screw at an angle as illustrated

ENSURE SUPPORT BARS ARE MANUALLY SUPPORTED UNTIL FIXED AT BOTH ENDS

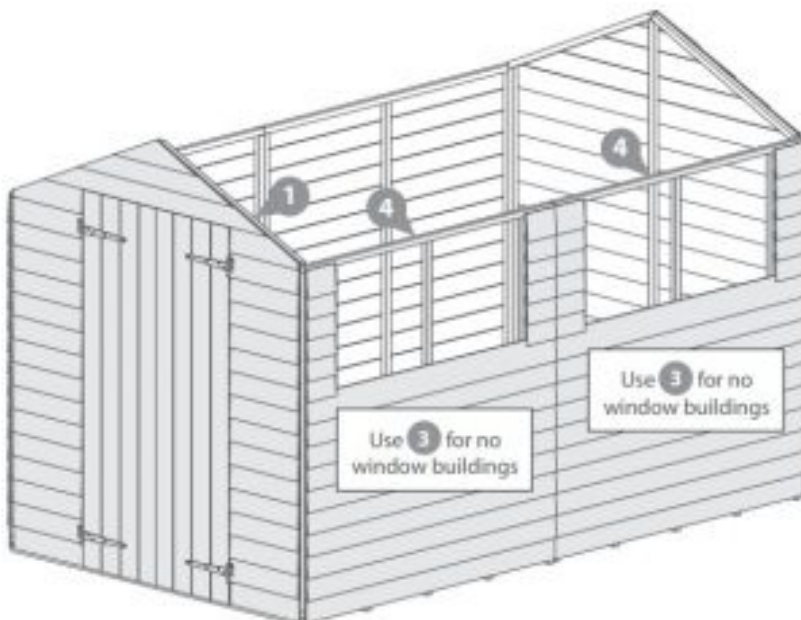

4x50mm Screws

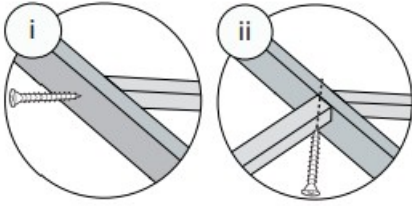

Step 6

Fix the truss block to the side panel framing with 2 x 50mm screws. Position the block at the top of the framing with the angle pointing upwards into the building, aligning the block centrally along the join between the side panels with one screw in each panel. ii) Fix the support bar to the block using 1 x 50mm screw.

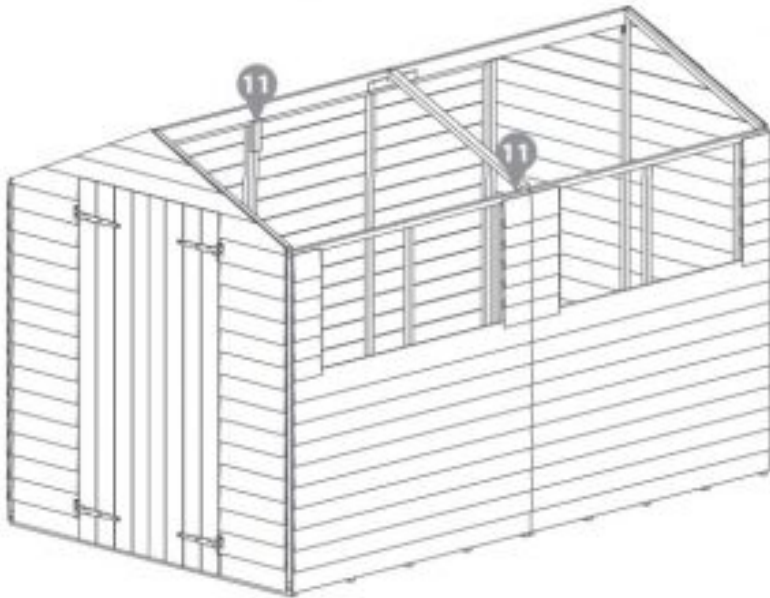

6x50mm Screws



Step 7

Fix a Truss support between the two truss frames and fix in place using 40mm screws, ensure you pre-drill holes before fixing together.

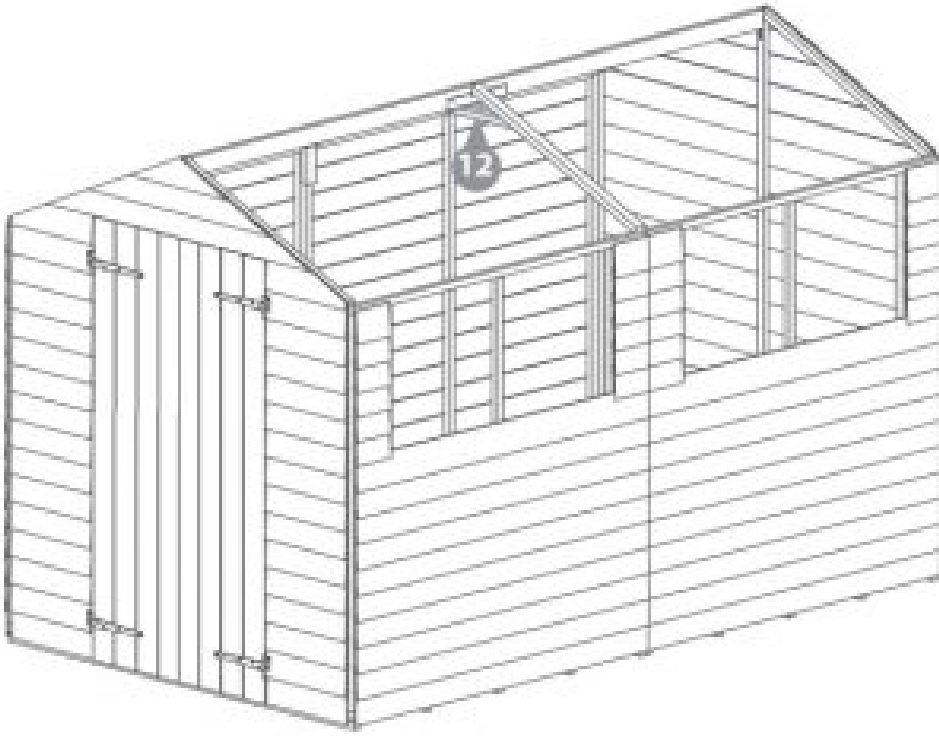

4x40mm Screws

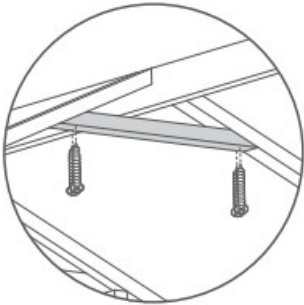

Step 8

1. Fix the eaves frame to the roof sheet using 3x30mm screws for each sheet 8x30mm Screws
2. Place two roof sheets on top of the plain gable and truss. Before fixing the roof sheet to the truss frame make sure the edge of the roof sheet sits in the middle of the truss frame then fix using 40mm screws.

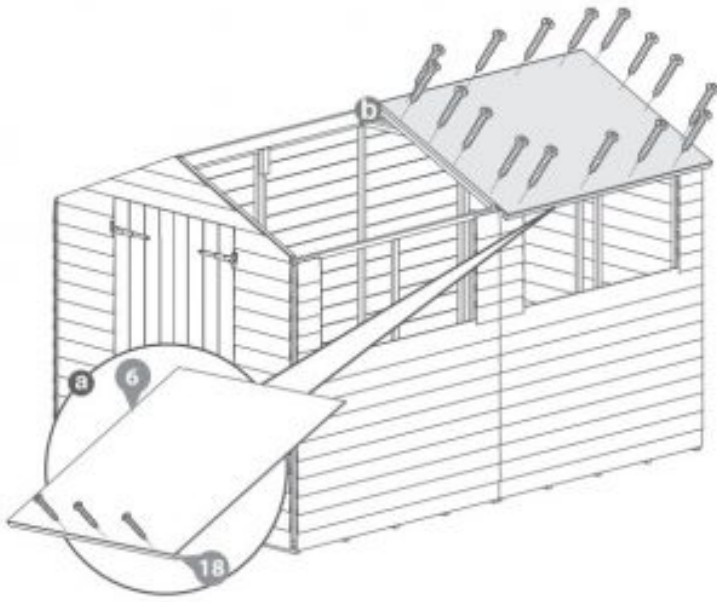

32x40mm Screws



Step 9

1. Fix the eaves frame to the roof sheet using 3x30mm screws for each sheet. 8x30mm Screws
2. Place two roof sheets on top of the plain gable and truss. Before fixing the roof sheet to the truss frame make sure the edge of the roof sheet sits in the middle of the truss frame then fix using 40mm screws.

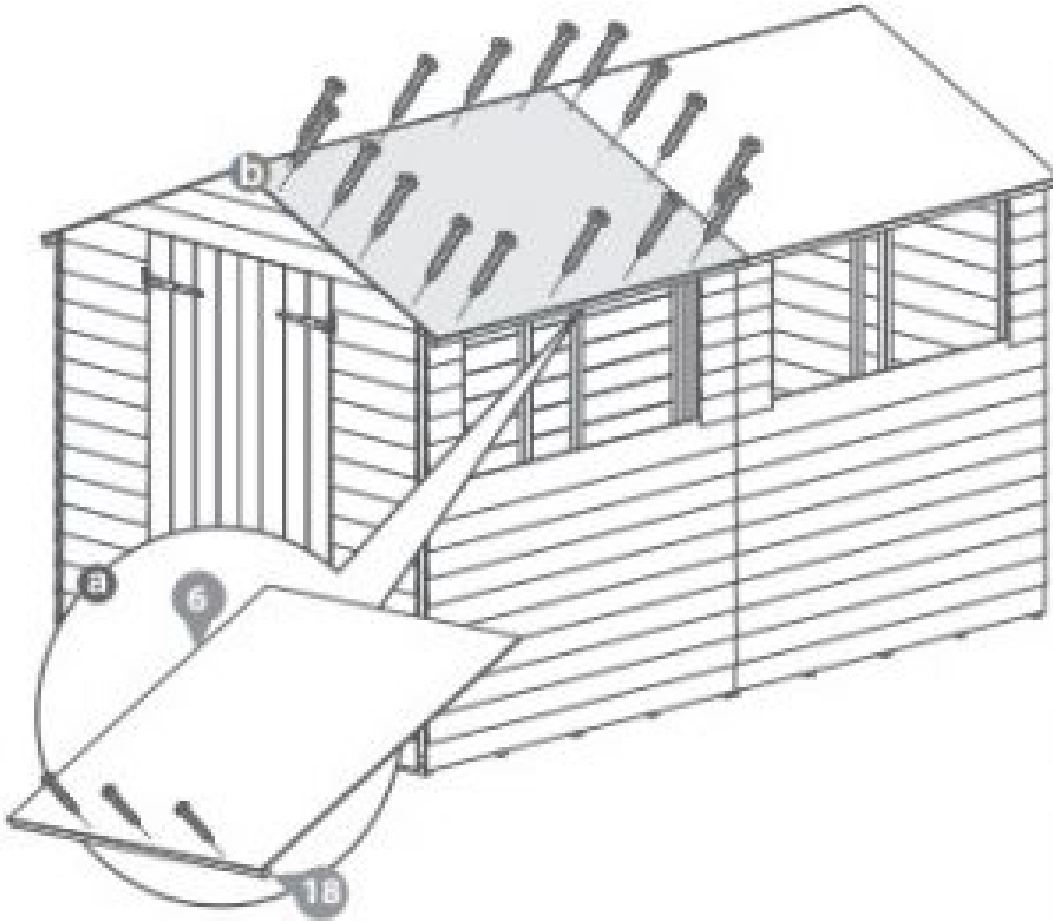

32x40mm Screws



Step 10

Once the roof is fixed attach the building to the oor with 70 mm screws.

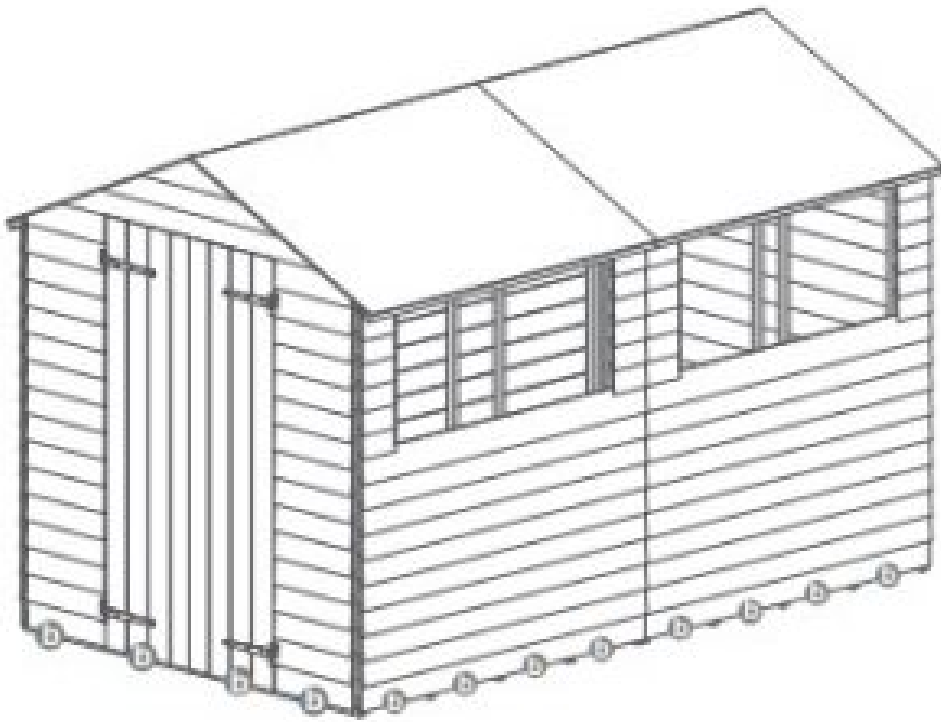

24 x 70mm Screw

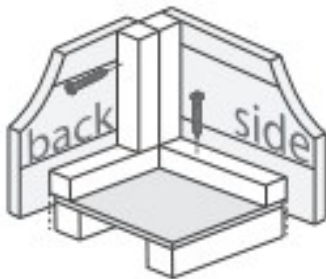

Step 11

Cut out three strips of 3104mm felt and place onto the roof. Place the felt at onto the roof in the order that is stated on the diagram below. Once the sheets are laid out fix them onto the roof with tacks 100mm apart.

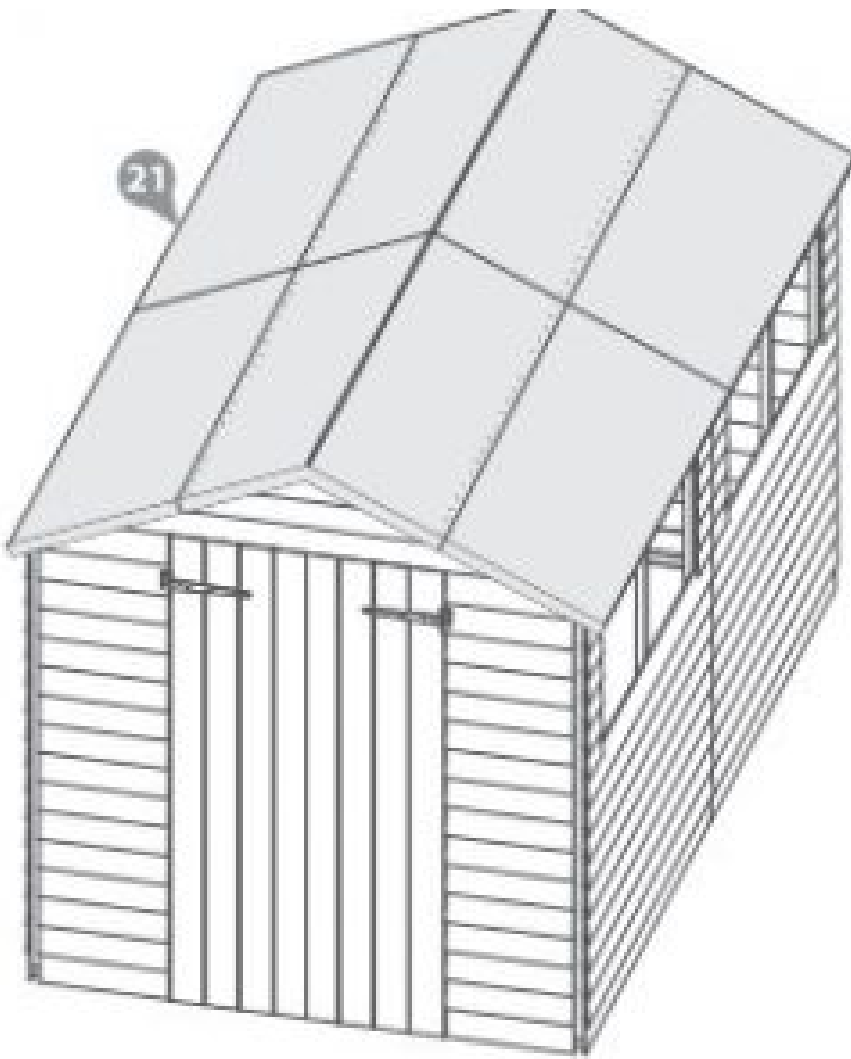

120 x Tacks



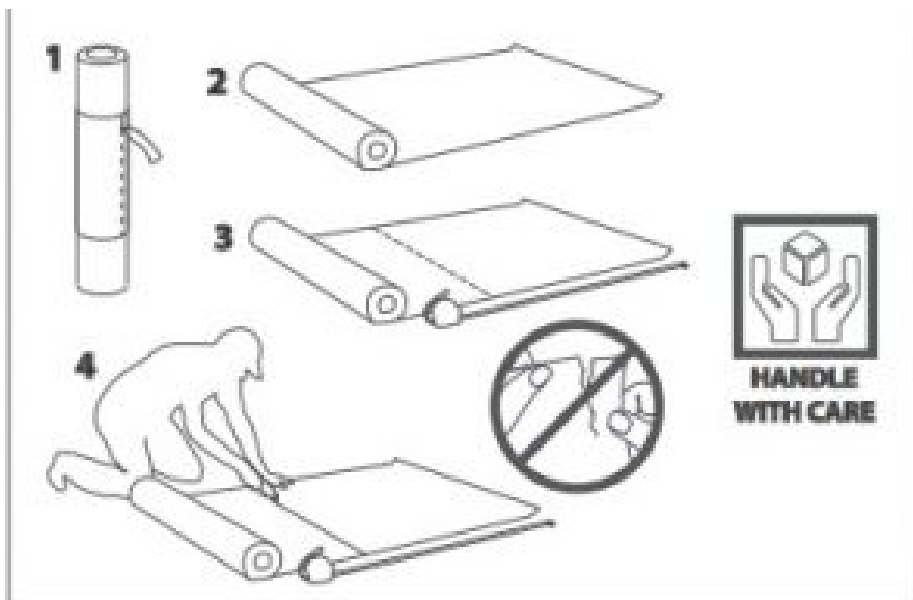

Step 12

1. First line up the door blocks at the top and bottom of the doors. Then fix with 2x30mm screws by screwing through the outside of the door into the block 4x30mm Screws
2. Use 4x30mm Screws to fix each beading strip onto the door gable. Ensure that the screw is parallel with the door frame when fixing the strip to the door gable as shown in the close up view 8x30mm Screws
3. Attach the turn button to the top and bottom door blocks with 1x30mm screw for each one. 2x30mm Black Screws



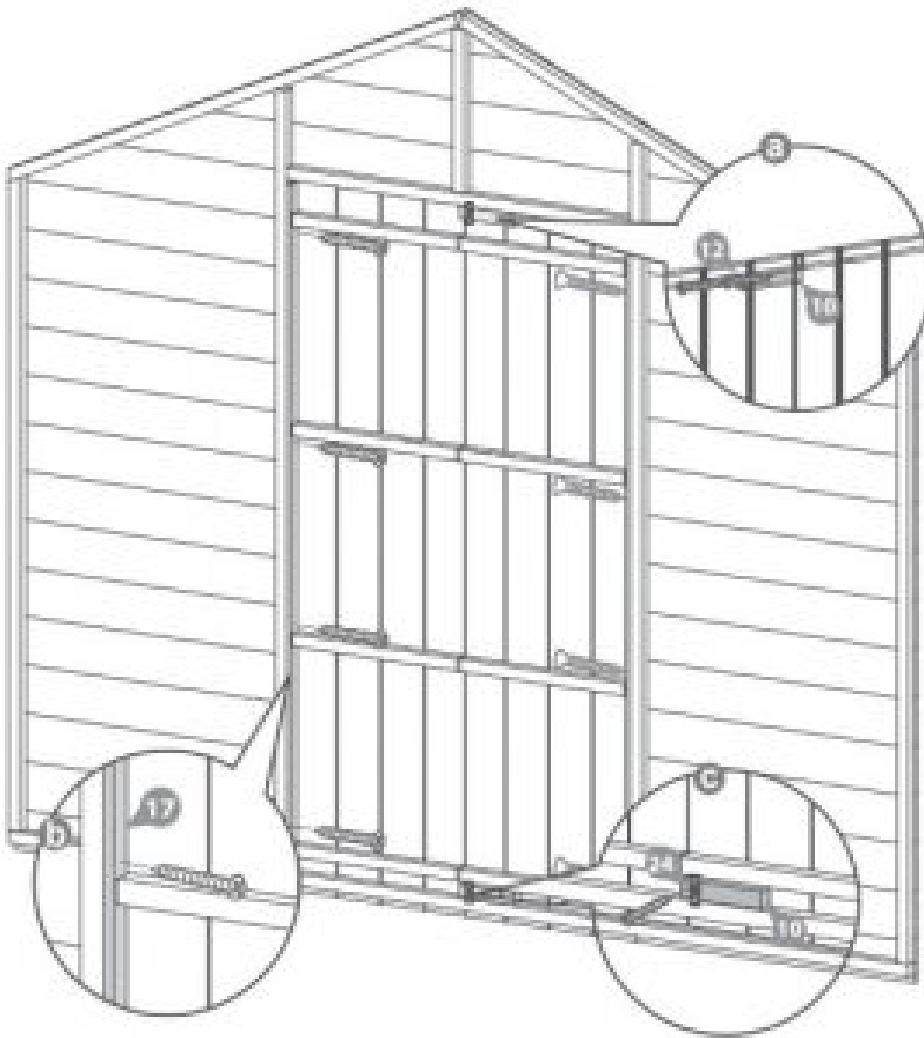

Step 13

Fit the cover trims to the building and secure in place with 40mm screws as shown. Pre drill to avoid splitting
18x40mm Screws

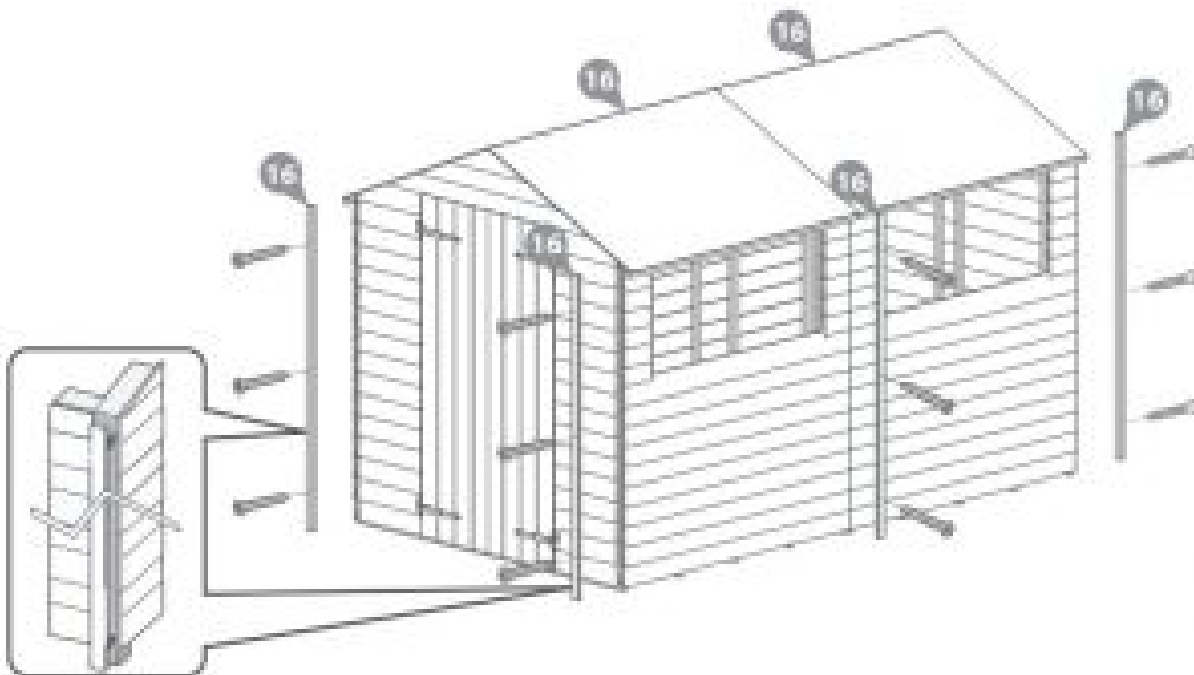

18x40mm Screws



Step 14

Attach fascias to the roof leaving a slight overhang at the top. Fit the fascias to the roof over the felt and secure in place with 40mm screws as shown. Pre drill to avoid splitting 16x40mm Screws

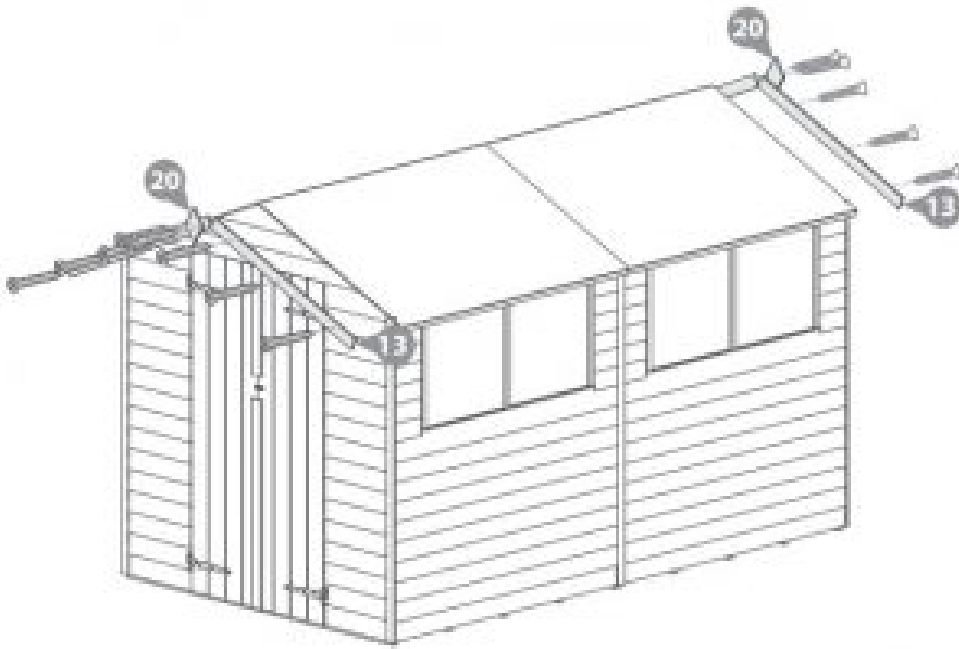

16x40mm Screws



Step 15

1. a Fix the door strips to the master door using 5x30mm screws. If the strips are attached to the slave door the doors will not open properly. 5x30mm Screws
2. Use 1x30mm screw to secure the turn button to the master door. 1x30mm Black Screws



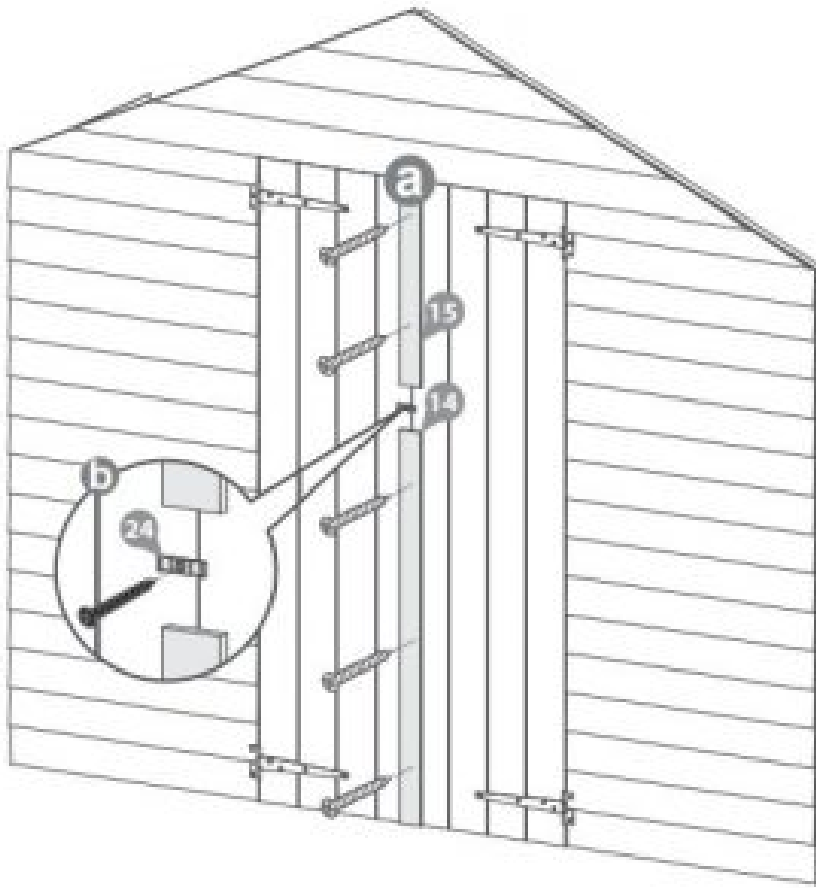

Step 16

For the no window version go to step 11

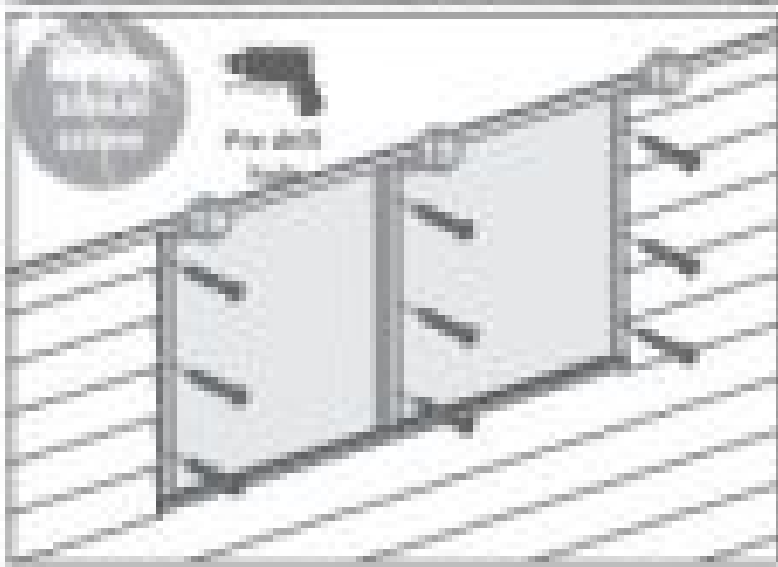
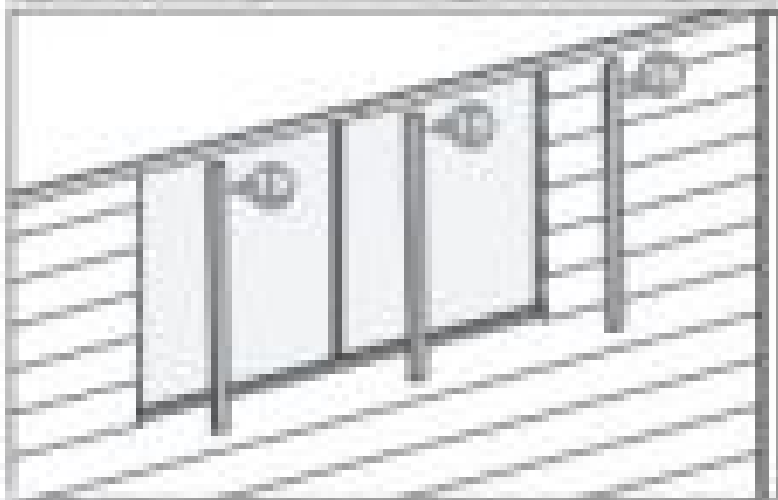
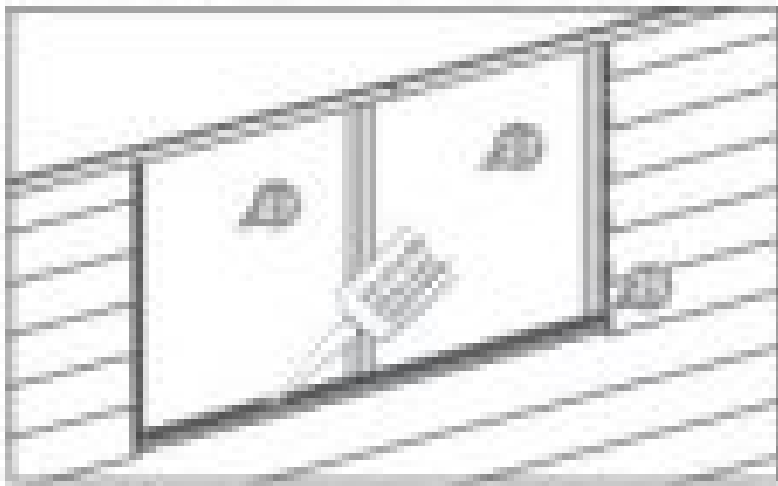
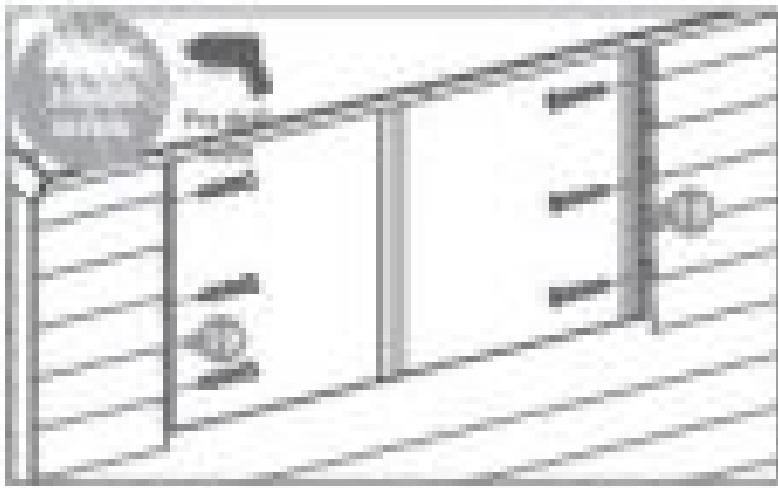

Fix the window strips to the two pieces of framing that sit alongside the outside edges of the window with 3x30mm screws for each strip.

6x30mm Screws



Place the plastic window cill onto the Window Panel and silicone in place as shown on both diagrams to the left. Fit the styrene sheets on top of the window cill. When positioning the styrene sheets ensure there is an equal distance between them and at either side of the windows.

Attach the three window strips at either side of the windows using 3x30mm screws each. Make sure the screws enter the framing in the window panel and not the styrene.

9x30mm Screws

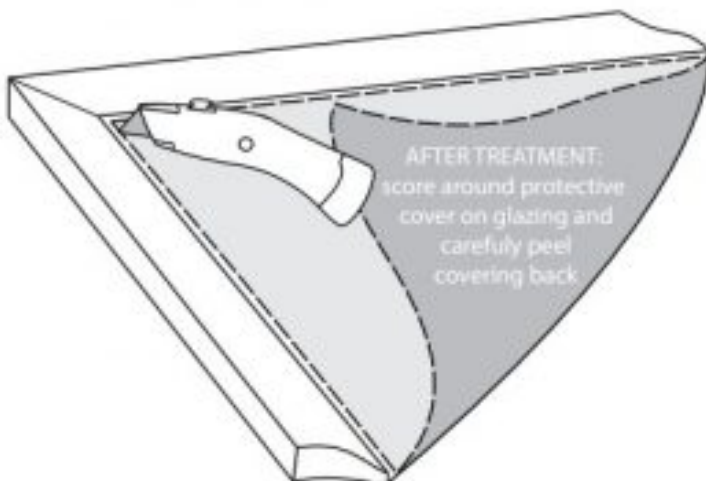

Documents / Resources



[Mercia Garden Overlap Apex](#) [pdf] Instructions
Overlap Apex, 01OVLPA1006DDFW-V1, 01OVLPA1006DDFW-V1-NW

References

-  [Mercia Garden Products – MerciaGardenProductsLtd](#)

[Manuals+](#)