



RCP-1U Rack  
System  
Distributed  
Power System



# MEAN WELL RCP-1U Rack System 1000 – 3000W 1U Distributed Power System Owner's Manual

[Home](#) » [MEAN WELL](#) » MEAN WELL RCP-1U Rack System 1000 – 3000W 1U Distributed Power System Owner's Manual 

## Contents

- [1 MEAN WELL RCP-1U Rack System 1000 – 3000W 1U Distributed Power System](#)
- [2 Features](#)
- [3 Applications](#)
- [4 SPECIFICATION – Power Supply System](#)
- [5 Documents / Resources](#)
  - [5.1 References](#)
- [6 Related Posts](#)



**MEAN WELL RCP-1U Rack System 1000 – 3000W 1U Distributed Power System**



## Features

- Universal AC input / Full range
- 1U profile 19" rack shelf, fitting three 1000W modules up to 3000W with active current sharing
- Output voltage programmable
- Support hot swap (hot plug)
- 5 years warranty

## Applications

- Industrial automation
- Distributed power architecture system
- Wireless/telecommunication solution
- Redundant power system
- Electric vehicle charger system
- Constant current source system

## GTIN CODE

- MW Search: <https://www.meanwell.com/serviceGTIN.aspx>

## Description

RCP-1U rack system is a power distribution solution utilizing the rack configuration with 1U low profile. Starting with a single unit of 1000W, RCP-1000 is the front end rectifier (or, power supply). With the active current sharing function, up to 3000W is able to be provided by 1 stack of the 19" rack mountable shelf RCP-1U and 8000W by 3 stacks. The design flexibility for system applications is ideally fulfilled by various in features, such as output programming, remote ON-OFF, auxiliary power, etc.

## Model Encoding/Order Information

### Rack Shelf:

RCP-1U I

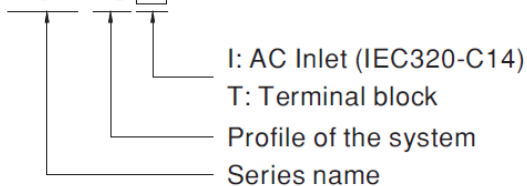

### Whole System:

RCP-3K1U I-12-C

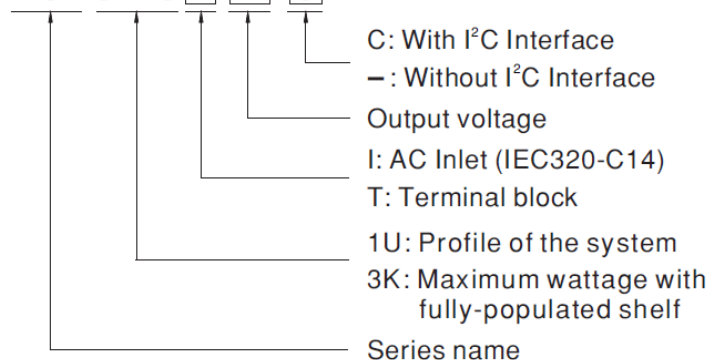

## SPECIFICATION – Power Supply System

MODEL	RCP-3K1U□-12	RCP-3K1U□-24	RCP-3K1U□-48
RECTIFIER	RCP-1000-12	RCP-1000-24	RCP-1000-48

OUTPUT	RACK SHELF	RCP-1UI or RCP-1UT					
	OUTPUT VOLTAGE	12V		24V		48V	
	MAX. OUTPUT CURRENT	180A		120A		63A	
	MAX. OUTPUT POWER Note.5	2160W		2880W		3024W	
INPUT	VOLTAGE RANGE Note.4	90 ~ 264 VAC	127 ~ 370VDC				
	FREQUENCY RANGE	47 ~ 63Hz					
	AC CURRENT (Typ.)PER MODULE	8.5A/115 VAC	4.5A/230 VAC		10.5A/115VAC	5.5A/230VAC	11A/115 VAC 5.5A/230VAC
	LEAKAGE CURRENT	<3.5mA / 230VAC					
FUNCTION	AUXILIARY POWER	5V @ 0.3A					
	REMOTE ON-OFF CONTROL	By electrical signal or dry contact ON:short OFF:open					
	REMOTE SENSE	Compensate voltage drop on the load wiring up to 0.5V.					
	OUTPUT VOLTAGE PROGRAMMABLE	Adjustment of output voltage is allowable to 90 ~ 110% of nominal output voltage. Please refer to the Function Manual.					
	DC OK SIGNAL	The isolated TTL signal out, Please refer to the Installation Manual					
	AC OK SIGNAL	The isolated TTL signal out, Please refer to the Installation Manual					
	OVER TEMP WARNING	Logic " High" for over temperature warning, Please refer to the Installation Manual, isolated signal					
ENVIRONMENT	WORKING TEMP.	-20 ~ +60°C (Refer to "Derating Curve")					
	WORKING HUMIDITY	20 ~ 90% RH non-condensing					
	STORAGE TEMP., HUMIDITY	-40 ~ +85°C, 10 ~ 95% RH non-condensing					
	TEMP. COEFFICIENT	±0.02%/°C (0 ~ 50°C)					
	VIBRATION	10 ~ 500Hz, 2G 10min./1cycle, 60min. each along X, Y, Z axes					
SAFETY STANDARDS	UL62368-1, CSA C22.2 No. 62368-1, TUV BS EN/EN62368-1, EAC TP TC 004 approved						
	WITHSTAND VOLTAGE	I/P-O/P:3 KVAC	I/P-FG:2 KVAC	O/P-FG:0.7KV DC			

<b>SAFE TY &amp; EMC</b>  (Note 6)	<b>ISOLATION RESI STANCE</b>	I/P-O/P, I/P-FG, O/P-FG:100M Ohms / 500VDC / 25°C/ 70% RH		
	<b>EMC EMISSION</b>	<b>Parameter</b>	<b>Standard</b>	<b>Test Level / Note</b>
		Conducted	BS EN/EN55032 (CISPR 32)	Class B
		Radiated	BS EN/EN55032 (CISPR 32)	Class B
		Harmonic Current	BS EN/EN61000-3-2	—
		Voltage Flicker	BS EN/EN61000-3-3	—
	<b>EMC IMMUNITY</b>	BS EN/EN55035, BS EN/EN61000-6-2		
		<b>Parameter</b>	<b>Standard</b>	<b>Test Level / Note</b>
		ESD	BS EN/EN61000-4-2	Level 3, 8KV air ; Level 2, 4KV contact
		Radiated	BS EN/EN61000-4-3	Level 3
EFT / Burst		BS EN/EN61000-4-4	Level 3	
Surge		BS EN/EN61000-4-5	Level 4, 4KV/Line-Earth ; Level 3, 2KV/Line-Line	
Conducted		BS EN/EN61000-4-6	Level 3	
Magnetic Field		BS EN/EN61000-4-8	Level 4	
Voltage Dips and Interruptions		BS EN/EN61000-4-11	>95% dip 0.5 periods, 30 % dip 25 periods, >95% interruptions 250 p eriods	
<b>OTHE RS</b>	<b>DIMENSION</b>	Rack 350.8*483.6*44(L*W*H)		
	<b>PACKING</b>	13.2Kg; 1pcs/13.2Kg/2.67CUFT		

**NOTE**

1 All parameters NOT specially mentioned are measured at 230VAC input, rated load and 25°C of ambient temperature

2 Ripple & noise are measured at 20MHz of bandwidth by using a 12" twisted pair-wire terminated with a 0.1uf & 47uf parallel capacitor Under parallel operation of more than one rack connecting together, ripple of the output voltage may be higher than the SPEC at light load condition It will go back to normal ripple level once the output load is more than 10%

3 Tolerance : includes set up tolerance, line regulation and load regulation

4 Derating may be needed under low input voltages Please check the derating curve for more details 5 Output of all the RCP-1000 modules are connected in parallel in the rack

6 The power supply is considered a component which will be installed into a final equipment All the EMC tests are been executed by mounting the unit on a 720mm\*360mm metal plate with 1mm of thickness The final equipment must be re-confirmed that it still meets EMC directives For guidance on how to perform these EMC tests, please refer to "EMI testing of component power supplies "

(as available on [https://www.meanwell.com//Upload/PDF/EMI\\_statement\\_en.pdf](https://www.meanwell.com//Upload/PDF/EMI_statement_en.pdf))

7 The ambient temperature derating of 3.5°C/1000m with fanless models and of 5°C/1000m with fan models for operating altitude higher than 2000m(6500ft)

\* Product Liability Disclaimer For detailed information, please refer to <https://www.meanwell.com/serviceDisclaimer.aspx>

**Function Manual**

**1. Remote ON/OFF Control**

The PSU can be turned ON/OFF together or separately by using the "Remote ON-OFF" function.

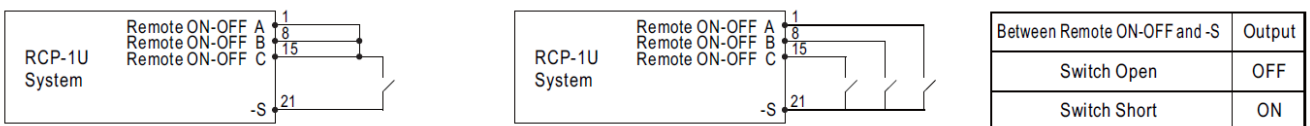

**2. Voltage Drop Compensation**

**1. Remote Sense**

The remote sense compensates voltage drop on the load wiring up to 0.5V.

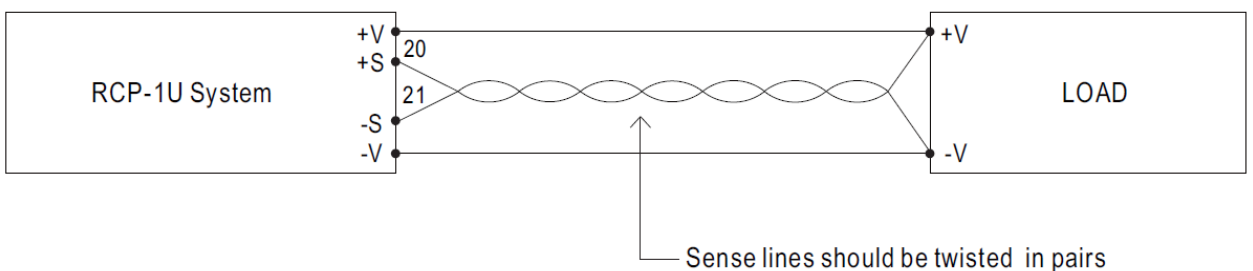

**2. Local Sense**

**Notice:** The +S,-S, on CN500 have to be connected to the +V,-V terminals locally in order to get the correct output voltage if the remote sensing is not used.

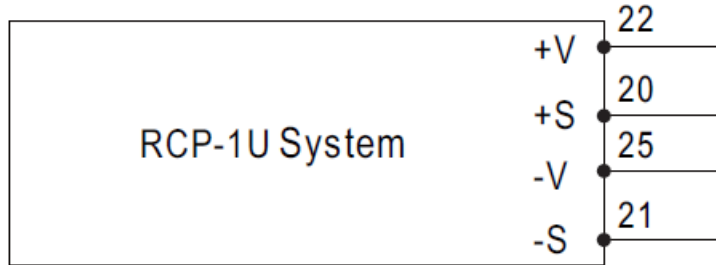

3. Output Voltage Programming (or, PV / remote voltage programming / remote adjust / margin programming / dynamic voltage trim)

1. Output voltage can be trimmed between 90~110% of its rated value by the following method.
2. +S & +V, -S & -V also need to be connected on CN500.

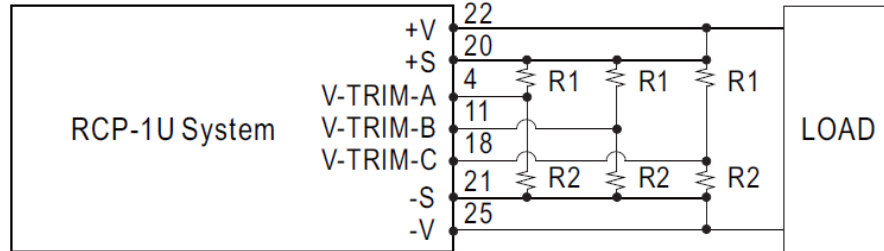

**RCP-1000-12**

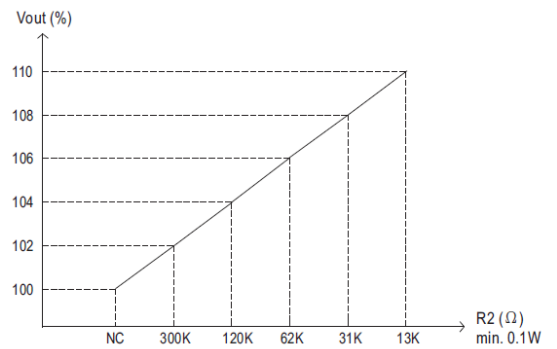
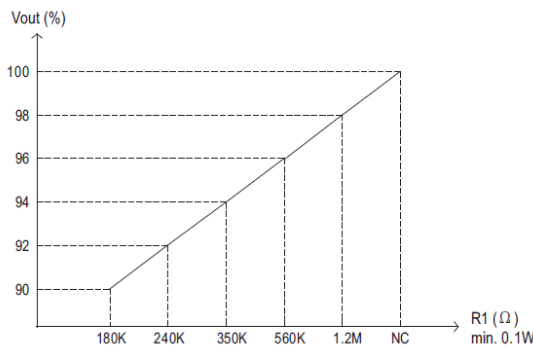

**RCP-1000-24**

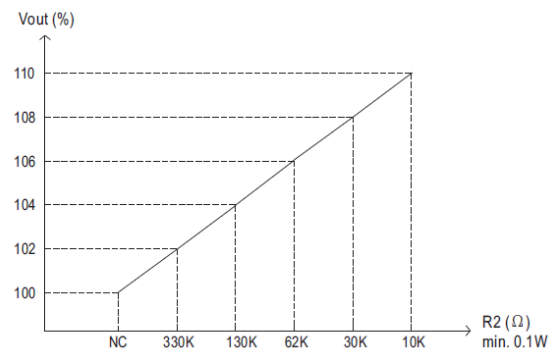
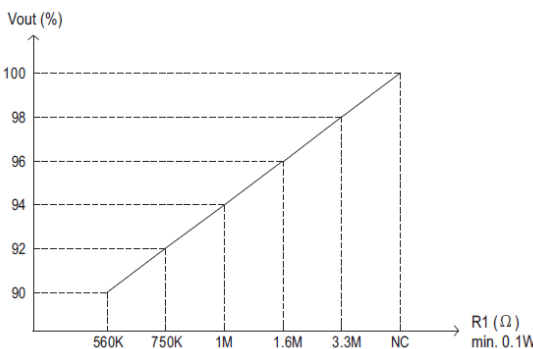

**RCP-1000-48**

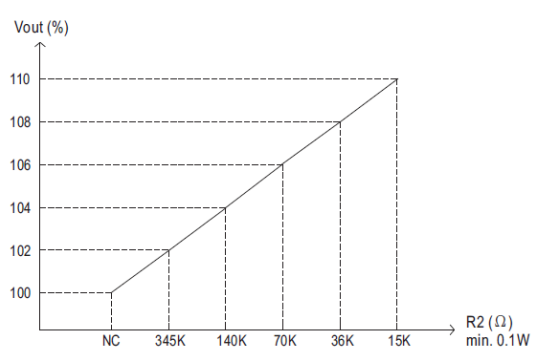
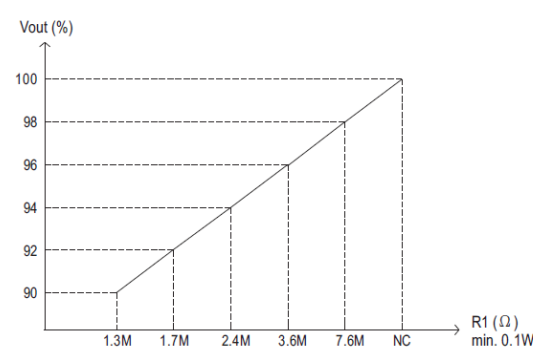

## 4. I C Bus Interface 2

For the details of I C bus used on this product, please refer to the Installation Manual.

### Mechanical Specification (Rack System)

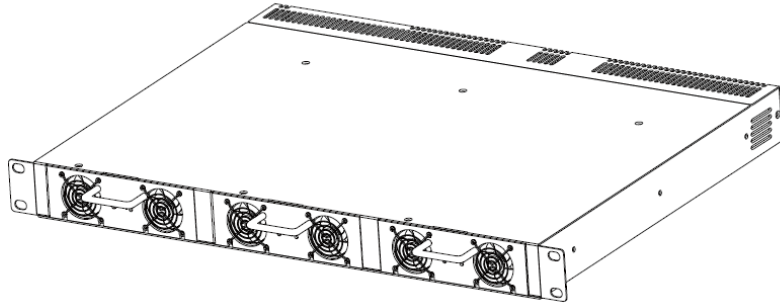
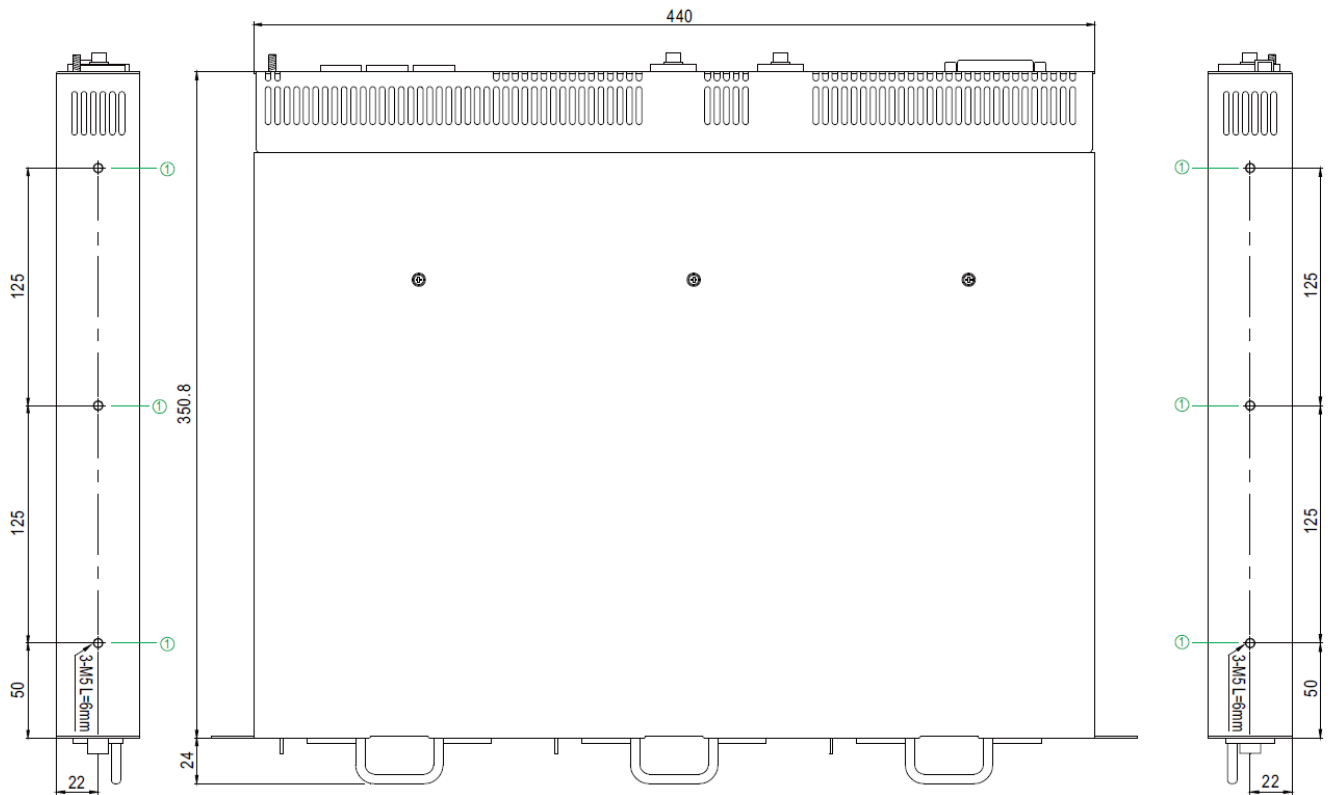
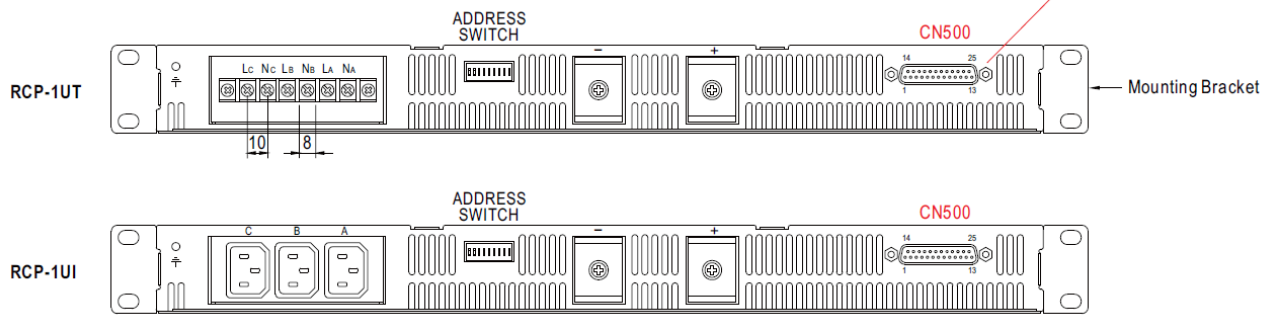
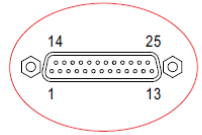
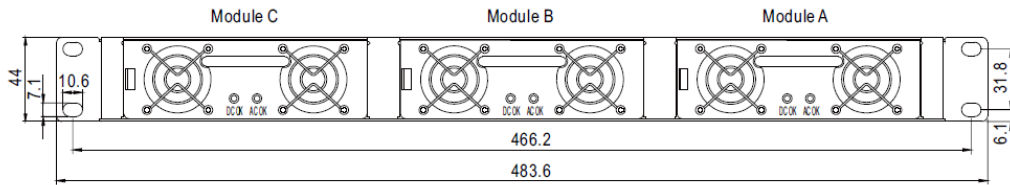

Fig1



↑ Air flow direction



※ Mounting Instruction

Hole No.	Recommended Screw Size	MAX. Penetration Depth L	Recommended mounting torque
①	M5	6mm	10Kgf-cm

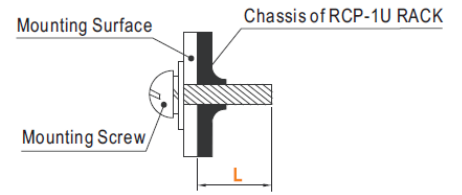

IN/OUT Connector Pin No. Assignment(CN500) : D-Type Right Angle 25 positions(female type)

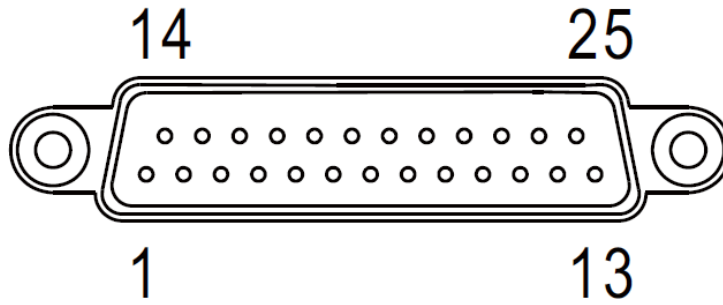



Pin No.	Function	Description
1,8,15	Remote ON-OFF	Each unit can separately turn the output on and off by electrical or dry contact between Remote ON-OFF A,B,C(pin 1,8,15) and -S(pin 21). Short: ON, Open:OFF.
2,9,16	AC-OK	Low : When input voltage is $\geq 82V_{rms} \pm 4V$ . High : When input voltage in $\leq 82V_{rms} \pm 4V$ .
3,10,17	DC-OK	High : When $V_{out} \leq 80\% \pm 5\%$ . Low : When $V_{out} \geq 80\% \pm 5\%$
4,11,18	V-TRIM	Connection for output voltage programming.
5,12,19	T-ALARM	High : When the internal temperature is within safe limit. Low : 10°C below the thermal shutdown limit.
6	+5V-AUX	Auxiliary voltage output, 4.3~5.3V, referenced to GND-AUX(pin 7). The maximum load current is 0.3A. This output has the built-in "Oring diodes" and is not controlled by the remote ON/OFF control.
7	GND-AUX	Auxiliary voltage output GND. The signal return is isolated from the output terminals (+V & -V).
14	CS	Current sharing signal. When units are connected in parallel, the CS pins of the units should be connected to allow current balance between units.
20	+S	Positive sensing for Remote Sense.
21	-S	Negative sensing for Remote Sense.
22	+V	Positive output voltage.
23	SCL	2 Serial clock used in the I C interface option. Refer to the Instruction Manual.
24	SDA	2 Serial data used in the I C interface option. Refer to the Instruction Manual.
25	-V	Negative output voltage.

File Name:RCP-1U Rack System-SPEC 2024-01-26.

## Documents / Resources



[MEAN WELL RCP-1U Rack System 1000 - 3000W 1U Distributed Power System](#) [pdf] Owner's Manual  
RCP-3K1U-12, RCP-3K1U-24, RCP-3K1U-48, RCP-1000-12, RCP-1000-24, RCP-1000-48, RCP-1U Rack System 1000 3000W 1U Distributed Power System, RCP-1U Rack System, 1000 3000W 1U Distributed Power System, 1U Distributed Power System, Distributed Power System, Power System, System

## References

- [TÜV Rheinland - Home | US | TÜV Rheinland](#)
- [User Manual](#)

[Manuals+](#), [Privacy Policy](#)

This website is an independent publication and is neither affiliated with nor endorsed by any of the trademark owners. The "Bluetooth®" word mark and logos are registered trademarks owned by Bluetooth SIG, Inc. The "Wi-Fi®" word mark and logos are registered trademarks owned by the Wi-Fi Alliance. Any use of these marks on this website does not imply any affiliation with or endorsement.