

G Series

TRAFFIC BEACON USER MANUAL

For the SC315-G, R820-G, R829-G, and R247-G flashing beacons



87667_MANUAL_TRA_G-Series_RevC



Table of Contents

| | |
|--|-----------|
| 1.0 Warnings and Precautions | 4 |
| 1.1 Warranty Disclaimer | 4 |
| 1.2 Standards | 4 |
| 1.3 Safety and Usage Precautions | 4 |
| 1.4 System Components | 6 |
| 2.0 Introduction..... | 7 |
| 2.1 About the G Series | 7 |
| 2.2 Ambient Brightness Sensor | 9 |
| 2.3 Radio Communication | 9 |
| 2.4 Label Explanation | 10 |
| 2.5 SC315-G: Pedestrian Crosswalk with RRFB Light Bars | 11 |
| 2.6 R820-G: Pedestrian Crosswalk with Circular Beacons | 13 |
| 2.7 R829-G: School Zone Flashing Beacon | 14 |
| 2.8 R247-G: 24-Hour Flashing Beacon | 15 |
| 2.9 RRFB Light Bars: Overview..... | 16 |
| 2.10 Circular Beacons: Overview | 17 |
| 2.11 LED Enhanced Signs: Overview | 18 |
| 2.12 Alternating Three Beacon Setup | 19 |
| 2.13 Multiple Steady-On Loads | 20 |
| 2.14 Third-Party Devices: Overview | 21 |
| 3.0 Solar Panel and Cabinet Installation | 22 |
| 3.1 Tools and Materials Required..... | 22 |
| 3.2 Pole Preparation | 22 |
| 3.3 Solar Panel Installation | 22 |
| 3.4 Cabinet Installation | 32 |
| 3.5 Overview of Cabinet Terminals..... | 34 |
| 3.6 Installation of Cabinet Terminals | 38 |
| 4.0 Fixture and Push Button Installation..... | 41 |
| 4.1 RRFB Light Bar Installation | 41 |
| 4.2 Circular Beacon Installation..... | 46 |
| 4.3 LED Enhanced Sign Installation | 47 |
| 4.4 Push Button Installation..... | 51 |
| 4.5 Energizing the System..... | 53 |
| 5.0 Installation of Optional Accessories | 54 |

| | | |
|-------------|--|-----------|
| 5.1 | Calendar Upload / Override Switch Kit Installation | 54 |
| 5.2 | RTC Time Switch Installation..... | 55 |
| 5.3 | Information Display Company Time Switch Installation | 56 |
| 5.4 | Applied Information or FCU Modem Kit Installation | 57 |
| 5.5 | 3PD Time Switch Supplementary Information..... | 59 |
| 5.6 | AC Relay Kit Installation | 61 |
| 5.7 | DC Relay Kit Installation | 62 |
| 5.8 | Polara XAV Controller Kit Installation | 63 |
| 5.9 | Polara iNX Audible Push Button Kit Installation | 64 |
| 5.10 | Campbell Guardian Audible Push Button Kit Installation | 65 |
| 5.11 | MS Sedco Passive Detector Installation..... | 66 |
| 5.12 | Dual EMS..... | 67 |
| 6.0 | Energy Management System Programming and Testing..... | 68 |
| 6.1 | EMS On-Board User Interface Operation..... | 68 |
| 6.2 | SC315-G Programming | 83 |
| 6.3 | R820-G Programming..... | 83 |
| 6.4 | R829-G Programming..... | 84 |
| 6.5 | R247-G Programming..... | 84 |
| 7.0 | Commissioning Checklist..... | 85 |
| 8.0 | Maintenance and Product Care | 86 |
| 8.1 | Fuse Replacement..... | 86 |
| 8.2 | Battery Replacement | 87 |
| 8.3 | EMS Replacement..... | 88 |
| 8.4 | EMS Recycling | 89 |
| 9.0 | Troubleshooting | 90 |
| 9.1 | BIST Error Codes | 92 |
| 10.0 | Customer Service and Warranty | 93 |
| 10.1 | Additional Products..... | 93 |
| 10.2 | Glossary..... | 94 |

1.0 Warnings and Precautions

The following symbols indicate important safety warnings and precautions throughout this manual:



WARNING indicates that serious bodily harm or death may result from failure to adhere to the precautions.



CAUTION indicates that damage to equipment may result if the instructions are not followed.



NOTE suggests optimal conditions and provides additional information.

1.1 Warranty Disclaimer

This manual will familiarize you with the features, operation standards and installation of Carmanah's G Series flashing beacons. Failure to comply with the use, storage, maintenance, installation or placement instructions detailed in this manual could void the warranty.

1.2 Standards

Perform all installation, wiring, grounding and maintenance in conformance with local building and electrical codes. Adherence to the National Electrical Code (NEC) is mandatory to comply with any certification markings. Non-adherence to code may void the warranty.

1.3 Safety and Usage Precautions



Batteries are shipped fully charged. Use extreme caution when handling the batteries as they can generate hazardous short-circuit currents. Remove all jewelry (bracelets, metal-strap watches, etc.) before handling the batteries.



Solar panels produce DC electricity when exposed to light and can therefore produce an electrical shock or burn. To render solar panels inoperative, remove them from sunlight or fully cover their front surface with an opaque material.



Before lifting any heavy or bulky equipment, ensure the load is secured so moving parts do not shift, and that it can be lifted as far as needed without back strain or loss of grip. Installation may require more than one person.



Ensure the equipment is not powered during installation and wiring of the system.



Recheck all completed wiring for proper polarity prior to energizing the system.



Changes or modifications to Carmanah equipment not expressly approved by Carmanah could void both the user's authority to operate the equipment and the warranty.



All Carmanah traffic products use a constant-current LED output circuit. Not all traffic beacons are compatible with this output. Please contact Carmanah for additional information and guidance when adding or replacing beacons or other hardware.



Product can have sharp edges. Accidental movement of hinged components can cause injury.

1.4 System Components

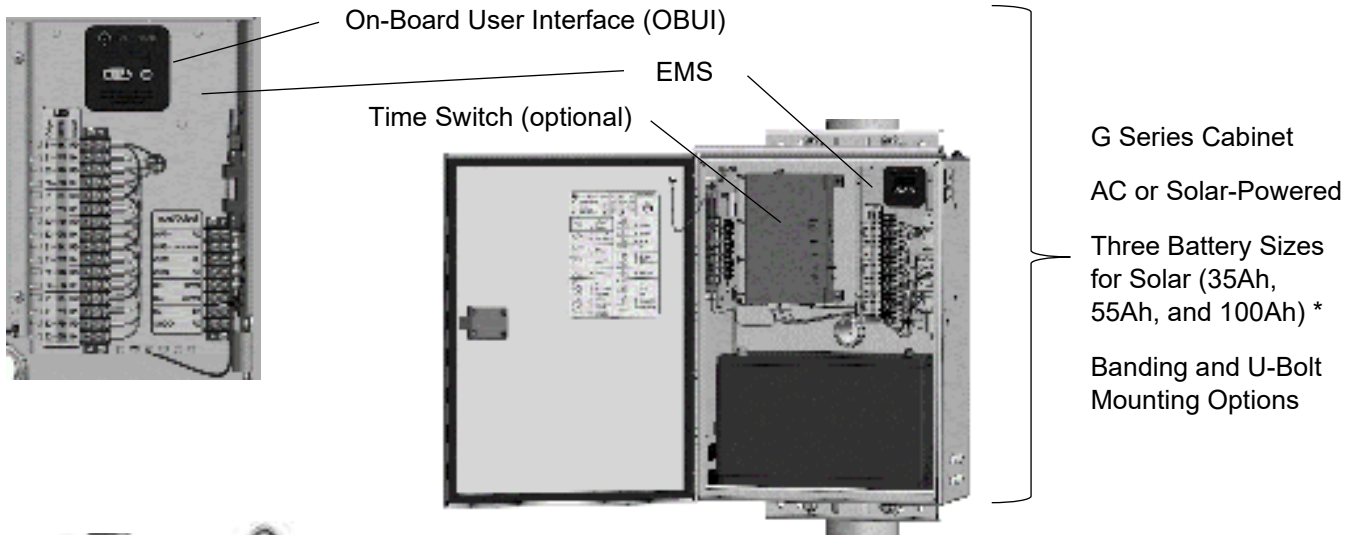
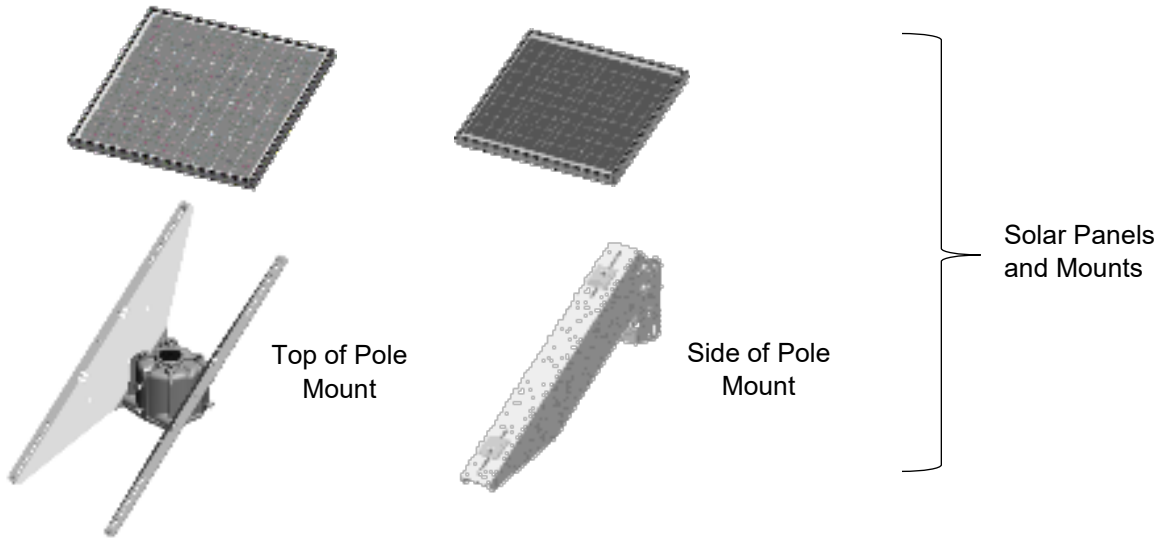

* Specific solar panel wattage and battery ratings may be subject to change.

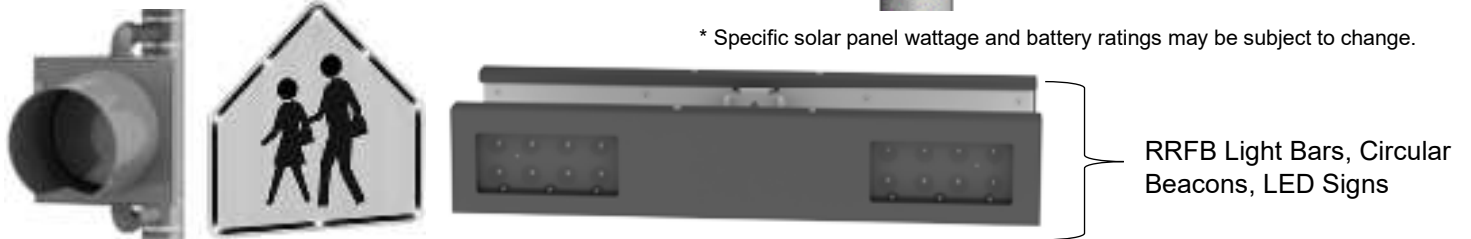

2.0 Introduction

2.1 About the G Series

The Carmanah G Series products consist of the following models:

| Models | Applications | LED type(s) | Radio Communication |
|---------|------------------------------|--|---------------------|
| SC315-G | Pedestrian crosswalks | RRFB or LED-enhanced signs | Standard |
| R820-G | Pedestrian crosswalks | Circular beacons or LED enhanced signs | Standard |
| R829-G | School zones, calendar-based | Circular beacons or LED enhanced signs | Optional |
| R247-G | Continuous 24/7 operation | Circular beacons or LED enhanced signs | N/A |

The G Series models are available in solar and AC versions, and all share a common cabinet. Solar models are available with panel wattages of 20, 50, or 80W, and 12V batteries of 35, 55, or 100Ah capacity. The G Series can also accommodate third-party devices. While all G Series products share the same user interface on the Energy Management System (EMS) controller, different models and configurations may differ in behavior, types of fixture, fixture harnesses, wireless operation, and other aspects. Contact Carmanah if you would like to repurpose a system from its original model and configuration. Each system will be described in full later in this user manual.

G-Series Cabinet Dimensions

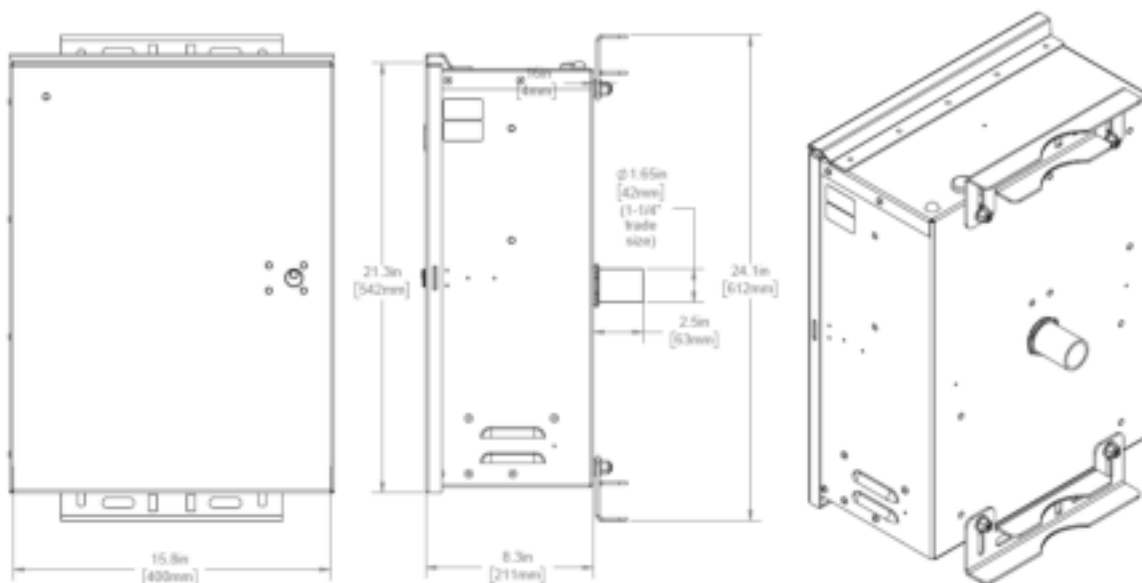

Ensure cabinet door is fully closed and latched otherwise damage may occur.



The cabinet can be ordered with an alternate padlockable latch for extra security.



Specific solar panel and battery capacities may vary.

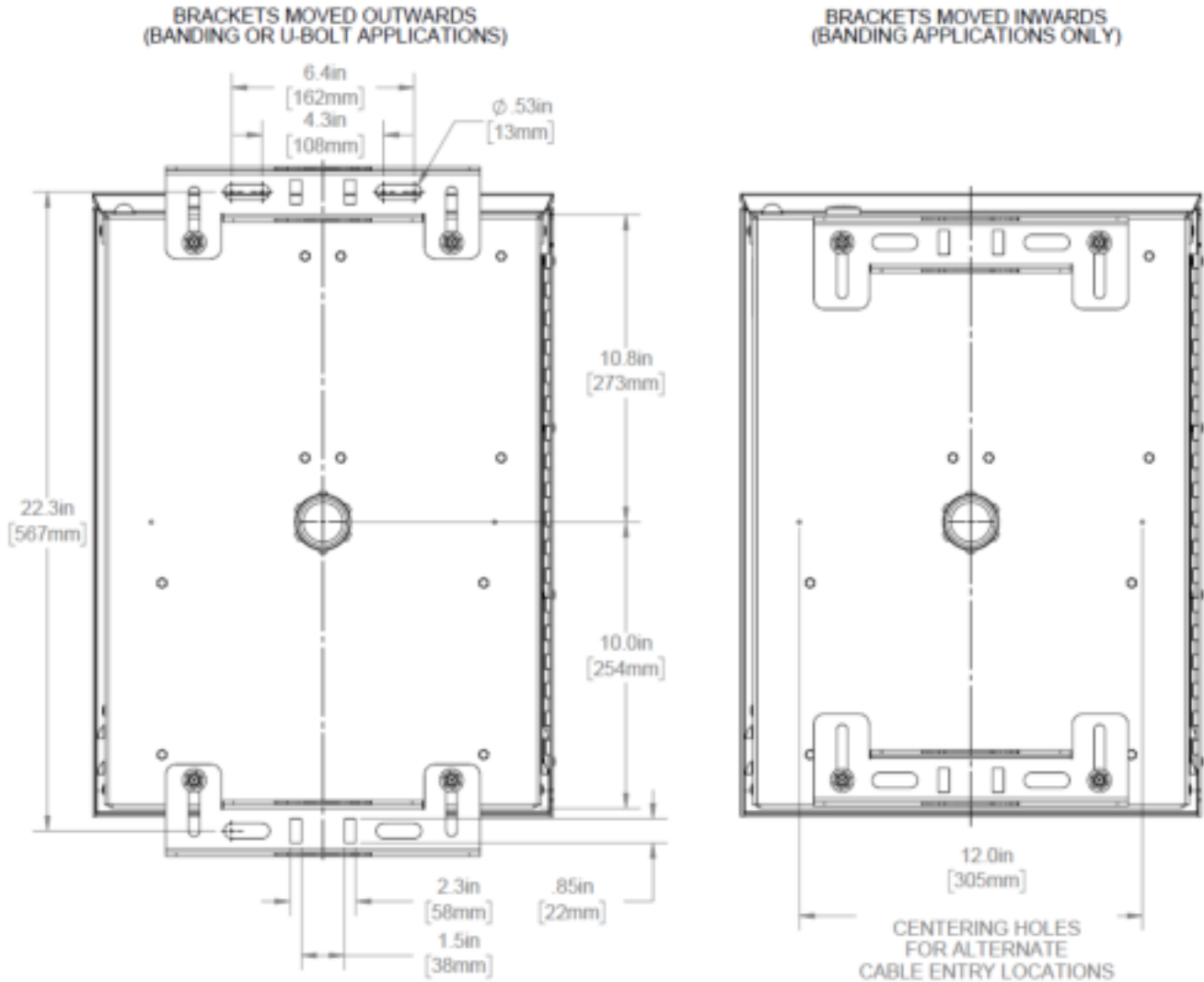

If required, alternate or additional cable entry holes can be drilled at the locations shown above. Use in conjunction with the Hole Plug Kit if removing original cable entry point.



Ensure all wiring is secured away from area before drilling to avoid damage. Carefully remove all shavings from within the cabinet before proceeding with installation.

2.2 Ambient Brightness Sensor

Each Energy Management System (EMS) in a G Series is equipped with an ambient brightness sensor on its circuit board. Through a combination of a light pipe attached to the circuit board and a window on the top of the cabinet, the G Series can detect ambient light levels outside the cabinet. The G Series uses that data to determine whether it is day or night, and the amount of AAA (Ambient Auto Adjust) to apply (if enabled). Keep the ambient brightness sensor clean and clear of debris to ensure accurate light measurements.

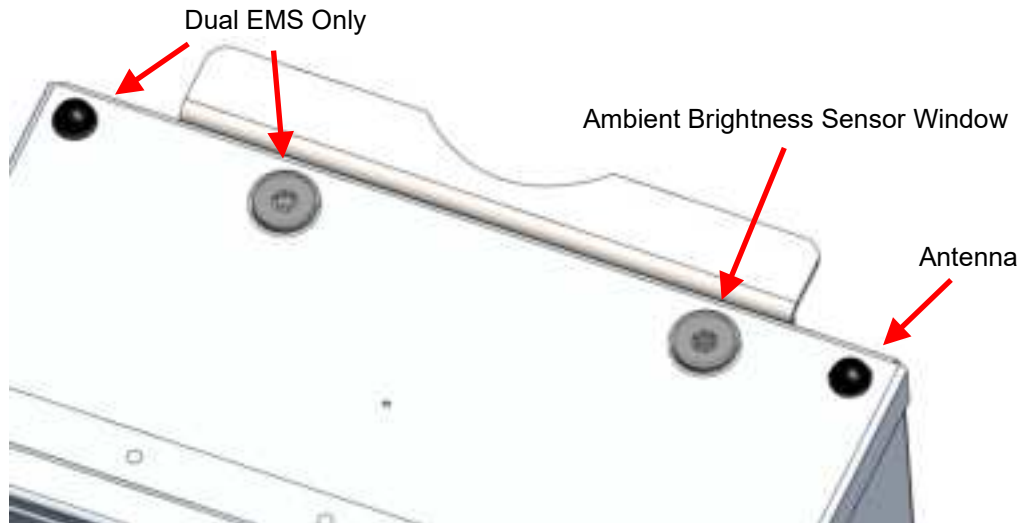

Dual EMS G Series systems have a second antenna and ambient brightness sensor window

2.3 Radio Communication

Radio communication between products is standard in R820-G and SC315-G systems and is an option in R829-G systems. In addition to the G Series, Carmanah also manufactures smaller, self-contained E and F Series products in which the solar panel, batteries, EMS, and third-party devices reside together in a “solar engine” enclosure. Wireless communication works seamlessly between products regardless of whether they are E, F, or G Series. R820 and SC315 systems will also activate each other when a pedestrian pushes the push button.

The radio modules use 2.4GHz DSSS (Direct Sequence Spread Spectrum) with an AES128 encrypted signal and have been tested with clear line of sight (with no nearby interference or reflected signals) to 1,000 feet (305 meters). Performance is reduced if clean line of sight is not possible.

The G Series products use a low-profile antenna that does not require any special orientation or adjustment and is resistant to vandalism.

NOTE

To increase the reliability of radio communications, the different units should be located and oriented so that there is direct line-of-sight between the antennas and so that structures or sources of interference (large signs, overpasses, powerlines, etc.) are as far away from the communication path as practical.

2.4 Label Explanation

The G Series identification labels appear in two formats—one for solar-powered and one for AC-powered. The information appearing on the labels is described below:

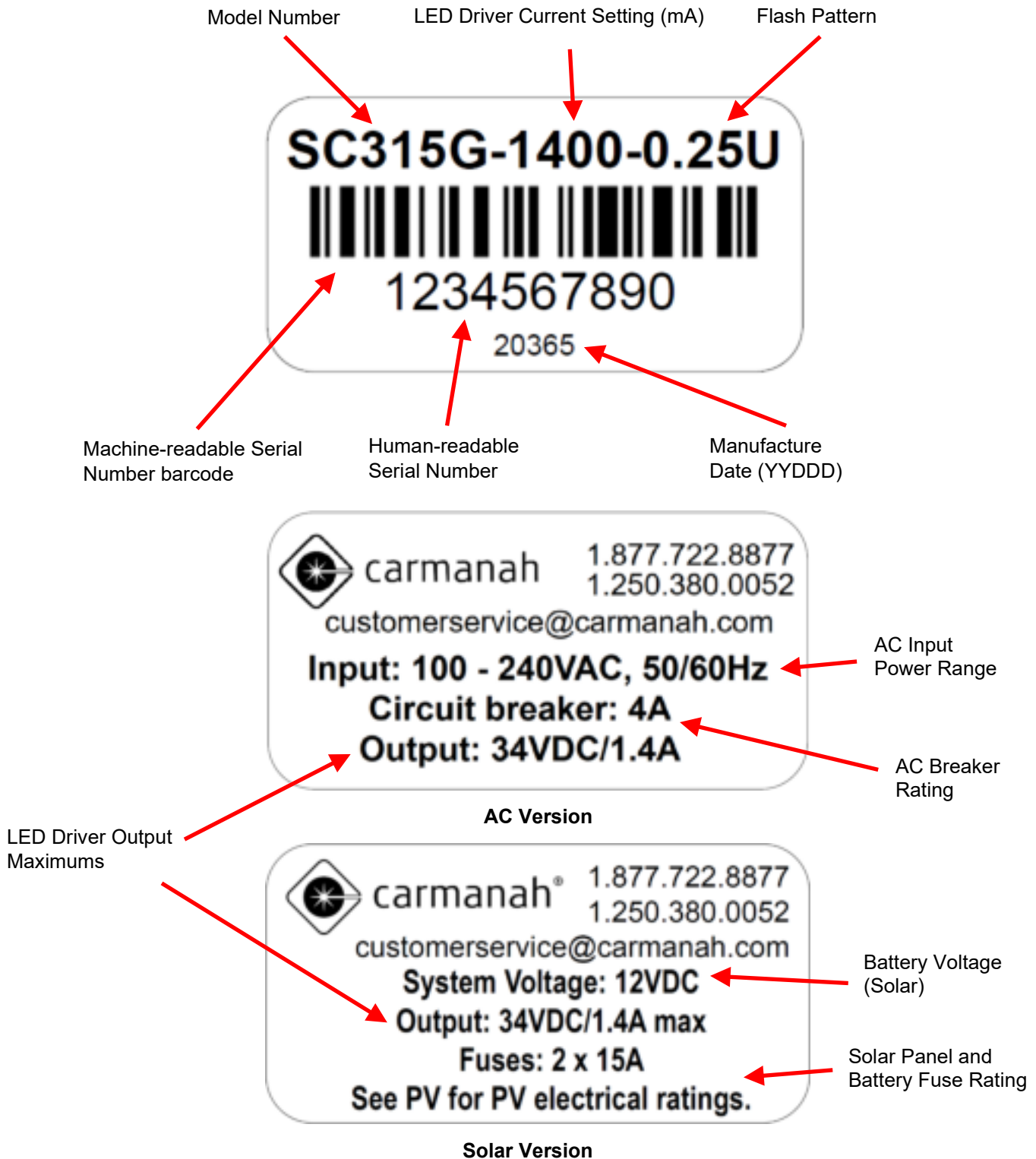

2.5 SC315-G: Pedestrian Crosswalk with RRFB Light Bars

Overview

The SC315-G LED Rectangular Rapid Flashing Beacon (RRFB) products are ideal for uncontrolled pedestrian-activated crosswalk applications. Multiple SC315-G units can be combined to create a complete crosswalk set. Each SC315-G is radio-controlled, and each synchronizes flashing with other SC315-Gs and R920-E/Fs or advance R820-E/F/Gs. The system will flash for a pre-set duration (field-adjustable) upon activation of the push button. Spread-spectrum wireless communications activates the light bars across the street or in advance of the crossing. A typical installation consists of two pairs of light bars, with each pair mounted on poles at opposite ends of the crosswalk. Wireless communication between units means that SC315-Gs require no trenching of cables across the roadway.

Details on RRFB light bars can be found in [Section 2.9](#) and [Section 4.1](#).

As an alternative to light bars, SC315-G systems can be configured with LED-enhanced signs. Details on LED-enhanced signs can be found in [Section 2.11](#) and [Section 4.3](#).

Typical SC315-G Configurations



Typical SC315-G Configurations, cont'd

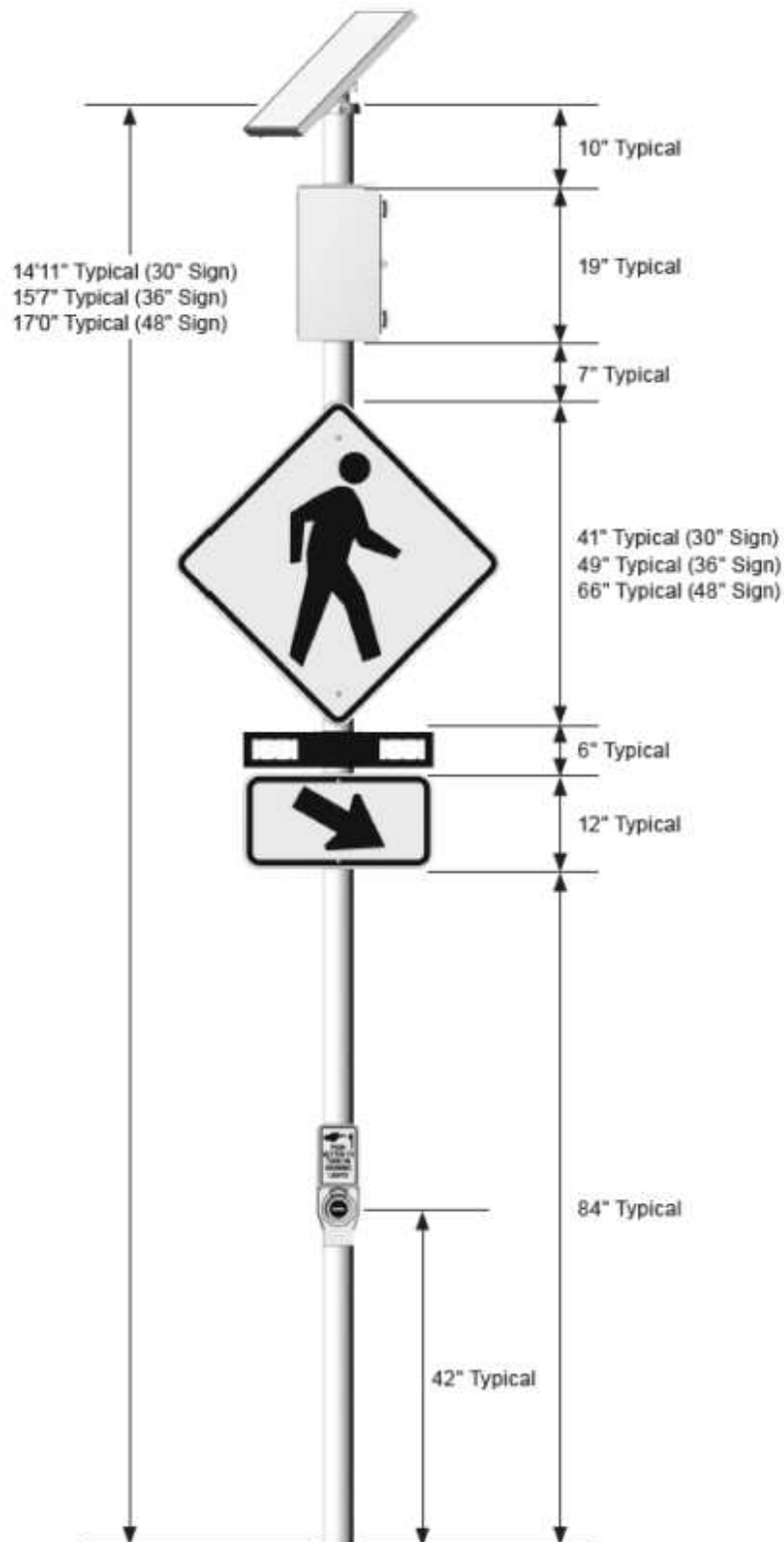

2.6 R820-G: Pedestrian Crosswalk with Circular Beacons

Overview

Multiple R820-G units can be combined to create a complete crosswalk set. Each R820-G is radio-controlled, and each synchronizes flashing with other R820-Gs in the crosswalk set. The system will flash for a pre-set field-adjustable duration upon activation of the push button. Wireless communication activates the beacons across the street or in advance of the crossing. A typical installation consists of two pairs of flashing circular beacons, with each pair mounted on poles at opposite ends of the crosswalk. Wireless communication between units means that R820-Gs require no trenching of cables across the roadway.

R820-Gs can also be wirelessly controlled by an R829-G master controller. The R820-Gs and R829-G operate together based on the schedule programmed into the R829-G's internal calendar.

Details on circular beacons can be found in [Section 2.10](#) and [Section 4.2](#).

As an alternative to circular beacons, R820-G systems can be configured with LED-enhanced signs. Details on LED-enhanced signs can be found in [Section 2.11](#) and [Section 4.3](#).

Typical R820-G Configuration



2.7 R829-G: School Zone Flashing Beacon

Overview

The R829-G School Zone Flashing Beacon systems operate on a programmable calendar used to set the days and times when the beacon(s) will flash. There are four ways that an R829-G system can follow a calendar schedule:

- 1) A non-wireless R829-G can operate on its own, automatically flashing based on the schedule programmed into its internal calendar.
- 2) A non-wireless R829-G can also be turned on and off through a hard-wired switch. This switching function can be provided by an override box, a third-party time switch, or both.
- 3) A wireless R829-G can operate as the master controller in a group of wireless Carmanah E, F, or G Series traffic products.
- 4) Other Carmanah E, F, or G Series products respond to commands from a wireless R829-E/F/G master controller system and operate according to the master's calendar schedule.

Details on circular beacons can be found in [Section 2.10](#) and [Section 4.2](#).

As an alternative to circular beacons, R829-G systems can be configured with LED enhanced signs. Details on LED enhanced signs can be found in [Section 2.11](#) and [Section 4.3](#).

NOTE

G Series products feature optional time switch kits that allow various third-party products to be mounted within the solar engine. See [Section 2.12](#) and [Section 5.0](#) for details.

Typical R829-G Configuration



Internal Calendar (standard on R829-G, optional on other systems)

The R829-G is equipped with an internal calendar that is programmed via USB to automatically activate and deactivate school zone flashers on a user-defined schedule of up to 512 days. The calendar is programmed using an intuitive Microsoft Windows-based graphical user interface. Once the program is established for one system, the settings can be uploaded to other R829-G units onsite with a laptop PC. A USB cable is part of the School Zone Programming Kit and is provided coiled up inside the R829-G cabinet.

Eight different day schedule types can be defined (including OFF all day). Each day type can be configured for up to eight ON periods of adjustable duration. Refer to the support document “R829 School Zone Calendar Configuration Instructions” for additional information and complete programming instructions.

NOTE

Ensure you obtain the latest copy of the calendar software (Version 1.2.0 as of May 2020). Older versions of the calendar software will not operate correctly with the newest version of traffic firmware. Minimum Windows 7 operating system is required (32-bit or 64-bit). The software can be obtained by contacting Carmanah Sales or visiting: support.carmanah.com. The software is also included on a USB memory stick in the School Zone Programming Kit, which also includes a 32-foot active USB extension harness which can be used to program a system's calendar from a vehicle.

NOTE

See [Section 5.1](#) for more information about related accessory Calendar Upload / Override Switch Kit.

2.8 R247-G: 24-Hour Flashing Beacon

Overview

The R247-G Flashing Beacon flashes continuously 24 hours per day 7 days per week and is used for a wide range of warning applications such as stop lights and low bridges.

The R247-G can be turned off when required using the optional Override Switch Kit, see [Section 5.1](#).

Details on circular beacons can be found in [Section 2.10](#) and [Section 4.2](#).

As an alternative to circular beacons, R247-G systems can be configured with LED-enhanced signs. Details on LED-enhanced signs can be found in [Section 2.11](#) and [Section 4.3](#).

Typical R247-G Configuration

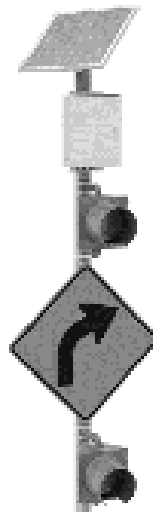

2.9 RRFB Light Bars: Overview

Standard G Series products support up to four RRFB light bar fixtures, or up to eight for dual EMS systems. The FHWA Interim Approval 21 March 20th, 2018 defines the flash pattern of the RRFB and specifies the J595 standard for photometrics. Each light bar consists of a left and right module, with each module having eight LEDs connected in series. In addition, each end of a light bar has a single “confirmation” LED that pedestrians can see from across the street and know with confidence that the light bars are flashing in response to their pressing of the pedestrian push button. Opaque adhesive covers are included to optionally cover the confirmation LED if desired.

See [Section 4.1](#) for information on installing and aiming light bars.

NOTE

When programming intensity for **RRFBs**, minimum current settings must be applied to maintain SAE J595 compliance, (see [Flash Pattern](#) and [Intensity](#) in [Section 6.1](#)). Contact Carmanah for guidance.

Dual Confirmation Light
– No Opaque Cover

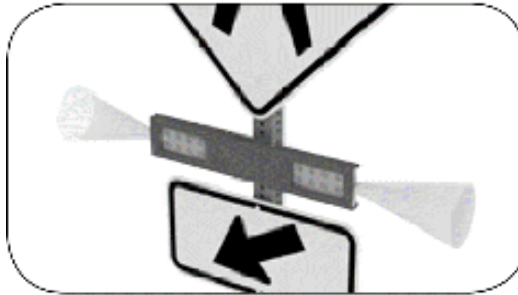

Single Confirmation Light
– Using Opaque Cover

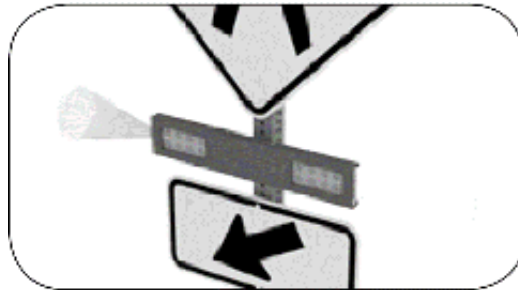

2.10 Circular Beacons: Overview

Standard G Series products support up to eight circular beacons, or up to 16 for dual EMS systems. The beacons are industry-standard equipment and comply with MUTCD and ITE flash patterns, color, beam shape, and intensity. Beacon wiring is provided with a convenient terminal strip inside the signal head(s) for easy wire connection.

NOTE

LED loads driven from one EMS must have the same operating voltage. Do not mix different sizes, colors, or types of LED loads connected to the same EMS. Use a dual-EMS G Series system to drive two different LED load types.

NOTE

When an odd number of circular beacons is used, a unison or the special 0.5A3 (see [Section 2.12](#)) flash pattern must be selected to achieve consistent brightness between beacons.

NOTE

All Carmanah traffic products use a constant-current LED output circuit. Not all traffic beacons are compatible with this output. Please contact Carmanah for additional information and guidance when adding or replacing beacons or other hardware.

NOTE

When programming intensity for **ITE-compliant circular beacons**, minimum current settings must be applied (see [Flash Pattern](#) and [Intensity](#) in [Section 6.1](#)). Contact Carmanah for guidance.

NOTE

Increasing the Intensity setting can affect the solar energy balance of the system. Contact Carmanah to for more information about sustainable settings in your location.

See [Section 4.2](#) for information on installing circular beacons.

2.11 LED Enhanced Signs: Overview

In addition to RRFB light bars and circular beacons, G Series products can power LED enhanced signs. LED enhanced signs are available in a variety of formats including stop and pedestrian crosswalk signage. LED enhanced signs are electrically connected and driven directly by the EMS like other traffic fixtures. LED enhanced signs have the same degree of intensity and flash pattern control as other fixtures.

**NOTE**

LED loads driven from one EMS must have the same operating voltage. Do not mix different sizes, colors, or types of LED loads connected to the same EMS. Use a dual-EMS G Series system to drive two different LED loads.

NOTE

When an odd number of LED loads is used, a unison or the special 0.5A3 flash (see [2.12](#)) pattern must be selected to achieve consistent brightness between loads.

NOTE

All Carmanah traffic products use a constant-current LED output circuit. Not all traffic beacons are compatible with this output. Please contact Carmanah for additional information and guidance when adding or replacing beacons or other hardware.

See [Section 4.3](#) for information on installing LED enhanced signs.

2.12 Alternating Three Beacon Setup

Flash code 0.5A3 allows a single EMS to operate 3 beacons in an alternating 0.5 sec on, 0.5 sec off configuration while maintaining the same intensity across all 3 beacons.

When selected, the second LED bank will provide only half of the current of first LED bank so that beacons 1 and 3, connected to the harnesses labeled “LED B1”, and beacon 2, connected to harness labeled “LED B2”, will have the same brightness.

See [Section 3.5](#) for details on LED banks and beacon connections.

Beacons 1 and 3 flash in unison but face in the opposite direction, so a driver will either see Beacon 3 only or see Beacons 1 and 2 alternate at the same intensity.

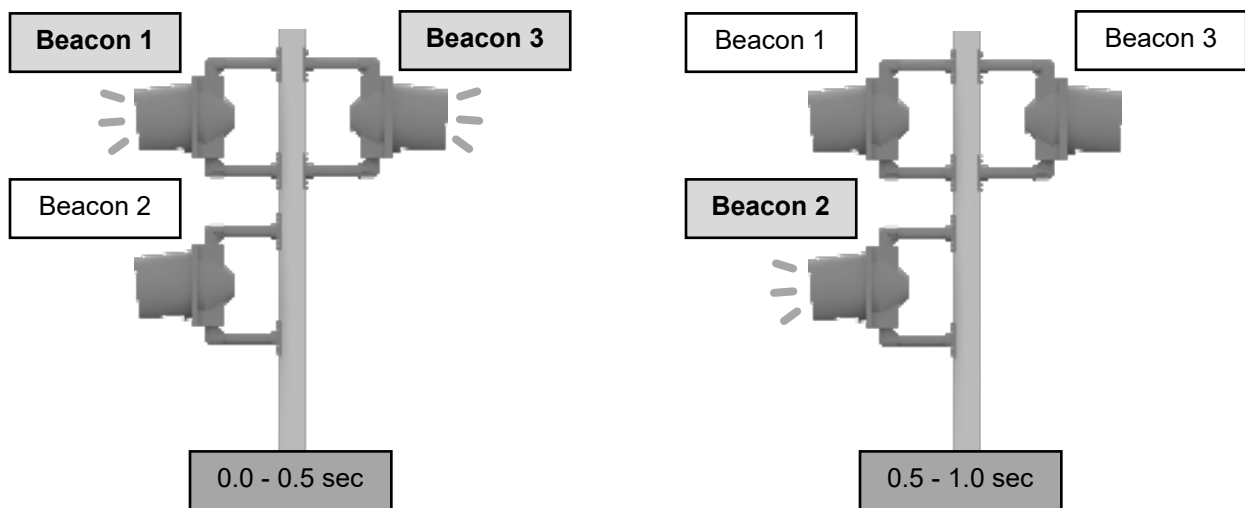
NOTE

Flash code 0.5A3 is only available with EMS firmware 1.1.3.0 or later. See Firmware Version in [Section 6.1](#) for instructions on how to check the EMS firmware version.

NOTE

The beacons must be connected and installed as detailed here to obtain the desired result, see (see [Flash Pattern](#) and [Intensity](#) in [Section 6.1](#)).

NOTE

LED loads driven from one EMS must have the same operating voltage. Do not mix different sizes, colors, or types of LED loads connected to the same EMS. Use a dual-EMS G Series or additional E/F systems to drive different types of LED loads.

2.13 Multiple Steady-On Loads

The “stdy” flash code allows the use of steady-on loads. Only one LED bank is active when using this flash pattern and multiple loads must only be connected in series. The combined forward voltage of the loads must be less than 30V but different load types may be mixed in this configuration and will all receive the same current.

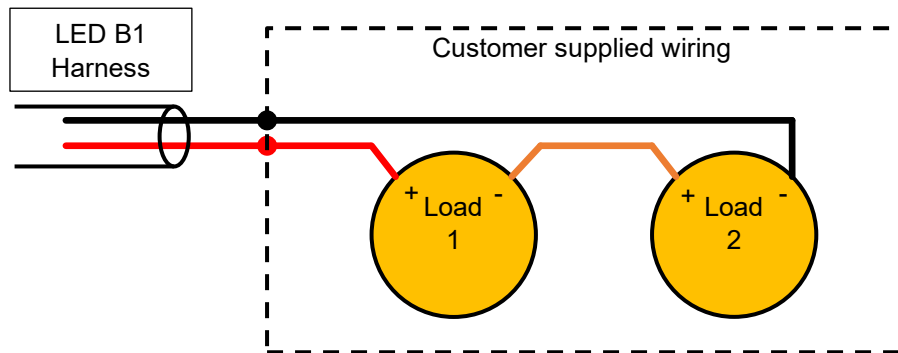

Flash code stdY is only available with EMS firmware 1.1.3.0 or later. See Firmware Version in [Section 6.1](#) for instructions on how to check the EMS firmware version.



Custom harnessing (not supplied by Carmanah) is required to wire loads in series.

2.14 Third-Party Devices: Overview

A third-party device (3PD) is non-Carmanah equipment that interacts with the system in one or more ways:

- The G Series provides a status signal to 3PD (e.g. Digital Output signals when fixtures are flashing, allowing 3PD equipment such as overhead lighting to activate)
- The 3PD provides control signal to G Series (e.g. time switch, passive pedestrian detection, water level detectors)
- The G Series only provides power to 3PD (e.g. radio/communications)



Installation of a 3PD in a solar-powered system where the device load exceeds the available system power may result in over-discharge and subsequent damage to the batteries. Contact Carmanah for guidance on the use of 3PDs.

The G Series is available with several optional 3PD kits which allow the installation of the 3PD within the G Series cabinet:

- The G Series RTC/IDC Time Switch Kit option allows the installation of an RTC or IDC time switch and includes a mounting plate, switch mounting hardware, and a prewired harness with a connector that plugs into the time switch (time switch not included). For installation information see [Section 5.2](#), [Section 5.3](#) and [Section 5.5](#).
- The G Series Applied Information Modem Kit option allows the installation of an AI time switch and cellular modem. It includes mounting hardware, an antenna, and a prewired, connectorized harness to interface between the G Series and the AI time switch and modem. (AI time switch/modem not included). For installation information see [Section 5.4](#) and [Section 5.5](#).
- The G Series Relay Kit For Digital Output, AC option comes with a 10A AC relay prewired to the G Series EMS. For installation information see [Section 5.6](#).
- The G Series Relay Kit For Digital Output, DC option comes with a 10A DC relay prewired to the G Series EMS. For installation information see [Section 5.7](#).
- The G Series Polara XAV Controller Kit option includes the Polara XAV controller prewired for the Polara XAV2E audible push button assembly. Push button station harness length options are 16ft, 36ft, or 75ft. For installation information, see [Section 5.8](#).
- The G Series Polara iNX Push Button Kit includes a push button harness (16ft, 36ft, or 75ft) prewired to the G Series EMS, along with the iNX audible push button assembly and R10-25 pedestrian push button sign. This new model is intended to replace the Polara XAV push button. For installation information, see [Section 5.9](#).
- The G Series Campbell Guardian Audible Push Button Kit includes a push button harness (16ft, 36ft, or 75ft) prewired to the G Series EMS, along with the Guardian audible push button assembly and R10-25 pedestrian push button sign. For installation information, see [Section 5.10](#).

NOTE

Contact Carmanah for additional support in connecting and configuring the above devices or other third-party devices.

3.0 Solar Panel and Cabinet Installation



Ensure the installation location has an unobstructed view of the sun's path. Obstructions such as trees or buildings could significantly reduce the amount of sunlight on the solar panel. Shade analysis is highly recommended to understand how shadows will change according to the time of year. Contact Carmanah for a detailed examination and solar simulations for your site.



To increase the reliability of radio communications, the different units should be located and oriented so that there is direct line-of-sight between the antennas and so that structures or sources of interference (large signs, overpasses, powerlines, etc.) are as far away from the communication path as practical.

3.1 Tools and Materials Required

The following tools and materials may be required to mount your Carmanah flashing beacon depending on the model and configuration:

| | |
|---|--|
| <ol style="list-style-type: none"> 1. Imperial socket set 2. Crescent wrench 3. Tap set 4. Imperial Allen-Wrench set 5. Fish tape 6. Level 7. Compass or pre-determined equatorial direction | <ol style="list-style-type: none"> 8. Drill and drill bits 9. Fine tip felt marker 10. Multi-bit screwdriver 11. Pelco Roger-Wrench (some configurations) 12. Hook spanner wrench, 1-1/2" trade size (some configurations) 13. Ladder or lift device 14. Lithium grease |
|---|--|

3.2 Pole Preparation

1. Mark positions of flashing beacons, cabinet, and side of pole mount (if required) on pole.
2. Drill 1-3/4" dia. hole at desired position of cabinet nipple.
3. Drill cable exit/entry points for the flashing beacons and side of pole solar panel mount (if used).
4. Fish solar harness between top of pole (or side of pole mount hole) to cabinet nipple hole.
5. Fish flashing beacon harnesses between cabinet nipple hole and flashing beacon holes.

3.3 Solar Panel Installation

There are two options for mounting the G Series solar panel:

- Top of Pole – Fixed at 45° angle with built-in bird deterrent.
- Side of Pole – Adjustable inclination angle. Set it for 45° unless Carmanah has conducted solar simulations that resulted in a recommendation for a different panel inclination angle.

Top of Pole Solar Panel Installation (legacy - Galvanized Steel Mount)

1. Attach tenon clamp brackets to 45° mount. Use 1/4" bolts and 1/4" locknuts supplied. Tighten nuts and bolts securely.

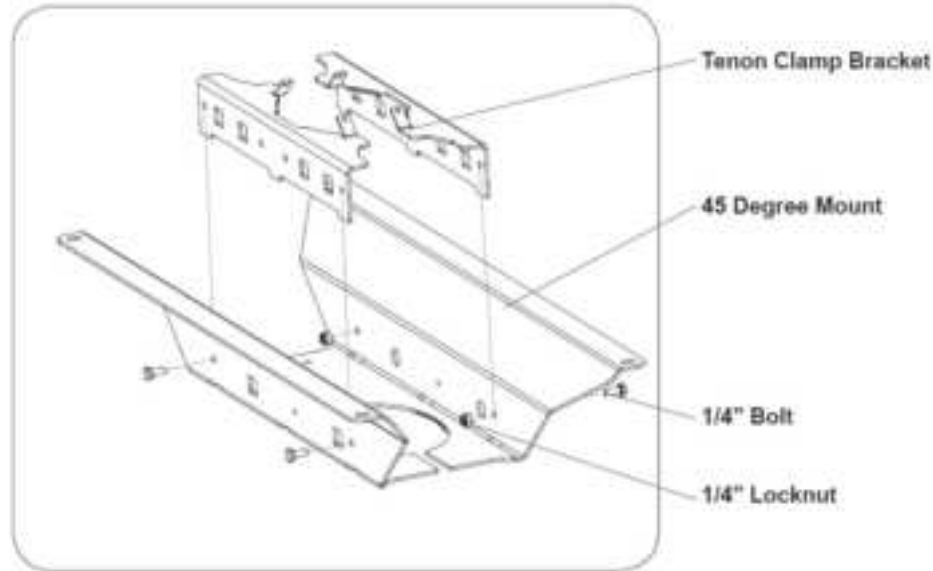

2. If needed, install bird deterrent spikes with 1/4" bolts and lock nuts as shown.

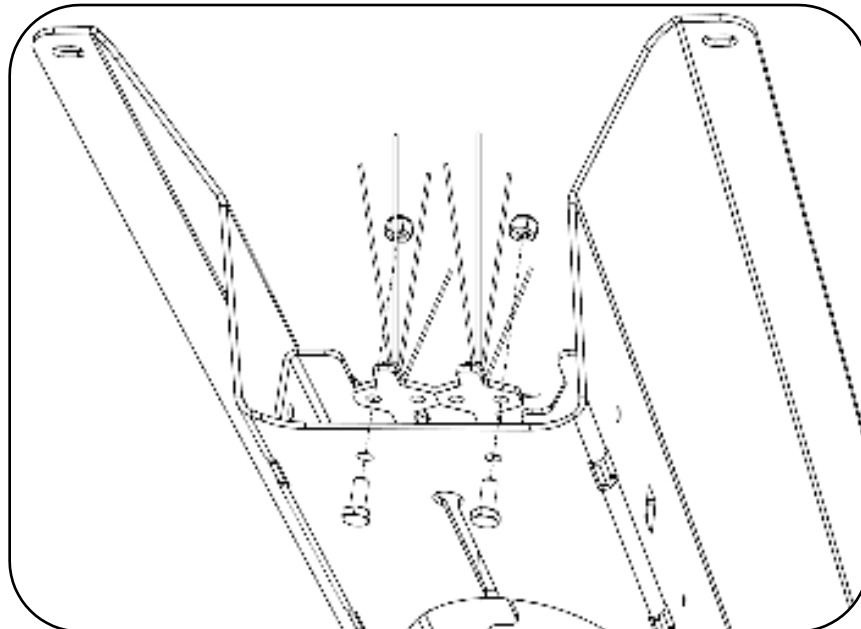

3. Attach the solar panel to the 45° mount. Use bolts, washers, and locknuts that were supplied. Tighten nuts and bolts loosely—**do not fully tighten** at this stage.

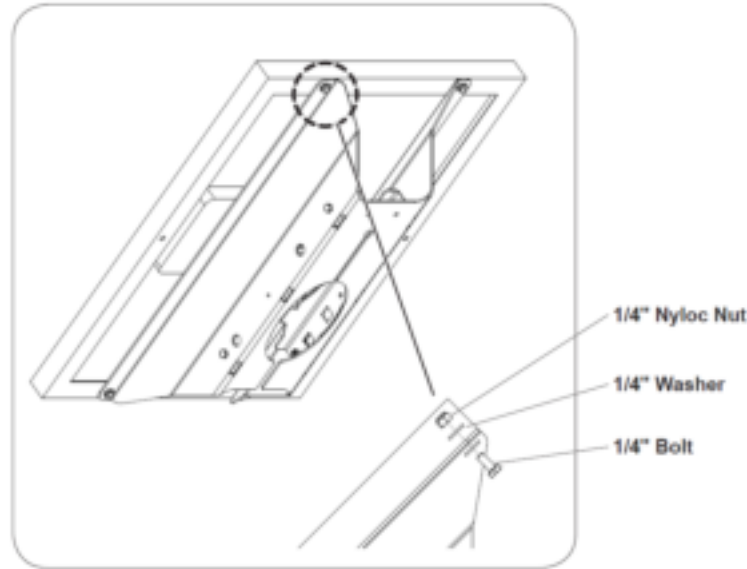

4. Drill 1-3/4" dia. hole in the pole in the desired cabinet location.

Your system includes a cap for the open top of the pole. The cap prevents debris from entering the pole. There are plastic and metal versions of the cap:

NOTE

- The plastic cap is inserted into the top of the pole prior to attaching the solar mount bracket.
- The metal cap is used by Miami-Dade County and is attached to the solar panel mounting bracket before the solar panel is mounted on the pole. Instructions are provided at the end of this section.

PLASTIC CAP INSTALLATION (FOR LOCATIONS OTHER THAN MIAMI-DADE COUNTY):

5. Fish solar panel harness through pole and plastic cap as shown, with black connectors at top.

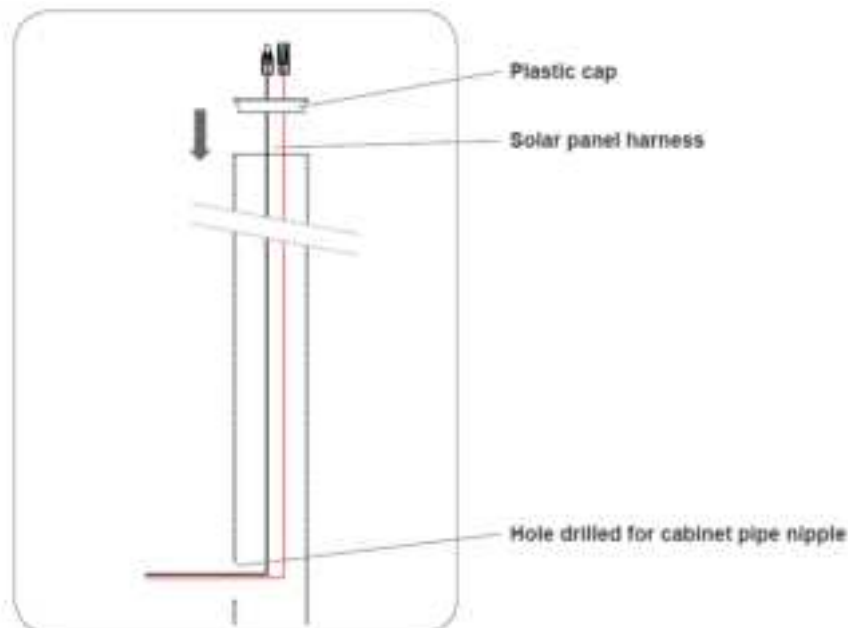

METAL CAP INSTALLATION (Alternate Option):

6. Install the metal cap, grommet, and hardware onto the bracket as shown.

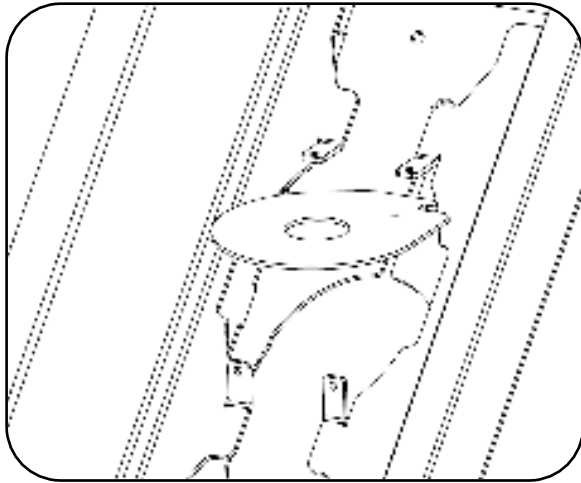

7. Lower solar panel and top of pole bracket down onto pole. For metal caps, route solar cables up through grommet in cap. Make sure panel mount sits securely on top of pole cap as shown below (solar panel not shown to allow visibility of pole top). When setting top of pole mount on pole, ensure two tabs are resting on lip of pole cap. Also, look underneath solar panel to ensure wiring is not pinched.

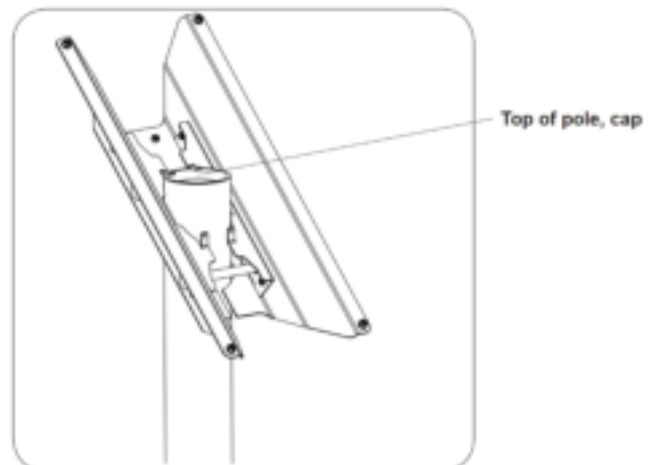

- Mate black MC4 connectors from solar panel to those from solar harness. A click noise indicates they are fully mated. Tuck excess harness length down into pole or coil up excess harness and cable tie securely, if desired.

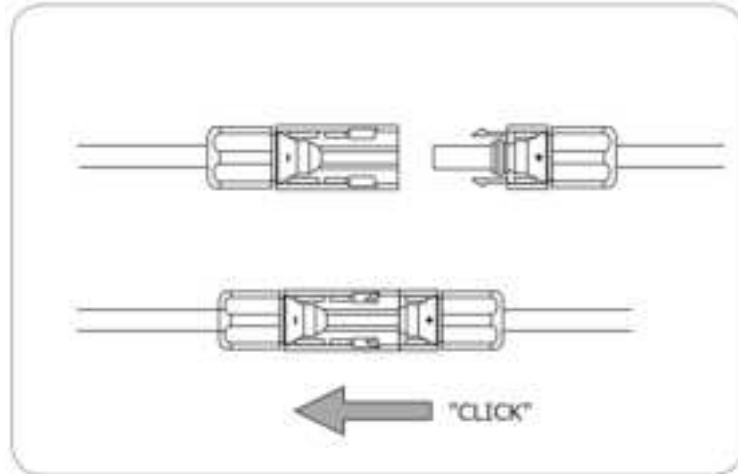

- Ensure solar panel is facing equator (pointing south if you are in the Northern Hemisphere).



10. Install and tighten 5/8" bolts, washers, and nuts to secure top of pole bracket to pole as shown.

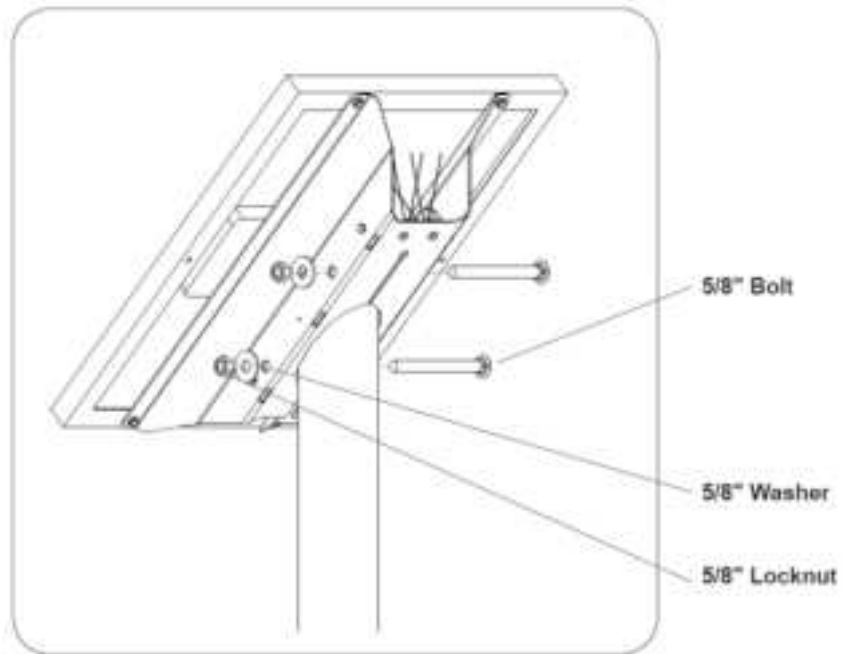

11. Tighten four nuts and bolts securing solar panel to bracket.

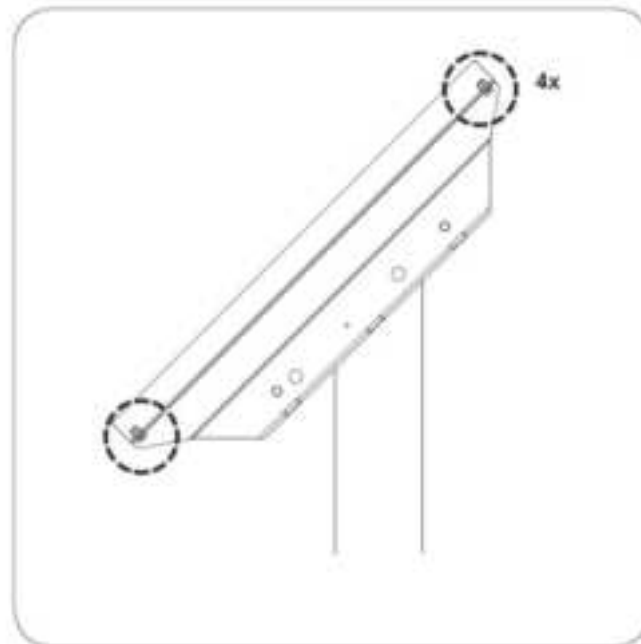

Top of Pole Solar Panel Installation (Cast Mount)

1. Install grommet and thread 6x 3/8" bolts into casting. Only thread in a few turns so bolts do not protrude inside.

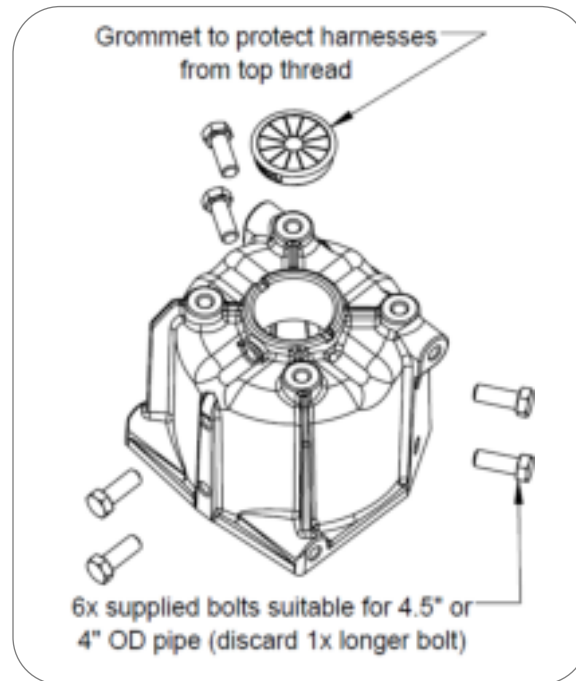

2. Attach both sheet metal brackets to solar panel using supplied 1/4" bolts, washers and locknuts. Install casting between brackets with supplied 3/8" bolts and washers. Tighten 3/8" bolts first.

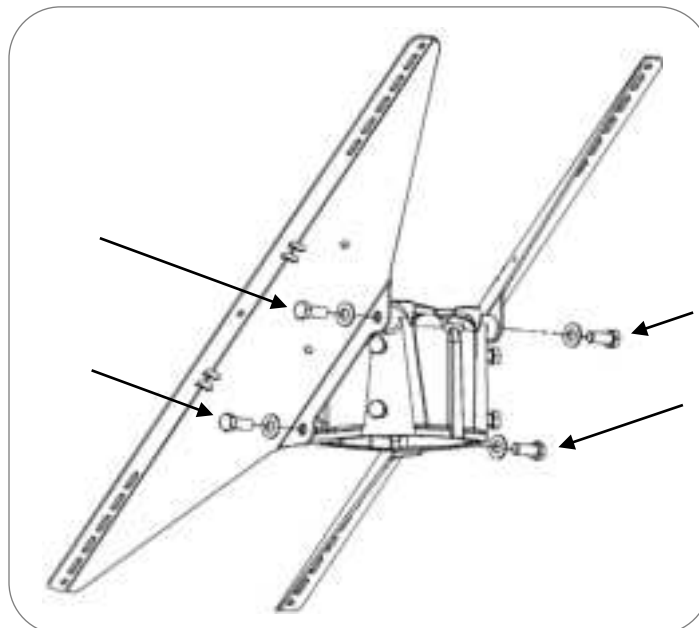

3. Attach solar panel to top of pole mount using supplied 1/4" bolts, washers and locknuts. Leave nuts finger tight. **DO NOT FULLY TIGHTEN** at this stage.

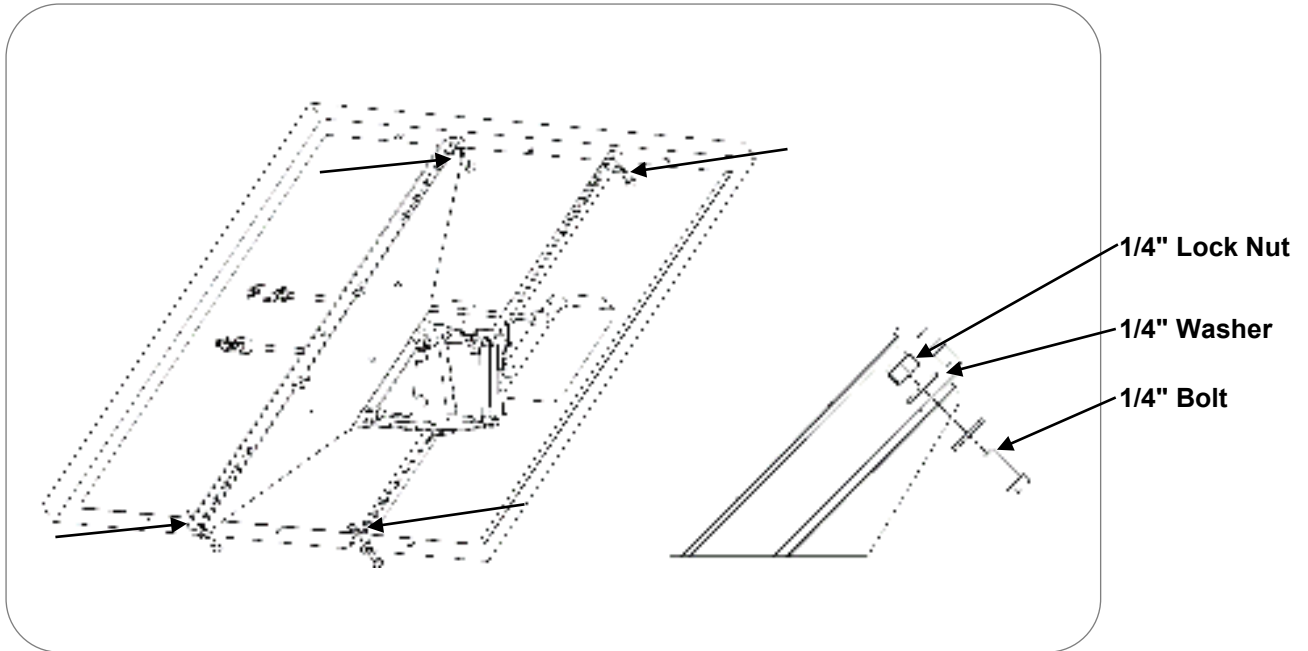

4. Slide casting over top of pole and orient so panel faces South (in Northern Hemisphere). Tighten the 6x 3/8" bolts to secure casting to pole (image shows solar panel removed for illustration purposes).

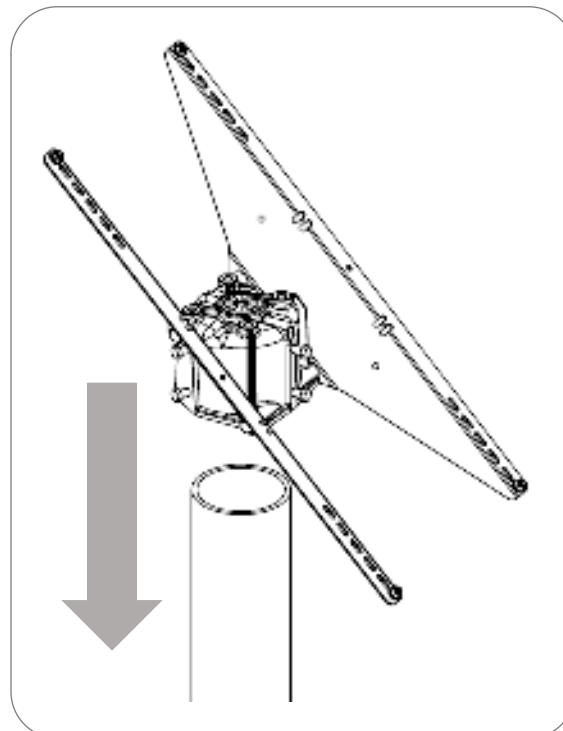

Note: Solar panel omitted for clarity

5. Tighten 1/4" bolts and nuts to secure solar panel to mount.

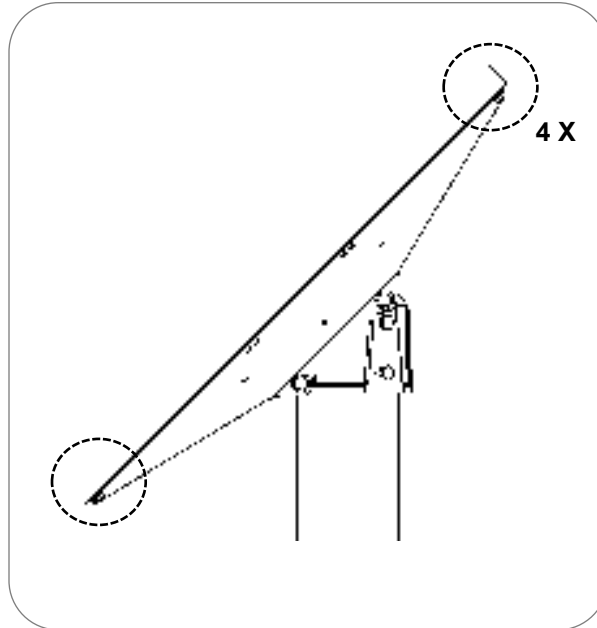

6. Route supplied solar panel wires down pole and through hole for cabinet conduit nipple (side of pole shown).

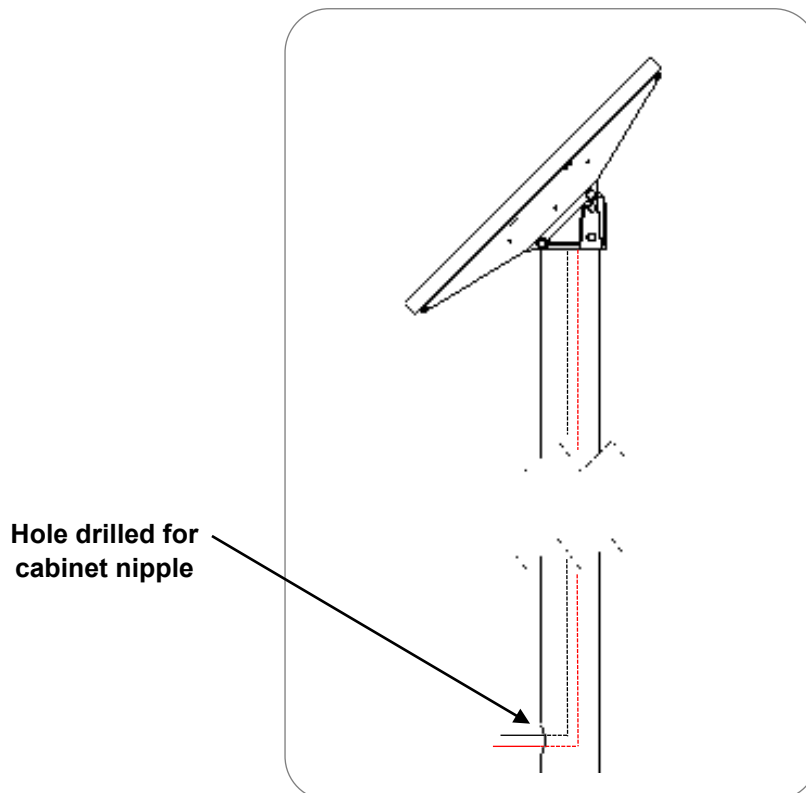

Side of Pole Solar Panel Installation

1. Assemble side of pole mount using instructions provided. Install at 45° tilt angle unless advised otherwise by Carmanah. Orient mount so panel will face the equator (pointing south if in the Northern Hemisphere).

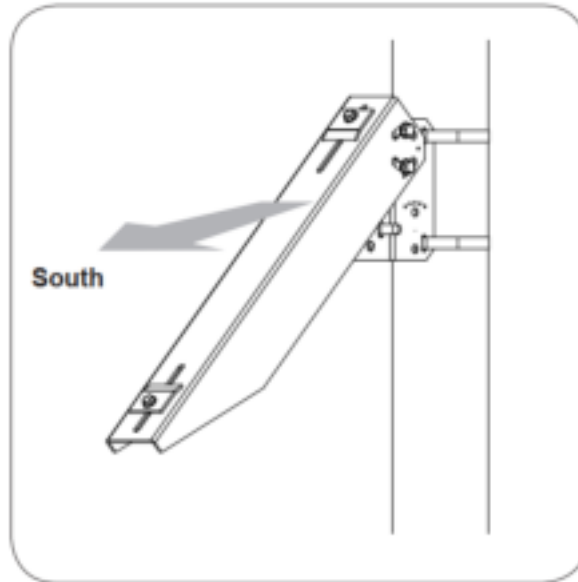

Follow assembly and torque specifications provided with side of pole mount.

2. Attach solar panel to mount using direct bolt option or clamps provided.

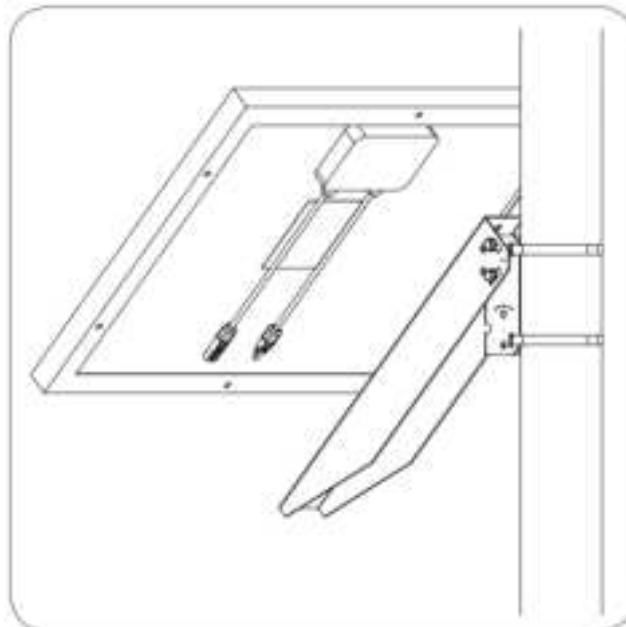

3.4 Cabinet Installation

NOTE Before mounting the cabinet to the pole, all wiring internal to the pole (power, LED, optional StreetHub™ serial and ground cables) should be fished.

1. Loosen four nuts on back of cabinet and spread brackets outward. Tighten nuts to 20 ft-lb.

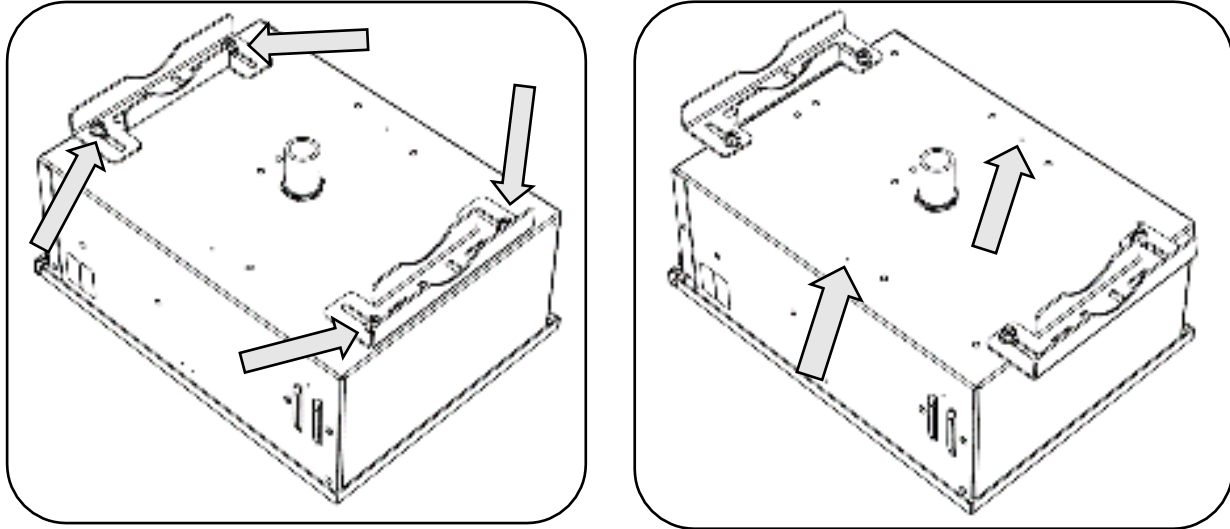

NOTE On the back of the cabinet, there are 2 drill points that may be used for routing of liquid-tight conduit external to the mounting pole. Prior to drilling the cabinet, ensure there are no components which may be damaged on the inside of the cabinet.

2. Drill a 1-3/4" diameter hole in pole for cabinet pipe nipple at desired position. An optional hole plug kit is available if the pipe nipple is removed from the cabinet (see below).



Hole Plug



Hole Plug installed

3. Route cables from pole into cabinet and temporarily affix cabinet against the pole. For U-bolt mounting, install U-bolts, washers and nuts then torque to 30 ft-lb. For banding, install banding through openings in brackets.

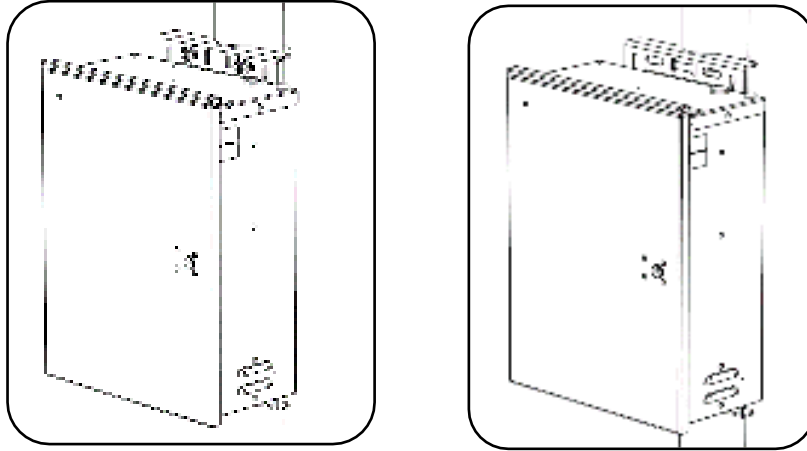

4. If desired, before tightening banding, brackets and banding can be adjusted inboard again (see below). Tighten banding (up to 3/4" wide) as per banding manufacturer's instructions.

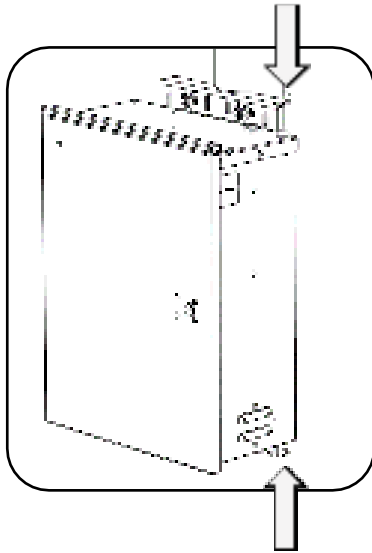

3.5 Overview of Cabinet Terminals

The G Series provides complete access to all electrical connection points that the installer will require when connecting power, fixtures, and other equipment. Each terminal block is introduced below.

NOTE Not all harnesses are be prewired by Carmanah.

NOTE Use ring terminals when connecting two or more wires to the same screw on a terminal block. For highest reliability of the electrical connection, do not stack spade terminals.

Harnesses are attached within the cabinet at various points using cable ties for strain relief and cable management. Attachment points may include adhesive cable tie bases, screw mount cable ties, and “dog bones.”

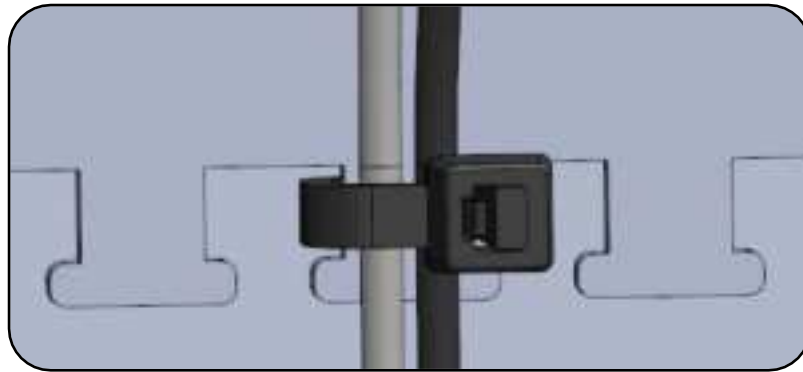

LED Terminal Block

The LED terminal block is a 16-position connector for attaching the light bars, circular beacons, and LED signs. The 16 connections are arranged in four “LED groups” of four connections per group.

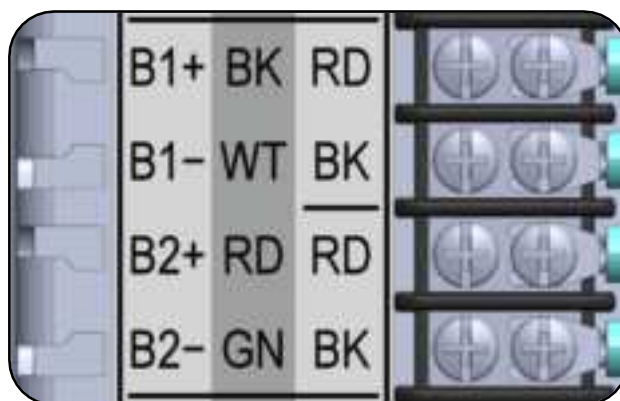
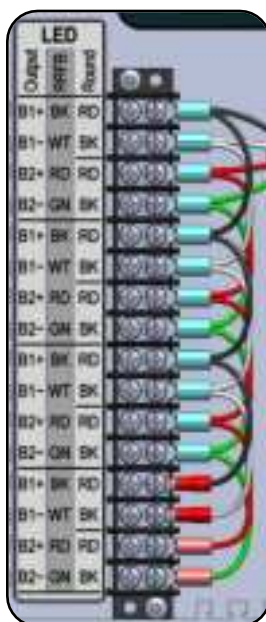

An LED group can be used to wire one light bar, two circular beacons or two LED signs. Each LED group has a Bank 1 pair (positive and negative) and a Bank 2 pair. Alternating flash patterns cycle back and forth between Bank 1 and Bank 2. If the flash pattern is set for unison and there are fixtures attached to both Bank 1 and Bank 2, both fixtures will flash in unison even though they are on different banks.

All four LED Groups are wired in parallel. That is, all B1+ are wired together, all B1- are wired together, and so on.

NOTE The EMS is pre-configured for the load type and color specified at time of order as indicated on the checkboxes next to the User Interface. Ensure the connected loads match the label.

NOTE The bottom four crimped terminals differ in appearance but there is no functional difference between these fixture connection points and the others above.

NOTE Because of the parallel connections between the four LED Groups, when a given bank is flashing, the current from the EMS LED driver will divide up among the fixtures attached to that bank.

The LED terminal block label provides the colors of the fixture wires that are to be connected at each terminal:

| Fixture | Label Marking | Wire Color | Bank |
|-----------------|---------------|------------|-----------|
| Light Bar | BK | Black | B1+ |
| | WT | White | B1- |
| | RD | Red | B2+ |
| | GN | Green | B2- |
| Circular Beacon | RD | Red | B1+ / B2+ |
| | BK | Black | B1- / B2- |
| LED Sign | RD | Red | B1+ / B2+ |
| | BK | Black | B1- / B2- |

Input/Output Terminal Block

The Input/Output terminal block is where input/output signal, switched control voltage, and unswitched supply voltage connections are made. The top six positions on the Input/Output terminal block are always prewired to the EMS by Carmanah. Position six and seven (DC-) are connected in parallel via a jumper. Position 8 is prewired only when the optional DC Relay Kit is ordered.

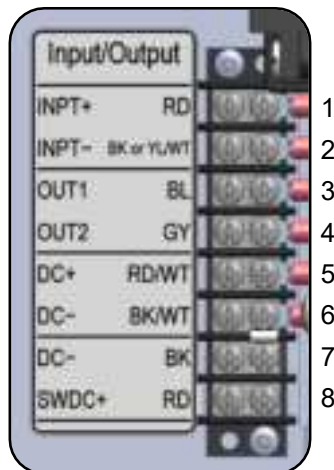

Related functions within the Input/Output terminal block are grouped together:

| | |
|--------------|---|
| INPT+ | These are the hardware push button or switch inputs that are referenced in the INPT (Input) section of the user interface instructions. Multiple connections are made in parallel. For information on configuring the behavior of the INPT terminals, see Input Type in Section 6.1 . |
| INPT- | |
| OUT1 | Used for Applied Information time switches only. Pulses of voltage (relative to DC-) indicate the system is operating with no detected fault. |
| OUT2 | This terminal provides a steady +12 V (nominal, relative to DC-) signal whenever the fixtures are activated and no faults are detected. See note below regarding OUT2 load voltage and current considerations. For information on configuring, see Digital Output in Section 6.1 . |
| DC+ | The DC+ / DC- terminals provide 12V DC to power devices such as third-party time switches (15V DC on AC-powered systems). |
| DC- | |
| DC- | The DC- terminal is bridged to the DC- terminal above. |
| SWDC+ | Wired to output of DC solid state relay for units with optional DC Relay Kit, see Section 5.7 . |



Due to the variety of devices and fixtures that can be connected at the Input/Output terminal block, the color assignments shown on the terminal block label may not be correct in all cases. Please confirm correct connectivity and polarity for each fixture or device type.



The push button input (INPT+, INPT-) is not a dry contact type. There is always 12-15VDC present between these terminals, regardless of input configuration (NO, NC, or Button, see [Section 6.1](#)). When connecting input devices other than standard traffic push buttons, consideration must be given to electrical compatibility. Failure to isolate input signals operating at different voltages or connection of devices that are designed to operate in a different voltage range could result in poor performance or equipment damage. Please contact Carmanah for additional support on connection of non-standard input devices.



The voltage available at the OUT2 terminal changes depending on the current flowing through OUT2. See [Digital Output](#) in [Section 6.1](#).

DC Input Power Terminal Block

The DC Input Power terminal block is where input power arrives within the G Series cabinet, passes through fusing, and then continues on to the EMS through two 15A fuses. The G Series operates on nominal 12-volts DC power, which is provided either by a battery and solar panel in solar-powered systems, or an AC/DC power supply in AC-powered systems. Note the polarity of the terminals which have been laid out to maximize the distance between positive and negative and prevent accidental shorting.

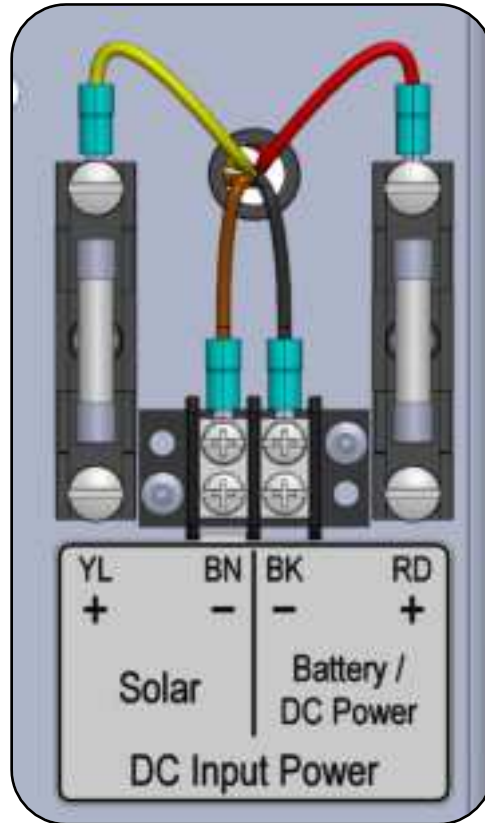

Use the following table when connecting the solar panel harness to the DC Input Power Terminal Block:

| Polarity | Solar Panel Harness | DC Input Power Terminal Block |
|--------------|-----------------------------------|-------------------------------|
| Positive (+) | Red wire with yellow heat-shrink | YL+ (Yellow wire to EMS) |
| Negative (-) | Black wire with brown heat-shrink | BN- (Brown wire to EMS) |

3.6 Installation of Cabinet Terminals

1. Install push button harness: connect red push button wire terminal to INPT+, black push button wire to INPT-, torque terminal screws to 12 in-lb.

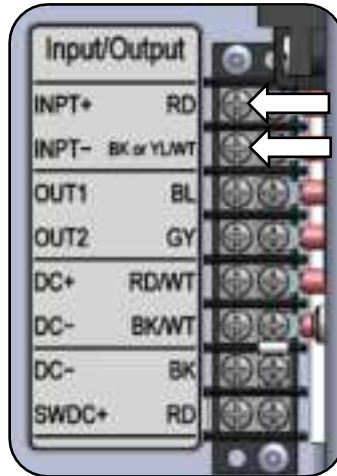

2. Install flashing beacon harnesses:

- For round beacons and LED-enhanced signs, match the red/black wires to the RD/BK text in the Round column of the LED label.
- For RRFBs, match the black/white/red/green wires to the BK/WT/RD/GN text in the RRFB column of the LED label.
- Torque screws to 12 in-lb and secure cable jackets to chassis with cable ties.

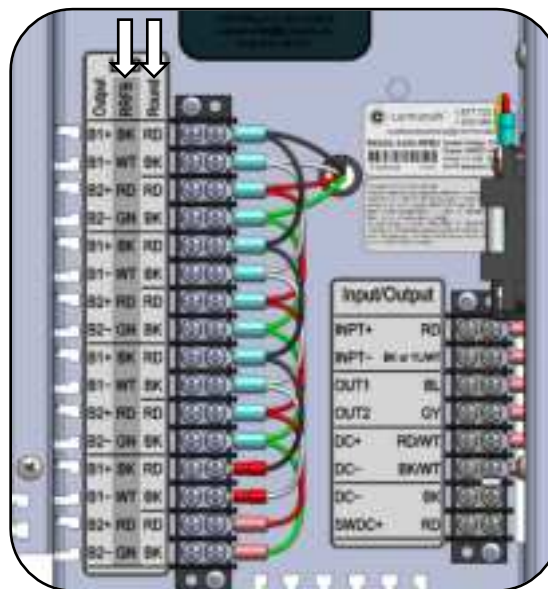
NOTE

All B1+ terminals are wired in parallel. Similarly, all B2+ terminals are wired in parallel. As a result, all beacons wired to B1+/- terminals will flash together and beacons wired to B2+/- will flash together.

- For **Solar** systems: remove Solar and Battery/DC Power fuses from fuse holders on right side of cabinet and connect solar panel harness terminals: red wire with yellow heat shrink to YL +, black wire with brown heat-shrink to BN.



ELECTRICAL SHOCK HAZARD. DO NOT LET THE BATTERY TERMINALS COME INTO CONTACT WITH ANY EXPOSED METAL.



Batteries are shipped fully charged. Use extreme caution when handling the batteries as they can generate hazardous short-circuit currents. Remove all jewelry (bracelets, metal-strap watches, etc.) before attempting to handle the batteries.

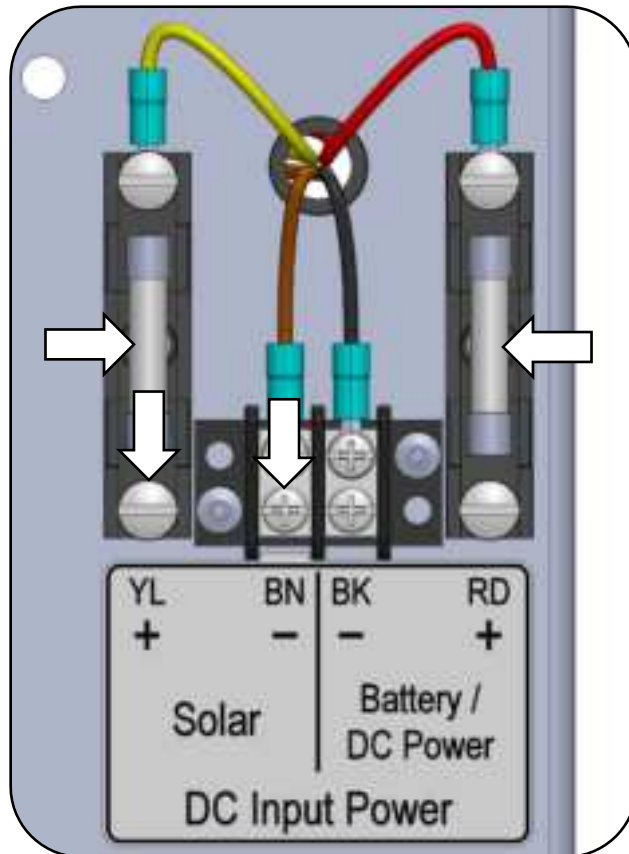

- For Solar systems: install battery into cabinet with terminals toward you. Install ring terminal on red battery wire to positive (+) battery terminal. Install ring terminal on black battery wire to negative (-) battery terminal.



Do not reinstall battery and solar fuses until all system wiring is completed.

5. For **AC** systems, ensure AC supply power is off.
6. For **AC** systems: turn breaker in cabinet off. Install supply ground into bus bar terminal shown, torque to 20 in-lb. Install supply line and neutral wires into AC Input terminals, torque to 6 in-lb. Secure cable jacket to chassis with cable tie.



ELECTRICAL SHOCK HAZARD. DO NOT ENERGIZE AC SUPPLY OR TURN CABINET BREAKER(S) ON UNTIL ALL SYSTEM WIRING IS COMPLETED.



The ground bus bar accepts 4-14AWG copper wire.
The DIN rail terminal blocks accept 10 – 26AWG copper wire.

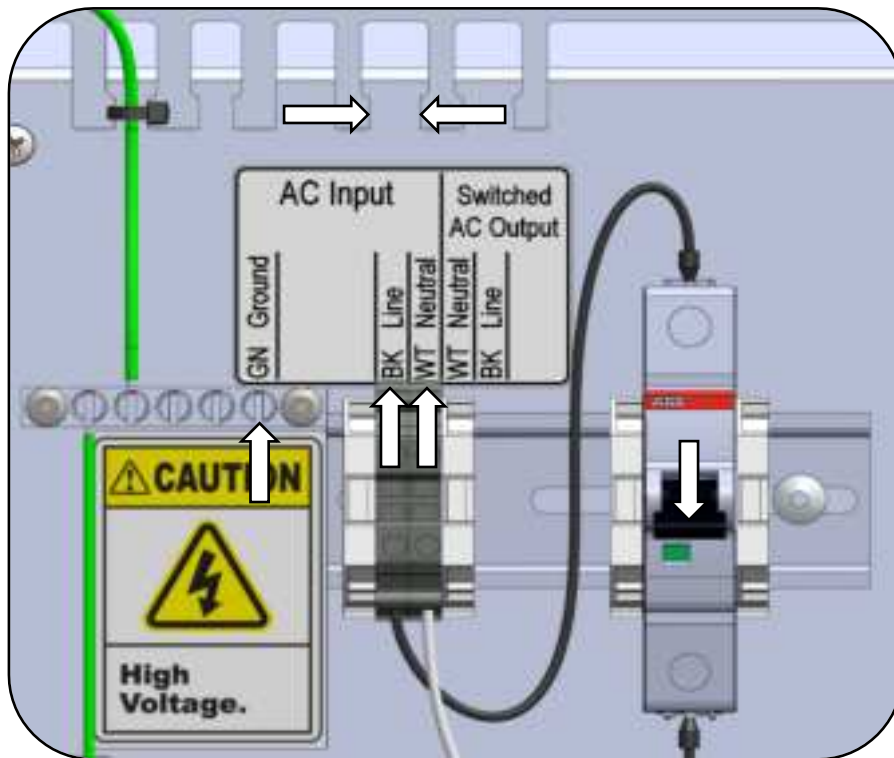

7. Proceed with installation of other system elements described in [Section 4](#) and [Section 5](#).



Ensure cabinet door is fully closed and latched otherwise damage may occur.



The cabinet can be ordered with an alternate padlockable latch for extra security.

4.0 Fixture and Push Button Installation

4.1 RRFB Light Bar Installation

1. Feed the light bar cable(s) through the post, creating a drip loop.

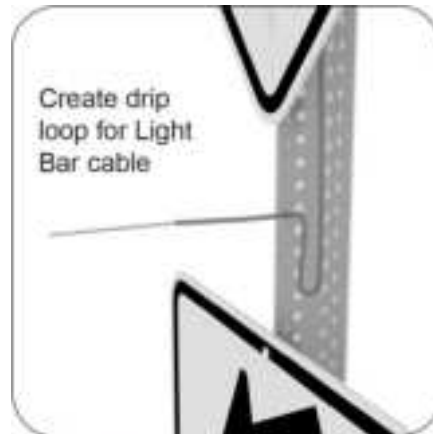

2. Mount the light bar universal bracket(s), feeding the light bar cable through the center of the bracket. Bolts and banding not supplied.

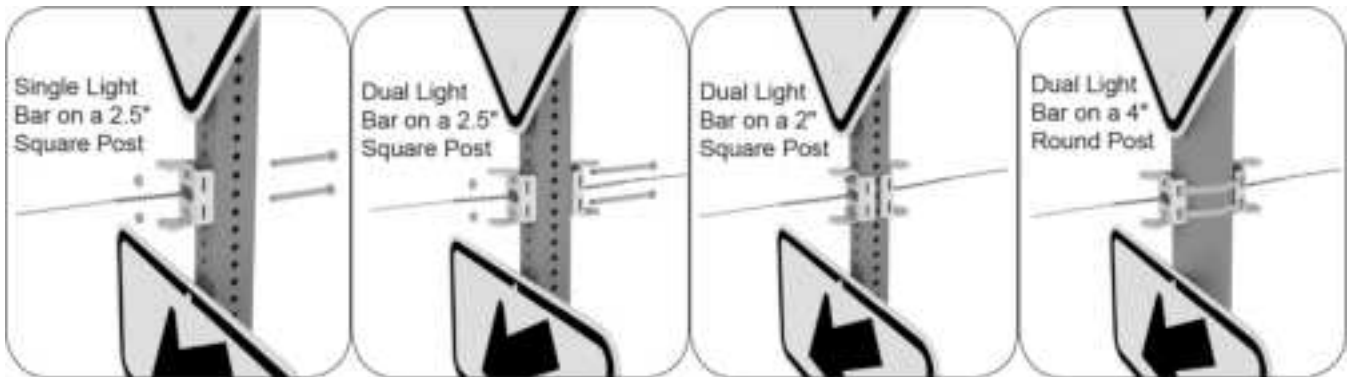

3. Mount the light bar(s) onto the universal bracket(s), feeding the light bar cable through the housing.

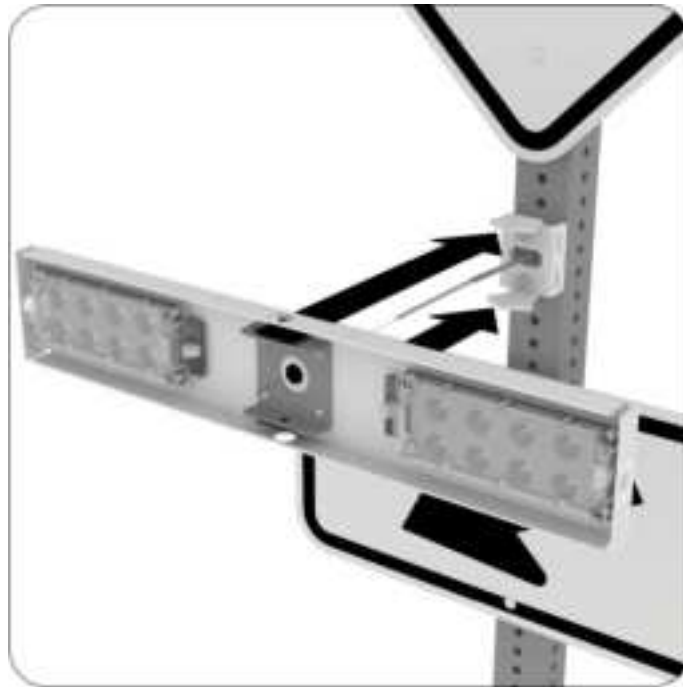

4. Bolt the light bar to the universal bracket as shown below.



5. Align the light bar toward the traffic as required. The angle can be adjusted +/- 3 degrees. Tighten mounting nuts to lock in place.



6. Secure the light bar cable using supplied cable ties as shown.

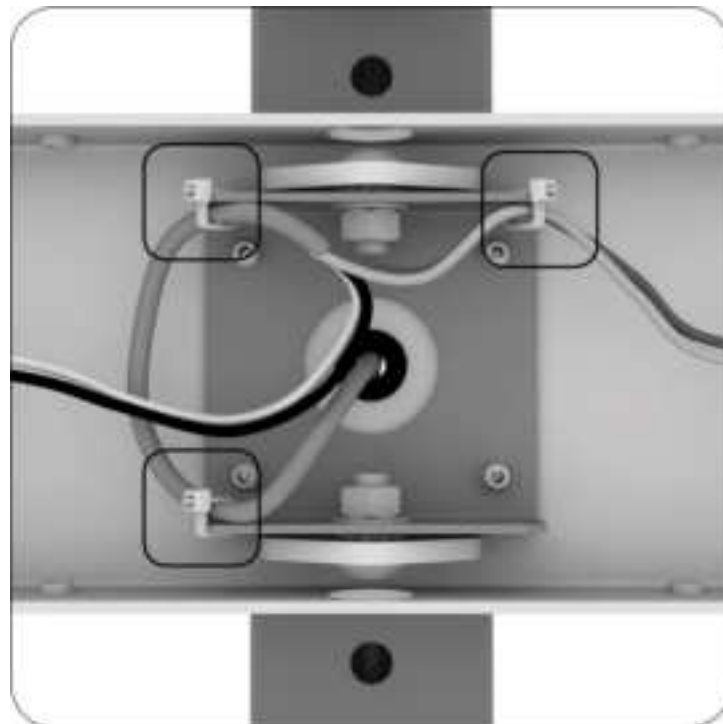

7. Push the light bar wires into the light bar connectors, following the color scheme as noted on the LEDs.

NOTE

Mount the light bar so that the black and white wires are on the left side. This ensures that the RRFB flash pattern, **which must start on the left**, is compliant with the FHWA requirements.

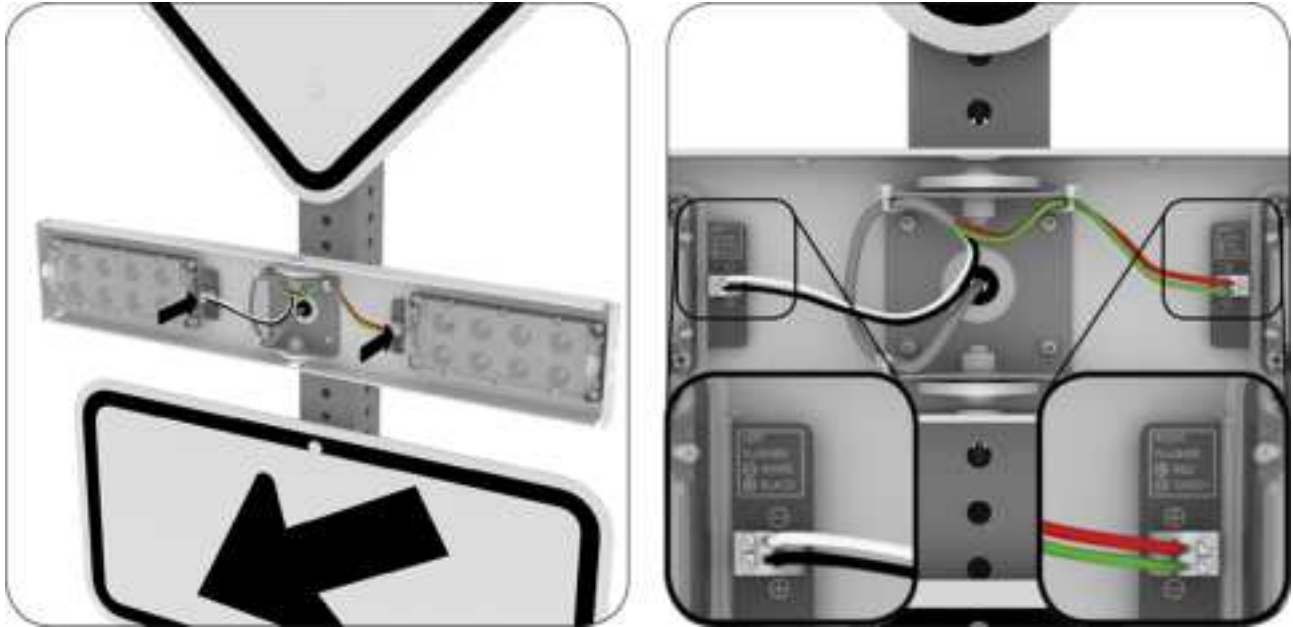

8. Slide on light bar cover and secure with the four provided #8 screws.

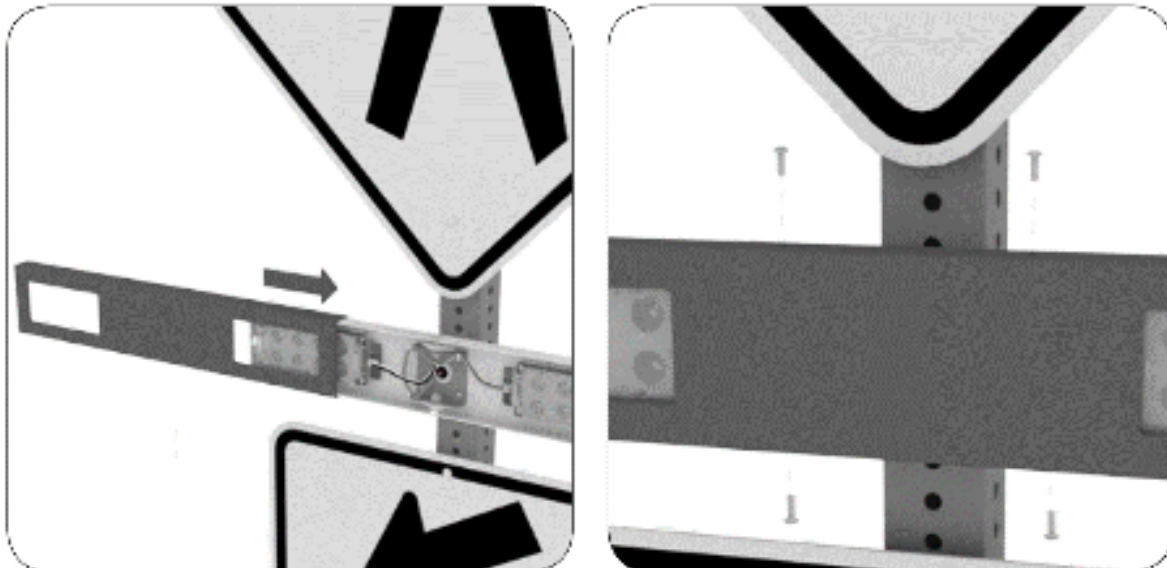
**NOTE**

Two additional #8 screws are provided to prevent vandals from twisting the light bar grossly out of alignment. These anti-vandal screws are installed through slots in the inner bracket into tapped holes in the outer bracket as shown below.

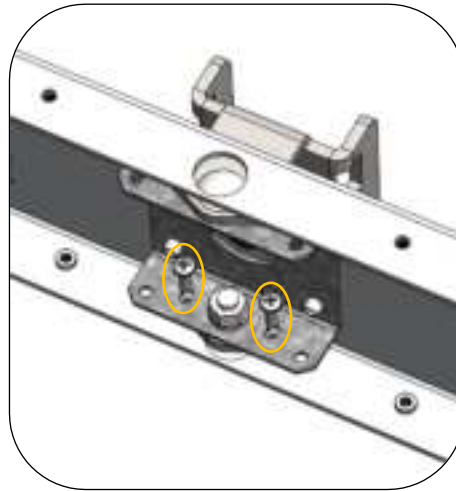

Locations of Anti-Vandal Screws

9. If the pedestrian confirmation light is not required in one direction, use the supplied opaque label to cover the indicator light.

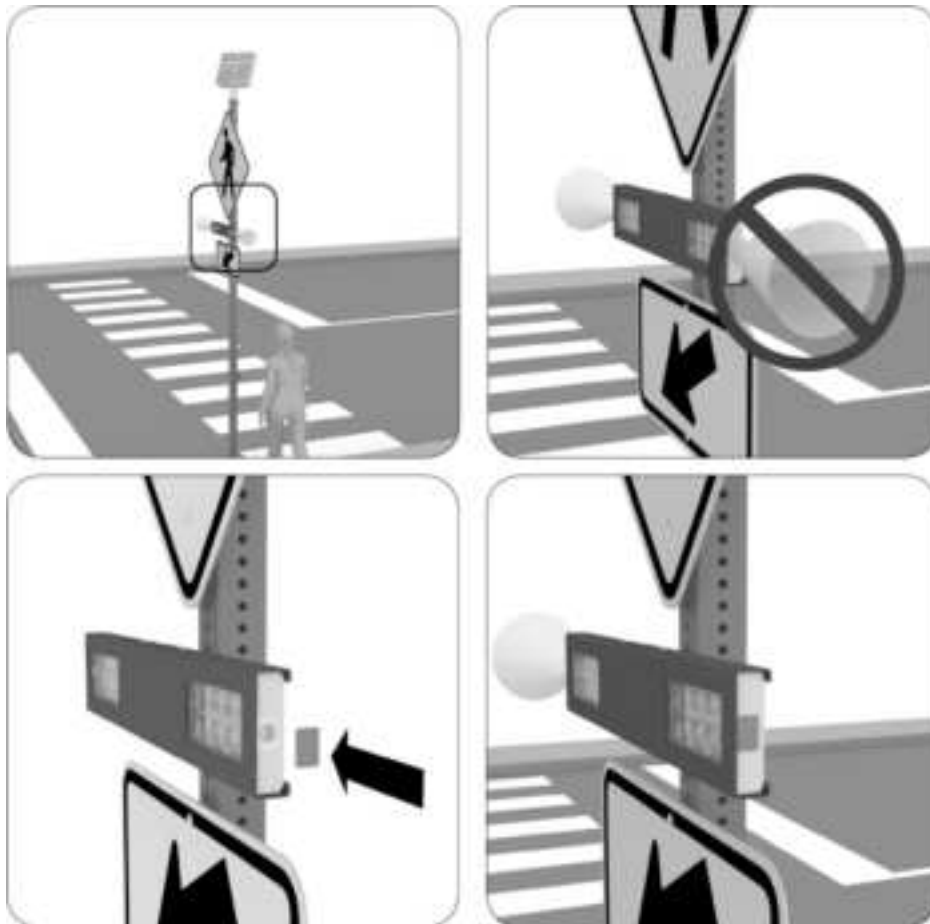

4.2 Circular Beacon Installation

1. Thread the flashing beacon harness through the beacon arms, making a drip loop in the pole (not shown). Mount the top flashing beacon arm to the pole using stainless banding or bolts (not supplied). Use the gasket on the top mounting arm to ensure water doesn't leak past the connection and enter the signal head from the top.

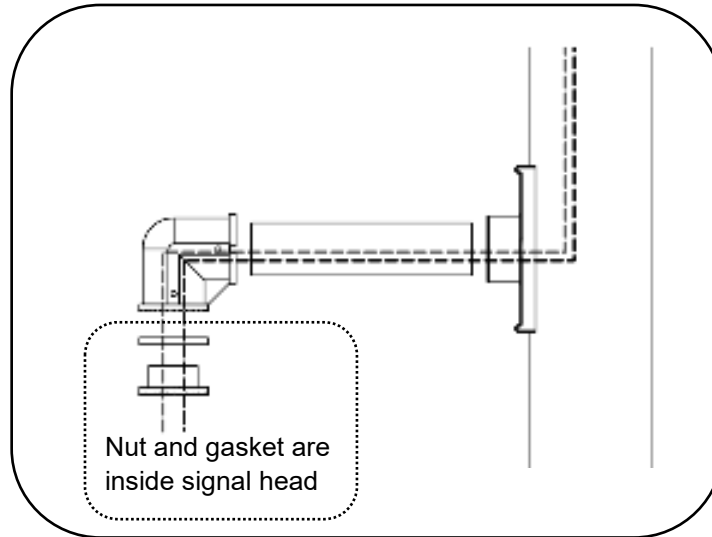

2. Connect the flashing beacon harness to the terminal block inside beacon housing according to the wire connection table below. Complete the flashing beacon assembly and attach the bottom arm mount to the pole using stainless steel banding or bolts (not supplied).

| LED WIRE CONNECTIONS | | | |
|-----------------------------|----------------|---------------------|------------------|
| Polarity: | Wire from EMS: | Wire to Yellow LED: | Wire to Red LED: |
| + | Red | Yellow | Red |
| - | Black | White | White |

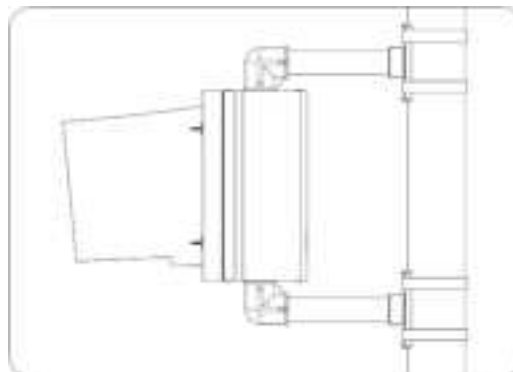

4.3 LED Enhanced Sign Installation

LED enhanced signs can be mounted in different ways:

- Through-bolted to standard perforated square post or wing channels.
- Through-bolted to drilled round posts.
- Banded to round or irregularly shaped posts using optional banding brackets.
- U-bolted to different round posts using the optional pre-installed Z-bar Kits and appropriate U-bolts.

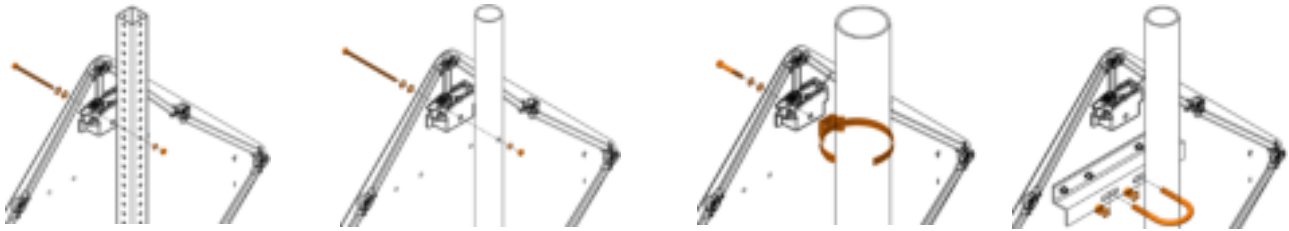

1. Mark the top mounting hardware location on the post and the cable exit location 2" above it. If through-bolting to a solid post, also mark the bottom hole location. Refer to table below for bolt spacing for the specific type and size of sign being installed.

| SIGN SIZE AND SHAPE | HOLE SPACING | DISTANCE FROM TOP EDGE |
|---------------------------|--------------|------------------------|
| 24" DIAMOND | 21 | 5.85 |
| 30" DIAMOND | 29 | 5.94 |
| 36" DIAMOND | 37 | 6.02 |
| 48" DIAMOND | 48 | 8.7 |
| 24" STOP | 18 | 2.2 |
| 30" STOP | 24 | 2.33 |
| 36" STOP | 30 | 2.45 |
| 48" STOP | 40 | 2.83 |
| 30" YIELD | 15 | 2.63 |
| 36" YIELD | 20 | 2.76 |
| 48" YIELD | 28 | 3 |
| 60" YIELD | 36 | 3.5 |
| 30" SCHOOL ZONE | 20 | 6.22 |
| 36" SCHOOL ZONE | 25 | 7.07 |
| 48" SCHOOL ZONE | 34 | 8.76 |
| 30X18" WRONG WAY | 13 | 2.63 |
| 36X24" WRONG WAY | 18 | 2.88 |
| 42X30" WRONG WAY | 23 | 3.13 |
| 24x48" School Speed Limit | 42" | 1.9" |

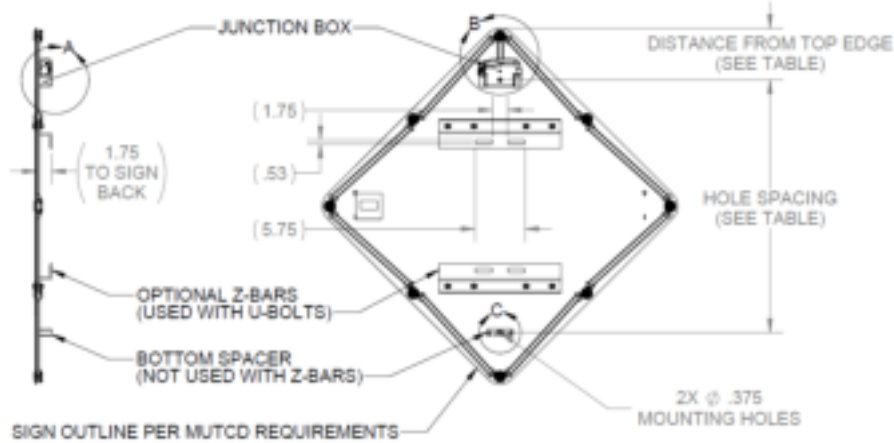

2. Drill or enlarge and deburr cable exit hole to 3/4" diameter at the marked location on post or pole. Drill top and bottom 3/8" diameter mounting holes if required.
3. Feed cable through cable exit hole, creating a drip loop, and secure out of the way. 10" to 12" of cable should protrude from the post.

NOTE The cable can be led through existing 3/8" holes in standard square posts but care must be taken to align the junction box entry hole as closely as possible when tightening the sign down to prevent damage to the cable and ensure the junction box lid fits properly. Enlarging the existing hole to 3/4" is recommended.

NOTE The cable can also be fed later but it is easier to do so before the sign is mounted to the post.

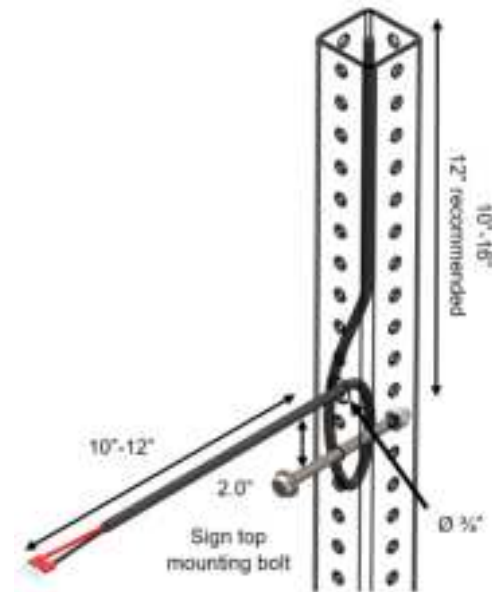

4. Loosen the junction box cover retaining screw by a few turns and slide the cover off, set aside. Ensure that the zip tie is in place and open before mounting sign to post.

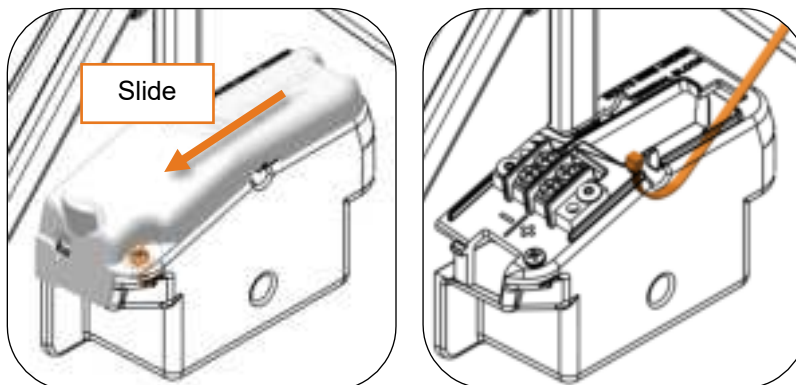

- Mount the sign to the post using compatible 5/16" hardware. Ensure hardware is in correct order—starting with bolt, flat washer, nylon washer—so that the nylon washer is directly against the sign sheeting. Ensure that the cable entry hole in the post is aligned with the junction box cable entry hole, especially for U-bolted or banded signs.

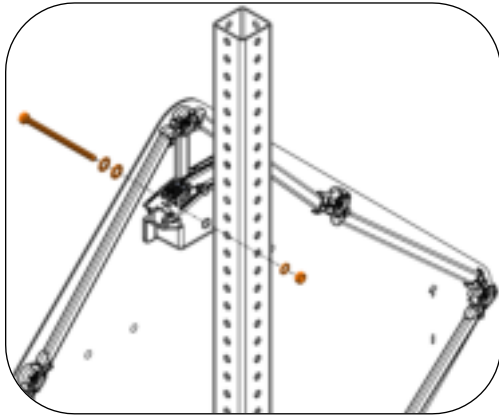

Through-bolted to square post

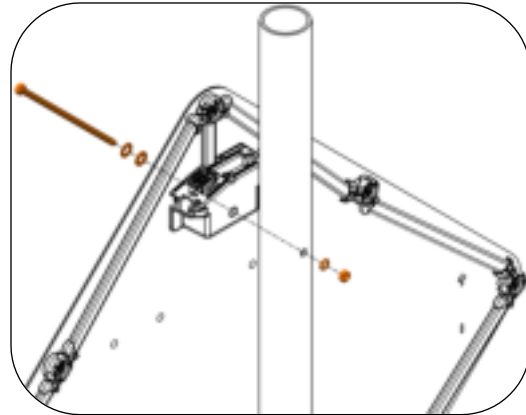

Through-bolted to round post (drilling required)

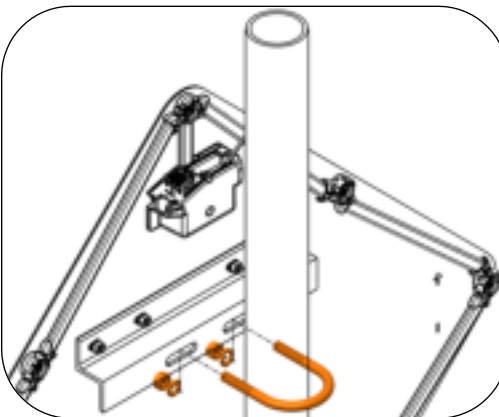

Z-bracket sign U-bolted to post

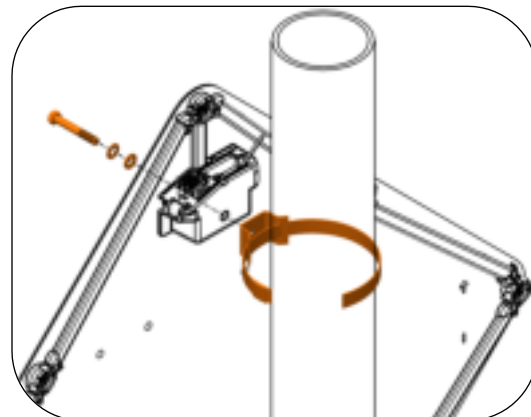

Banded to post

NOTE If supplying your own hardware, note the larger than typical thickness resulting from the integrated junction box.

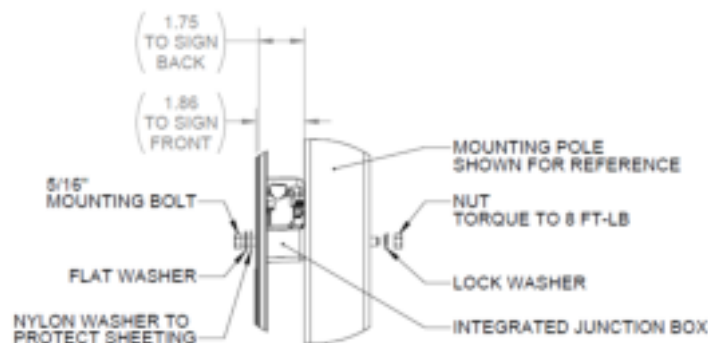

- Route cable in junction box as shown and connect wires respecting polarity: red to “+” and black to “-”. Loop the excess cable in the junction box as shown (push some back in the post if necessary). Tighten and trim supplied cable tie to secure cable (sign hidden for clarity).

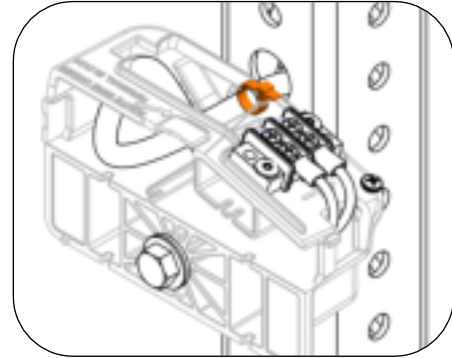
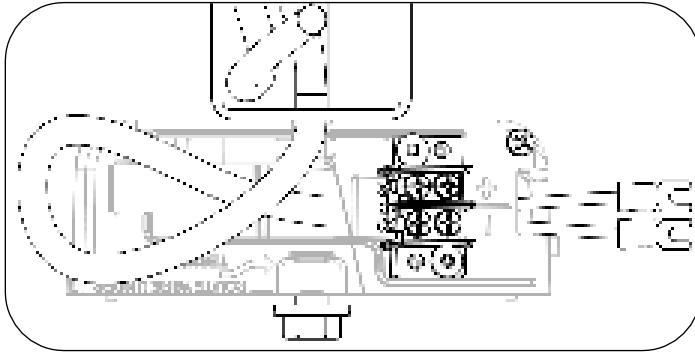
**NOTE**

The cable or cable tie may interfere with the junction box cover if they are not secured and trimmed properly.

- Reinstall the junction box cover and secure it in place by tightening the screw lightly (do not over-tighten).



4.4 Push Button Installation

**NOTE**

If the system is wired for a push button but one is not required (such as an advance RRFB), insulate the ends and secure the wires.

NOTE

ADA regulations specify that the button should be 42" from the ground.

NOTE

The push button can be connected in either polarity.

NOTE

The recommended maximum number of Polara Bulldog push buttons that can be connected in parallel is 2.

1. Prepare post according to button manufacturer's installation instructions. Deburr hole that push button wiring will pass through.
2. Feed push button cable through pole, creating a drip loop.

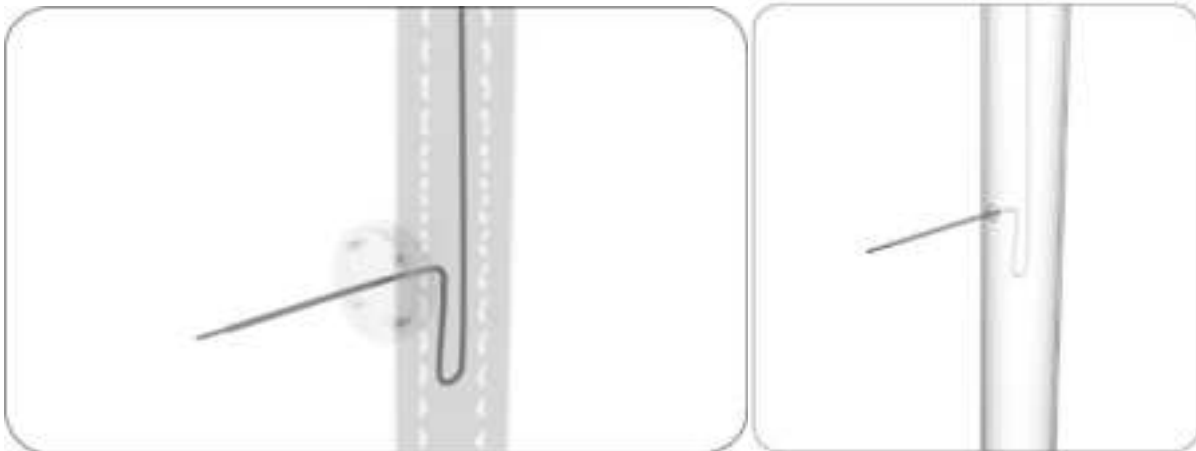

3. Mount the push button to the post, connecting the wires to the push button.

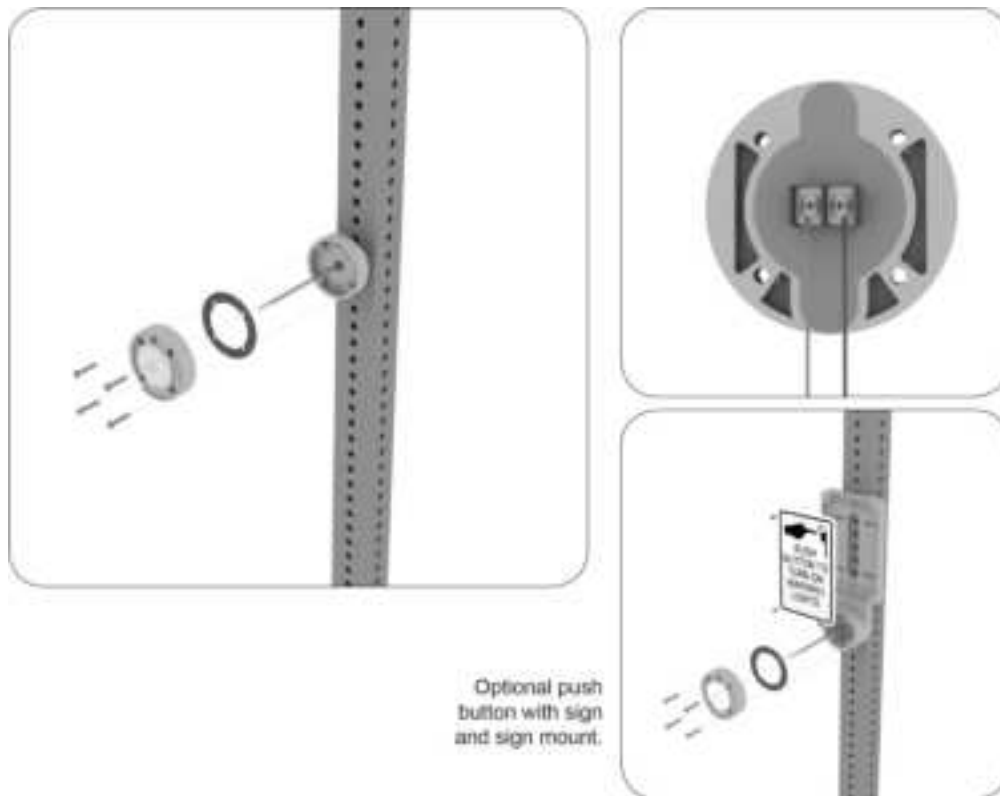

4. Attach the button mounting adapter to the pole, connect the button cable to the button, and attach the button to the mounting adapter.

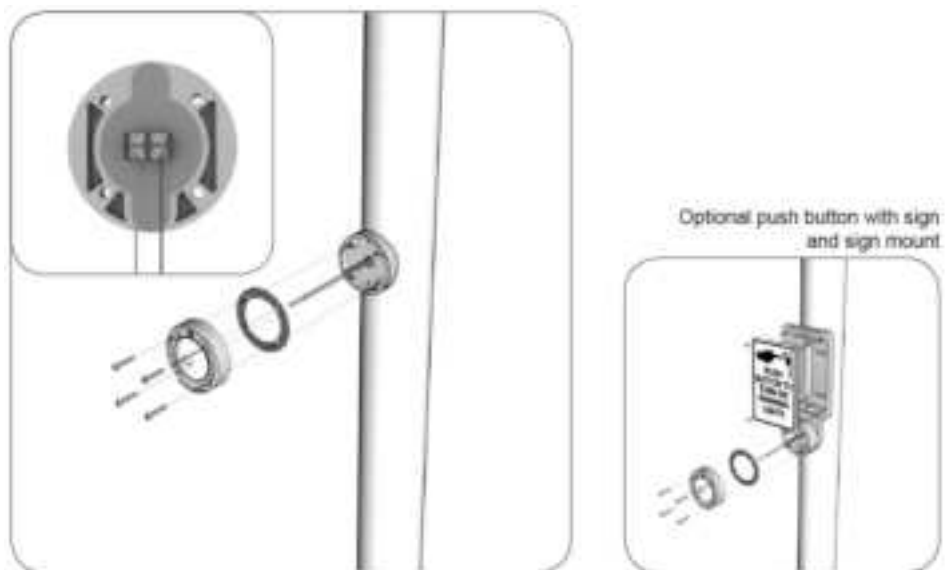

4.5 Energizing the System

Once all the system elements and harnesses are installed, the system can be energized.

Solar-Powered Systems:

1. Install the battery fuse.
2. Install the solar fuse.

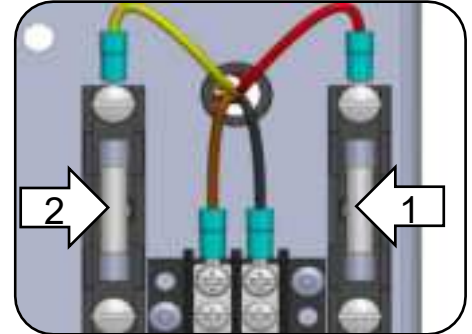

AC-Powered Systems:

1. Turn on the supply power.
2. Turn on the breaker(s) in the cabinet.

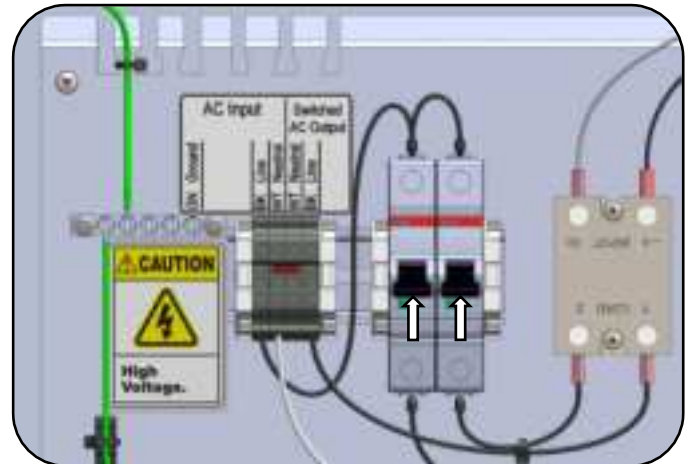

Solar and AC Systems:

3. The system will energize and the user display will become active. If it is part of a radio-connected group, all members of the group will now be able to communicate with each other. See the [Section 6.0](#) to adjust default settings and to perform system testing and commissioning.
4. Close the cabinet to complete installation. Ensure the solar panel is facing the equator (pointing south if you are in the Northern Hemisphere).



Ensure cabinet door is fully closed and latched otherwise damage may occur.



Disconnect power by removing system fuses before installing any additional equipment or accessories.

5.0 Installation of Optional Accessories

5.1 Calendar Upload / Override Switch Kit Installation

The R829 and R247 are available with a lockable pole-mounted manual override box that is mounted lower down on the mounting structure to allow easy access by individuals on the ground. The override box is used for forcing the R829 to flash regardless of the calendar schedule and for forcing the R247 to temporarily cease flashing. For R829 systems, this box will also contain the USB connection for programming the internal calendar. The USB cable is used to communicate calendar data between the R829 and a windows PC. The override box can be mounted on 2" square perforated and round poles. Assembly required.

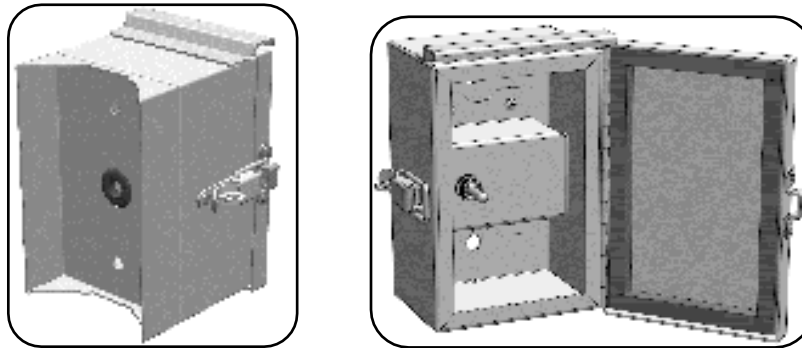

Calendar Upload / Override Switch Kit

When used with the G Series, the Override Switch Kit comes with a harness that connects to the INPT+ and INPT- terminals of the EMS and the switch terminals at the override box end.

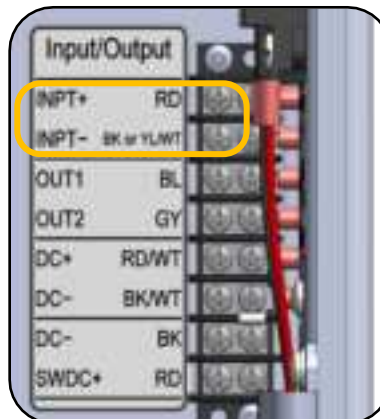

NOTE

For calendar-equipped systems, another related kit is the Calendar Software Programming Kit, which includes a USB memory stick containing the School Zone Calendar Configuration Windows application and a 32-foot active USB extension harness. The USB extension allows programming from a distance from the pole—for example, from a laptop within a work vehicle parked nearby.

5.2 RTC Time Switch Installation

NOTE

This product configuration requires the RTC/IDC Time Switch Kit (time switch not included). Contact Carmanah for assistance if the system is being converted from non-school zone application, or for general information on installing third-party devices.

1. Open cabinet and remove screws from three standoffs shown. Remove fourth standoff if present. Ensure standoffs are in the correct positions (see [Section 5.5](#) for details). Remove lid from time switch. Install onto standoffs with three screws as shown. Replace switch cover. Mate harness from EMS.

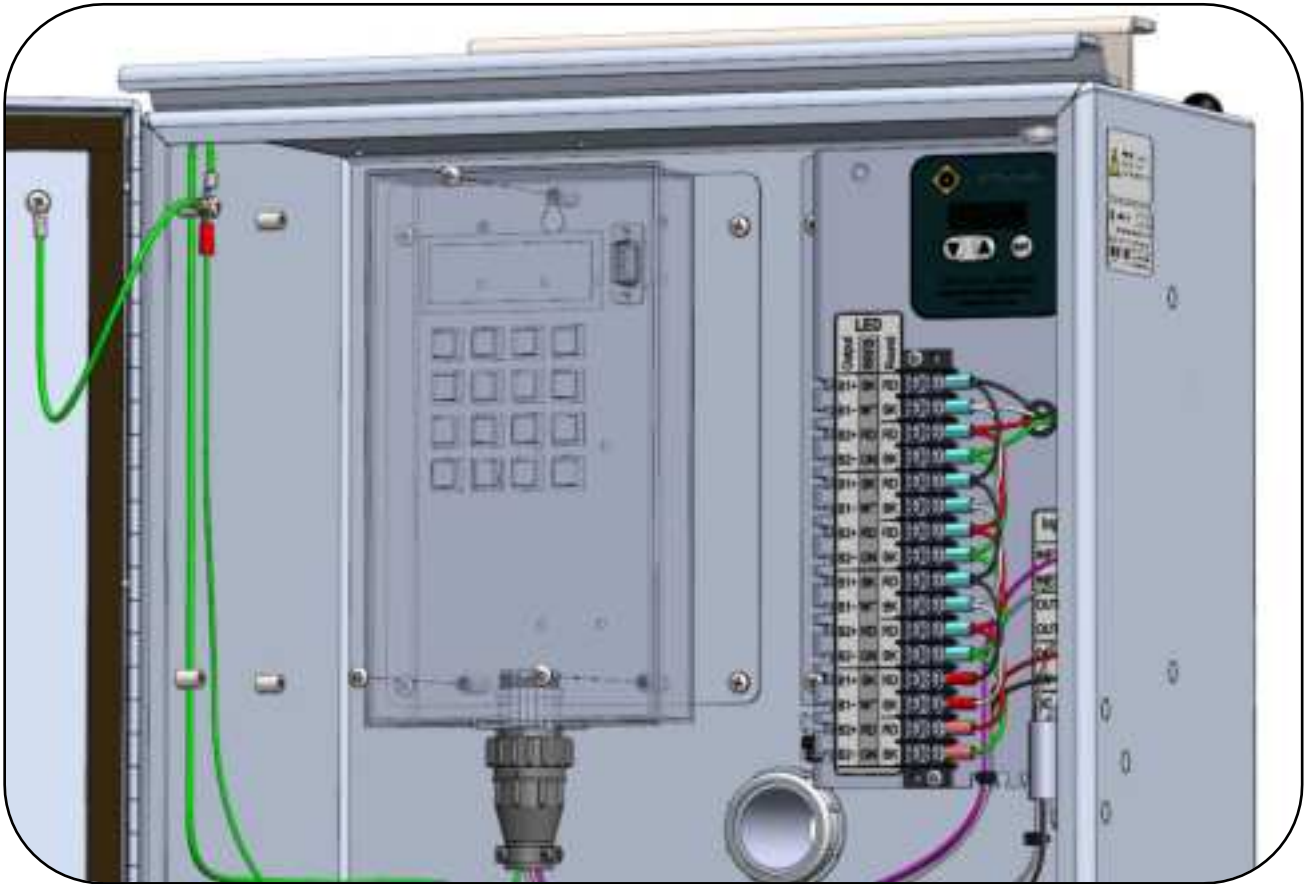

2. Follow manufacturer's instructions for configuration of Time Switch.

5.3 Information Display Company Time Switch Installation

NOTE

This product configuration requires the RTC/IDC Time Switch Kit (time switch not included). Contact Carmanah for assistance if the system is being converted from non-school zone application, or for general information on installing third-party devices.

1. Open cabinet and remove four screws holding time switch plate to back of cabinet. Remove screws from standoffs and remove standoffs from plate.

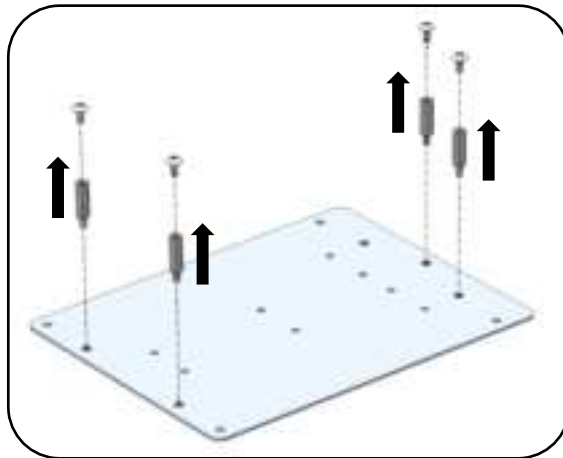
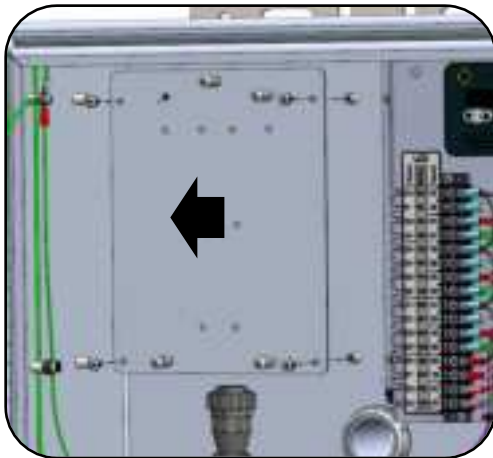

2. Thread three standoffs into bottom of IDC switch. Fasten IDC switch with standoffs to plate with screws as shown (see [Section 5.5](#) for details). Fasten plate/switch assembly into cabinet using 4 screws. Mate harness from EMS.

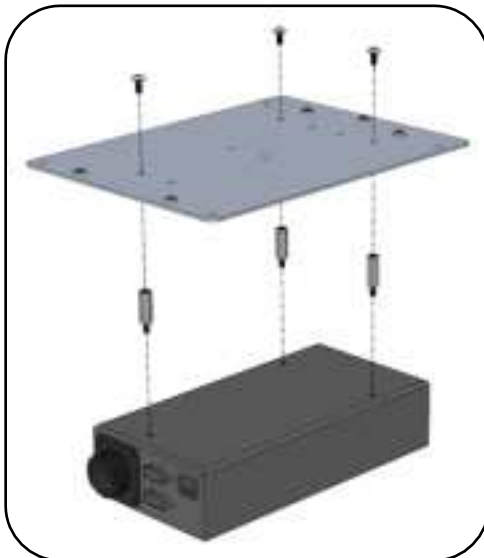

3. Follow manufacturer's instructions for configuration of Time Switch.

5.4 Applied Information or FCU Modem Kit Installation

NOTE

This product configuration requires the optional Applied Information Modem Kit (modem not included). Contact Carmanah for assistance if the system is being converted from non-school zone application, or for general information on installing third-party devices.

NOTE

Applied Information models FCU-500-070B (not available in Florida) and FCU-500-071B (only available in Florida) have been optimized specifically for Carmanah's G Series.

G Series systems ordered with the Applied Information Modem Kit will have a compatible harness prewired to the terminal blocks. The Applied Information time switch can monitor the solar panel voltage and battery voltage and remotely report the values on the Applied Information *Glance* platform.

1. Remove four screws from cabinet standoffs as shown. Set aside.

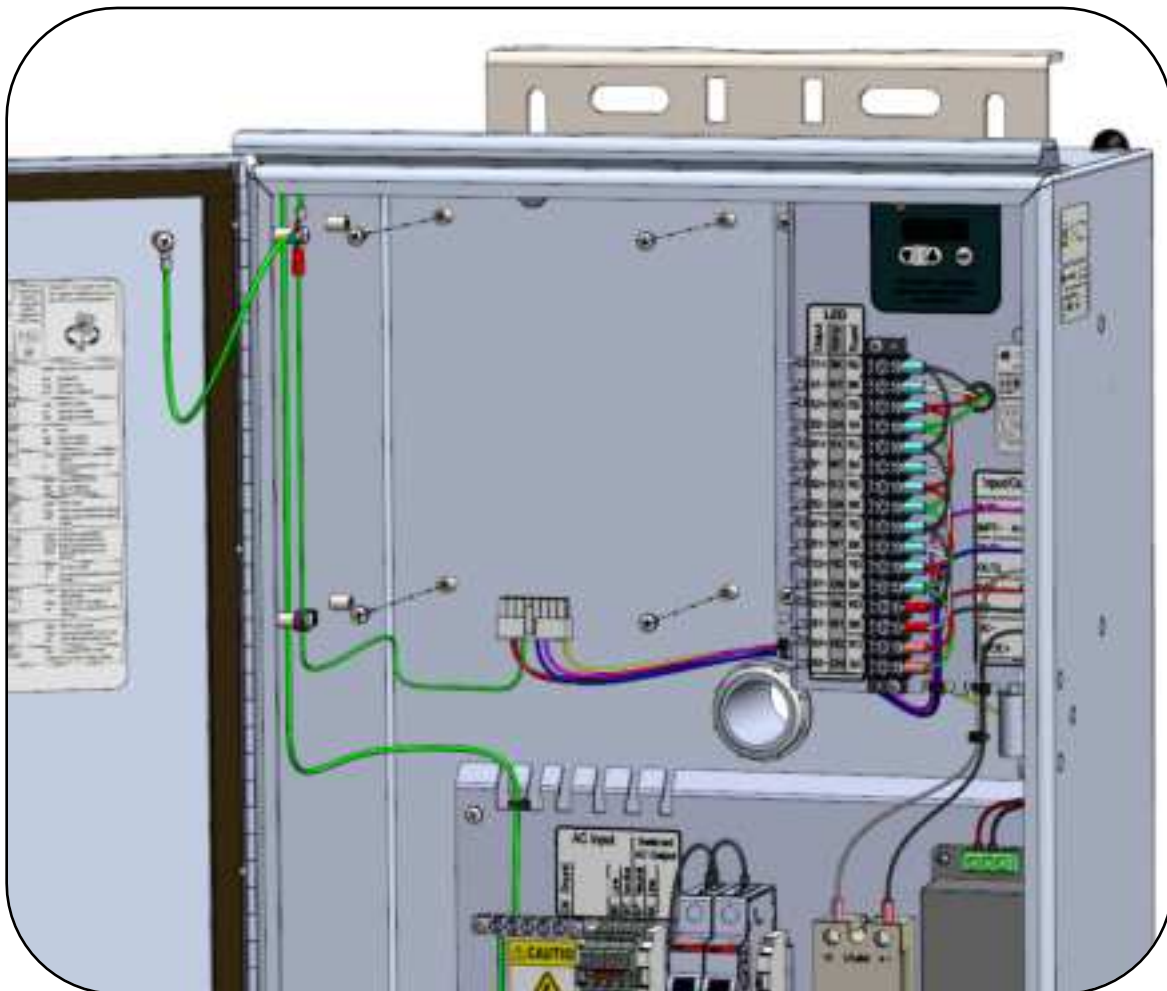

2. If an antenna is to be used, locate indentation near center of top surface of cabinet and use it to locate and drill a 1/2" dia. hole. Deburr hole, clean chips, and install antenna, plastic washer, lock washer, and nut as shown.

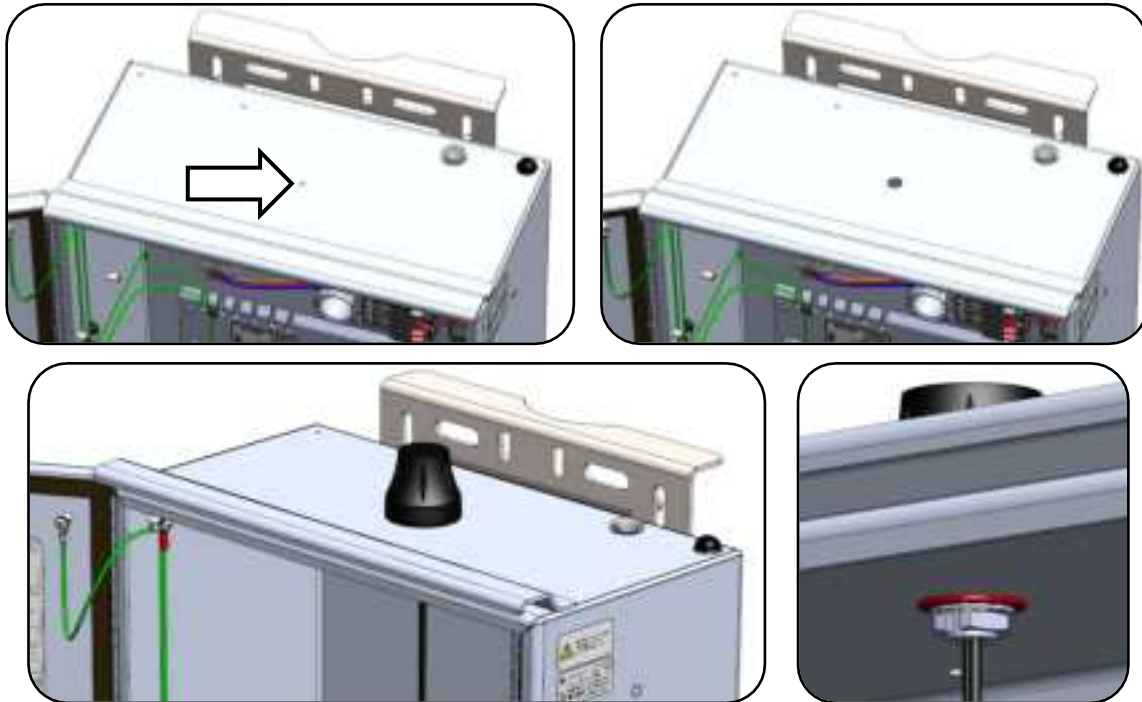

3. Fasten AI unit into cabinet using four screws removed in step 1. Mate rectangular connector from EMS and coax connectors from antenna (if used).

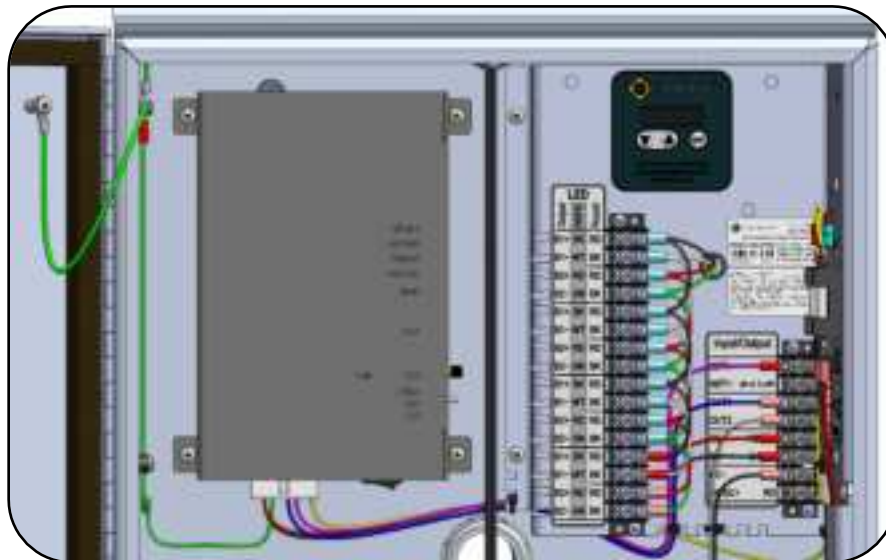

4. Follow manufacturer's instructions for unit configuration.

5.5 3PD Time Switch Supplementary Information

1. 3PD mounting plate layout

The G Series 3PD adapter mounting plate included with the various 3PD kit options has holes to accommodate a variety of third-party devices. These are summarized in the table and diagram below.

| Application | Holes Used | Installation and Wiring Notes |
|---------------------------------------|------------|---|
| 3PD adapter mounting plate to cabinet | 1, 2, 3, 4 | |
| AI FCU 500 | 1, 2, 3, 4 | Four provided screws go through holes in AI unit and into standoffs in cabinet. No adapter mounting plate needed. |
| RTC AP21, CPR2102, AP22 | 9, 6, 8 | Standard wiring versions. TxDOT version requires removal of several contacts from provided harness connector using TE extraction tool 305183 and reinstallation into different positions: Relay pins 4 and 10 are reversed. DC+ moves from pin 15 to pin 11. DC- moves from pin 13 to pin 12.* |
| IDC DC-FB (BT 5000) | 11, 12, 13 | Standoffs go into switch, screwed onto plate from below. |
| Encom WBCU | 5, 6, 7, 8 | |
| Eltec TC-18 | 9, 6, 8 | Requires removal of several contacts from provided harness connector using TE extraction tool 305183 and reinstallation into different positions: DC+ moves from pin 15 to pin 11. DC- moves from pin 13 to pin 12.* |

*Consult manufacturer's documentation to confirm.

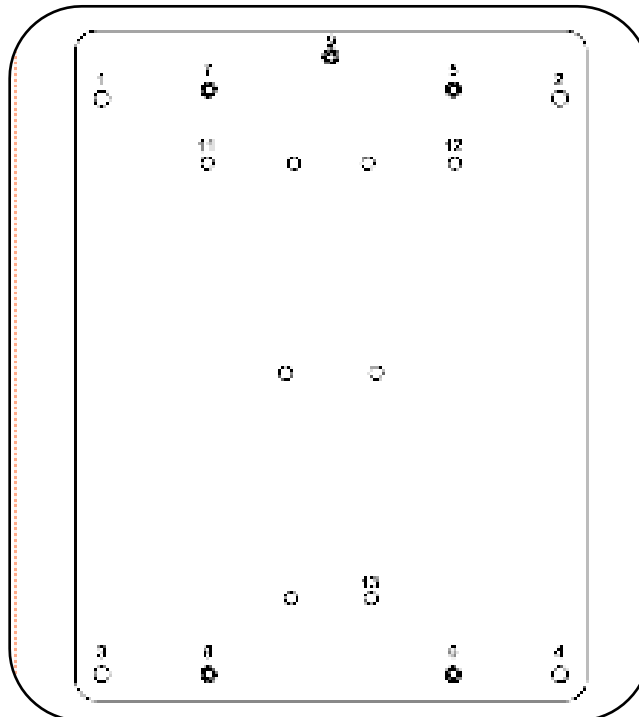

3PD Adapter Mounting Plate

2. Pin assignment in circular connector provided with RTC/IDC Time Switch Kit

| POSITION # | WIRE COLOR | FUNCTION |
|------------|------------|----------------|
| 3 | GREEN | CHASSIS GROUND |
| 4 | SLATE | RELAY 1 COMMON |
| 10 | VIOLET | RELAY 1 N/O |
| 13 | BLACK | DC NEGATIVE |
| 15 | RED | DC POSITIVE |



CONNECTOR VIEW FROM
WIRE ENTRY SIDE

3. Pin assignment in rectangular connector provided with AI Time Switch and Modem kit:

| POSITION # | WIRE COLOR | FUNCTION |
|------------|------------|----------------|
| 1 | YELLOW | PV POSITIVE |
| 6 | GREEN | CHASSIS GROUND |
| 7 | BLACK | DC NEGATIVE |
| 11 | VIOLET | BEACON CONTROL |
| 12 | BLUE | ALARM |
| 15 | RED | DC POSITIVE |

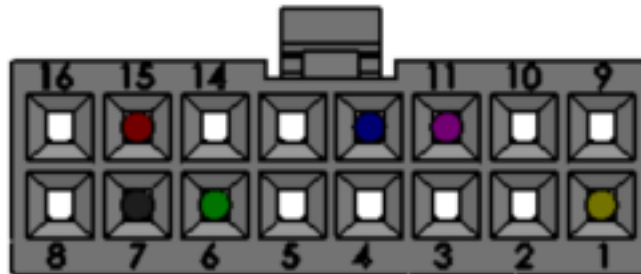

CONNECTOR VIEW FROM
WIRE ENTRY SIDE

5.6 AC Relay Kit Installation



For solar-powered systems, it is important to discuss your application with a Carmanah representative to ensure your load will operate sustainably in your location. Shade analysis is highly recommended for understanding how solar access will change according to the time of year. Contact Carmanah for a detailed examination and solar simulations for your site.

The G Series AC Relay Kit option includes a pre-installed AC/DC relay. The relay input is prewired to the OUT2 output of the EMS. The relay AC load side is wired to the Switched AC Output terminals through a 4A breaker. When the EMS LED output turns on, the digital output on the EMS is enabled and the output terminals of the relay close to operate an AC load.



The behavior of the Output is modified by the output setting on the EMS. When set to “nite”, the output will only be enabled when the LED output is on and at nighttime. See [Section 6.1](#) for details.



ELECTRICAL SHOCK HAZARD.

DO NOT ENERGIZE AC SUPPLY OR TURN CABINET BREAKER(S) ON UNTIL ALL SYSTEM WIRING IS COMPLETED.



The relay model supplied with the AC Relay Kit is Omron part number G3NA-210B-DC5-24. Please see Omron's datasheet for more information.

To install an AC load:

1. Turn off the AC supply to cabinet.
2. Turn off breakers in cabinet. Install ground from AC load cable into bus bar terminal shown, torque to 20 in-lb. Install line and neutral wires from AC load cable into Switched AC Output terminals, torque to 6 in-lb. Secure cable jacket to chassis with cable tie.
3. Ensure other system wiring is complete before turning on the AC supply and cabinet breakers.

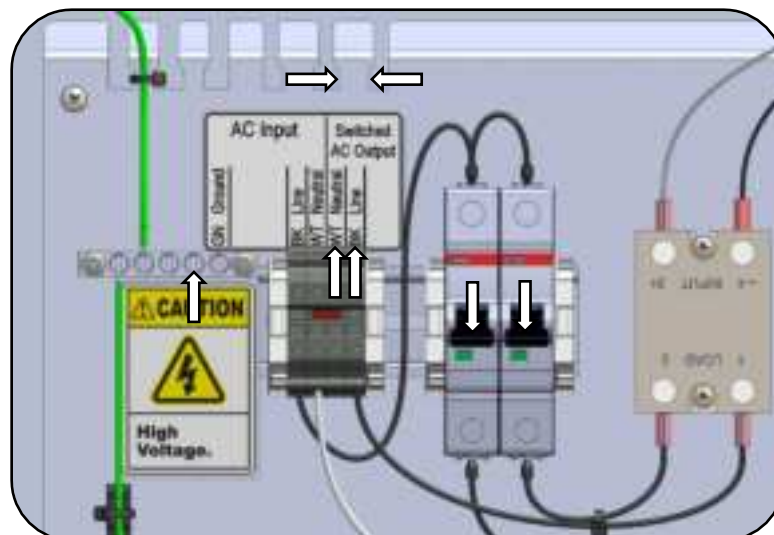

5.7 DC Relay Kit Installation

NOTE

For solar-powered systems it is important to discuss your application with a Carmanah representative to ensure your load will operate sustainably in your location. Shade analysis is highly recommended for understanding how solar access will change according to the time of year. Contact Carmanah for a detailed examination and solar simulations for your site.

The G Series DC Relay Kit option includes a pre-installed DC relay. The relay input is prewired to the OUT2 output of the EMS. The relay DC load side is wired to the bottom two Input/Output terminals (DC- and SWDC+) on the EMS. When the EMS LED output turns on, the digital output on the EMS is enabled and the output terminals of the relay close to operate a DC load.

NOTE

The behavior of the Output is modified by the output setting on the EMS. When set to “nite”, the output will only be enabled when the LED output is on and at nighttime. See [Section 6.1](#) for details.

NOTE

The relay model supplied with the DC Relay Kit is Omron part number G3NA-D210B-DC5-24. Please see Omron’s datasheet for more information.

To install a DC load:

1. Remove solar fuse, and then battery fuse from right side cabinet.
2. Install suitable #6 stud fork spade terminals onto DC load wires (recommended).
3. Install DC negative (-) load terminal into second-from-bottom DC- terminal on EMS, torque to 12 in-lb.
4. Install DC positive (+) load terminal into bottom SWDC+ terminal on EMS, torque to 12 in-lb.
5. Secure DC load cable jacket to chassis with cable tie.
6. Ensure other system wiring is complete before replacing the fuses.

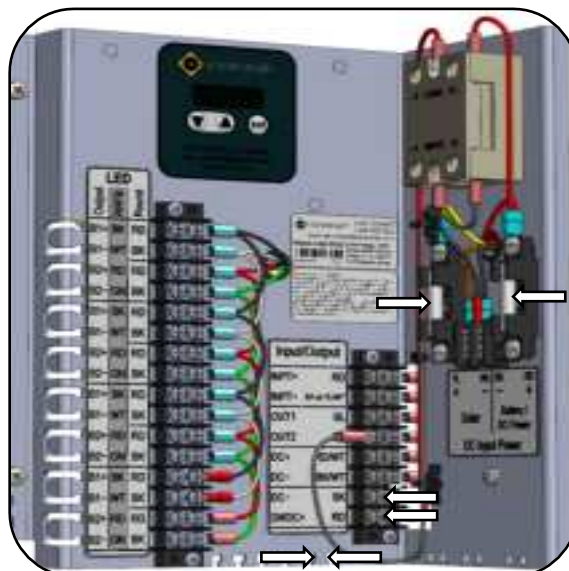

5.8 Polara XAV Controller Kit Installation

The Polara XAV Controller Kit includes the Polara XAV controller prewired to the EMS. The XAV-to-button harness (available in 16ft, 36ft, or 75ft lengths) is also prewired to the controller. Please see Polara’s installation documentation for installation details for the audible push button station.

To access the XAV voice chip module, follow the instructions below:

1. The voice chip module is located beside the top three XAV APS terminals as shown below. It can be removed by gently pulling it out of its connector on the XAV circuit board.
2. To reinstall the voice chip module, ensure the chip IC is oriented on the left, and insert the module through the slot in the XAV chassis so it aligns with the connector on the XAV PCB. Push until fully seated.

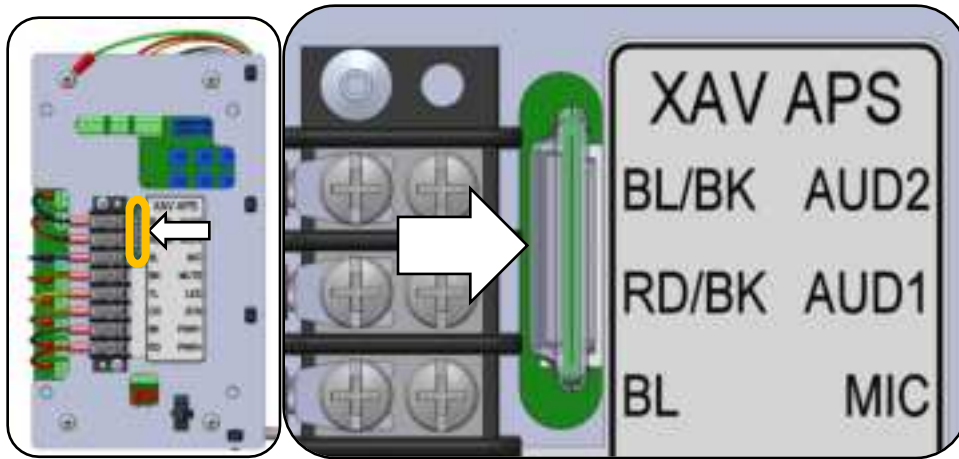

To install the XAV-to-button harness (available in 16ft, 36ft or 75ft lengths), following the instructions below:

1. Match 8 wires from XAV-to-button harness to XAV APS terminals. Torque to 12 in-lb.
2. Secure harness to cable tie mount.

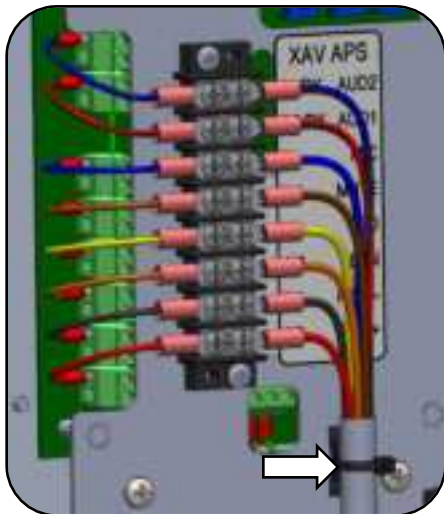

| Wire Colour | Function |
|-------------|----------|
| Blue/Black | AUD 2 |
| Red/Black | AUD 1 |
| Blue | Mic |
| Brown | Mute |
| Yellow | LED |
| Orange | Button |
| Black | DC- |
| Red | DC+ |

5.9 Polara iNX Audible Push Button Kit Installation

The Polara iNX supersedes the XAV audible push button and integrates the controller inside the push button assembly. The iNX push button kit includes a push button harness (available in 16ft, 36ft or 75ft lengths), the iNX audible push button assembly, and the R10-25 pedestrian push button sign.

NOTE The Digital Output on the EMS must be set to ALL when used with the iNX push button on standard systems.

NOTE For systems with no installed fixture, the Digital Output must be set to “nLED.” This function requires the EMS to have firmware version 1.1.5.0 or newer. See [Firmware Version](#) in [Section 6.1](#) for instructions on how to check the EMS firmware version.

1. Connect the iNX harness to the EMS and push button terminals as detailed below. Torque EMS terminal block screws to 12 in-lb. Please consult Polara’s installation documentation for more information.



| iNX Terminal | Wire Color | EMS Terminal | Function |
|---------------------------|------------|--------------|---|
| GND | Black | DC- | Battery Negative |
| PWR | Red | DC+ | Provides +12V power to push button |
| BUTTON (Non-Polarized) | Orange | INPT+ | Triggers EMS to activate beacons |
| | Brown | INPT- | Triggers EMS to activate beacons |
| LIGHTS (Non-Polarized) | Blue/Black | DC- | Battery Negative |
| | Yellow | OUT2 | Provides confirmation signal that beacons are flashing to iNX, triggering audible message |

2. Secure cable to EMS near terminal block using cable tie.
3. Check that the button is configured correctly.

NOTE This can be done via the iNX Android and iOS app, refer to the Polara iNX user manual for details.

Ensure that the “wireless sync” feature is disabled. Go to *Wireless Sync* from the app homepage.

Ensure that the flash pattern in the Polara app corresponds to the beacon flash pattern. The default is set to “rapid flash,” suitable for RRFBs. In the settings menu, under *LED Flash Behavior*, select the *Play Predefined Pattern* option and chose the appropriate option based on the EMS flash pattern:

| EMS Flash pattern | iNX flash pattern |
|--------------------------------------|-------------------|
| rFb, rFb2, 0.1u, 0.25u, 0.1uF, 0.1AF | Rapid Flash |
| 0.5u, 0.5A, 0.5A3 | Simple On/Off |
| stdY | Solid LED On |

5.10 Campbell Guardian Audible Push Button Kit Installation

The Campbell Guardian audible push button kit includes a push button harness (16ft, 36ft, or 75ft) prewired to the G Series EMS (as shown below), along with the Guardian audible push button, and an associated sign. Please consult Campbell's installation documentation for more information.

NOTE

The Digital Output on the EMS must be set to ALL when used with the Guardian push button on standard systems.

NOTE

For systems with no installed fixture, the Digital Output must be set to nLED. This function requires the EMS to have firmware version 1.1.5.0 or newer. See [Firmware Version](#) in [Section 6.1](#) for instructions on how to check the EMS firmware version.

Contact Carmanah for instructions if adding an audible push button to an older system.

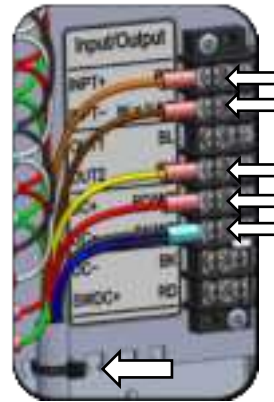
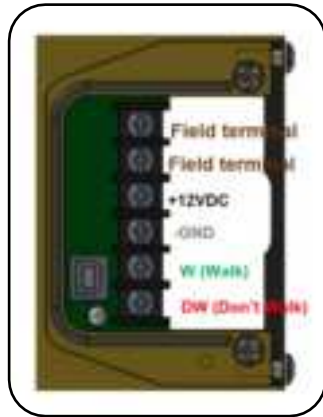

| Campbell Terminal | Wire Color | Terminal Block Connection | Function |
|-------------------|------------|---------------------------|---|
| Field terminal | Orange | INPT+ | 1 of 2 push button inputs to EMS from Guardian |
| Field terminal | Brown | INPT- | 2 of 2 push button inputs to EMS from Guardian |
| +12VDC | Red | DC+ | Positive side of 12-volt power supply for Guardian |
| -GND | Black | DC- | Negative side of 12-volt power supply for Guardian |
| W (Walk) | Yellow | OUT2 | Guardian sense line for triggering recorded message when fixture flashing is detected |
| Not Used | Blue/Black | DC- | Not Used, apply tape to wire end or trim at jacket exit |
| DW (Don't Walk) | | | Not used |



5.11 MS Sedco Passive Detector Installation

Several MS Sedco sensors such as SmartWalk™ TX-S, SmartWalk™ XP-S or TC26-B can be connected to G Series systems to operate the system automatically.

Refer to Carmanah Passive Detection Install and Configuration Guide for more detailed information.



For solar G Series systems, a “-S” model SmartWalk™ sensor must be used. SmartWalk™ “-S” sensor models consume less operating power and are required for sustainable solar system performance. AC-powered G Series systems can use either the standard or “-S” models.



Ensure Fail Safe switch #4 on the SmartWalk™ is set to the OFF position. This conserves power by only energizing its internal relay when a pedestrian is detected.



Push buttons can be used in conjunction with MS Sedco sensors by wiring the push button in parallel to the INPT+ and INPT- EMS terminals.

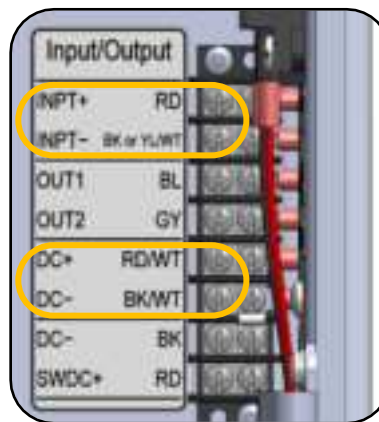

Fail Safe Off wiring (Solar or AC G Series):

| SmartWalk™ Terminal (Fail Safe Off, SW #4 off) | Wire Color | G Series EMS Input/Output Terminal | Function |
|--|------------|------------------------------------|---|
| Pin 1 | Red | DC+ | DC+ power from G Series EMS to SmartWalk™ |
| Pin 2 | Black | DC- | DC- (ground) from G Series EMS to SmartWalk™ |
| Pin 6 | Orange | INPT+ | Relay Normally Open signal from SmartWalk™ to EMS |
| Pin 5 | Green | INPT- | Relay Common signal from SmartWalk™ to EMS |

For more information on installation or configuration, refer to the MS Sedco manual or contact MS Sedco.

6.0 Energy Management System Programming and Testing

The Energy Management System (EMS) has several programming functions and settings. These are accessed through the On-Board User Interface (OBUI). Specific products will use a subset of the complete OBUI settings, which will be covered in this manual's sections specific to each product.



Certain combinations of settings can result in the system not meeting intended specifications (such as ITE or SAE) or cause damage to the equipment. Contact Carmanah for guidance if unfamiliar with system limitations.



Modifying settings can significantly affect the solar energy balance of the system, which could result in reduced battery life and performance. Contact Carmanah for more information about sustainable settings in your location.

6.1 EMS On-Board User Interface Operation

Three buttons on the EMS OBUI are used to navigate and change settings and activate functions as required. The “Up arrow”, “Down arrow”, and “set” button are used to scroll through menus, access and change settings, and accept new settings.

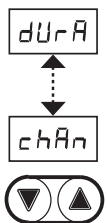
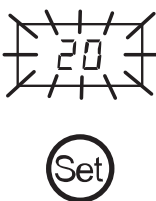
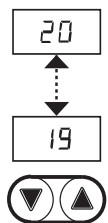
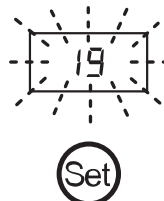

EMS On-Board User Interface (OBUI)

| | | | |
|--|---|--|---|
| <p>Use the Up and Down arrow buttons to scroll through the menu.</p>  | <p>Press and hold the “set” button to edit a setting. The display will blink when the setting is ready to edit.</p>  | <p>Use the Up and Down arrow buttons to adjust the setting when in edit mode.</p>  | <p>Press and hold the “set” button to accept the new setting. The display will flash 3 times to indicate the setting has been accepted.</p>  |
|--|---|--|---|

Using the Up or Down buttons on the OBUI, the following menu items will appear:

| Menu Item | User-adjustable? | Broadcast to other systems?* |
|---------------------------------------|------------------|------------------------------|
| LED Fault | No | No |
| Battery Status | No | No |
| Solar Status | No | No |
| Flash Pattern | Yes | No |
| Input Type | Yes | No |
| Flashing Duration | Yes | Yes |
| Intensity (LED Driver Current) | Yes | No |
| Night Dimming | Yes | Yes |
| Ambient Auto-Adjust | Yes | Yes |
| Automatic Light Control (ALC) | Yes | No |
| LED Temperature | Yes | No |
| Internal Calendar | Yes | No |
| Radio Enable | Yes | No |
| Radio Channel | Yes | No |
| Radio Detection Status | No | No |
| Digital Output | Yes | No |
| Push Button Input Status | No | No |
| LED Fixture Text | Yes | No |
| Built-In Self-Test | Yes | No |
| Firmware Version | No | No |

*No indicates that changing the setting on one system will not broadcast the change to other wireless systems.

LED Fault

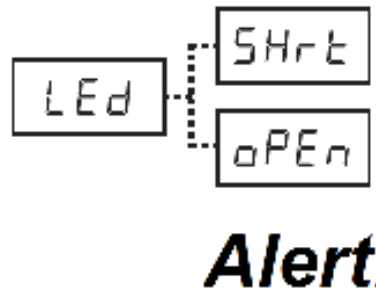

LED: LED beacon fault alert. Only appears if there is a problem with the LED beacon(s)
Use the tEST function to clear the alert

SHrt: LED beacon is shorted

oPEn: LED beacon has an open circuit

The LED Fault message does not normally appear in the OBUI menu, and only appears when the EMS has detected that one or more fixture connections are shorted or disconnected. When the problem has been corrected and flashing is triggered, the LED Fault menu item will disappear.

In addition to fixtures not being connected properly, the EMS may also display the **LED OPEN** fault message when:

NOTE

- a fixture with too high an operating voltage is connected
- a very long LED harness is combined with a high intensity setting
- a single LED sign or beacon is used with an alternating flash pattern

LED Fault alert (exceptions):

NOTE

- will not detect a disconnected fixture when more than one beacon/sign or any number of light bars are installed with a unison flash pattern
- will not detect a disconnected fixture when more than one lightbar or more than two beacons/signs are installed
- may not detect a fixture short circuit or disconnection when a rapid or quick flash pattern is used. Temporarily changing to flash pattern 0.5A can assist in troubleshooting.

Battery Status

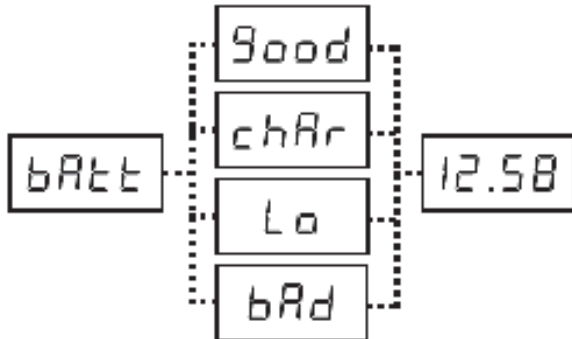
| | | |
|--|-------|--|
|  | Good | bAtt: Battery status and voltage good: Battery is charged (>12.6V) chAr: Battery requires charging (12.6 - 11.7V) Lo: Battery has very low voltage (11.69 - 10.50V) bAd: Battery needs replacing (<10.50V) 12.58: Battery voltage |
| | chAr | |
| | Lo | |
| | bAd | |
| | 12.58 | |

Battery Status reports general battery state as well as actual battery voltage. When the Battery Status reads **chAr** (charge), the voltage is lower than normally desirable, but the system will continue to operate normally. When the Battery Status reads **Lo** (low), the system is in Low Voltage Disconnect (LVD). LVD is a safety mechanism that the EMS invokes to prevent over-discharge of the battery. When in LVD, the fixtures will *not* flash and the digital output signal (if used) is also turned off.

Solar Status

| | | |
|---|-------|---|
|  | nltE | SoLr: Ambient brightness sensor status nltE: Sensor is not detecting light (nighttime) dAY: Sensor is detecting light (daytime) 16.55: Solar panel voltage |
| | dAY | |
| | 16.55 | |

The Solar Status indicates whether the system has determined it is night or day based on the photosensor located in the top of the body near the antenna. The second value that is displayed is the output voltage of the

solar panel and is useful for troubleshooting. Solar panel voltage in sunlight will typically be between 15 and 20 volts.

Flash Pattern

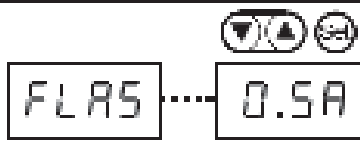

FLAS: Flash pattern

rFb, rFb1, rFb2, 0.1U, 0.25U, 0.5U, 0.5A, 0.5A3, 0.1UF, 0.1AF ...

See latest manual for up-to-date flash pattern descriptions

The EMS can be programmed for 11 different flash patterns.

- rFb Standard FHWA RRFB WW+S (wig-wag plus simultaneous) flash pattern.
- $rFb1$ RRFB flash pattern (WW+S), timing is less accurate than rFb pattern and should only be used to match existing systems that are using rFb1.
- $rFb2$ WSDOT custom pattern for circular rapid flashing beacons.
- $0.5U$ MUTCD-compliant unison flash 0.5 second pulse 60 flashes per minute.
- $0.5A$ MUTCD-compliant alternating flash 0.5 second pulse 60 flashes per minute. Carmanah default.
- $0.5A3$ MUTCD-compliant alternating flash 0.5 second pulse 60 flashes per minute for 3 alternating beacons (2+1).
- $0.1U$ Unison flash 0.1 second pulse 60 flashes per minute.
- $0.25U$ Unison flash 0.25 second pulse 60 flashes per minute.
- $0.1UF$ Unison quick flash. Burst of three 0.1 second pulse flashes. 60 bursts per minute.
- $0.1AF$ Alternating quick flash. Burst of three 0.1 second pulse flashes. 60 bursts per minute.
- $stdY$ steady on (output1 only), multiple LED loads must be connected in series.

The flash pattern is pre-set at the factory based on your requirements and installation location, which are typically discussed at the time of ordering. Should the installation location or situation change, you can adjust this setting. Please contact Carmanah Customer Service prior to making any adjustments.

NOTE

If a single fixture is being used, a unison flash pattern must be selected. If a single fixture is set to an alternating pattern, the EMS will attempt to turn on a second fixture and generate an LED fault when it cannot. The EMS uses a single LED driver that toggles two “banks” on and off. For alternating flashing, fixtures are attached to different banks. An RRFB light bar uses both banks to achieve its mix of alternating and simultaneous flashing.

NOTE

When an odd number of circular beacons is used, a unison flash pattern must be selected to achieve consistent brightness between beacons or the 0.5A3 special pattern.

NOTE

When programming intensity for **RRFBs or ITE-compliant circular beacons**, minimum current settings must be applied (see the Intensity section). Contact Carmanah for guidance.

NOTE

When connecting multiple LED Loads using the stdY flash pattern, loads must be connected in series to avoid thermal runaway. The combined forward voltage of all the loads connected in series must be less than 30V.

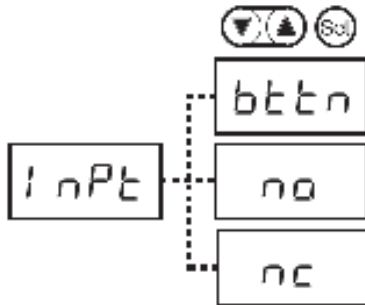
Input Type

InPt: Input type

bttt: Momentary push button

no: Normally open switch

nc: Normally closed switch (24/7)

The Input Type setting determines a key difference between the EMS acting as a pedestrian crosswalk system, a 24/7 flasher, or a school zone flasher. Set Input Type according to the following options:



For RRFBs and crosswalk beacons, only use bttt for the input type; all other options are non-compliant and not to be used.

| | |
|-------------|---|
| bttt | “Push Button”. Used for pedestrian crosswalks (R920, R820). A push button is wired to the push button input terminals of the EMS, and when the button is pushed, a momentary short-circuit across the input terminals occurs, causing the fixtures to flash for the duration set in the “Duration” setting. Carmanah default. |
| no | “Normally Open”. Used for School Zone Flashers (R829) or any application where the flashers must activate on demand. The usual state of the push button input terminals is to be open and not have a short-circuit across them. While the terminals are open, fixtures do not flash. If a short-circuit is applied across the terminals - provided by a time switch, override switch, or some other device - the fixtures will begin to flash and will continue to flash for as long as the short-circuit is applied. |
| nc | “Normally Closed”. Used for 24/7 flashers (R247). The flashers will flash continuously, day and night, unless a short-circuit is applied to the push button input terminals. The override switch can be used to turn the beacons off by short-circuiting the button input terminals. |



If radio-enabled systems configured with different input types are within communication range of one another, radio channel settings should be set appropriately to avoid unintended operation. See Radio Channel section.

Flashing Duration

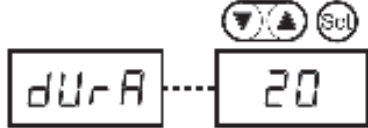

dUrA: Duration of the flashing
20: Duration in seconds from 5 to 3600

Flashing Duration is used for pedestrian crosswalks and sets the amount of time the fixtures will flash before extinguishing. The available settings are:

- 5 to 60 seconds in 1 second steps
- 60 to 1200 seconds (20 minutes) in 60 second steps
- 3600 seconds (one hour)

The Carmanah default duration is 20 seconds. Longer duration flash periods are useful for applications such as warning traffic of heavy equipment on logging and mining haul roads.

NOTE

Extending the Flashing Duration setting significantly can affect the solar energy balance of the system. Contact Carmanah to for more information about sustainable settings in your location.

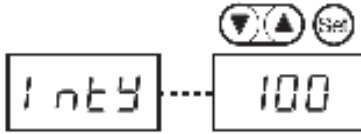
Intensity (LED Driver Current)

IntY: Output current

100: Output in mA, from 20 to 1400

The value shown in the user interface is the total current being provided to the fixtures. This current is divided among the fixtures, depending on how many fixtures are connected and whether they are flashing in unison or alternating.

When RRFB flash patterns (rFb , rFb1 or rFb2) are used, the programmed Intensity value is the total current during the simultaneous portion of the flash pattern, when both left and right modules of a light bar (or both circular beacons) are on simultaneously. During portions of the RRFB flash pattern when only one module or beacon is illuminated, the EMS automatically reduces the current to half the programmed value because it knows that the current will be flowing through one module/fixture.

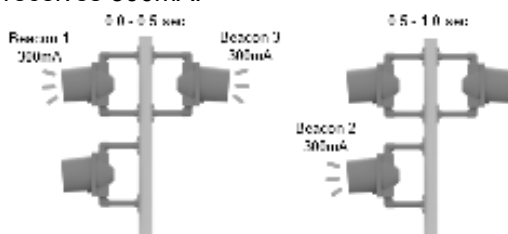
The following table provides some examples of EMS intensity settings and the fixture currents that result with different flash pattern types:

| Fixtures | Flash Pattern | EMS Intensity Setting | Resulting Fixture Current (per fixture) |
|--------------------------------|-------------------|-----------------------|--|
| Two Circular Beacons | Alternating | 340mA | 340mA |
| Two Circular Beacons | Unison | 340mA | 170mA |
| Two Circular Beacons | Unison | 400mA | 200mA |
| Two Circular Beacons in series | Steady on stdY | 300mA | Both beacons are connected in series to output1 ("LED B1") and receive 300mA. |
| Three Circular Beacons | Alternating 0.5A3 | 600mA | <p>For the first 0.5s of the flash pattern, beacons 1 and 3 connected to output1 ("LED B1") each receive 300mA. During the second half of the pattern, beacon 2 connected to output2 ("LED B2") receives 300mA.</p>  |
| One Light Bar | rFb | 160mA | <p>During the simultaneous portion of the flash pattern, 160mA is provided to the light bar and is split equally between the left and right modules, resulting in 80mA per module.</p> <p>During the wig-wag portion of the pattern, the EMS automatically reduces the current by half to 80mA, which flows through one side of the light bar or the other side.</p> |

| | | | |
|----------------|-----|-------|--|
| Two Light Bars | rFb | 320mA | <p>During the simultaneous portion of the flash pattern, 320mA is split equally between the two light bars, and again between left and right modules in each light bar, resulting in 80mA per module.</p> <p>During the wig-wag portion of the pattern, the EMS automatically reduces the current to one half (160mA) which flows through one side of both light bars or the other side of both light bars. The current splits equally between the light bars, so each module receives 80mA.</p> |
|----------------|-----|-------|--|

To avoid damaging LED-enhanced signs, do not exceed the following maximum intensity settings based on the fixture configuration and flash pattern:

| Maximum Intensity Setting (mA) for LED-Enhanced Signs | | | |
|--|-----------------------|----------------------|----------|
| Flash Pattern and Fixture layout | | Yellow or White LEDs | Red LEDs |
| Steady-on | Single or Series | 260 | 340 |
| 0.5s on 0.5s off | Single or Alternating | 520 | 700 |
| | Dual Unison | 1040 | 1400 |
| 0.1s on 0.9s off | Single | 1040 | 1040 |
| | Dual Unison | 1400 | 1400 |

NOTE

These maximum settings will result in very bright signs and should not normally be required.

The intensity is pre-set at the factory based on your requirements and installation location, which are typically discussed at the time of ordering. Should the installation location or situation change, you can adjust this setting. Please contact Carmanah Customer Service prior to making any adjustments.

Intensity adjustments are 20mA per step.

NOTE

The maximum output current of the LED driver is 1400mA.

NOTE

The minimum output current of the LED driver is 40mA. AAA, ALC and Night Dimming features will not reduce the LED current further.

NOTE

As mentioned in Flash Pattern in this Section, odd numbers of round beacons must be set to a unison or the 05A3 flash pattern to ensure all LEDs are powered equally.

NOTE

When programming intensity for **RRFBs or ITE-compliant circular beacons**, minimum current settings must be applied. Contact Carmanah for guidance.

Night Dimming



nite: Nighttime dimming
30: Percentage of daytime level, from 10 to 100%

Night Dimming sets the night intensity as a percentage of the programmed Intensity setting. It is set in 10% steps. For no night dimming (equal to 100% of daytime level), this is set to off.



If using night dimming and your system must meet intensity compliance such as ITE or RRFBs J595, ensure that a worst-case night dimming does not dim the fixtures below the required current needed to achieve compliance. Contact Carmanah for guidance.

Carmanah Night Dimming default is 30% for all fixtures except red beacons which are not dimmed at night per FHWA 4(09)-28 (I).

Ambient Auto-Adjust

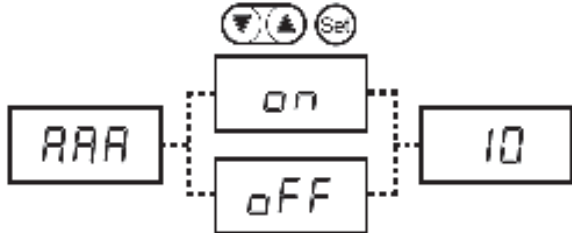

AAA: Ambient auto-adjust
on: Ambient auto-adjust is enabled
off: Ambient auto-adjust is disabled
10: Ambient auto-adjust dim level

AAA automatically adjusts fixture intensity between 50% and 100% of the programmed Intensity setting depending on ambient brightness. This reduces brightness on overcast days to prevent glare. AAA can be set either on or off. When AAA is on, it reports a value from 1 to 10 corresponding to the instantaneous ambient light level measured by the EMS photosensor. A reading of 1 means ambient light levels are ~1,000 lux and the daytime intensity is currently being dimmed to 50%. A reading of 10 means ambient light levels are at least 27,000 lux and 100% daytime intensity is being applied.

With AAA on, the dim level value (1 – 10) is displayed in real time, so it is a good feature to use for troubleshooting the photosensor operation. A flashlight can be used to shine bright light into the photosensor and invoke a “10” value.



If using AAA for circular beacons, and if ITE compliance is required, ensure that a minimum value of 50% does not dim the beacons below the level required for compliant operation. For RRFB applications, ensure that a minimum value of 50% does not dim the fixtures below the mandatory SAE J595 specification as per the FHWA. Please contact Carmanah for additional information.



With AAA off, the ambient auto-adjust dim level value reported (1 – 10) is not updated. The value reported corresponds to the ambient brightness detected when the feature was last on.

Carmanah Ambient Auto Adjust default is on.

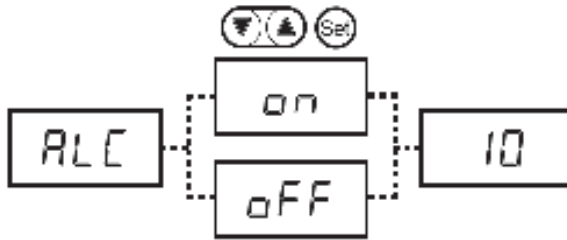
Automatic Light Control (ALC)

ALC: Automatic light control

on: Automatic light control is on

off: Automatic light control is off

10: Automatic light control level

Automatic Light Control (ALC) is a Carmanah patented energy management system. ALC allows the EMS to reduce the fixture brightness in response to low battery states of charge. ALC activates if battery charge gets below 70%, which does not occur in normal circumstances when the system is properly sized for its location.

When ALC is set to on, the UI will report the amount of ALC being applied as a percentage. A reading of 70% means that ALC is reducing the fixture current to 70% of its normal value. If battery voltage continues to decrease, the ALC value will also decrease until LVD (Low Voltage Disconnect) is eventually reached.

Carmanah default is on.

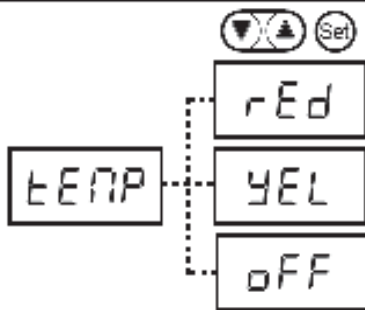
LED Temperature

tEMP: Temperature correction of beacon

rEd: Red beacon

YEL: Yellow beacon

off: Off used for light bar

LED Temperature is set according to the color of the LED in the fixture. The EMS uses this information to apply fine adjustments to the fixture current to account for changes in LED efficacy with changing ambient temperature, ensuring consistent brightness regardless of ambient temperature.



Although the light bars contain yellow LEDs, LED Temperature should be off for systems using light bars.

The LED Temperature setting is correctly pre-configured in the factory.

Internal Calendar

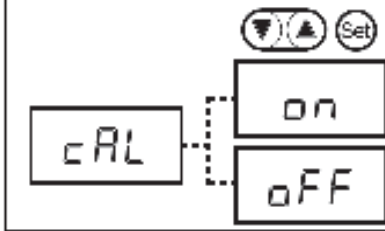

cAL: Internal calendar
on: Calendar is enabled
off: Calendar is disabled

If a system is equipped with the optional internal calendar module, it will be provided with a USB cable that allows users to program the calendar to schedule when the fixtures flash. When the calendar is enabled, the fixtures will flash according to the schedule programmed in the calendar. The calendar accounts for Daylight Savings Time (DST) and leap years and has a maximum schedule length of 512 days. The software to communicate with the R829 calendar system is available from Carmanah.

Where a group of radio-equipped R829s are used, enabling the calendar on one R829 will make it a “Master” system in the group. The other R829 “Slave” systems should have their calendars turned off, and they will flash only whenever the Master system broadcasts on or off signals as it turns on and off itself.



Even if the calendar is disabled, a calendar can still be programmed into the EMS using the USB cable, but the R829 will not follow the programmed schedule until the calendar is enabled.



To program the internal calendar using a PC with the School Zone Calendar Configuration software, the software version must be 1.2.0 or higher.



See separate calendar programming guide for comprehensive programming and operation of the internal calendar feature.

Carmanah Internal Calendar default is on for systems equipped with the optional internal calendar module, and off for systems without it.

Screenshot of Carmanah School Zone Calendar Configuration software:

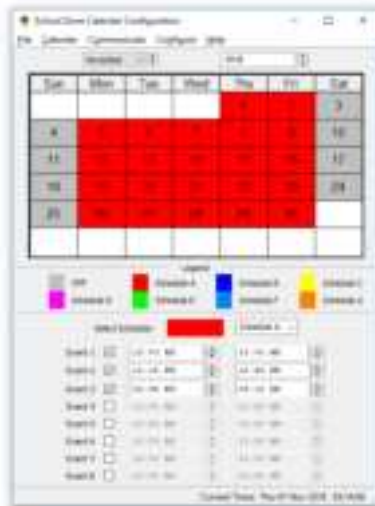

Radio Enable

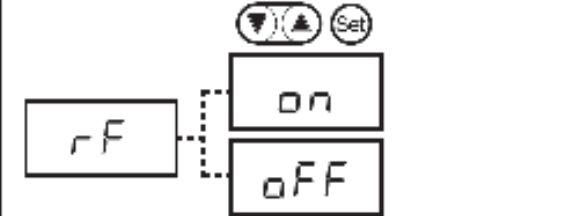
| | |
|---|--|
|  | rF: Radio on: Radio is enabled oFF: Radio is disabled |
|---|--|

Radio Enable is used to turn the radio module on or off. This feature can be used for troubleshooting. The EMS will automatically disable the radio if Low Voltage Disconnect activates. A system without a radio will still show the Radio Enable entry, but it will not have any effect on behavior.

Carmanah Radio Enable default is on for systems containing the radio module, and off for systems without it.

Radio Channel

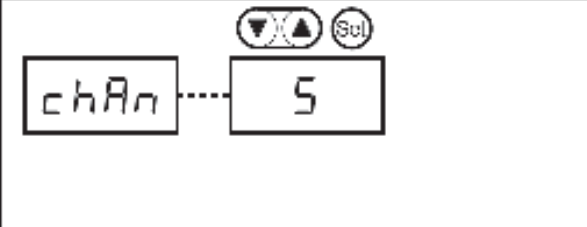
| | |
|---|---|
|  | chAn: Radio channel for synchronized systems 5: Selected channel from 1 to 14 (default is 5) |
|---|---|

For radio-equipped systems, the Radio Channel setting is used to configure the channel that is used for communication with other systems in the same group. Groups near to each other will have their channels set to different values to ensure there is no accidental cross-activation between them. Changing the channel is a useful troubleshooting step if some systems are experiencing intermittent issues. The 2.4GHz band that the EMS radio module uses is public spectrum; reception problems can be the result of nearby interference from other sources.

NOTE Channel changes are not broadcast to adjacent systems.

NOTE Systems without radios will still show a channel assignment, but it will not have any effect on behavior.

Carmanah default Radio Channel is 5.

Radio Detection Status

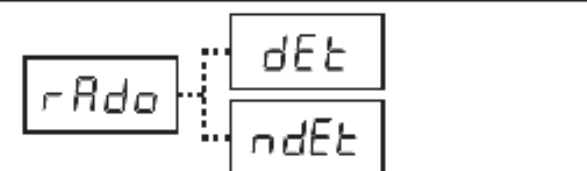
| | |
|---|--|
|  | rAdo: Radio detection status dEt: Radio is detected ndEt: Radio is not detected |
|---|--|

Radio Detection Status indicates whether the EMS has detected a radio module. Radio Detection involves more than sensing the physical presence of the radio; the EMS interacts with the radio and tests several things before declaring the radio “detected”.

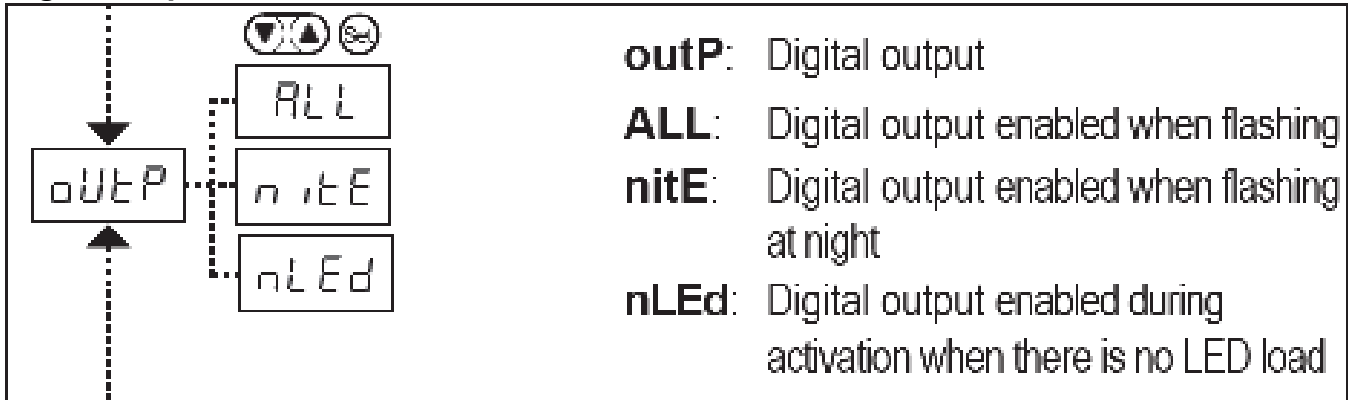
Digital Output

The Digital Output feature of the EMS provides a steady 12-volt output signal at the OUT2 terminal (see diagram in [Section 3.5](#)) whenever the system fixtures are activated and no faults are detected. This is a useful feature for signaling the flashing state to other equipment such as overhead lighting. When set to all, Digital Output will provide a steady 12-volt output signal whenever the fixtures are flashing day or night. When set to nite, the 12-volt output signal will appear only when the fixtures are flashing at night (as determined by the photosensor). When set to nLED, the fixture fault detection is bypassed so that the 12-volt output signal will appear even if no LED fixture is installed. The 12-volt signal is intended to control external relays only. The voltage available at the OUT2 terminal decreases with increasing terminal current (see note below).

Contact Carmanah Customer Service for support on how to use the Digital Output feature. The Digital Output feature is pre-wired during the factory assembly and is not intended to be wired by end users after purchase.

Carmanah Digital Output default is “all”. Please refer to the EMS settings in this manual or on the door label inside the cabinet.



OUT2 is intended as a control signal only and can be characterized by the following description and formula.

The voltage available at the OUT2 terminal changes depending on the current flowing through OUT2. The voltage available at OUT2 can be approximated by the formula:

$$V_{OUT2} = V_{in} - (I_{OUT2} \times 470) - 1.4$$

Where:

V_{OUT2} is the voltage at the OUT2 terminal in Volts,
 V_{in} is the input voltage present at the battery/DC Power terminal in Volts (see below), and
 I_{OUT2} is the current drawn by the load connected to OUT2 (in Amperes)

For proper load operation, ensure there is sufficient voltage available at the OUT2 terminal to operate the load at its rated current when battery voltage is 11.7V (the LVD threshold). It is recommended that you contact Carmanah for assistance with custom I/O applications.

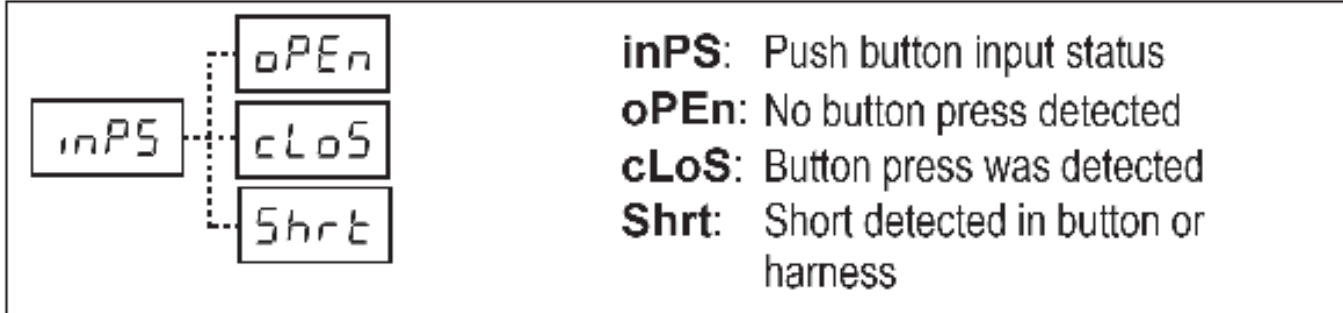
Push Button Input Status

Push Button Input Status reports different states depending on the product configuration.

Pedestrian Crosswalk: Input Status will normally read **oPEn**. During the time that the push button is held down, Input Status will report **cLoS** (for closed). If the push button is held down or shorted for at least 20 seconds, Input Status will show **Shrt** (for short-circuit).

School Zone Flasher: Input Status will read **oPEn** whenever the internal calendar or the attached time switch is not activating the fixtures. When the fixtures are flashing due to activation of either of these two sources, Input Status will read **cLoS**.

24-Hour Flasher: Input Status will normally read **cLoS**. Although there is no physical wire across the input terminals, the system considers the terminals to be connected to invoke constant flashing. If a short is applied to the input, 24-hour flashing will cease, and the Input Status will change to **oPEn**.

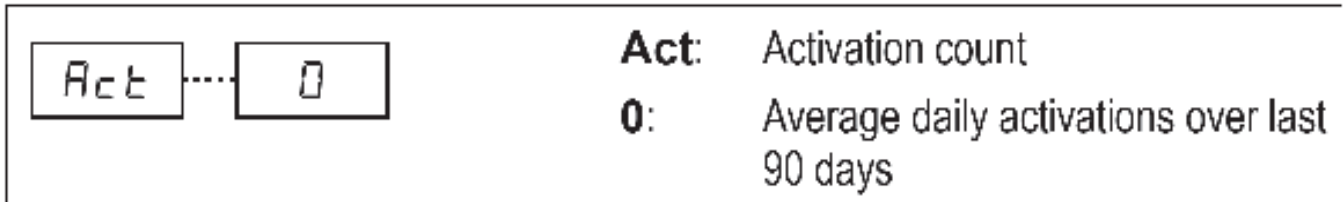
Activation Count

Activation Count keeps track of the average number of daily pedestrian push button activations over a 90-day window. Activation Count is stored in volatile RAM memory and is erased if power is removed. If it has been fewer than 90 days since the last bootup, Activation Count is averaged over the number of days since bootup. For this feature, the EMS considers a “day” as 24 hours passing, rather than using day/night transitions detected by the photosensor.

LED Fixture Test

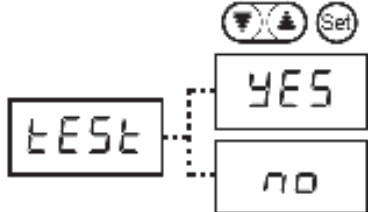
| | |
|---|--|
|  | <p>tEst: Test the system and clear any fault warnings</p> <p>YES: Activates the LED beacon</p> <p>no: Skips the test, does not clear any warnings</p> |
|---|--|

The LED Fixture Test function causes the fixture(s) to flash independently of an activation input from a physical push button, time switch, internal calendar or external control. The test will activate the fixture for 5 seconds. “Test” is a good way to determine whether a problem is caused by the fixtures.

Installers can do this from the EMS without having to climb down to the push button or override box to test.

Built-In Self-Test (BIST)

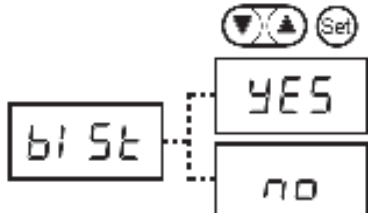
| | |
|--|---|
|  | <p>bISt: Built in system test</p> <p>YES: Activates the built-in system test</p> <p>no: Skips the built-in system test</p> |
|--|---|

The Built-In Self-Test (BIST) runs a self-test on the system. BIST results are used for troubleshooting the system. After the BIST has been started by selecting “Yes”, the display will flash ٤٤٤٤ for the duration of the test and will then display hexadecimal information that can represent one or more issues. The BIST can be used for troubleshooting remotely with Carmanah Customer Service.

Refer to [Section 9.1](#) for BIST Error Code hexadecimal interpretation table.

NOTE

The BIST may report an ambient brightness sensor error (0080) because it is expecting a bright light that tests the sensor during manufacturing. Shining a flashlight on the ambient brightness sensor during the test or running the BIST on a sunny day should result in no error being generated.

NOTE

The BIST will report a charger error (4000) if performed at night or on AC powered systems.

NOTE

The BIST checks that temperature is between 15° C and 35° C. With installation sites frequently having temperatures outside of this range, a temperature check code (0002) will often be generated while there is no real issue with temperature.

Firmware Version



vEr: Firmware version number
0.0.0.0: The firmware version number

The Firmware Version menu item provides the current version of firmware in the EMS.



Firmware cannot be updated in the field.

6.2 SC315-G Programming

To configure the EMS as an SC315:

- ✓ Set **FLAS** (Flash Pattern) to **RFb** (for RRFB)
- ✓ Set **inPt** (Input Type) to **bEtE**
- ✓ Set **durF** (Flashing Duration) as desired
- ✓ Set **LEnP** (LED temperature) to **FFF**
- ✓ Set **cal** (Internal Calendar) to **FFF**
- ✓ Set **rF** (Radio Enable) to **on**

6.3 R820-G Programming

To configure the EMS as an R820:

- ✓ Set **FLAS** (Flash Pattern) as desired
- ✓ Set **inPt** (Input Type) to **bEtE**
- ✓ Set **durF** (Flashing Duration) as desired
- ✓ Set **LEnP** (LED temperature) to either **red** or **yel** to match the circular beacon color
- ✓ Set **cal** (Internal Calendar) to **FFF**
- ✓ Set **rF** (Radio Enable) to **on**

6.4 R829-G Programming

To configure the EMS as an R829:

- ✓ Set `FLASH` (Flash Pattern) as desired
- ✓ Set `INPUT` (Input Type) to `NO` (normally open)
- ✓ Set `TEMP` (LED temperature) to either `RED` or `BLUE` to match the circular beacon color
- ✓ Set `CAL` to `ON` unless it is a Slave in a group of wireless R829s, in which case set `CAL` to `OFF`
- ✓ Set `RF` (Radio Enable) to `ON` if the system is in a group of wireless R829s. Otherwise, set `RF` to `OFF`

6.5 R247-G Programming

To configure the EMS as an R247:

- ✓ Set `FLASH` (Flash Pattern) as desired
- ✓ Set `INPUT` (Input Type) to `NC` (normally closed)
- ✓ Set `TEMP` (LED temperature) to either `RED` or `BLUE` to match the circular beacon color
- ✓ Set `CAL` (Internal Calendar) to `OFF`
- ✓ Set `RF` (Radio Enable) to `OFF`

7.0 Commissioning Checklist

After installing and programming the system, the following commissioning verification checklist helps ensure that everything is working as it should be and that your flashing beacon is ready to serve the public for many years of reliable and sustained operation.

- All settings are correct, particularly the LED driver current (“Intensity” in EMS user interface), flash pattern and flash duration (if applicable).
- No LED fault message on the EMS.
- For single or triple fixture systems, ensure the flash pattern is set for unison, 0.5A3, or stdy.
- Fixtures flash properly.
- Press push button, use “TEST” at the EMS user interface at EMS, or activate override switch.
- Light fixtures are tightened and pointed in the correct direction toward oncoming traffic lanes.
- Retrieved calendar from R829-G and computer time used to set clock were accurate.
- Solar panel pointed south (or wherever custom instructions required).
- Override box (if equipped) correctly activates or deactivates the flashing (depending on product configuration).
- The solar panel mounts are secure, and the panel and mount assembly is unable to move or rotate out of position.
- No debris covering the photosensor window on top of the solar engine.
- Vents are clear, and screens are intact.
- Sealing gaskets on door are intact.
- Solar panel is producing voltage in sunlight (use EMS “Solar” menu item).
- System has clear sky access, and no removal of obstructions is required.
- Note the possibility for nearby foliage to eventually shade the solar panel. If so, set a reminder to inspect later.
- Battery voltage is healthy (use either a voltmeter or EMS “Battery” menu item).
- Verify fuses are intact (use voltmeter to confirm fuse continuity).
- RRFB light bar flashing starts with left module first.
- Remote systems are turning on and off correctly via wireless control.
- Verify the indicator LEDs on the ends of light bars can be seen by pedestrians across the street.

8.0 Maintenance and Product Care

The G Series solar engines are designed to operate reliably for years with virtually no need for maintenance. Carmanah recommends routine inspections of the solar panels to ensure that they are unobstructed by anything that may prevent effective solar charging, including:

- Dirt and dust
- Snow
- Leaves
- Debris
- Shade that may have developed after installation due to adjacent plant growth.

The frequency of the inspections depends on location and local weather patterns. A yearly visual inspection of the solar engine is typically sufficient. The system is designed to be maintenance free, but maximum system performance is achieved when the LED lenses and solar panels are clean. When inspecting the interior, ensure that the vent screens are undamaged and that the vents are clear and allow airflow.



Ensure cabinet door is fully closed and latched otherwise damage may occur.



The cabinet can be ordered with an optional padlockable latch for extra security.

8.1 Fuse Replacement

To replace the fuses:

1. Remove any metal jewelry and keep any tools or other conductive objects away from the exposed fuses or battery terminals.
2. Check all wiring for any faults that may have caused a fuse to blow.
3. Identify the battery and solar fuses on the right side of the cabinet. Carefully pry out the solar fuse first, then the battery fuse.

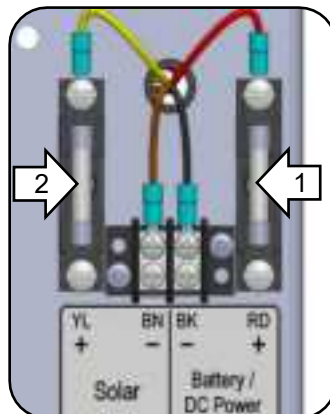

4. Replace a blown fuse with an identical 3AB (1/4" x 1-1/4") fast-acting 15A fuse, Littelfuse part number 0314015.MXP (or equivalent).
5. Install the battery fuse first, then the solar fuse.

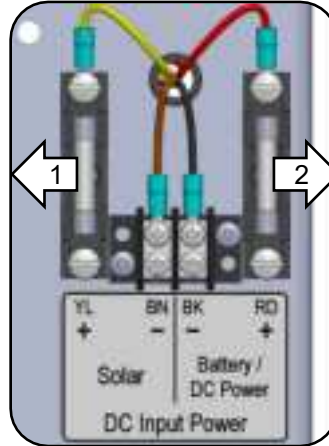

8.2 Battery Replacement



Battery replacements should not be carried out in windy conditions. In all cases, the area at the base of the post must be roped off to prevent people from being injured or killed by falling batteries.

When the system's battery requires replacement, it is recommended that the original manufacturer and model of battery be used.

The general health of the battery is tracked by the system in a form of "odometer." If battery status is reported as **bad**, this odometer function has determined the battery health is too poor to operate reliably and the batteries should be replaced. Battery health is evaluated by considering such things as the total number of charge and discharge cycles and the amount of time spent in a low state of charge.

The health odometer is reset by powering up the system **while the set button is pressed** using the following procedure:

1. Remove the solar fuse and then the battery fuse and install the new battery.
2. Press and hold down EMS "set" button.
3. While continuing to hold down "set" button, reinstall the battery fuse.
4. While continuing to hold down "set" button, wait for **0000** (zero) to appear.
5. Release the "set" button.
6. Reinstall the solar fuse.

The battery health odometer the system is now reset (i.e. it knows that new, healthy batteries have been installed). The battery status should read **good** if the new batteries are 12.6V or higher, or **charge** if they are between 11.7 and 12.6 volts.

8.3 EMS Replacement



The solar panel may still be producing energy if it is exposed to light. Remove the solar fuse and then the battery fuse prior to replacing the EMS.

Sensitive electronics can be damaged by electrostatic discharge. Observe proper ESD precautions when installing the new EMS.

1. Disconnect the solar fuse, and then the battery fuse.
2. Remove the four screws securing the metal EMS chassis to the cabinet.
3. Turn the metal housing over to reveal the circuit board and review the wire positions on the existing EMS. Carefully remove the radio module attached to the antenna from the board if present.
4. Remove the wires from each terminal block connector: with a small screwdriver, press down firmly on the wire release button above the wire and pull the wire out. Photograph the existing wire terminations before starting if convenient.
5. Remove the 4 screws securing the old EMS PCB to the metal chassis and set the old EMS PCB aside.
6. Remove the new EMS PCB from its antistatic bag and secure it to the metal housing with the same 4 screws.
7. Check that the wire strands are straight and that all the strands will go into each terminal. This will avoid short circuits created by stray strands. Twist the wire strands as necessary to keep the strands together.
8. With a small screwdriver, press down firmly on the wire release button and insert each wire into its terminal, referring to the picture taken in step 3.
9. If a radio module is present, carefully thread the antenna connector to the module. Do not damage the circuit board with tools.
10. Secure the EMS enclosure into the cabinet with the screws.
11. Reinstall the battery fuse, then the solar fuse.
12. The system should now be operating and the front display on the EMS should light up.
13. The replacement EMS should be pre-programmed from the factory for your location and installation requirements. You may review the settings if necessary. See the information decal on the back of the solar panel and the user manual for additional information.

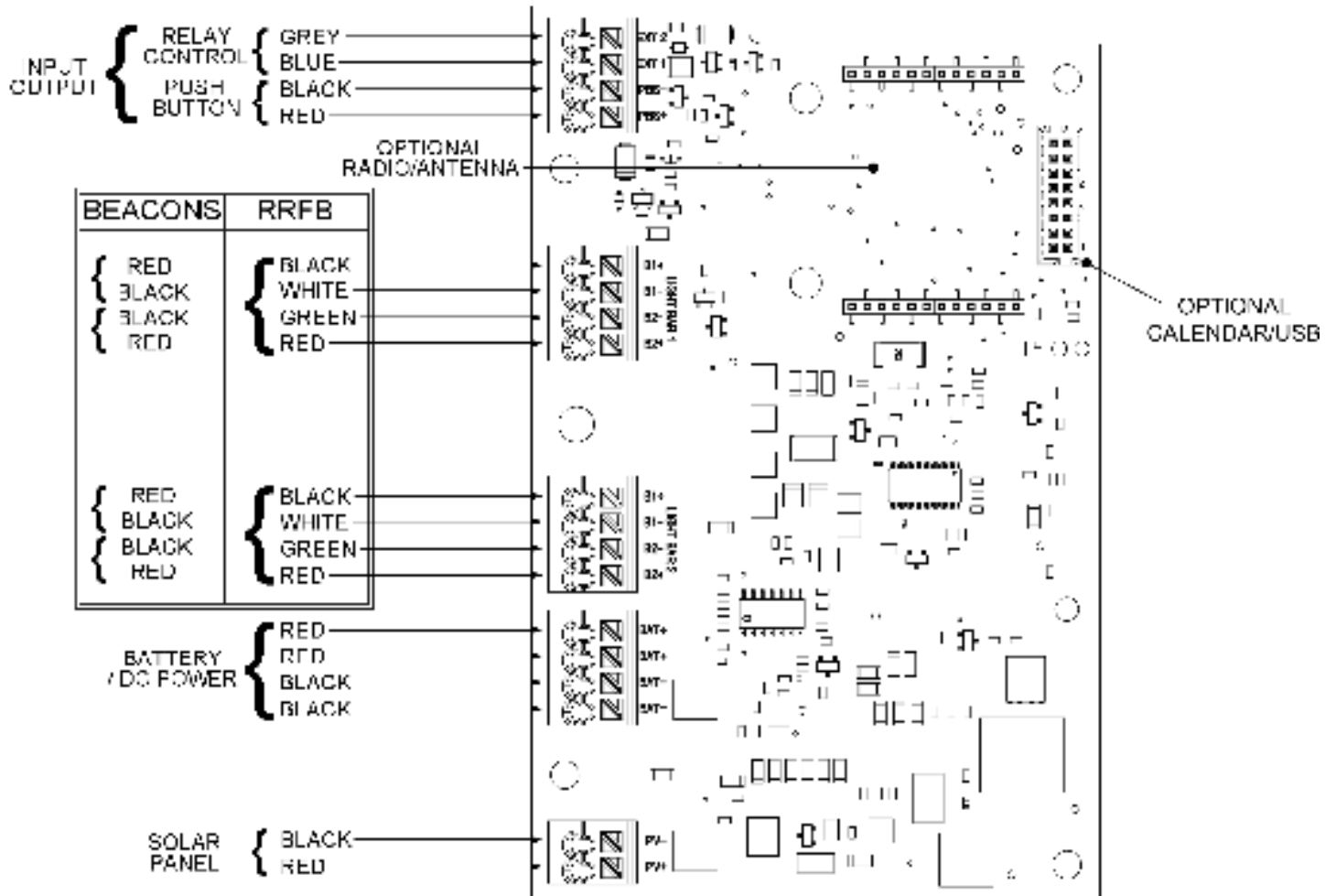

EMS PCBA - Connections Overview

8.4 EMS Recycling

Production of the EMS required the extraction and use of natural resources. The EMS may contain substances that could be harmful to the environment or human health if improperly handled at the product's end of life. To avoid release of such substances into the environment and to reduce the use of natural resources, we encourage you to recycle the EMS in an appropriate way that will ensure most of the materials are reused or recycled appropriately. Contact local recyclers for more information.

9.0 Troubleshooting

| Symptom | Possible Cause and What to Check |
|--|---|
| <p>The EMS does not activate or display any information.</p> | <p>This is typically caused by low or no voltage from the batteries.</p> <p>Check both battery fuses. See Section 8.1 of this manual for fuse information.</p> <p>Using a voltmeter, measure the battery voltage. Battery voltage should be a minimum of 12 volts, with 12.6 volts being nominal normal voltage. If the voltage is very low, charge or replace the batteries and monitor the system for proper operation. Ensure that the solar panel is clean, clear of debris, and is not shaded by buildings or vegetation. If the solar panel is covered or shaded, this will prevent proper battery charging. Once the batteries have proper voltage, check the EMS by running the BIST test and lookup the error codes in the Section 9.1 of this manual.</p> |
| <p>LEDs won't flash when push button on the same post is pressed.</p> | <p>This can be caused by either button failure, a wiring issue, low battery voltage, or the unlikely event of an EMS failure.</p> <p>Check that the button is functioning, and it is providing the typical feedback. If the button has an LED or audio feedback, ensure that these are working. Check the wiring to the button for continuity and make sure the wires are not pinched anywhere along their length.</p> <p>Check the wiring to the LED fixtures for continuity and make sure the wires are not pinched anywhere along their length.</p> <p>Check that the wiring pattern (polarity) is correct on the LED fixtures.</p> <p>Check the battery voltage, either through the OBUI or with a voltmeter (see item above).</p> <p>Test the system using the "Test" function. If the LEDs flash using the OBUI functions, then the problem is in the button or wiring to the button.</p> |
| <p>LEDs on same post flash, but other systems in the wireless group won't flash.</p> | <p>If one system is activated, but the other systems in the group are not turning on, this points to a radio issue.</p> <p>Ensure that all the units are set to the same radio channel using the OBUI. See Radio Channel in Section 6.1 of this manual.</p> <p>Ensure that the units are not too far apart. The maximum distance for proper radio communication is 1,000 unobstructed feet (305m), but real-world effects and signal path can limit range to less than half that value. There can be no barriers or obstructions between systems, such as buildings or billboards.</p> <p>To increase the reliability of radio communications, the different units should be located and oriented so that there is direct line-of-sight between the antennas and so that structures or sources of interference (large</p> |

| | |
|--|--|
| | signs, overpasses, powerlines, etc...) are as far away from the communication path as practical |
| One LED fixture flashes, but other fixtures on the same post does not flash. | This is likely caused by improper wiring of the fixtures. Ensure that the wire colors and polarities match the instructions in this manual. Check that the electrical connections are secure. |
| The LEDs are dim when flashing. | <p>The battery voltage may be too low for proper operation and the system has activated Automatic Light Control (ALC). Check the OBUI for ALC status and battery voltage.</p> <p>Ensure that the solar panel is clean, clear of debris, and is not shaded by buildings or vegetation. If the solar panel is covered or shaded, this will prevent proper battery charging and drive the system into ALC.</p> <p>Check for debris covering the ambient light sensor on top of the solar engine and confirm the photosensor is correctly detecting day and night. A flashlight can be shone into the photosensor to simulate day, and the photosensor can be covered to simulate night.</p> <p>Confirm the intensity is set correctly to a value that has been confirmed to be sustainable using a solar simulation.</p> <p>Check the Ambient light Auto-Adjust (AAA) setting on the OBUI. Turn off the AAA to see if this corrects the dim LEDs.</p> |
| The LEDs appear too bright when flashing | Settings on the EMS can affect the apparent brightness of the LEDs. The intensity setting on the user interface can be turned down to a more suitable brightness level. Verify all fixtures are working. If a fixture stops working, the current that would normally flow through it is redirected into the remaining fixtures, which increases their brightness. |
| Fixtures flash when no button is pressed | <p>This is likely caused by another nearby system on the same radio channel activating the system.</p> <p>Ensure that all units in a group are set to the correct radio channel using the OBUI while also ensuring that nearby systems at a different location are using a different channel.</p> |
| LED Open Fault is showing on User Interface | This is likely caused by using a single fixture with an alternating flash pattern. The EMS is looking for the other fixture in the alternate pattern and declares an "LED Open" fault when it doesn't find one. Set flash pattern to unison. |

9.1 BIST Error Codes

The BIST (Built-In Self-Test) is a useful feature of the EMS for troubleshooting. After the BIST has finished, a code will be displayed on the user interface, which will correspond with one or more results.



If the BIST is run in a low-light environment, it will generate a 0080 error. This does not indicate an issue with the ambient brightness sensor. Shine a flashlight on the window above the EMS to avoid this error.

The hexadecimal number that will be displayed after the BIST test is created by adding together the individual error codes. For example, if there were a charger problem (4000) and a problem with the fixture LED (8000), the hexadecimal sum would be C000. $4 + 8 = 12$, which is "C" in hexadecimal.

The BIST codes can be used to assist Carmanah technical support in solving product configuration or performance issues. Please contact Carmanah technical support if the issue you encounter is not easily solved by reviewing the information provided in this document.

| Code | Error |
|------|---|
| 0002 | Temperature check. Checks that temperature is between 15°C and 35°C. With installation sites frequently having temperatures outside of this range, code 0002 will often be generated while there is no real issue with temperature. |
| 0008 | Battery check. Checks that battery voltage is between 11.7V and 17.268V (max charge voltage at -40°C). Nominal is 12.6 volts when unloaded and not charging. |
| 0010 | Checks that V supply on EMS control board is between 3.2V and 3.4V. Nominal is 3.3 volts. |
| 0020 | Keypad check. Checks all push buttons on user interface (up, down and enter). |
| 0080 | Ambient Brightness Sensor (ABS) check. Checks that the current lux measured by the ABS is above the minimum (90lux). |
| 4000 | Charger check. Runs charger at two set points. Checks that the charge current stays within allowed range (10mA to 4.5A). Checks that the solar voltage is stable (less than 50mV change between set points). |
| 8000 | LED fixture check. Enables one bank at a time. Checks that the LED voltage is between 6V and 28V. Checks that the current is close to the set intensity. If a single fixture is used, and an alternating flash pattern is programmed, the system will generate an error because it expecting to see current flowing through two fixtures in alternation. |

10.0 Customer Service and Warranty

The G Series products are covered by a limited warranty for the product excluding batteries, and a separate limited warranty for the batteries.

Visit carmanah.com for additional information or contact the customer support department.

Before contacting Carmanah's customer support department, please have the serial number of your system available, a brief description of the problem, as well as all details of the installation (location, pole type, type and quantity of fixtures, etc.) The serial number can be found on the label on the right side of the cabinet near the top, and on a label inside the cabinet on the EMS.

To contact Carmanah's Customer Support Department:

Mail: Carmanah Technologies Corporation
250 Bay Street
Victoria, BC, Canada
V9A 3K5

Phone: 1.250.380.0052
1.877.722.8877 (Toll Free in U.S. and Canada)

Fax: 1.250.380.0062

Email: customersupport@carmanah.com

Web: carmanah.com

10.1 Additional Products

Carmanah offers a variety of solar-powered and energy-efficient LED beacons and signs for the transportation industry. In addition to the G Series, the compact, self-contained E and F Series products are fully compatible with the G Series. For more information, please visit our website at carmanah.com.

10.2 Glossary

| | |
|----------------------|--|
| 3PD: | Third-Party Device, typically an accessory module that provides expanded functions to the product. Examples include time switches, modems and detection systems. |
| Autonomy: | The number of days or nights the system can continue to operate normally without any battery charging from the solar panels. |
| EMS: | Energy Management System. The electronic controller inside the product that is responsible for managing the solar input energy, battery charging, LED drivers and other power and operational functions. |
| Solar Engine: | The complete assembly consisting of the solar panel, batteries, EMS control module, wiring, fuses and mechanical enclosure. |
| UI/OBUI: | User Interface/On-Board User Interface. The 4-digit display and 3-button interface on the EMS that allows users to interact with the system programming. |



© 2021 Carmanah Technologies Corporation

Technical Support:

Email: customersupport@carmanah.com

Toll Free: 1.877.722.8877 (US & Canada)

Worldwide: 1.250.380.0052

Fax: 1.250.380.0062

Web: carmanah.com