

# RC33KNZA



Product Family	Refrigerator
Installation	Free standing
Category	Bottom Mount
Reference width	Until 60
Reference height	160 - 200
Sistema Total No - Frost	Yes
Cooling type	Total No Frost
Defrost	Automatic
Hinge type	Standard
Hinge position	Right
Reversible door	Yes
EAN code	8017709344832



## Aesthetics



Aesthetic	Universale	Side colour	Dark grey
Colour	Dark Grey Inox Look	Logo	Applied
Finishing	Fingerproof	Door shelves profile color	Dark Inox Look
Design	Flat	Drawers profile color	Dark Inox Look
Material	Steel Effect	Color of glass shelf profile	Dark Inox Look
Handle	Integrated	Display	LED
Logo colour	Silver	Display position	Interno (cella frigo)
Side material	Steel		

## Refrigerator compartment features



No. of adjustable shelves	3	Bottle shelf	Yes
Number of fruit and vegetables drawers	1	Type of crisper/vegetable drawers cover	Glass
Type of adjustable shelves	Glass	No. of lights refrigerator compartment	2
Type of crisper/vegetable drawers cover	Standard	Internal light in fridge	Yes
Crisper Cover	Yes	Type of internal light (fridge)	LED

## Refrigerator Inner Door

Number of adjustable door shelves	2	No. of bottle shelves	1
-----------------------------------	---	-----------------------	---

## Other Refrigerator features



Accessories	Egg tray	Fan	Yes
MultiFlow	Yes		

## Freezer compartment features

Number of drawers	3
-------------------	---

## Other Freezer features

Accessories	2 ice boxes
-------------	-------------

## Other technical features



Functions display	Fast freezing, ECO
Fast freezing button	Yes
Door open alarm	Yes
Type of temperature control	Electronic
No. of compressors	1
Refrigerant gas type	R600a
Type of compressor	Inverter
Refrigerant Quantity (gr)	50 g
Foam agent	Cyclopentane

## Performance / Energy Label - Reg. 2019

Total net volume	324 l	Airborne acoustical noise emissions	42 dB(A) re 1 pW
Sum of the volumes of the frozen compartment(s)	94 l	4 star - Freezing capacity	5,0 Kg/24h
Sum of the volumes of the chill compartment(s) and the unfrozen compartment(s)	230 l	Climate class	SN, T

## Electrical Connection

Plug	(F;E) Schuko	Voltage (V)	220-240 V
		Frequency (Hz)	50 Hz

Electrical connection rating 145 W

Power supply cable length 210 cm



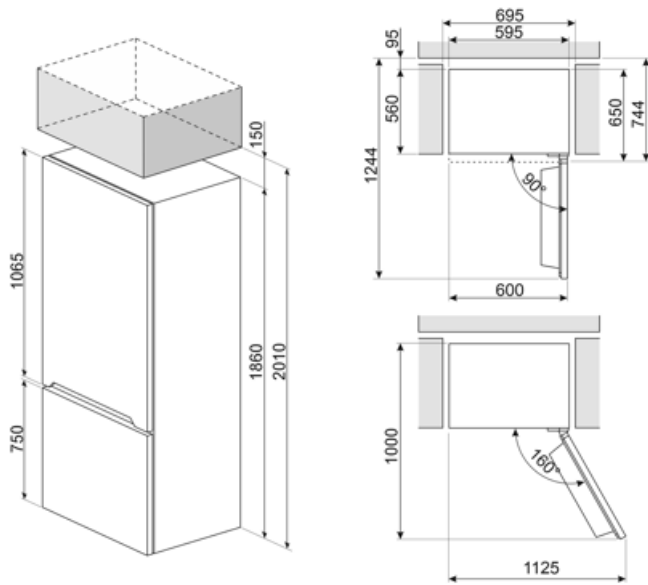





Current 1,1 A



---

## Symbols glossary

---

	The automatic defrost system works by automatically defrosting at regular intervals eliminating the need to defrost altogether.		LED display: to show programmes, functions and options selected and the time to the end of the cycle.
	Economical mode: Analyzes fridge functioning during the activation and optimizes the operating cycle in order to reduce power consumption.		Ventilated: Forced distribution of cold air in the refrigerator compartment, which allows even temperature distribution within the fridge.
	Fast freezing: The fast freezing function brings the temperature of the compartment down when activated a few hours prior to usage.		LED interior lighting: is a more energy efficient and long lasting way of illuminating the interior of the appliance.
	Smeg's evolution towards more intelligent and eco-friendly models has led to the choice of Inverter technology, which significantly reduces consumption.		Multiflow Cooling System: the Multiflow ventilation system allows an even distribution of cool air around the fridge cabinet.

---

## Benefit (TT)

---

### **No-Frost system**

The No Frost system prevents the formation of ice and contributes to better preservation of food in the refrigerator

### **Plastic multiflow system**

The Multiflow system ensures even distribution of cold air inside the refrigerator

### **Fan**

The fan contributes to an even distribution of air inside the refrigerator

### **Refrigerant gas R600a**

Environmentally friendly R600a refrigerant gas contributes to rapid cooling with lower energy consumption

### **Reversible door**

Reversible door ensures flexible installation and space optimisation

### **Refrigerator Internal lighting**

Interior lighting for perfect visibility of shelves in the refrigerator compartment

### **Fruit and vegetable drawer**

The fruit and vegetable drawer ensures the best storage conditions for fresh food, avoiding any contamination

### **Inverter compressor**

Inverter compressor reduces noise and vibration levels for a quiet and comfortable kitchen environment

Inverter compressor technology offers significant advantages for refrigeration systems, improving both performance and efficiency. Better temperature control ensures a more stable and constant indoor environment, preserving the freshness of food. This technology also results in reduced energy consumption, as the compressor adjusts its speed according to cooling needs.

### **Internal display**

Internal display for targeted temperature control and a clean, minimalist design