

2014

A4/S4

Quick Reference
Specification Book

2014 Audi A4/S4 Quick Reference Specification Book

TABLE OF CONTENTS

General Information	1
Decimal and Metric Equivalents	1
Tightening Specification.....	2
Warnings and Cautions	4
Vehicle Identification.....	9
VIN on Lower Edge of Front Window	9
VIN Decoder	10
Vehicle Data Sticker	11
Sales Codes	12
Engine Codes	12
Transmission Codes	12
Vehicle Lifting	13
Lifting Points for Lifting Platform and Trolley Jack.....	13
Engine Mechanical – 2.0L CAED, CPMB	15
General, Technical Data – 2.0L CAED, CPMB	15
Engine Number Location	15
Engine Data	15
Engine Assembly – 2.0L CAED, CPMB.....	16
Fastener Tightening Specifications.....	16
Securing Engine to Transmission	16
Crankshaft, Cylinder Block – 2.0L CAED, CPMB	18
Fastener Tightening Specifications.....	18
Accessory Assembly Bracket with Hydraulic Power Steering Tightening Specifications	19
Accessory Assembly Bracket with Electro-Mechanical Power Steering Tightening Specifications.....	20
Transmission Side Sealing Flange - Tightening Sequence, with 8 Bolts Specifications.....	21
Transmission Side Sealing Flange - Tightening Sequence, with 6 Bolts Specifications.....	22
Cylinder Block Bearing Shell Identification	23
Bearing Cap Bearing Shell Identification	25
Piston Ring End Gaps	26
Piston Ring Clearance.....	26
Piston and Cylinder Dimensions.....	26
Piston and Connecting Rod Tightening Specifications	26

Crankshaft Dimensions	26
Crankshaft Assembly Tightening Specifications	27
Cylinder Head, Valvetrain – 2.0L CAED, CPMB	28
Fastener Tightening Specifications.....	28
Cylinder Head, with Wrench Access –	
Removal Sequence.....	29
Cylinder Head, without Wrench Access –	
Removal Sequence.....	31
Cylinder Head, with Wrench Access –	
Tightening Specifications	32
Cylinder Head, without Wrench Access – Specifications	34
Cylinder Head Cover Loosening Sequence	35
Cylinder Head Cover Tightening Specifications	35
Compression Pressures	36
Valve Dimensions	36
Upper Timing Chain Cover Tightening Specification	37
Intermediate Sprocket Tightening Sequence.....	38
Crankcase Ventilation, Tightening Sequence	39
Lower Timing Chain Cover - Tightening Sequence	
for 15 Bolts Specifications.....	40
Lower Timing Chain Guard - Tightening Sequence	
for 8 Bolts Specifications.....	41
Engine Lubrication – 2.0L CAED, CPMB.....	42
Fastener Tightening Specifications.....	42
Oil Pan Upper Section Tightening Specifications	42
Oil Pan Tightening Specifications	43
Oil Separator Tightening Specification	43
Fuel Injection and Ignition – 2.0L CAED, CPMB	44
Fuel Injection System Data.....	44
Fastener Tightening Specifications – Fuel Injection	44
Fastener Tightening Specifications – Ignition	45
Engine Cooling – 2.0L CAED, CPMB	45
Fastener Tightening Specifications.....	45
Coolant Pump Tightening Specifications	46
Fuel Supply System – 2.0L CAED, CPMB	46
Fastener Tightening Specifications.....	46
Turbocharger – 2.0L CAED, CPMB	47
Fastener Tightening Specifications.....	47
Turbocharger Tightening Specifications	48
Exhaust System – 2.0L CAED, CPMB	48
Exhaust System Tightening Specifications.....	48

Engine Mechanical – 3.0L CGXC, CTUB.....	49
General, Technical Data – 3.0L CGXC, CTUB	49
Engine Number Location	49
Engine Data	49
Engine Assembly – 3.0L CGXC.....	50
Fastener Tightening Specifications.....	50
Engine to Manual Transmission Fastener Tightening Specifications	51
Engine to S tronic Transmission 0B5 Fastener Tightening Specifications	52
Crankshaft/Cylinder Block – 3.0L CGXC	53
Fastener Tightening Specifications.....	53
Ribbed Belt Pulley Side Sealing Flange Tightening Specifications	54
Crankshaft Assembly Guide Frame Tightening Specifications	55
Crankshaft Dimensions	56
Crankshaft Axial Play.....	56
Crankshaft Radial Play	56
Connecting Rod Radial Clearance	56
Piston Ring End Gap Dimensions	56
Piston Ring Side Clearance Dimensions.....	56
Piston and Cylinder Dimensions.....	56
Fastener Tightening Specifications.....	57
Valve Dimensions	58
Compression Pressures	58
Cylinder Head Tightening Specifications	59
Left Cylinder Head Cover Tightening Specification	60
Right Cylinder Head Cover Tightening Specification.....	60
Left Timing Chain Cover Tightening Specifications	61
Right Timing Chain Cover Tightening Specifications.....	61
Lower Timing Chain Cover Tightening Specifications	62
Camshaft Guide Frame Tightening Specifications	64
Engine Lubrication – 3.0L CGXC, CTUB.....	65
Fastener Tightening Specifications.....	65
Upper Oil Pan Tightening Specifications	66
Lower Oil Pan Tightening Specifications	67
Fuel Injection – 3.0L CGXC.....	67
Fuel Injection System Test Data	67
Fastener Tightening Specifications.....	68
Lower Intake Manifold Tightening Specification	69

Ignition – 3.0L CGXC	70
Ignition System Test Data	70
Fastener Tightening Specifications	70
Fuel Supply System – 3.0L CGXC	70
Fastener Tightening Specifications	70
Engine Cooling – 3.0L CGXC	71
Fastener Tightening Specifications	71
Supercharger – 3.0L CGXC	72
Fastener Tightening Specifications	72
Supercharger Tightening Specifications	72
Exhaust System – 3.0L CGXC	73
Fastener Tightening Specifications	73
Left Exhaust Manifold Tightening Specifications	74
Right Exhaust Manifold Tightening Specifications	75
Manual Transmission – 0B2	76
General, Technical Data – 0B2	76
Transmission Identification	76
Code Letters, Assembly Allocation, Ratios, Capacities	78
Transmission Specifications	79
Securing Transmission to Engine	80
Clutch – 0B2	81
Fastener Tightening Specifications	81
Fastener Tightening Specifications –	
Internal Components	81
Controls, Housing – 0B2	81
Fastener Tightening Specifications	81
Fastener Tightening Specifications –	
Internal Components	82
Gears, Shafts – 0B2	83
Fastener Tightening Specifications	83
Rear Final Drive, Differential – 0B2	84
Fastener Tightening Specifications	84
Fastener Tightening Specifications –	
Internal Components	84
Manual Transmission – 0B4	85
General, Technical Data – 0B4	85
Transmission Identification	85
Engine Codes, Transmission Allocation, Ratios	
and Capacities	87
Securing Transmission to Engine	88

Clutch – 0B4	89
Fastener Tightening Specifications.....	89
Fastener Tightening Specifications – Internal Components.....	90
Controls, Housing – 0B4.....	90
Fastener Tightening Specifications.....	90
Fastener Tightening Specifications – Internal Components.....	91
Gears, Shafts – 0B4	92
Fastener Tightening Specifications.....	92
Rear Final Drive, Differential – 0B4	92
Fastener Tightening Specifications.....	92
Fastener Tightening Specifications – Internal Components.....	92
Direct Shift Transmission, S Tronic – 0B5	93
General, Technical Data – 0B5.....	93
Transmission Identification	93
Code Letters, Transmission Allocations, Ratios and Equipment.....	94
Securing Transmission to Engine	95
Clutch – 0B5	96
Fastener Tightening Specification	96
Tightening Specification and Sequence for the Dual Clutch and Clutch Cover	96
Fastener Tightening Specifications.....	97
Fastener Tightening Specifications – Internal Components.....	98
Gears, Shafts – 0B5	98
Fastener Tightening Specifications.....	98
ATF Oil Pan Tightening Specifications.....	99
Mechatronic Tightening Specification	100
Circuit Board 1 Tightening Specification	101
Circuit Board 2 Tightening Specification.....	102
Transmission Intermediate Housing Tightening Specification.....	103
Rear Final Drive, Differential – 0B5	103
Fastener Tightening Specifications.....	103
Front Final Drive Cover Tightening Specifications.....	104
Center Differential Housing - Attached Driveshaft Tightening Specifications	105
Center Differential Housing - Bolted Driveshaft Tightening Specifications	106

Continuously Variable

Automatic Transmission – 0AW	107
Transmission Identification	107
Engine Codes, Transmission Allocations, Ratios and Equipment	108
Securing Transmission to Engine	109
Controls, Housing – 0AW	110
Fastener Tightening Specifications	110
Gears, Hydraulic Controls – 0AW	111
Fastener Tightening Specifications	111
Rear Final Drive, Differential – 0AW	111
Fastener Tightening Specifications	111
Front Final Drive Cover Tightening Specifications	112
Automatic Transmission – 0BK	113
Transmission Identification	113
Code Letters, Transmission Allocations, Ratios and Equipment	115
Controls, Housing – 0BK	116
Securing Transmission to Engine	116
Fastener Tightening Specifications	117
Fastener Tightening Specifications	117
ATF Oil Pan Tightening Specifications	118
Mechatronic Tightening Specification	119
Fastener Tightening Specifications	119
Front Final Drive Cover Tightening Specifications	120
Center Differential Housing Tightening Specification	121
Rear Final Drive – 0BC, 0BD, 0BE, 0BF	122
General, Technical Data – 0BC	122
Rear Final Drive Identification	122
Final Drive Identification	123
Rear Final Drive Code and Date of Manufacture	125
General, Technical Data – 0BD	126
Rear Final Drive Identification	126
Example	127
General, Technical Data – 0BE, 0BF	128
Rear Final Drive Identification	128
Example	129
Rear Final Drive 0BC Transmission Allocations, Ratios, Capacities	130
Rear Final Drive 0BD Transmission Allocations, Ratios, Capacities	130

Rear Final Drive 0BF Transmission Allocations, Ratios, Capacities	131
Fastener Tightening Specifications.....	133
Driveshaft to Rear Final Drive Tightening Specification	134
Suspension, Wheels, Steering	135
General Specifications.....	135
Chassis.....	135
Steering	135
Front Axle – Curb Weight Data	136
Front Suspension	137
Fastener Tightening Specifications.....	137
Rear Suspension	139
Fastener Tightening Specifications.....	139
Self-Leveling Suspension	141
Fastener Tightening Specifications.....	141
Wheels, Tires, Wheel Alignment.....	141
Fastener Tightening Specifications.....	141
Wheel Bolt Tightening Specifications	142
Wheel Alignment Data	142
Steering	145
Steering Gear – Technical Data.....	145
Fastener Tightening Specifications.....	145
Brake System.....	147
General, Technical Data	147
Antilock Brake System.....	148
Fastener Tightening Specifications.....	148
Mechanical Components	148
Fastener Tightening Specifications.....	148
Hydraulic Components	150
Tightening Specifications.....	150
Body.....	151
Air Gap Body Dimensions	151
Front Gap Dimensions.....	151
Rear Gap Dimensions	152
Rear Gap Dimensions – Avant	153
Body Exterior	154
Body Front Tightening Specifications	154
Hood, Lids Tightening Specifications.....	154
Front Doors, Central Locking System Tightening Specifications	155

Rear Doors Tightening Specification	155
Sunroof Tightening Specifications	155
Bumpers Tightening Specifications	156
Glass, Window Regulators Tightening Specifications	156
Exterior Equipment Tightening Specifications	157
Body Interior	158
Interior Equipment Tightening Specifications	158
Passenger Protection, Airbags, Seat Belts Tightening Specifications	159
Interior Trim Tightening Specifications	160
Seat Frames Tightening Specifications	162
Heating, Ventilation & Air Conditioning	164
General, Technical Data	164
Refrigerant (PAG) Oil Capacities	164
Refrigerant Oil Distribution	164
Refrigerant R134a Vapor Pressure Table	165
Air Conditioning	166
Fastener Tightening Specifications	166
Electrical System	167
Communication	167
Tightening Specifications	167
Electrical Equipment	167
Battery, Starter, Generator, Cruise Control Tightening Specifications	167
Instruments Tightening Specifications	168
Windshield Wiper/Washer System Tightening Specifications	168
Windshield Wiper Motor Bolt Tightening Specification and Sequence	169
Washer Fluid Reservoir Bolt Tightening Specifications and Sequence	170
Exterior Lights, Switches Tightening Specifications	171
Interior Lights, Switches Tightening Specifications	172
DTC CHART	173
Engine Code CAED, CPMB	173
Fuel and Air Mixture, Additional Emission Regulations	173
Ignition System	184
Additional Exhaust Regulation	186
Speed and Idle Control	187
Control Module and Output Signals	189

Fuel and Air Ratios Control Module	193
Ignition System	196
Additional Emissions Regulations	197
Transmission	197
DTC CHART.....	199
Engine Code CGXC, CTUB.....	199
Fuel and Air Mixture,	
Additional Emission Regulation.....	199
Ignition System	212
Additional Exhaust Regulation.....	215
Speed and Idle Control.....	216
Control Module and Output Signals.....	217
Fuel and Air Ratios Control Module.....	220
Ignition System	224
Additional Emissions Regulations	225
Transmission	225

GENERAL INFORMATION

Decimal and Metric Equivalents

Distance/Length

To calculate: mm x 0.03937 = in.

mm	in.	mm	in.	mm	in.	mm	in.
0.002	0.00008	0.01	0.0004	0.1	0.004	1	0.04
0.004	0.00016	0.02	0.0008	0.2	0.008	2	0.08
0.006	0.00024	0.03	0.0012	0.3	0.012	3	0.12
0.008	0.00031	0.04	0.0016	0.4	0.016	4	0.16
0.010	0.00039	0.05	0.0020	0.5	0.020	5	0.20
0.020	0.00079	0.06	0.0024	0.6	0.024	6	0.24
0.030	0.00118	0.07	0.0028	0.7	0.028	7	0.28
0.040	0.00157	0.08	0.0031	0.8	0.031	8	0.31
0.050	0.00197	0.09	0.0035	0.9	0.035	9	0.35
0.060	0.00236	0.10	0.0039	1.0	0.039	10	0.39
0.070	0.00276	0.20	0.0079	2.0	0.079	20	0.79
0.080	0.00315	0.30	0.0118	3.0	0.118	30	1.18
0.090	0.00354	0.40	0.0157	4.0	0.157	40	1.57
0.100	0.00394	0.50	0.0197	5.0	0.197	50	1.97
0.200	0.00787	0.60	0.0236	6.0	0.236	60	2.36
0.300	0.01181	0.70	0.0276	7.0	0.276	70	2.76
0.400	0.01575	0.80	0.0315	8.0	0.315	80	3.15
0.500	0.01969	0.90	0.0354	9.0	0.354	90	3.54
0.600	0.02362	1.00	0.0394	10.0	0.394	100	3.94
0.700	0.02756	2.00	0.0787	20.0	0.787		
0.800	0.03150	3.00	0.1181	30.0	1.181		
0.900	0.03543	4.00	0.1575	40.0	1.575		
1.000	0.03937	5.00	0.1969	50.0	1.969		
2.000	0.07874	6.00	0.2362	60.0	2.362		
3.000	0.11811	7.00	0.2756	70.0	2.756		
4.000	0.15748	8.00	0.3150	80.0	3.150		
5.000	0.19685	9.00	0.3543	90.0	3.543		
6.000	0.23622	10.00	0.3937	100.0	3.937		
7.000	0.27559	20.00	0.7874				
8.000	0.31496	30.00	1.1811				
9.000	0.35433	40.00	1.5748				
10.000	0.39370	50.00	1.9685				
20.000	0.78740	60.00	2.3622				
30.000	1.18110	70.00	2.7559				
40.000	1.57480	80.00	3.1496				
50.000	1.96850	90.00	3.5433				
60.000	2.36220	100.00	3.9370				
70.000	2.75591						
80.000	3.14961						
90.000	3.54331						
100.000	3.93701						

Tightening Specification

N·m-to-lb·ft (ft·lb)

To calculate: N·m x 0.738 = lb·ft

N·m	lb·ft (ft·lb)	N·m	lb·ft (ft·lb)	N·m	lb·ft (ft·lb)
10	7	55	41	100	74
11	8	56	41	105	77
12	9	57	42	110	81
13	10	58	43	115	85
14	10	59	44	120	89
15	11	60	44	125	92
16	12	61	45	130	96
17	13	62	46	135	100
18	13	63	46	140	103
19	14	64	47	145	107
20	15	65	48	150	111
21	15	66	49	155	114
22	16	67	49	160	118
23	17	68	50	165	122
24	18	69	51	170	125
25	18	70	52	175	129
26	19	71	52	180	133
27	20	72	53	185	136
28	21	73	54	190	140
29	21	74	55	195	144
30	22	75	55	200	148
31	23	76	56	205	151
32	24	77	57	210	155
33	24	78	58	215	159
34	25	79	58	220	162
35	26	80	59	225	166
36	27	81	60	230	170
37	27	82	60	235	173
38	28	83	61	240	177
39	29	84	62	245	181
40	30	85	63	250	184
41	30	86	63	260	192
42	31	87	64	270	199
43	32	88	65	280	207
44	32	89	66	290	214
45	33	90	66	300	221
46	34	91	67	310	229
47	35	92	68	320	236
48	35	93	69	330	243
49	36	94	69	340	251
50	37	95	70	350	258
51	38	96	71	360	266
52	38	97	72	370	273
53	39	98	72	380	280
54	40	99	73	390	288
55	41	100	74	400	295

N·m-to-lb·in (in·lb), kg·cm

To calculate: $N \cdot m \times 8.85 = lb \cdot in$ • $N \cdot m \times 10.20 = kg \cdot cm$

N·m	lb·in (in·lb)	kg·cm	N·m	lb·in (in·lb)	kg·cm
1	9	10	26	230	265
2	18	20	27	239	275
3	27	31	28	248	286
4	35	41	29	257	296
5	44	51	30	266	306
6	53	61	31	274	316
7	62	71	32	283	326
8	71	82	33	292	337
9	80	92	34	301	347
10	89	102	35	310	357
11	97	112	36	319	367
12	106	122	37	327	377
13	115	133	38	336	387
14	124	143	39	345	398
15	133	153	40	354	408
16	142	163	41	363	418
17	150	173	42	372	428
18	159	184	43	381	438
19	168	194	44	389	449
20	177	204	45	398	459
21	186	214	46	407	469
22	195	224	47	416	479
23	204	235	48	425	489
24	212	245	49	434	500
25	221	255	50	443	510

N·cm-to-lb·in (in·lb), kg·cm

To calculate: $N \cdot cm \times 0.089 = lb \cdot in$ • $N \cdot cm \times 0.102 = kg \cdot cm$

N·cm	lb·in (in·lb)	kg·cm	N·cm	lb·in (in·lb)	kg·cm
50	4	5	250	22	25
60	5	6	300	27	31
70	6	7	350	31	36
80	7	8	400	35	41
90	8	9	450	40	46
100	9	10	500	44	51
110	10	11	550	49	56
120	11	12	600	53	61
130	12	13	650	58	66
140	12	14	700	62	71
150	13	15	750	66	76
160	14	16	800	71	82
170	15	17	850	75	87
180	16	18	900	80	92
190	17	19	950	84	97
200	18	20	1000	89	102

kg·cm-to-lb·in (in·lb), N·cm

To calculate: $\text{kg}\cdot\text{cm} \times 0.868 = \text{lb}\cdot\text{in}$ • $\text{kg}\cdot\text{cm} \times 9.81 = \text{N}\cdot\text{cm}$

kg·cm	lb·in (in·lb)	N·cm		kg·cm	lb·in (in·lb)	N·cm
5	4	49		110	95	1079
6	5	59		120	104	1177
7	6	69		130	113	1275
8	7	78		140	122	1373
9	8	88		150	130	1471
10	9	98		160	139	1569
20	17	196		170	148	1667
30	26	294		180	156	1765
40	35	392		190	165	1863
50	43	490		200	174	1961
60	52	588		210	182	2059
70	61	686		220	191	2157
80	69	785		230	200	2256
90	78	883		240	208	2354
100	87	981		250	217	2452

Warnings and Cautions

WARNINGS

- Some repairs may be beyond your capability. If you lack the skills, tools and equipment, or a suitable workplace for any procedure described in this manual, we suggest you leave such repairs to an authorized dealer service department or other qualified shop.
- Do not reuse any fasteners that have become worn or deformed during normal use. Many fasteners are designed to be used only once and become unreliable and may fail when used a second time. This includes, but is not limited to, nuts, bolts, washers, self-locking nuts or bolts, circlips and cotter pins. Always replace these fasteners with new parts.
- Never work under a lifted car unless it is solidly supported on stands designed for the purpose. Do not support a car on cinder blocks, hollow tiles or other props that may crumble under continuous load. Never work under a car that is supported solely by a jack. Never work under the car while the engine is running.
- If you are going to work under a car on the ground, make sure the ground is level. Block the wheels to keep the car from rolling. Disconnect the battery negative (-) terminal (ground strap) to prevent others from starting the car while you are under it.

- Never run the engine unless the work area is well ventilated. Carbon monoxide kills.
- Remove rings, bracelets and other jewelry so they cannot cause electrical shorts, get caught in running machinery, or be crushed by heavy parts.
- Tie back long hair. Do not wear a necktie, a scarf, loose clothing, or a necklace when you work near machine tools or running engines. If your hair, clothing, or jewelry were to get caught in the machinery, severe injury could result.
- Do not attempt to work on your car if you do not feel well. You increase the danger of injury to yourself and others if you are tired, upset, or have taken medication or any other substance that may keep you from being fully alert.
- Illuminate your work area adequately but safely. Use a portable safety light for working inside or under the car. Make sure the bulb is enclosed by a wire cage. The hot filament of an accidentally broken bulb can ignite spilled fuel, vapors or oil.
- Use a suitable container to catch draining fuel, oil, or brake fluid. Do not use food or beverage containers that might mislead someone into drinking from them. Store flammable fluids away from fire hazards. Wipe up spills at once, but do not store oily rags which can ignite and burn spontaneously.
- Always observe good workshop practices. Wear goggles when you operate machine tools or work with battery acid. Wear gloves or other protective clothing whenever the job requires working with harmful substances.
- Greases, lubricants and other automotive chemicals contain toxic substances, many of which are absorbed directly through the skin. Read the manufacturer's instructions and warnings carefully. Use hand and eye protection. Avoid direct skin contact
- Disconnect the battery negative (-) terminal (ground strap) whenever you work on the fuel or electrical system. Do not smoke or work near heaters or other fire hazards. Keep an approved fire extinguisher handy.
- Friction materials (such as brake pads or shoes or clutch discs) contain asbestos fibers or other friction materials. Do not create dust by grinding, sanding, or cleaning with compressed air. Avoid breathing dust. Breathing any friction material dust can lead to serious diseases and may result in death.

(WARNINGS cont'd on next page)

WARNINGS *(cont'd)*

- Batteries give off explosive hydrogen gas during charging. Keep sparks, lighted matches and open flame away from the top of the battery. If hydrogen gas escaping from the cap vents is ignited, it ignites the gas trapped in the cells and causes the battery to explode.
- Connect and disconnect battery cables, jumper cables or a battery charger only with the ignition off. Do not disconnect the battery while the engine is running.
- Do not quick-charge the battery (for boost starting) for longer than one minute. Wait at least one minute before boosting the battery a second time.
- Do not allow battery charging voltage to exceed 16.5 volts. If the battery begins producing gas or boiling violently, reduce the charging rate. Boosting a sulfated battery at a high charging rate can cause an explosion.
- The A/C system is filled with chemical refrigerant, which is hazardous. The A/C system should be serviced only by trained technicians using approved refrigerant recovery/recycling equipment, trained in related safety precautions, and familiar with regulations governing the discharging and disposal of automotive chemical refrigerants.
- Do not expose any part of the A/C system to high temperatures such as open flame. Excessive heat increases system pressure and may cause the system to burst.
- Some aerosol tire inflators are highly flammable. Be extremely cautious when repairing a tire that may have been inflated using an aerosol tire inflator. Keep sparks, open flame or other sources of ignition away from the tire repair area. Inflate and deflate the tire at least four times before breaking the bead from the rim. Completely remove the tire from the rim before attempting any repair.
- Some cars are equipped with a Supplemental Restraint System (SRS) that automatically deploys airbags and pyrotechnic seat belt tensioners in the event of a frontal or side impact. These are explosive devices. Handled improperly or without adequate safeguards, they can be accidentally activated and cause serious injury.
- The ignition system produces high voltages that can be fatal. Avoid contact with exposed terminals and use extreme care when working on a car with the engine running or the ignition on.

- Place jack stands only at locations specified by manufacturer. The vehicle lifting jack supplied with the vehicle is intended for tire changes only. Use a heavy duty floor jack to lift the vehicle before installing jack stands.
- Battery acid (electrolyte) can cause severe burns. Flush contact area with water, seek medical attention.
- Aerosol cleaners and solvents may contain hazardous or deadly vapors and are highly flammable. Use only in a well ventilated area. Do not use on hot surfaces (such as engines or brakes).
- Do not remove coolant reservoir or radiator cap with the engine hot. Burns and engine damage may occur.

CAUTIONS

- If you lack the skills, tools and equipment, or a suitable workshop for any procedure described in this manual, we suggest you leave such repairs to an authorized dealer or other qualified shop.
- Before starting a job, make certain that you have all the necessary tools and parts on hand. Read all the instructions thoroughly and do not attempt shortcuts. Use tools appropriate to the work and use only replacement parts meeting original specifications. Makeshift tools, parts and procedures will not make good repairs.
- Use pneumatic and electric tools only to loosen threaded parts and fasteners. Never use these tools to tighten fasteners, especially on light alloy parts. Always use a torque wrench to tighten fasteners to the Tightening Specification specification listed.
- Be mindful of the environment and ecology. Before you drain the crankcase, find out the proper way to dispose of the oil. Do not pour oil onto the ground, down a drain, or into a stream, pond or lake. Dispose of in accordance with Federal, State and Local laws.
- The control module for the Anti-lock Brake System (ABS) cannot withstand temperatures from a paint-drying booth or a heat lamp in excess of 95°C (203°F) and should not be subjected to temperatures exceeding 85°C (185°F) for more than two hours.
- Before doing any electrical welding on cars equipped with ABS, disconnect the battery negative (-) terminal (ground strap) and the ABS control module connector.

(CAUTIONS cont'd on next page)

CAUTIONS *(cont'd)*

- Always make sure the ignition is off before disconnecting battery.
- Label battery cables before disconnecting. On some models, battery cables are not color coded.
- Disconnecting the battery may erase fault code(s) stored in control module memory. Check for fault codes prior to disconnecting the battery cables.
- If a normal or rapid charger is used to charge the battery, disconnect the battery and remove it from the vehicle to avoid damaging paint and upholstery.
- Do not quick-charge the battery (for boost starting) for longer than one minute. Wait at least one minute before boosting the battery a second time.
- Connect and disconnect a battery charger only with the battery charger switched off.
- Sealed or "maintenance free" batteries should be slow-charged only, at an amperage rate that is approximately 10% of the battery's ampere-hour (Ah) rating.
- Do not allow battery charging voltage to exceed 16.5 volts. If the battery begins producing gas or boiling violently, reduce the charging rate. Boosting a sulfated battery at a high charging rate can cause an explosion.

VEHICLE IDENTIFICATION

VIN on Lower Edge of Front Window

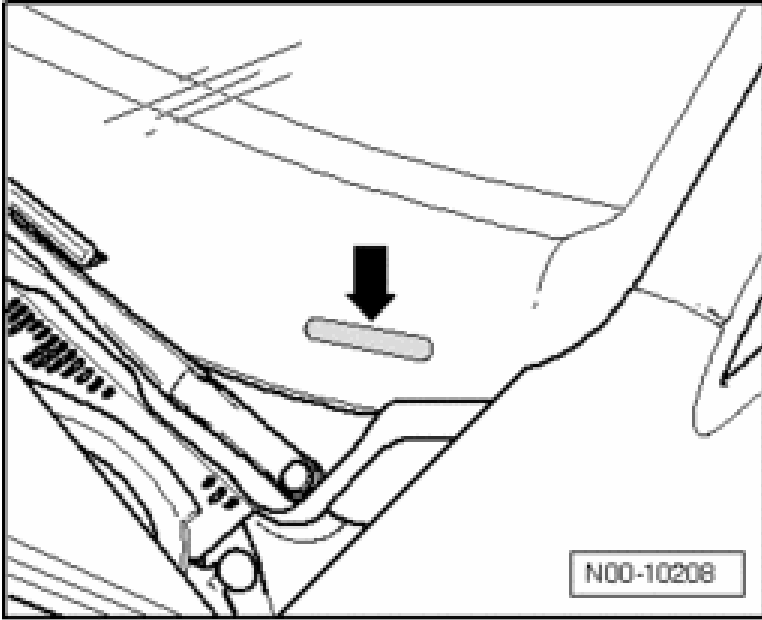

The VIN ➔ is on the left side of the vehicle in the area of the windshield wiper mount. It is visible from outside.

Vehicle
Identification

VIN Decoder

2014 Audi VIN Decoder

Series:	Mfg. Make (1-3)	Series	Engine	Restraint system	Model (7&8)	Check digit	Model year	Assembly plant	Sequential production number (position 12 - 17)
A - A4 Premium A5 Cab Premium A6 Sedan R8 V8 4.2 Coupe**** B - A4 Premium q S4 Premium q TT/TTTS/TRS Cpe Prem + quattro C - A5 Premium q A5 Cab Premium q A6 2.0T Premium S5 Cab Premium q Q5 2.0T Premium Q5 Hybrid Prestige Q5 TDI Premium** S05 Premium** Q7 3.0T TDI Prem U - allroad Premium q R55 Cpe & Cab*** A4 Manual Prem q S4 Manual Prem** S8 Sedan Q5 3.0T Premium Q5 TDI Prem + S-Line R9 V8 4.2 Coupe - Manual E - A4 Premium R8 V10 5.2 Spyder**** A6 Premium q S6 R8 V8 4.2 Coupe**** G - A5 Manual Prem q S5 Manual Prem q A6 2.0T Premium q R8 V10 5.2 Coupe - Manual H - A4 Manual Prem q A4 Prestige q J - A4 Premium** A5 Cab Premium** A6 Cab Premium** R8 V10 5.2 Coupe - Manual	L - A5 Premium** q A5 Cab Premium** q Q5 2.0T Premium** Q7 3.0T TDI Prem** R8 V10 5.2 Coupe - Manual M - A4 Cab Premium** q A5 Premium** q S-Line S - TT/TTTS/TRS Rstr. Prem + q A5 Manual Prem + q S-Line R8 V8 4.2 Spyder**** R8 V10 5.2 Spyder - Manual W - allroad Premium q A5 Cab Prestige R5 V6 4.2 Spyder - Manual V - allroad Prestige q S5 Prestige q S5 Cab Prestige q Q5 TDI Prestige S05 Prestige Q7 TDI Prestige W - A5 Prestige q S-Line A5 Cab Prestige q A6 Prestige q S7 2 - A7 Prestige q R8 V10 5.2 Plus Coupe - Manual 3 - S5 Man Prestige q 4 - A4 Man Prest q A4 allroad Premium q	WUW - Hungary, Pass. Car WUA - Aust. - Europe, Multi-Purpose Pass. Car WAT - Aust. - Europe, Multi-Purpose Pass. Car WWA - Europe, Multi-Purpose Pass. Car	FC (4G)** = A6 / S6 / A7 / S7 / RS7 FD (4H) = A5 / S5 FE (4L) = Audi Q7 FG (4Z) = R8 FH (8F) = A5 / S5 / R55 Cab FK (6J) = TT / TTS FL (8K)** = A4 / S4 FP (8S) = Audi Q5 FR (8T) = A5 / S5 /	See back	Calculate per NHTSA Code	2014	Ingolstadt Bratislava Neckarsulm Gyor	F = 4 cyl 2.0L 220hp (CAED) A4 CVT / A4 q / A5 Cpe q / A5 Cab / A6 CVT (C7) / A6 q / G = 4 cyl 2.0L 211hp (CETA) TT Cpe q / TT Rstr q H = 4 cyl 2.0L 220hp (CPMB) A4 q / A5 Cpe q / A5 Cab q / Allroad / Q5 ♦♦ J = V6 3.0L 310hp (CTUA) A6 q (C7) / A7 q K = V6 3.0L 333hp (CTUB) S4 / S5 / S5 Cab / A6 / A8 L = V6 3.0L 272hp (CTUC) Q5 M = V6 3.0L 354hp (CTUD) S05 N = V6 3.0L 333hp (CTVA) Q7 P = 4 cyl 2.0L 262hp (CDMA) TTS Cpe/Rstr Q = V6 3.0L TDI 240hp (CPNB) A8 R = V6 3.0L TDI 240hp (CPNA) A8 S = V6 3.0L TDI 240hp (CPNB) A6 / A7 Sportback, Q5 T = V10 5.2L 550hp (CTPA) R8 Coupe U = V10 5.2L 525hp (CTPA) R8 / R8 Spyder ♦♦♦ V = V8 4.2L 430hp (CNDM) R8 / R8 Spyder W = V10 5.2L 525hp (CTVA) R8 X = 4 cyl 2.0L 262hp (CDMA) TTS Cpe/Rstr Y = V8 4.0L 420hp (CEUA) A6 / A8 Z = V8 4.0L 420hp (CEUC) S6 / S7 Sportback (C7) 1 = V8 4.0L 520hp (CETA) S4 2 = V8 4.0L 520hp (CORA) R57 Sportback (C7) 3 = V8 4.0L 520hp (CEA) A8L (D4) 4 = V8 4.2L 450hp (CFS) R55 Cpe/Cab 5 or C = 4 cyl 2.0L 211hp + 40 kW (CHJA) Q5	

* 7th VIN character is alphabetic for CDN, Mex, and US 2010 and later vehicles. RDW model characters are listed in parenthesis (), for reference only.

** A4 allroad models are identified by WMI code of "WUA". All other A4 models are identified by WMI code of "WUW".

*** R55 Cabriolet, R55 Coupe, R57 and R8 models are identified by WMI code of "WUA".

**** R8 Coupe 4.2 and 5.2 models and R8 Spyder 4.2 and 5.2 models may use

July 15, 2013 (Rev 2)

♦ The following 2.0T models are E85 Flex-Fuel capable: A4 2.0T quattro automatic, allroad 2.0T quattro, A5 2.0T Cabriolet quattro, A5 2.0T coupe quattro automatic, Q5 2.0T

♦♦ Some early production R8 V10 Coupes with manual transmission vehicles used a 4th and 5th character combination of "GU" instead of "GN".

♦♦♦ Some early production vehicles use the character "C" instead of "T".

2014 Audi VIN Decoder

Series:	Mfg. Make (1-3)	Series	Engine	Restraint system	Model (7&8)	Check digit	Model year	Assembly plant	Sequential production number (position 12 - 17)
K = 1989 L = 1990 M = 1991 N = 1992 P = 1993 R = 1994 S = 1995 T = 1996 V = 1997 W = 1998 X = 1999 Y = 2000 1 = 2001 2 = 2002 3 = 2003 4 = 2004 5 = 2005 6 = 2006 7 = 2007 8 = 2008 9 = 2009 A = 2010 B = 2011 C = 2012 D = 2013 E = 2014	1 Mfg. Make (1-3) 2 3 4 5 Series 6 Engine 7 Model (7&8) 8 9 Check digit 10 Model year 11 Assembly plant 12 13 14 15 16 17 Sequential production number (position 12 - 17)	Calculate per NHTSA Code	Sequential Product Number						

2014 Restraint System:

All = Active - Dr/Pass, AirBag - Dr/Pass, Advanced Front AirBag

A (A5 / S5 / R55 Cab, TT / TTS, R8) = Side AirBags Front, Knee AirBags Front, Side Guard Air Curtain, Knee AirBags Front

A (A6 / S6) = Side AirBags Front, Side Guard Air Curtain, Knee AirBag

A (R8) = Side AirBags Front, Knee AirBags Front

A (A4 / S4 / A6 / S6, A7 / S7 / RS7) = Side AirBags Front, Side Guard Air Curtain, Knee AirBag

B (A4 / S4, A6 / S6, A7 / S7 / RS7) = Side AirBags Front & Rear, Side Guard Air Curtain, Knee AirBag

B (Q5, Q7) = Side AirBags Front & Rear, Side Guard Air Curtain

Vehicle Data Sticker

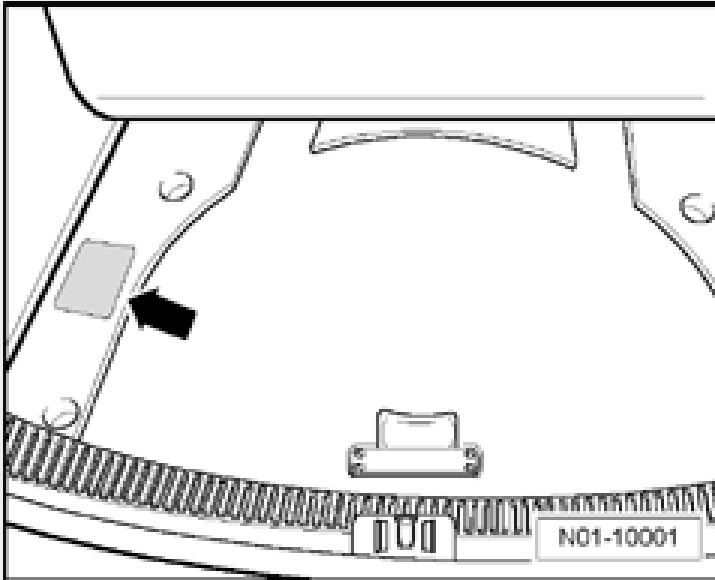

The vehicle data sticker ➔ is located in the left rear of vehicle in the spare wheel well under the foam storage tray. The vehicle data sticker can also be found in the customer's service schedule.

Vehicle
Identification

SALES CODES

Engine Codes

CAED, CPMB	2.0L 4-cylinder
CGXC, CTUB	3.0L 6-cylinder

Transmission Codes

0AW	Continuously variable automatic transmission
0B2, 0B4	6-speed manual transmission
0B5	7-speed direct shift automatic transmission
0BK	8-speed automatic transmission

VEHICLE LIFTING

Lifting Points for Lifting Platform and Trolley Jack

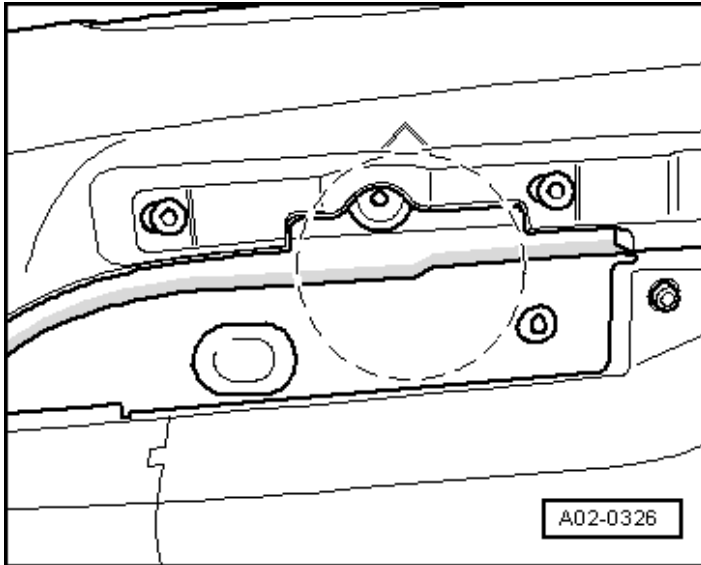

Front: At the side member vertical reinforcement area.
Marking is for the onboard vehicle jack.

Sales
Codes

Vehicle
Lifting

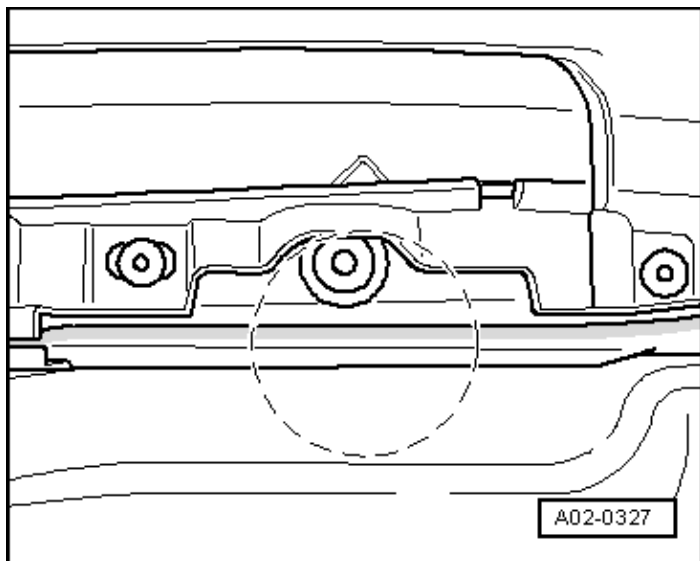

Rear: At the side member vertical reinforcement area.
Marking is for the onboard vehicle jack.

ENGINE MECHANICAL – 2.0L CAED, CPMB

General, Technical Data – 2.0L CAED, CPMB

Engine Number Location

The engine number (engine code and serial number) is located at the front of the engine/transmission joint. In addition, a sticker with the engine code and serial number is affixed to the toothed belt guard.

The engine code is also included on the vehicle data plates.

Engine Data

Code letters		CAED, CPMB
Displacement	liter	1.984
Output	kW at RPM	155/6000
Torque	Nm at RPM	350/1500
Bore	diameter mm	82.5
Stroke	mm	92.8
Compression ratio		9.6
Research Octane Number (RON)		95 ¹⁾
Injection system/ignition system		FSI
Ignition sequence		1-3-4-2
Knock control		Yes
Turbocharger		Yes
Exhaust Gas Recirculation (EGR)		No
Variable intake manifold		No
Variable valve timing		Yes
Secondary Air Injection (AIR)		No

¹⁾ Unleaded RON 91 is also permitted, but performance is reduced.

Engine Assembly – 2.0L CAED, CPMB

Fastener Tightening Specifications

Component	Bolt Size	Nm
Bolts and nuts	M6	9
	M8	20
	M10	40
	M12	60
Bracket for the hydraulic line, nut	-	9
Engine mount (always replace)	-	90 plus an additional 90° (¼ turn)
Engine support	-	40
Heat shield	-	10
Retaining plate for the engine mount	-	20
Subframe	-	65

Securing Engine to Transmission

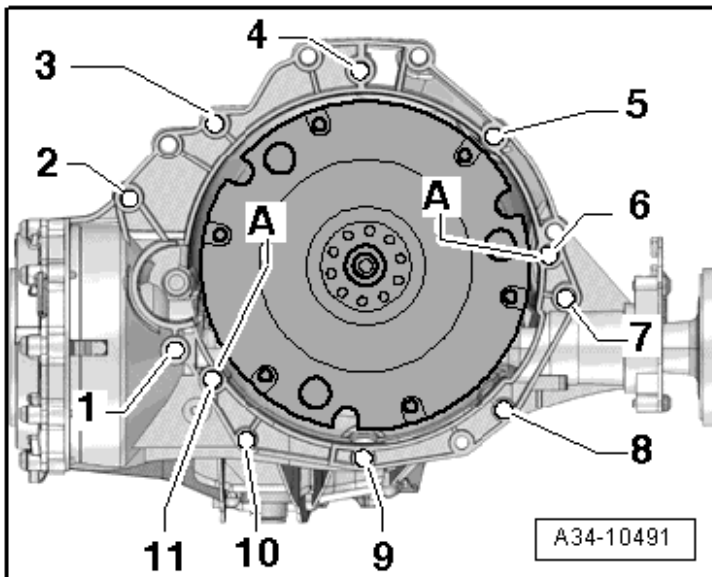

Item	Bolt	Nm
1 ¹⁾	M10 x 50 ²⁾	65
2 ¹⁾ , 7	M12 x 100 ³⁾	30 plus an additional 90° (¼ turn)
3 ⁴⁾ , 6	M12 x 75 ³⁾	30 plus an additional 90° (¼ turn)

Item	Bolt	Nm
4, 5 ⁴⁾	M12 x 120 ³⁾	15 plus an additional 90° (¼ turn)
8, 10	M10 x 75 ³⁾	15 plus an additional 90° (¼ turn)
11 ⁵⁾	M12 x 50 ³⁾	30 plus an additional 90° (¼ turn)
A	Alignment sleeves for centering	

¹⁾ Also secures the starter.

²⁾ Bolt strength rating 10.9, there is no limit to the number of times steel bolts can be used.

³⁾ Replace bolts.

⁴⁾ With a bracket for the wires.

⁵⁾ Installed from the engine side.

Aluminum bolts 2 through 11 can only be used twice. After using the bolts once, use a chisel and mark the bolts with two notches (X). To prevent damaging the bolts when marking them, do not clamp them in a vise. Use a ½" drive 14 mm socket and extension clamped into a vice. Do not use bolts that have been marked with an X.

Crankshaft, Cylinder Block – 2.0L CAED, CPMB

Fastener Tightening Specifications

Component	Nm
Balance shaft bolt (intake side) bolt (always replace)	9
Connecting rod bearing cap (always replace) ¹⁾	45 plus an additional 90° (¼ turn)
Drive plate bolt (always replace)	60 plus an additional 90° (¼ turn)
Idler roller	20
Pressure relief valve	27
Pipe for balance shaft bolt (always replace)	9
Ribbed belt tensioning damper to auxiliary components bracket bolt 1	8 plus an additional 45° (⅛ turn)
Ribbed belt tensioning damper	40
Sensor wheel (always replace)	10 plus an additional 90° (¼ turn)
Vibration damper (always replace)	150 plus an additional 90° (¼ turn)

¹⁾Lubricate the thread and contact surface.

Accessory Assembly Bracket with Hydraulic Power Steering Tightening Specifications

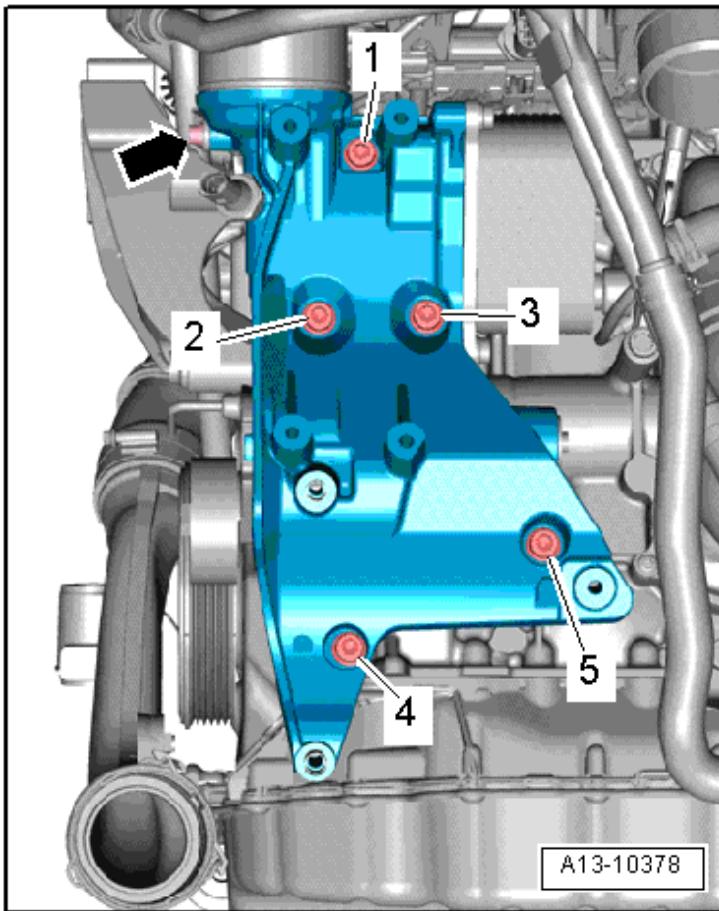

Step	Component	Nm
1	Tighten bolts 1 through 5 in sequence	Hand-tighten
2	Tighten bolts 1 through 5 in sequence	20
3	Tighten bolts 1 through 5 in sequence	an additional 90° (¼ turn)

Accessory Assembly Bracket with Electro-Mechanical Power Steering Tightening Specifications

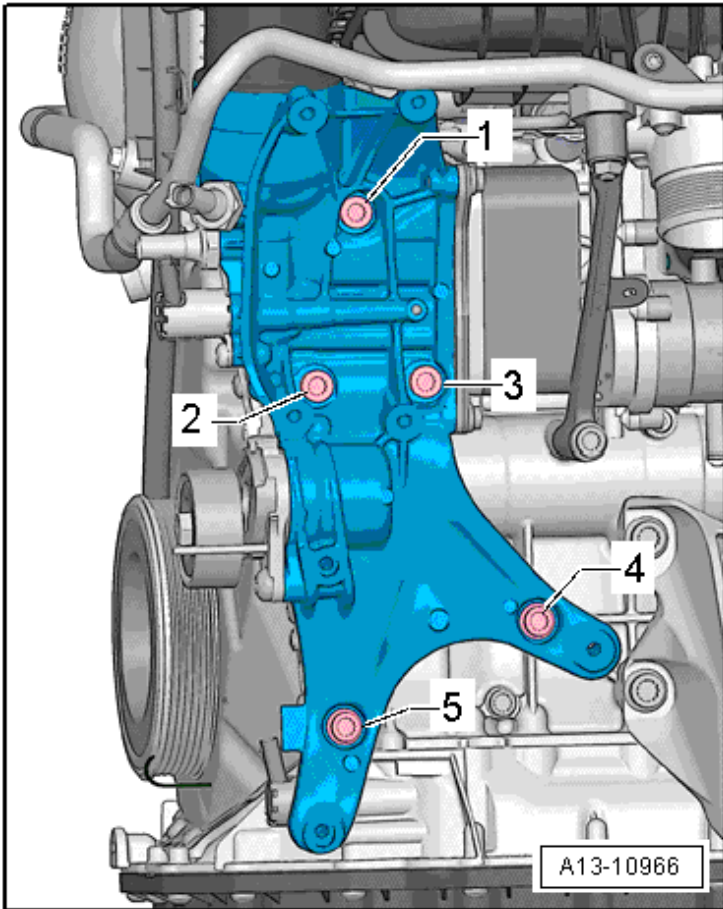

Step	Component	Nm
1	Tighten bolts 1 through 5 in sequence	Hand-tighten
2	Tighten bolts 1 through 5 in sequence	20
3	Tighten bolts 1 through 5 in sequence	an additional 90° (¼ turn)

Transmission Side Sealing Flange - Tightening Sequence, with 8 Bolts Specifications

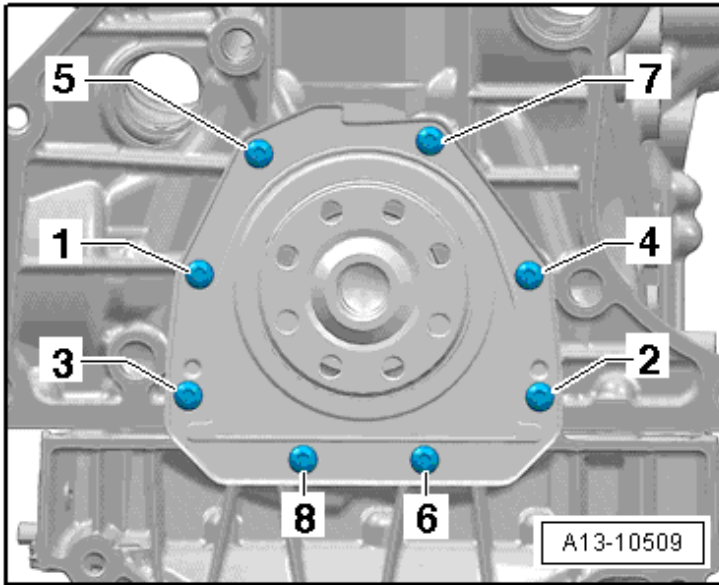

Step	Component	Nm
1	Tighten bolts 1 through 8 in sequence	Hand-tighten
2	Tighten bolts 1 through 8 in sequence	9

Transmission Side Sealing Flange - Tightening Sequence, with 6 Bolts Specifications

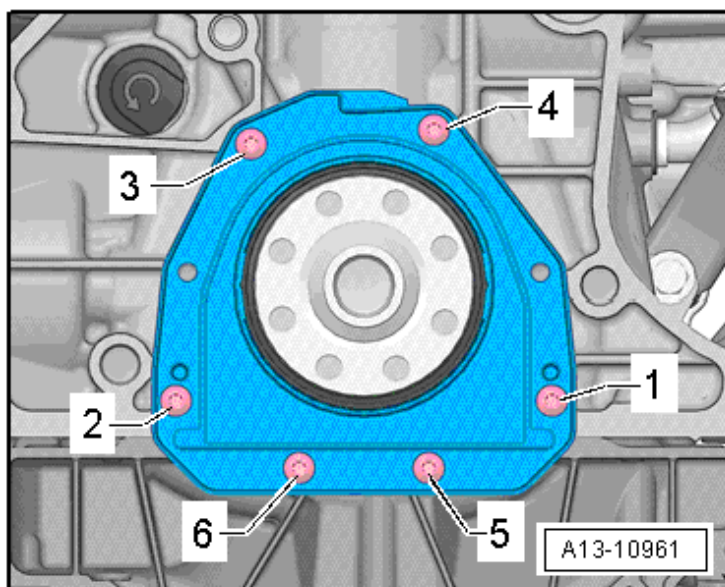

Step	Component	Nm
1	Tighten bolts 1 through 6 in sequence	Hand-tighten
2	Tighten bolts 1 through 6 in sequence	4 an additional 45° (1/8 turn)

Cylinder Block Bearing Shell Identification

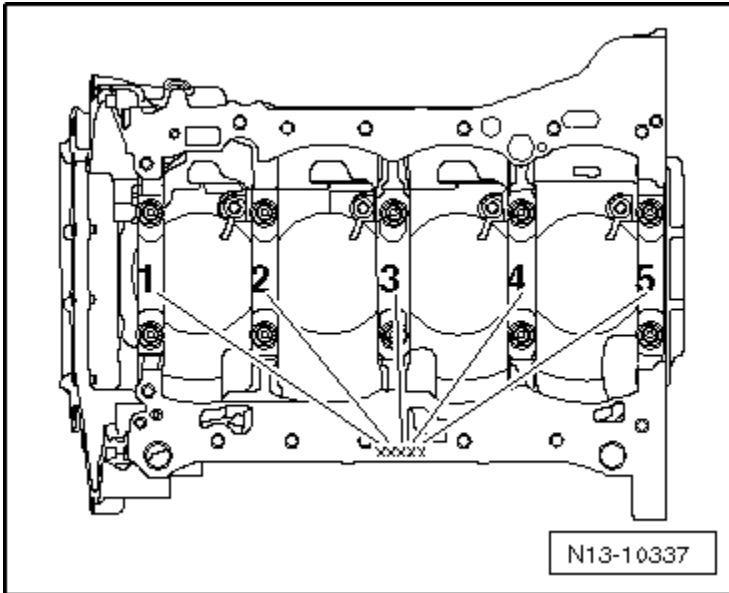

The cylinder block bearing shell identification is located either on the oil pan sealing surface or on the top (transmission side) of the cylinder block.

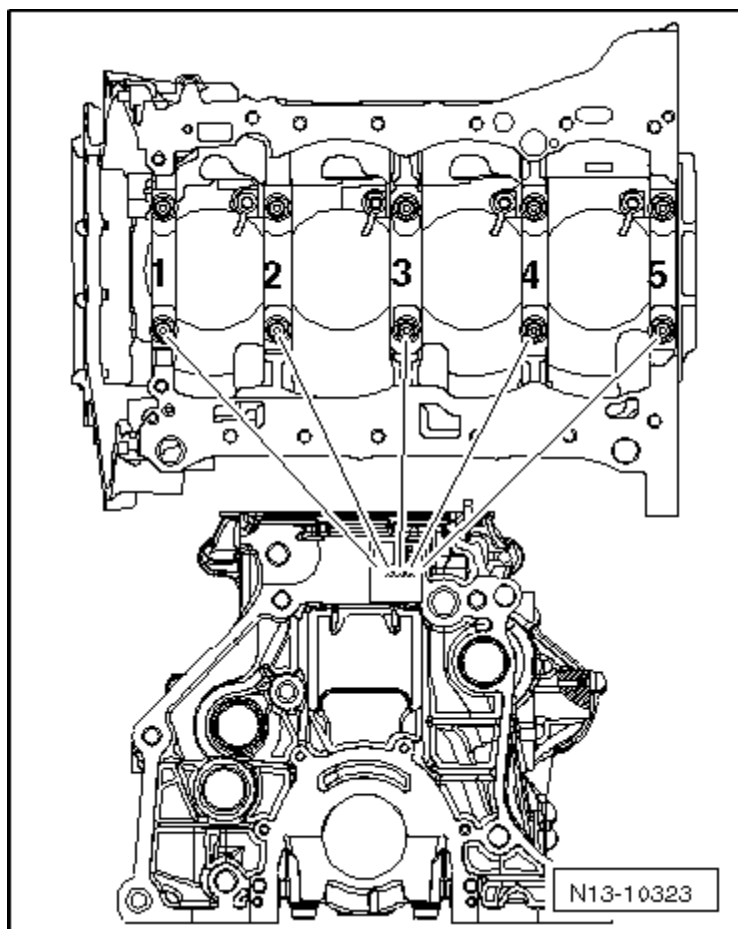

The identification on the cylinder block is for the upper bearing shell.
Note the letter and match it to the color identification
in the table.

Bearing Cap Bearing Shell Identification

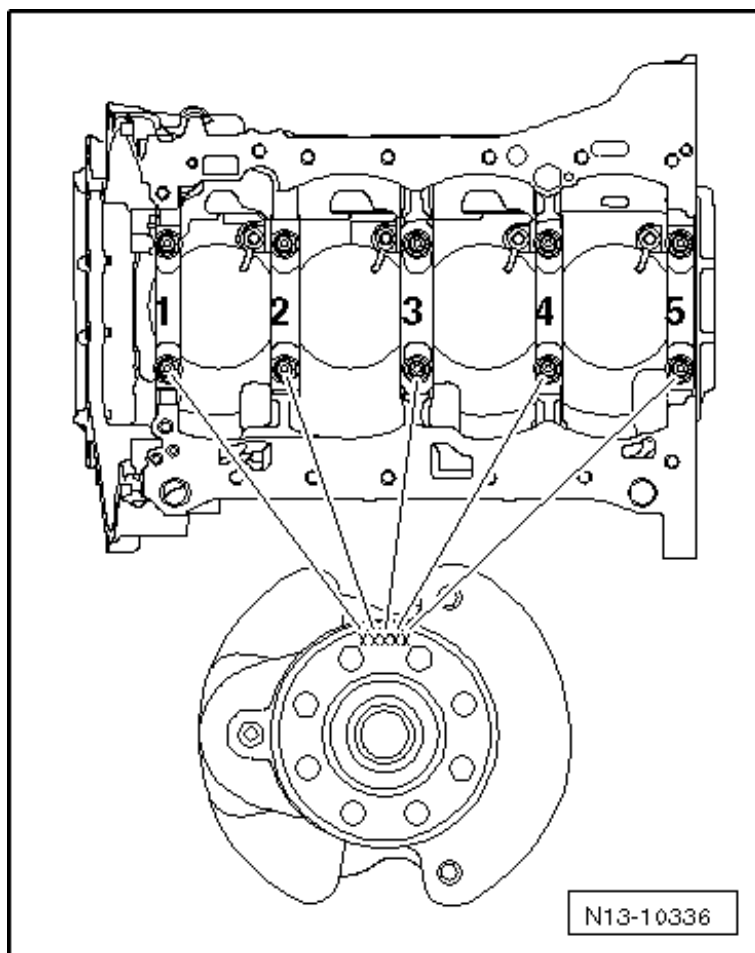

The identification on the crankshaft is for the lower bearing shell. Note the letter and match it to the color identification in the table.

Letter on crankshaft	Color of bearing
S	Black
R	Red
G	Yellow
B	Blue
W	White

Piston Ring End Gaps

Piston ring Dimensions in mm	New	Wear limit
Compression ring	0.20 to 0.40	0.80
Oil scraping ring	0.25 to 0.50	0.80

Piston Ring Clearance

Piston Ring Dimensions in mm	New	Wear Limit
1 st compression ring	0.06 to 0.09	0.20
2 nd compression ring	0.03 to 0.06	0.15
Oil scraping rings	Cannot be measured	

Piston and Cylinder Dimensions

Honing dimension		Piston diameter	Cylinder bore diameter
Basic dimension	mm	82.465 ¹⁾	82.51

¹⁾ Measurements without graphite coating (thickness 0.02 mm). The graphite coating wears away.

Piston and Connecting Rod Tightening Specifications

Component	Nm
Connecting rod bearing cap bolts	45 plus an additional 90° (¼ turn)
Pressure relief valve-to-oil spray jet	27

Crankshaft Dimensions

Reconditioning Dimension ¹⁾		Crankshaft Bearing Pin Diameter	Connecting Rod Bearing Pin Diameter
Basic dimension	mm	58.00	47.80

¹⁾ The preparation of worn crankshafts is not provided.

Crankshaft Assembly Tightening Specifications

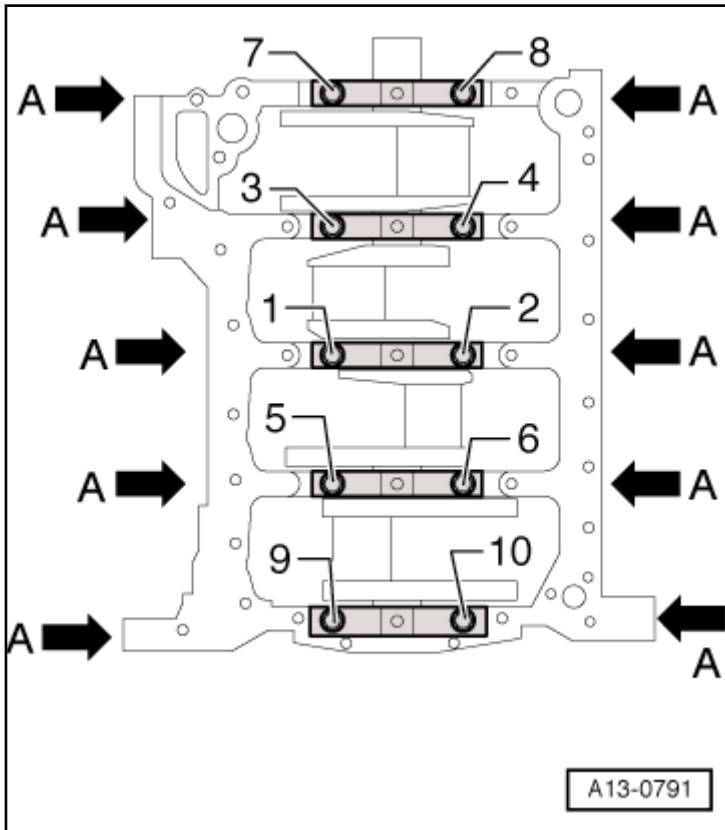

Step	Component	Nm
1	Tighten bolts 1 through 10 and A ➡ in sequence	Hand-tighten
2	Tighten bolts 1 through 10 in sequence	65
3	Tighten bolts 1 through 10 in sequence ¹⁾	an additional 90° (¼ turn)
4	Tighten bolts A ➡	20
5	Tighten bolts A ➡ ¹⁾	an additional 90° (¼ turn)

¹⁾ Use a rigid wrench

Cylinder Head, Valvetrain – 2.0L CAED, CPMB

Fastener Tightening Specifications

Component	Nm
Bearing bracket camshaft housing bolt	9
	20 plus an additional 90° (¼ turn) ²⁾
Cam adjustment actuator bolt	5
Camshaft position sensor bolt	9
Camshaft timing chain guide rail guide pin	20
Chain tensioner	85
Chain tensioner to timing chain tensioning rail bolt	9
Glide track guide pin	20
Glide track guide pin (for timing chain)	20
Oil dipstick guide tube	9
Tensioning rail guide pin (for balance shaft drive chain)	20
Timing chain tensioning rail guide pin	20
Cylinder Head Overview, Engine with Wrench Clearance	
Cam adjustment actuator bolt	5
Cylinder head bolt tighten in 3 steps: ^{2) 4)}	
- Tighten to	40
- Tighten 90° further using a rigid wrench.	-
- Tighten 90° further using a rigid wrench.	-
Cylinder head bolt tighten in 2 steps: ³⁾	
- Tighten to	8
- Tighten 90° further using a rigid wrench.	-
Heat shield to cylinder head bolt	20
Plug with ball head for the engine cover	5
Retaining plate to connection	9
Transport strap bolt	25

Cylinder Head Overview, Engine without Wrench Clearance	
Cam adjustment actuator bolt	5
Camshaft position sensor bolt	9
Heat shield to cylinder head bolt	20
Plug with ball head for the engine cover	5
Retaining plate to connection bolt	9
Transport strap bolt	25

¹⁾ For bolt tightening clarification, refer to *Elsaweb*, "Camshaft Timing Chain Overview" see items 5 and 7.

²⁾ Always replace.

³⁾ For bolt tightening clarification, refer to *Elsaweb* "Cylinder Head Overview, Engine with Wrench Clearance" see item 4.

⁴⁾ For bolt tightening clarification, refer to *Elsaweb* "Cylinder Head Overview, Engine with Wrench Clearance" see item 6

Cylinder Head, with Wrench Access – Removal Sequence

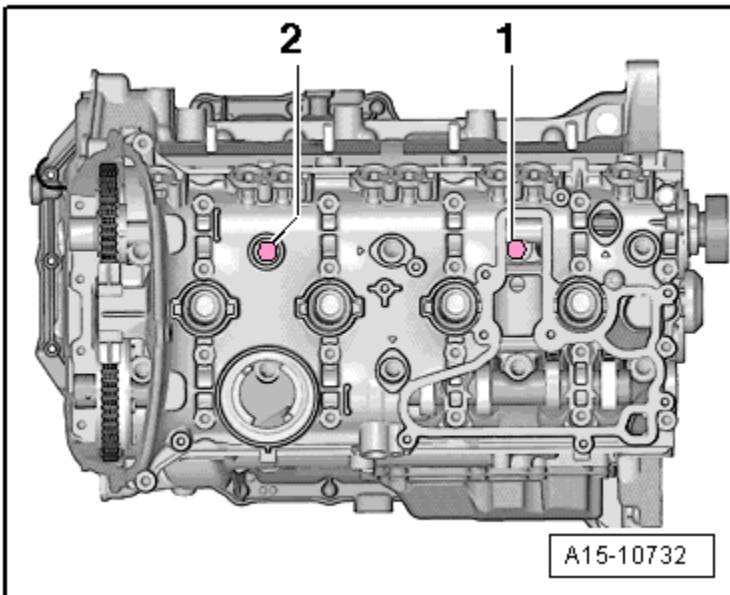

Remove cylinder head bolts 1 and 2 in sequence.

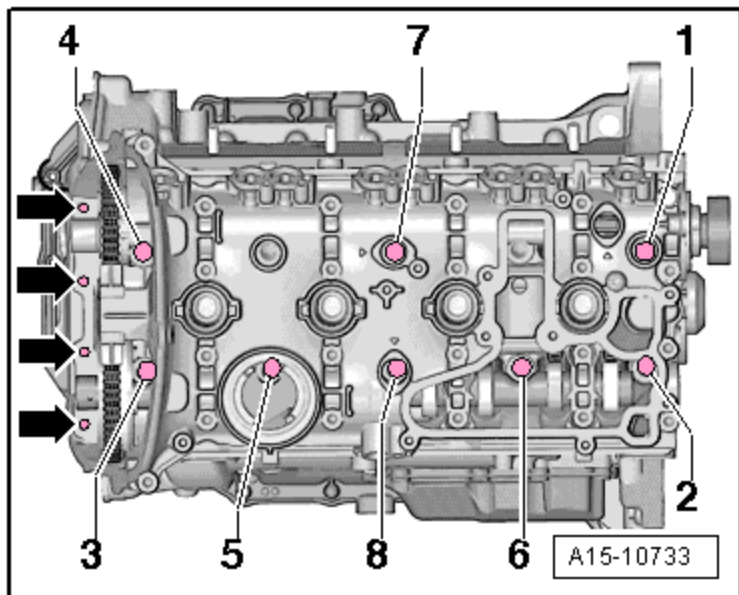

Remove cylinder head bolts 1 through 8 in sequence.

Cylinder Head, without Wrench Access – Removal Sequence

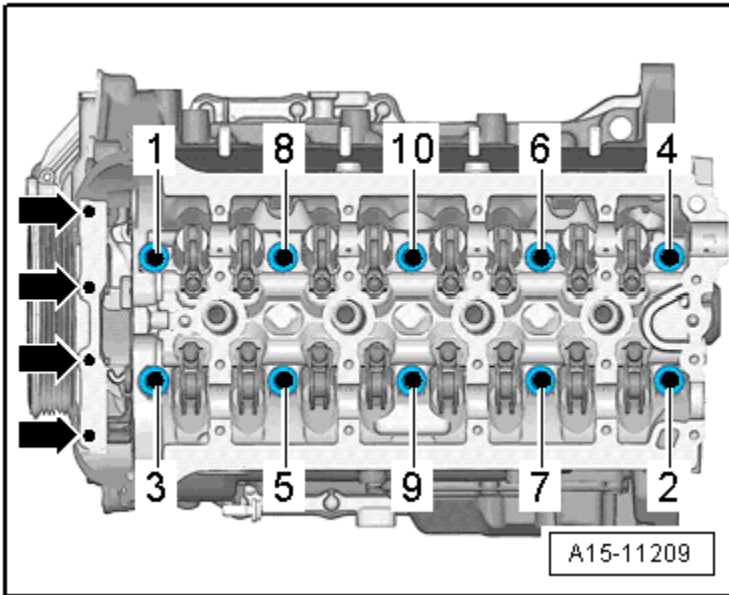

Step	Component
1	Remove bolts ➡
2	Remove bolts 1 and 10 in sequence

Cylinder Head, with Wrench Access – Tightening Specifications

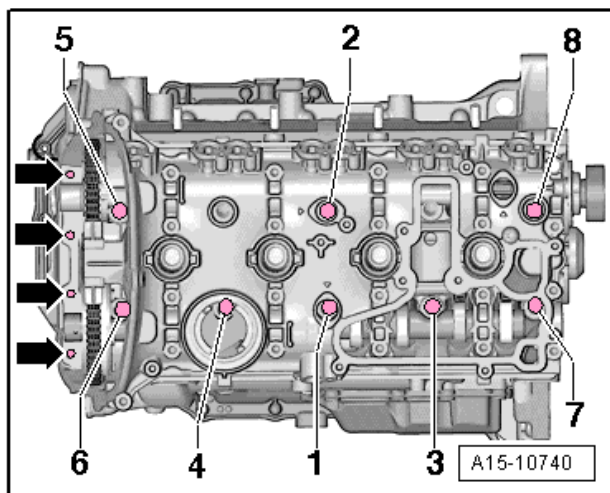

Step	Component	Nm
1	Tighten bolts 1 through 8 in sequence	40
2	Tighten bolts 1 through 8 in sequence	an additional 90° (¼ turn)
3	Tighten bolts 1 through 8 in sequence	an additional 90° (¼ turn)

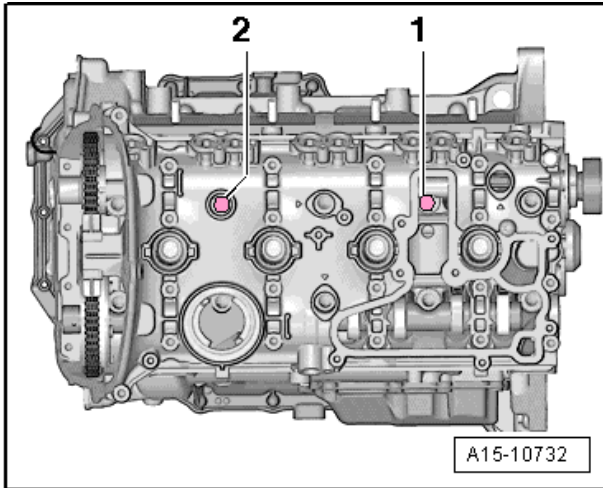

Step	Component	Nm
1	Tighten bolts 1 and 2 in sequence	40
2	Tighten bolts 1 and 2 in sequence	an additional 90° (¼ turn)
3	Tighten bolts 1 and 2 in sequence	an additional 90° (¼ turn)

Cylinder Head, without Wrench Access – Specifications

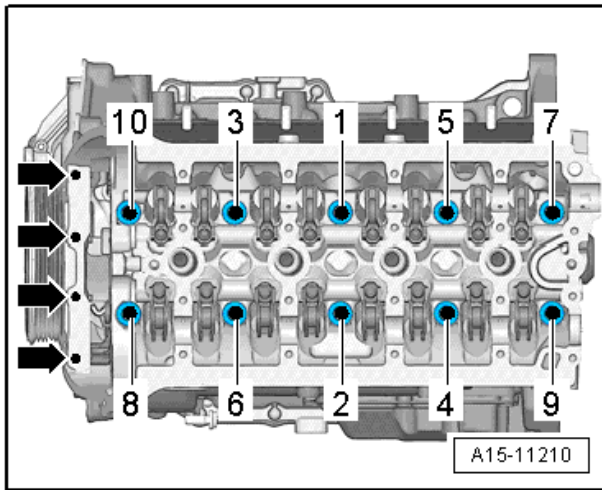

Step	Component	Nm
1	Tighten bolts 1 through 10 in sequence in several stages	40
2	Tighten bolts 1 through 10 in sequence (using a torque wrench)	an additional 90° (¼ turn)
3	Tighten bolts 1 through 10 in sequence (using a rigid wrench)	an additional 90° (¼ turn)
4	Tighten bolts ➡	8
5	Tighten bolts 1 through 10 in sequence (using a rigid wrench)	an additional 90° (¼ turn)

Cylinder Head Cover Loosening Sequence

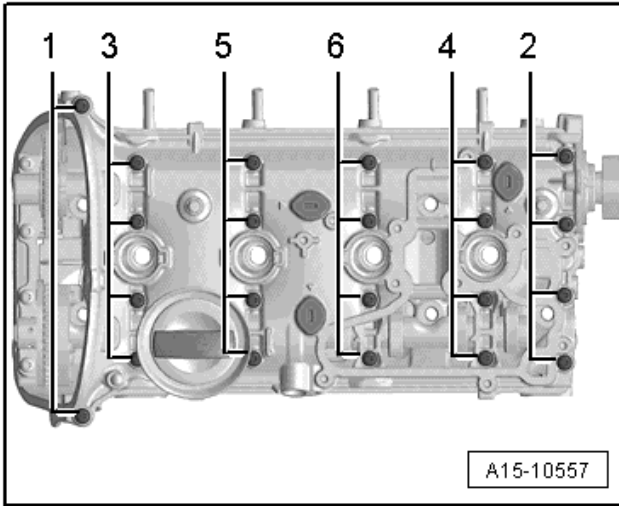

Loosen the cylinder head cover bolts 1 through 6 in sequence.

Cylinder Head Cover Tightening Specifications

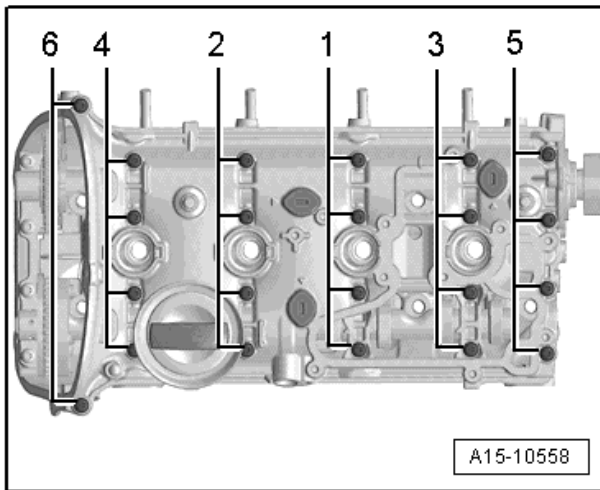

Step	Component	Nm
1	Tighten bolts 1 through 6 in sequence in several stages	Hand-tighten
2	Tighten bolts 1 through 6 in sequence	8
3	Tighten bolts 1 through 6 in sequence	an additional 90° (¼ turn)

Compression Pressures

New Bar Positive Pressure	Wear Limit Bar Positive Pressure	Difference Between Cylinders Bar Positive Pressure
11.0 to 14.0	7.0	Max. 3.0

Valve Dimensions

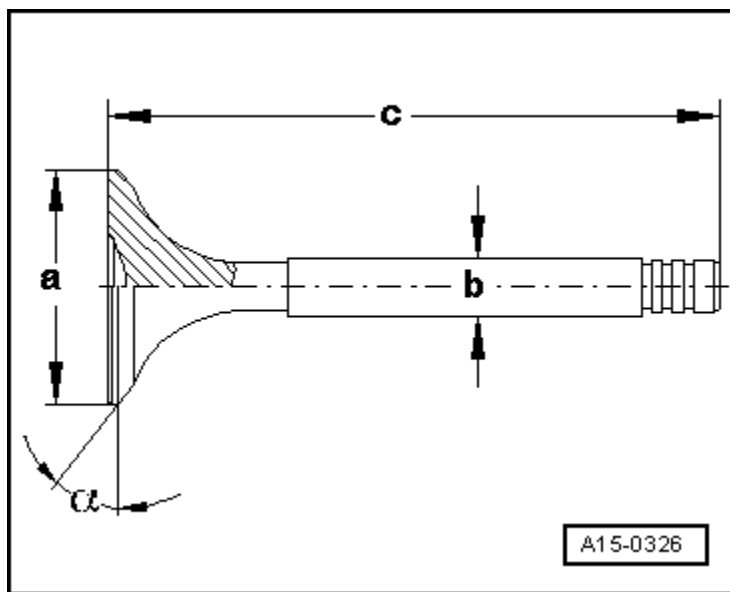

Dimension		Intake valve	Exhaust valve
Diameter a	mm	33.85 ± 0.10	28.0 ± 0.1
Diameter b	mm	5.98 ± 0.01	5.96 ± 0.01
c	mm	104.0 ± 0.2	101.9 ± 0.2
α	∠°	45	45

Intake and exhaust valves must not be refaced by grinding. Only lapping is permitted.

Upper Timing Chain Cover Tightening Specification

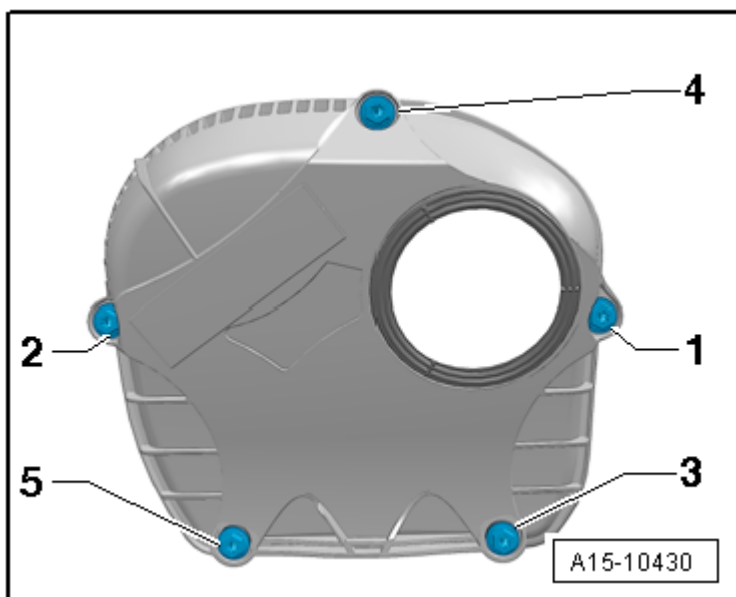

Step	Component	Nm
1	Tighten bolts 1 through 5 in sequence	9

Intermediate Sprocket Tightening Sequence

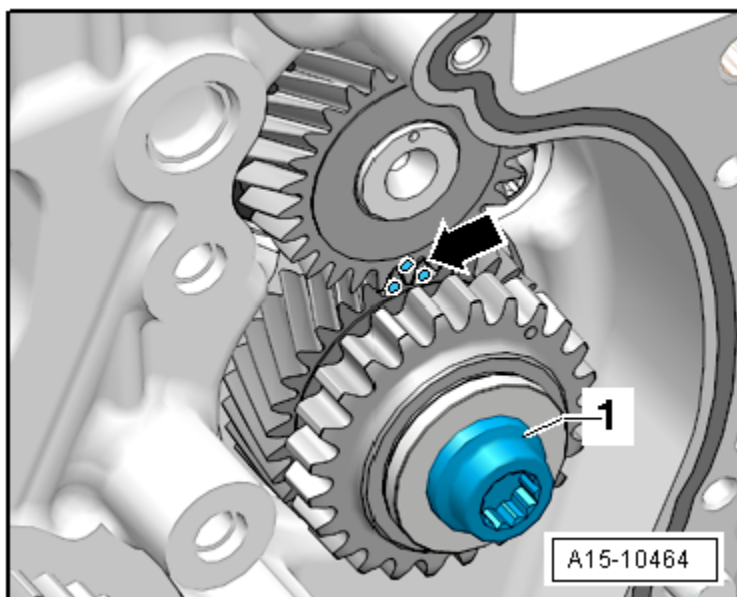

Step	Component	Nm
1	Tighten with a new bolt	
2	Tighten bolt	10
3	The intermediate sprocket must not have any play. Loosen and tighten it again if necessary.	
4	Tighten bolt (using a torque wrench)	25
5	Tighten bolt (using a rigid wrench)	an additional 90° (¼ turn)

Crankcase Ventilation, Tightening Sequence

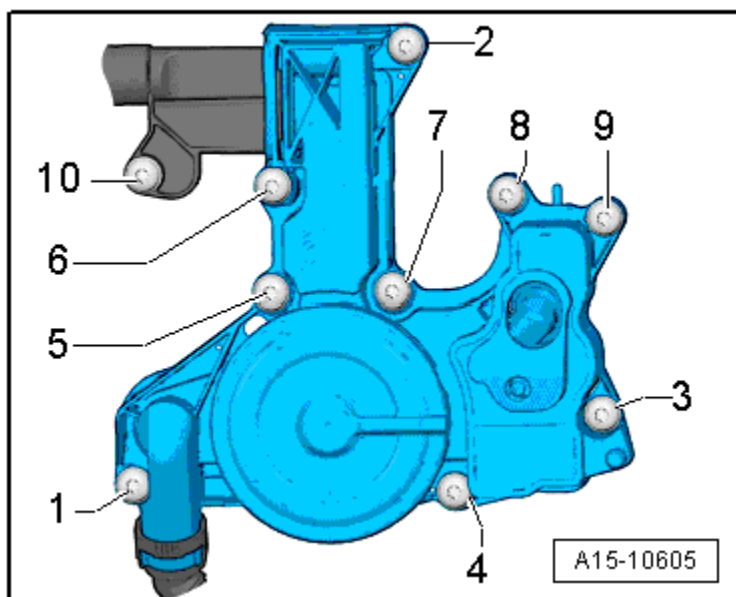

Step	Component	Nm
1	Tighten bolts 1 through 10 in sequence	11

Lower Timing Chain Cover - Tightening Sequence for 15 Bolts Specifications

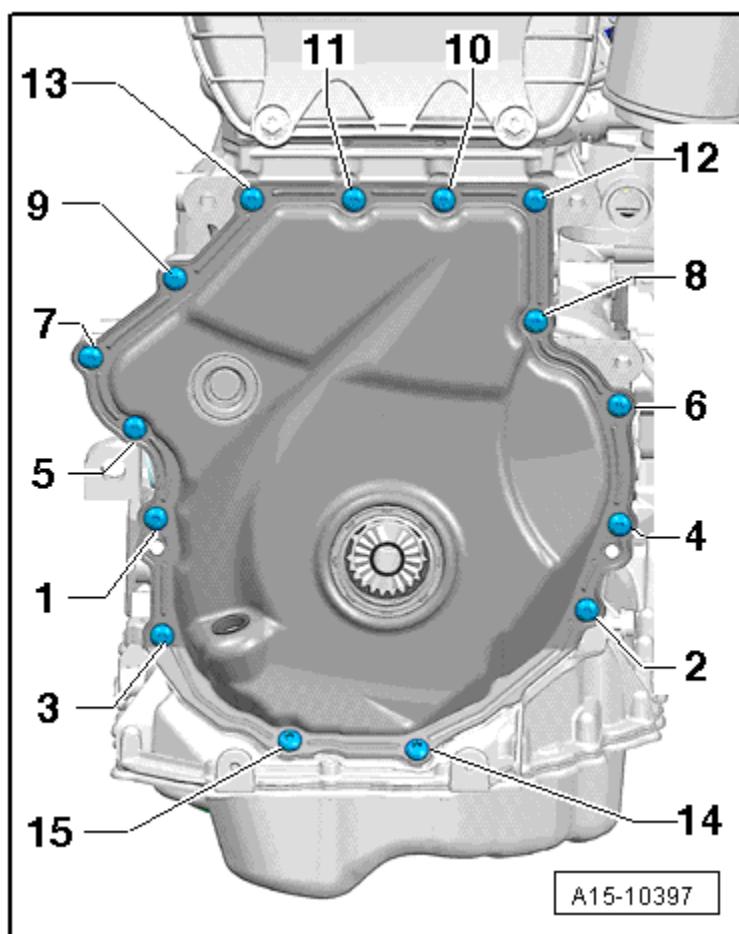

Step	Component	Nm
1	Tighten bolts 1 through 15 in sequence	8
2	Tighten bolts 1 through 15 in sequence	an additional 45° (1/8 turn)

Lower Timing Chain Guard - Tightening Sequence for 8 Bolts Specifications

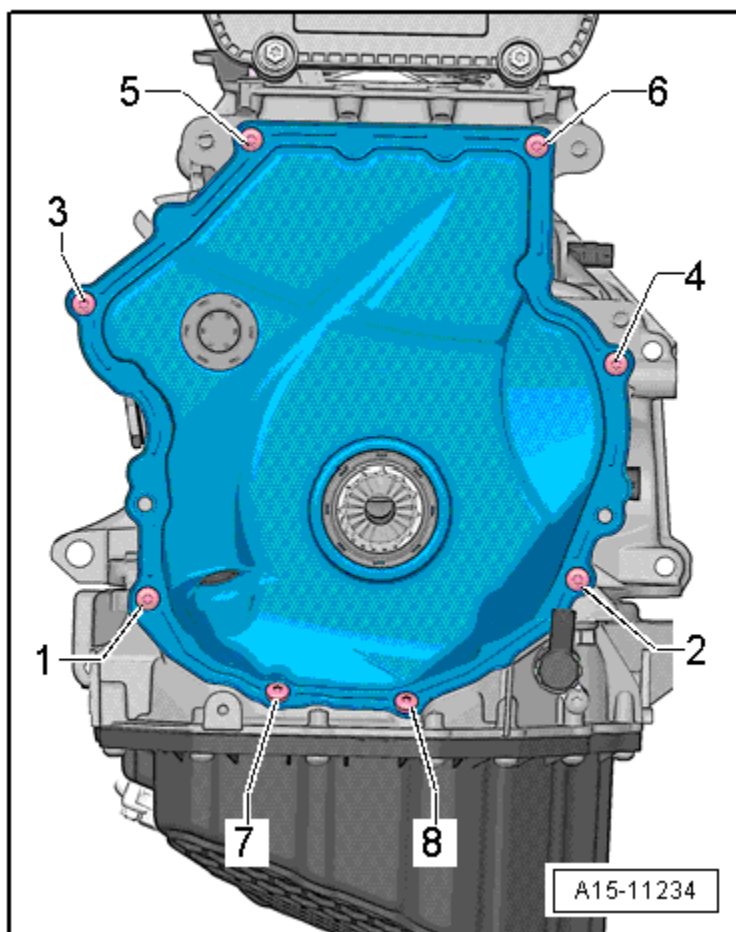

Step	Component	Nm
1	Tighten bolts 1 through 8 in sequence	4
2	Tighten bolts 1 through 8 in sequence	an additional 45° (1/8 turn)

Engine Lubrication – 2.0L CAED, CPMB

Fastener Tightening Specifications

Component	Nm
Chain tensioner to engine	9
Engine oil cooler to auxiliary components bracket	23
Intake line to oil pump bolt	9
Oil baffle to upper oil pan	9
Oil drain plug (always replace)	30
Oil level thermal sensor nut	9
Oil pump to upper oil pan bolt	20
Oil pressure regulation valve to oil pan upper section bolt	9
Oil pressure switch to auxiliary components bracket	20
Reduced oil pressure switch to auxiliary components bracket	20

Oil Pan Upper Section Tightening Specifications

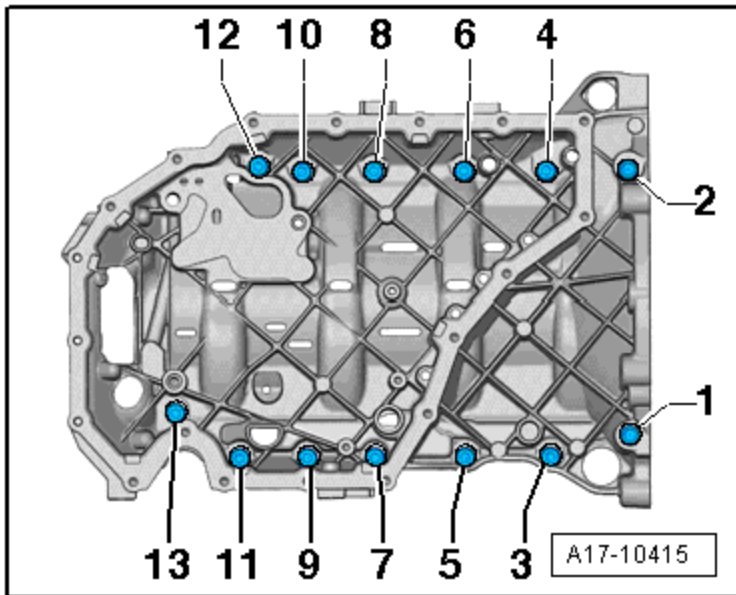

Step	Component	Nm
1	Tighten bolts 1 through 13 in sequence	15
2	Tighten bolts 1 through 13 in sequence	an additional 90° (¼ turn)

Oil Pan Tightening Specifications

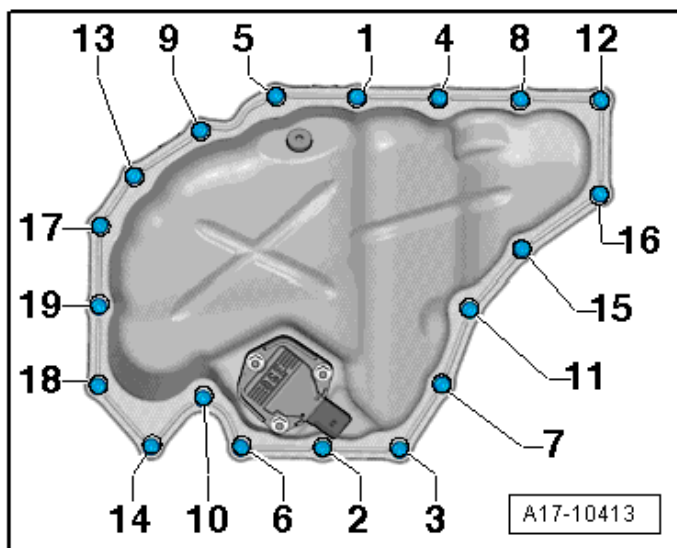

Step	Component	Nm
1	Tighten bolts 1 through 19 in sequence	8
2	Tighten bolts 1 through 19 in sequence	an additional 45° (1/8 turn)

Oil Separator Tightening Specification

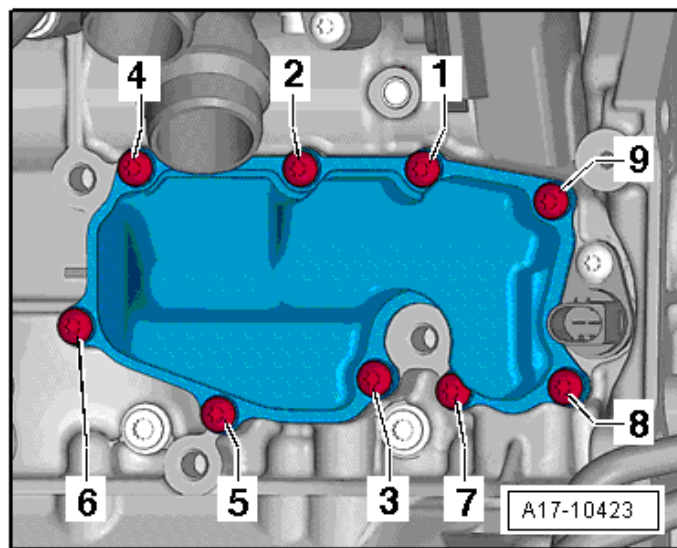

Step	Component	Nm
1	Tighten bolts 1 through 9 in sequence	9

Fuel Injection and Ignition – 2.0L CAED, CPMB

Fuel Injection System Data

Engine code	2.0L Turbo FSI Engine
Idle speed cannot be adjusted, it is regulated by idle stabilization	640 to 800 RPM
RPM limited by switching off fuel injectors and closing throttle valve	6500 RPM
Ignition timing is regulated by control module. It is not possible to adjust the ignition timing.	
Ignition System: Single coil ignition system with 4 ignition coils (output stages integrated) that are connected directly to spark plugs via the ignition cables.	
Ignition sequence	1-3-4-2
Spark plugs	Refer to the Parts Catalog

Fastener Tightening Specifications – Fuel Injection

Component	Nm
Bonded rubber bushing	10
Bracket for the connectors bolt	4
Clamp for the high pressure line	5
Connection for fuel return line ³⁾	40
Fuel line with bracket bolt	9
Fuel pressure sensor ²⁾	27
Fuel Rail bolt (engine code CAEB and CAED)	5
Fuel rail bolt (engine code CPMA and CPMB)	9
Fuel return pipe union nut ²⁾	27
High pressure line union nut ¹⁾	27
Intake air temperature sensor bolt	5
Intake manifold bolt/nut	
- Pre-tightening	3
- Final tightening	10
Intake manifold support	
- Bolt	20
- Nut	10
Intake manifold runner position sensor to intake manifold bolt	0.8
Low fuel pressure sensor	27
Oxygen Sensor	55
Throttle valve control module to intake manifold bolt	7

Component	Nm
Throttle valve control module to upper intake manifold bolt	9
Vacuum hose bolt	4

1) Coat the thread on the union nut with clean engine oil.

2) Coat the threads with clean engine oil.

3) Replace after removing

Fastener Tightening Specifications – Ignition

Component	Nm
Camshaft Position (CMP) sensor	9
Engine speed sensor	4.5
Knock Sensor (KS)	20

Engine Cooling – 2.0L CAED, CPMB

Fastener Tightening Specifications

Component	Nm
After-run coolant pump V51 clamp bracket bolt	4
Bracket	9
Connecting piece	9
Coolant Fan Control (FC) control module	2.5
Coolant hose bolt	9
Fan shroud bolt	5
Retaining plate bolt	4
Rubber buffer bolt	3.5
Small coolant pipe	6
Toothed belt drive gear (always replace)	10 plus an additional 90° (¼ turn)
Toothed belt guard	9

1) Replace

2) Coat the threads with clean engine oil.

3) Replace after removing

Coolant Pump Tightening Specifications

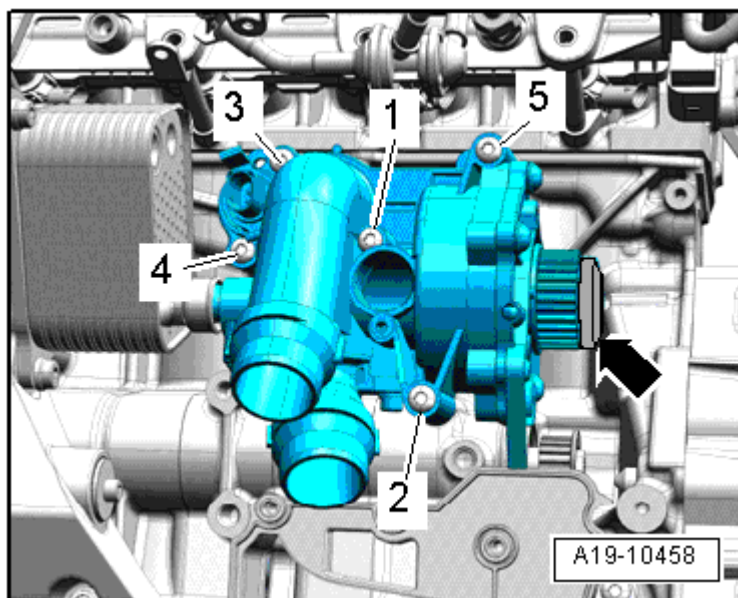

Step	Component	Nm
1	Tighten bolts 1 through 5 in sequence	9

Fuel Supply System – 2.0L CAED, CPMB Fastener Tightening Specifications

Component	Nm
Accelerator pedal module to pedal bracket bolt	8
Carrier plate to fuel tank bolt	20
EVAP canister bolt	16
Fuel filler neck to body bolt	20
Fuel pump control module bolt	2.5
Fuel tank heat shield nut	2
Locking flange cover bolt	1.5
Leak detection pump nut	5
Leak detection pump to EVAP canister bolt	4
Shield to fuel filler tube bolt	8
Union nut	120

Turbocharger – 2.0L CAED, CPMB

Fastener Tightening Specifications

Component	Nm
Air guide pipe to bracket	10
Bracket bolt	30
Charge air cooler bolt	7
Charge air pressure sensor bolt	5
Clamping strip nut ^{3) 5)}	30
Connection to turbocharger bolt	9
Coolant supply line bolt ²⁾	9
	35
Crankcase ventilation line to turbocharger bolt	9
Oil return line bolt	9
Oil supply line to turbocharger bolt ¹⁾	9
	30
Hose clamp	5.5
Right air guide pipe to the oil pan	10
Rubber grommet nut	9
Support bolt ^{3) 4)}	30
Turbocharger recirculation valve to turbocharger bolt	7
Turbocharger vacuum diaphragm to turbocharger bolt	
- Bolt	10
- Nut ⁶⁾	9
Wastegate bypass regulator valve to turbocharger bolt	3

¹⁾ For bolt tightening clarification, refer to *Part II Turbocharger Overview* items 6 and 8-

²⁾ For bolt tightening clarification, refer to *Part II Turbocharger Overview* and see items -12, 13 and 14-

³⁾ Coat the bolt with hot bolt paste; Refer to the Parts Catalog

⁴⁾ For bolt tightening clarification, refer to *Part III Turbocharger Overview* and see items -11 and 12 -

⁵⁾ Replace

⁶⁾ Secure with sealing wax; Refer to the Parts Catalog

Turbocharger Tightening Specifications

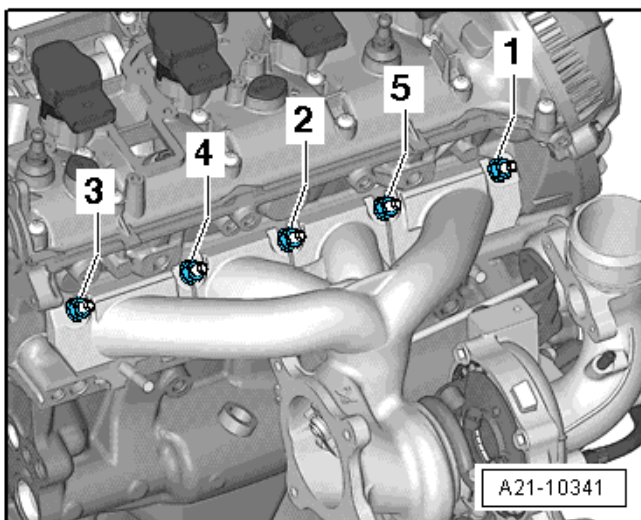

Step	Component	Nm
1	Tighten bolts 1 through 5 in sequence	5
2	Tighten bolts 1 through 5 in sequence	12
3	Tighten bolts 1 through 5 in sequence	16
4	Tighten bolts 1 through 5 in sequence	25

Exhaust System – 2.0L CAED, CPMB

Fastener Tightening Specifications

Component	Nm
Bracket for retaining loop	23
Catalytic converter, nuts (always replace)	25
	40 ¹⁾
Exhaust tailpipe clamp	60
Front clamping sleeve, nut	25
Rear clamping sleeve, nut	25
Suspended mount (always replace)	23

¹⁾ Replace

²⁾ For bolt tightening clarification, refer to *Muffler Overview, Vehicles with a Rear Muffler* items 10 and 12

³⁾ For bolt tightening clarification, refer to *Muffler Overview, Vehicles with two Rear Mufflers* items 21 and 22

⁴⁾ Coat turbocharger stud bolts with hot bolt paste.

ENGINE MECHANICAL – 3.0L CGXC, CTUB

General, Technical Data – 3.0L CGXC, CTUB

Engine Number Location

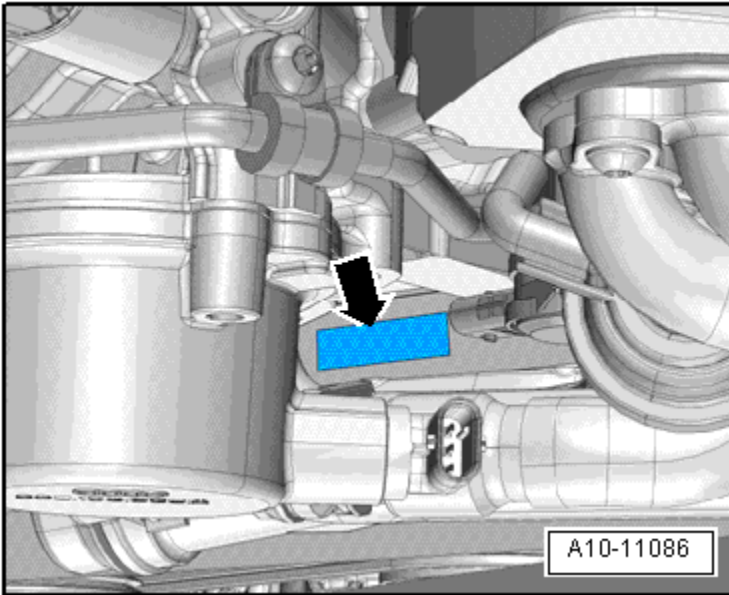

The engine number (engine code and serial number) is located on the top front of the cylinder block, below the right cylinder head ➔. Engine codes beginning with C are four-digit. The first 3 digits of the engine code indicate the displacement and the mechanical structure of the engine. They are stamped in the cylinder block including the serial number. The fourth digit describes the engine output and torque and depends on the engine control module.

Engine Data

Code letters		CGXC
Displacement	liter	2.995
Output	kW at RPM	245/5500 to 7000
Torque	Nm at RPM	440/2900 to 5300
Bore	diameter mm	84.5
Stroke	mm	89.0
Compression ratio		10.5
RON	at least	98 ¹⁾

Engine Data (cont'd)

Code letters	CGXC
Fuel injection and ignition system	Simos
Ignition sequence	1-4-3-6-2-5
Exhaust Gas Recirculation (EGR)	No
Supercharger	Supercharger
Knock Sensor (KS)	2 sensors
Charge Air Cooler (CAC)	Yes
Oxygen Sensor (O2S) regulation	2 sensors before catalytic converter 2 sensors after catalytic converter
Variable valve timing	Intake
Variable intake manifold	No
Secondary Air Injection (AIR) system	Yes
Valve per cylinder	4

¹⁾ Regular unleaded RON 91 is permitted although with reduced engine power.

Engine Assembly – 3.0L CGXC

Fastener Tightening Specifications

Component	Bolt Size	Nm
Bolts and nuts	M6	9
	M7	15
	M8	20
	M10	40
	M12	65
Engine mount (always replace)	-	90 plus an additional 90° (¼ turn)
Engine support	-	40
Ground bolt-to-strut tower	-	9
Ground wires-to-longitudinal member	-	9
Heat shield	-	10
Hydraulic oil hose bracket	-	9
Mounting plate	-	20
Subframe	-	55

Engine to Manual Transmission Fastener Tightening Specifications

Engine –
3.0L CGXC, CTUB

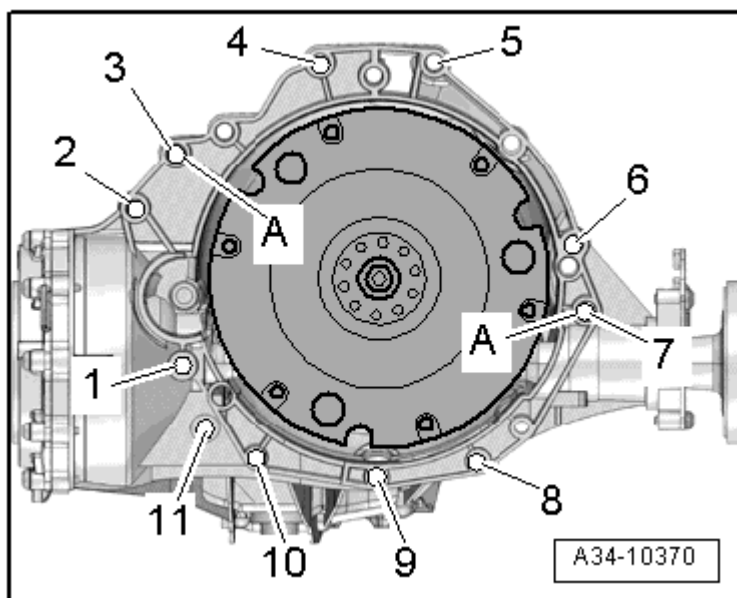

Component	Bolt Size	Nm
1	M10 x 50 ¹⁾	65
2 through 6	M12 x 100 ²⁾	30 plus an additional 90° (¼ turn)
7	M12 x 125 ²⁾	30 plus an additional 90° (¼ turn)
8, 11	M10 x 60 ²⁾	15 plus an additional 90° (¼ turn)
9, 10	M10 x 95 ²⁾	15 plus an additional 90° (¼ turn)
A	Alignment sleeves for centering	
¹⁾ Bolt class 10.9, the steel bolt may be used again unlimited number of times. ²⁾ The aluminum bolts can be used 2 times.		

Engine to S tronic Transmission 0B5 Fastener Tightening Specifications

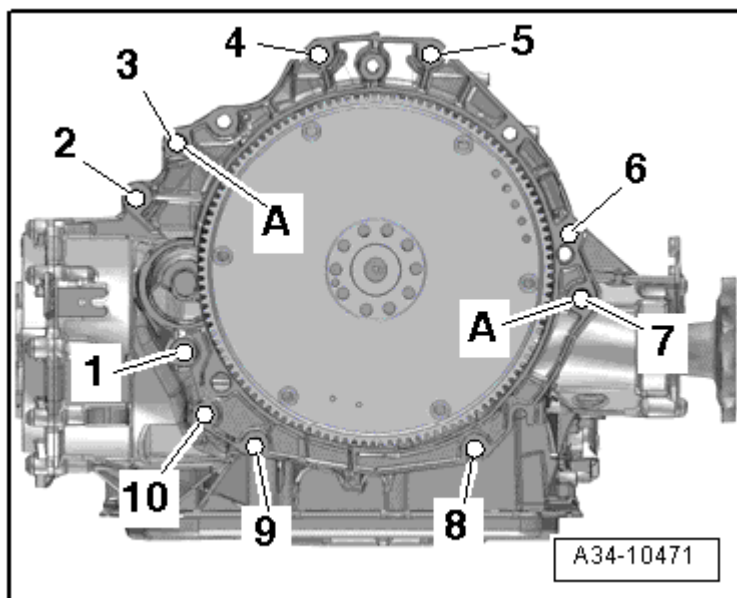

Component	Bolt Size	Nm
1	M10 x 50 ¹⁾	65
2 through 6	M12 x 100 ²⁾	30 plus an additional 90° (¼ turn)
7	M12 x 125 ²⁾	30 plus an additional 90° (¼ turn)
8	M10 x 60 ²⁾	15 plus an additional 90° (¼ turn)
9, 10	M10 x 95 ²⁾	15 plus an additional 90° (¼ turn)
A	Alignment sleeves for centering	
¹⁾ Bolt class 10.9, the steel bolt may be used again unlimited number of times. ²⁾ The aluminum bolts can be used 2 times.		

Crankshaft/Cylinder Block – 3.0L CGXC

Fastener Tightening Specifications

Component	Nm
Connecting rod ¹⁾	50 plus an additional 90° (¼ turn)
Drive plate ¹⁾	60 plus an additional 90° (¼ turn)
Idler roller for ribbed belt ³⁾	40
Idler roller for ribbed belt ²⁾	40
Oil spray jet for piston cooling ⁴⁾	9
Oil pressure regulation valve	9
Ribbed belt tensioning damper	40
TDC marking locking bolt	14
Vibration damper ¹⁾	20 plus an additional 90° (¼ turn)
¹⁾ Always replace ²⁾ For bolt tightening clarification, refer to ElsaWeb under <i>Ribbed Belt Drive, Vehicles with Hydraulic Power Steering Overview</i> and see item -6- ³⁾ For bolt tightening clarification, refer to ElsaWeb under <i>Supercharger Ribbed Belt Drive Overview</i> and see item -2- ⁴⁾ Insert bolt with locking compound	

Ribbed Belt Pulley Side Sealing Flange Tightening Specifications

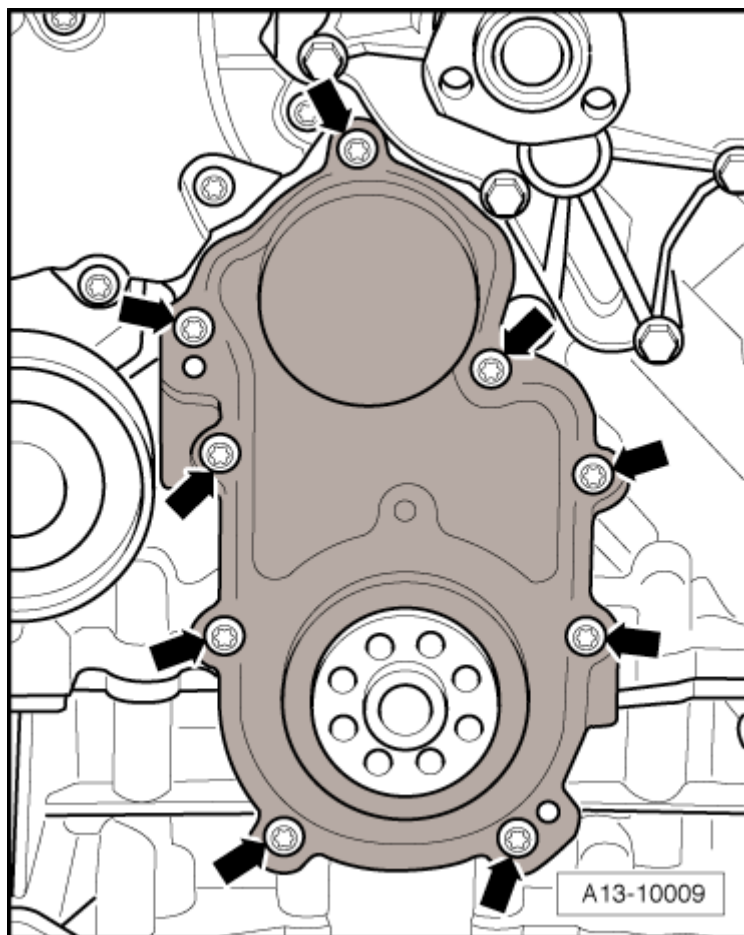

Tighten the bolts ➡ in a diagonal sequence in stages to 9 Nm.

Crankshaft Assembly Guide Frame Tightening Specifications

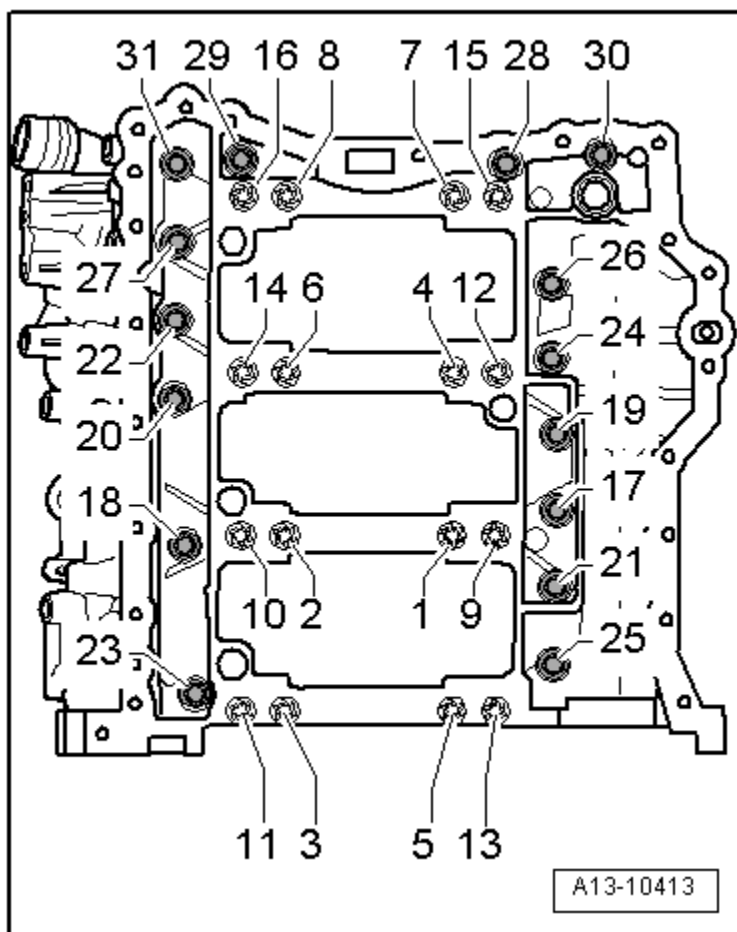

Replace bolts that are tightened to the specification. Insert the long bolts in the inner row of the guide frame. Tighten the bolts in 3 steps in the sequence shown:

Steps	Component	Nm
1	Tighten bolts 1 through 16 in the sequence	50
2	Tighten bolts 1 through 16 in the sequence	an additional 90° (¼ turn)
3	Tighten bolts 17 through 31 in sequence	23
4	Tighten bolts 17 through 31 in sequence	an additional 90° (¼ turn)

Crankshaft Dimensions

Honing dimension In mm	Crankshaft bearing pins-diameter		Crankshaft connecting rod journal- diameter	
Basic dimension	65.000	- 0.022	56.000	- 0.022
		- 0.042		- 0.042

Crankshaft Axial Play

Component	mm
Axial clearance	0.15 to 0.25

Crankshaft Radial Play

Component	mm
Radial clearance new	0.015 to 0.055
Radial clearance wear limit	0.080

Connecting Rod Radial Clearance

Component	mm
New	0.010 to 0.052
Wear limit	0.120

Piston Ring End Gap Dimensions

Honing dimension in mm	Piston Diameter	Cylinder Bore Diameter
1st Compression ring	0.20 to 0.30	0.80
2nd Compression ring	0.50 to 0.70	0.80
Oil scraping ring	0.25 to 0.50	- ¹⁾

¹⁾ Not determined yet.

Piston Ring Side Clearance Dimensions

Honing dimension in mm	Piston Diameter	Cylinder Bore Diameter
1st Compression ring	0.04 to 0.08	0.20
2nd Compression ring	0.03 to 0.07	0.20
Oil scraping ring	0.02 to 0.06	0.15

Piston and Cylinder Dimensions

Honing dimension in mm	Piston Diameter	Cylinder Bore Diameter
Basic dimension	84.49 ¹⁾	84.51

¹⁾ Measurements without graphite coating (thickness 0.02 mm). The graphite coating wears away.

Cylinder Head, Valvetrain – 3.0L CGXC

Fastener Tightening Specifications

Component	Nm
Balance shaft belt pulley side	60
Balance shaft chain sprocket ¹⁾	15 plus an additional 90° (¼ turn)
Balance shaft transmission side	60
Camshaft adjuster for intake camshaft ¹⁾	80 plus an additional 90° (¼ turn)
Camshaft adjustment solenoid valve	5
Camshaft chain sprocket for the exhaust camshaft ¹⁾	80 plus an additional 90° (¼ turn)
Chain tensioner ²⁾	9
Chain tensioner with glide track ¹⁾³⁾	10 plus an additional 45° (½ turn)
Drive chain sprocket bearing plate	8 plus an additional 45° (½ turn)
Drive sprocket for oil pump ¹⁾	30 plus an additional 90° (¼ turn)
Drive sprocket pivot pin (left) ¹⁾	5 plus an additional 60° (½ turn)
Drive sprocket pivot pin (right) ¹⁾	30 plus an additional 60° (½ turn)
Gear carrier	13
Guide rail ¹⁾	10 plus an additional 90° (¼ turn)
Left camshaft timing chain tensioner	9
Oil dipstick guide tube	9
Right camshaft timing chain tensioner	9

¹⁾ Always replace.

²⁾ For bolt tightening clarification, refer to ElsaWeb under *Timing Mechanism Drive Chain Overview and see items -7-*.

³⁾ For bolt tightening clarification, refer to ElsaWeb under *Power Take-Off Drive Chain Overview* and see items -8-

Valve Dimensions

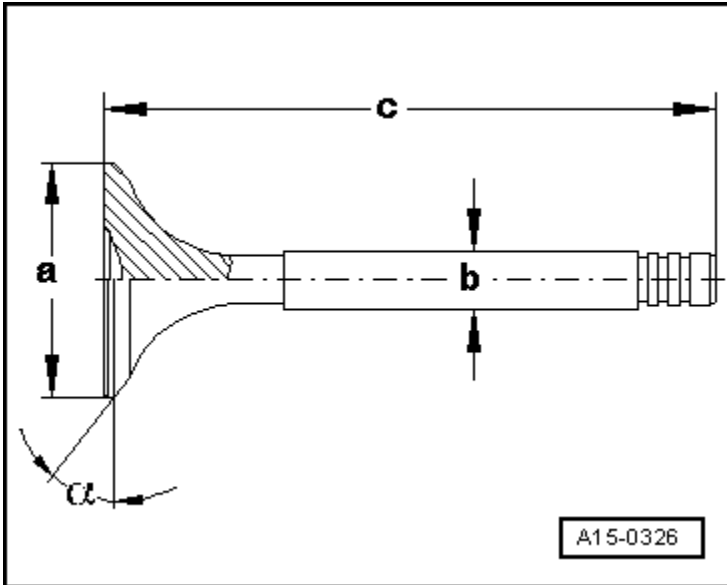

Dimension		Intake Valve	Exhaust Valve
Diameter a	mm	33.85 ± 0.10	28.0 ± 0.1
Diameter b	mm	5.98 ± 0.01	5.96 ± 0.01
c	mm	104.0 ± 0.2	101.9 ± 0.2
α	$^{\circ}$	45	45

Intake and exhaust valves must not be refaced by grinding. Only lapping is permitted.

Compression Pressures

Compression pressure	Bar pressure
New	11.0 to 14.0
Wear limit	10.0
Difference between cylinders	Max. 3.0

Cylinder Head Tightening Specifications

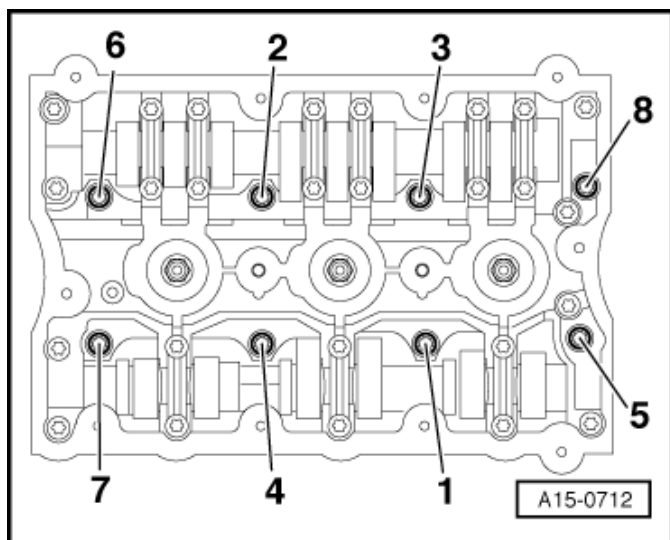

Step	Component	Nm
1	Install bolts by hand	Hand-tighten
2	Tighten bolts 1 through 8 in sequence	40
3	Tighten bolts 1 through 8 in sequence	an additional 90° (¼ turn)
4	Tighten bolts 1 through 8 in sequence	an additional 90° (¼ turn)

Left Cylinder Head Cover Tightening Specification

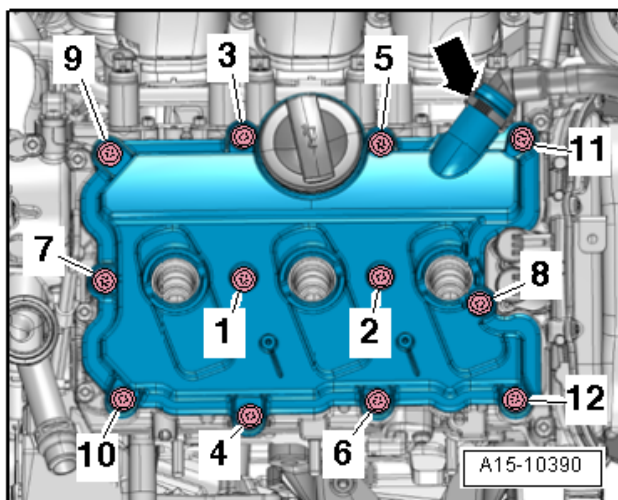

Loosen the left cylinder head cover bolts in reverse order 12 to 1.

Component	Nm
Tighten bolts 1 through 12 in sequence	9

Right Cylinder Head Cover Tightening Specification

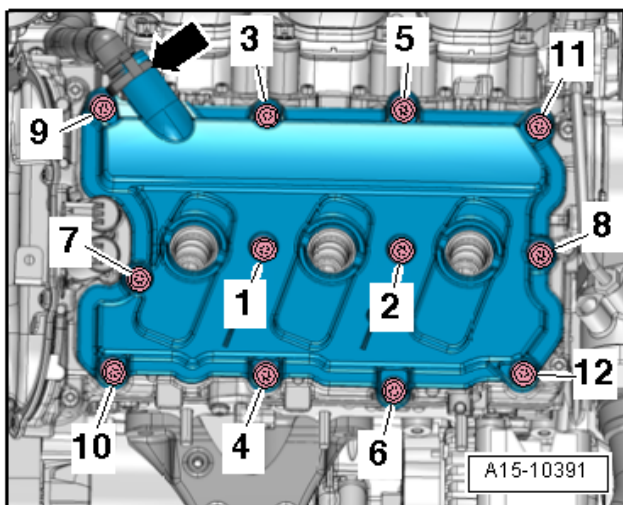

Loosen the right cylinder head cover bolts in reverse order 12 to 1.

Component	Nm
Tighten bolts 1 through 12 in sequence	9

Left Timing Chain Cover Tightening Specifications

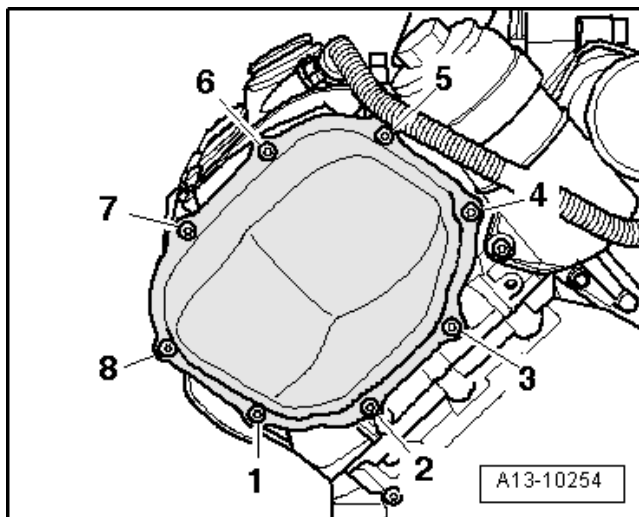

Step	Component	Nm
1	Tighten bolts 1 through 8 in sequence	5
2	Tighten bolts 1 through 8 in sequence	an additional 90° (¼ turn)

Right Timing Chain Cover Tightening Specifications

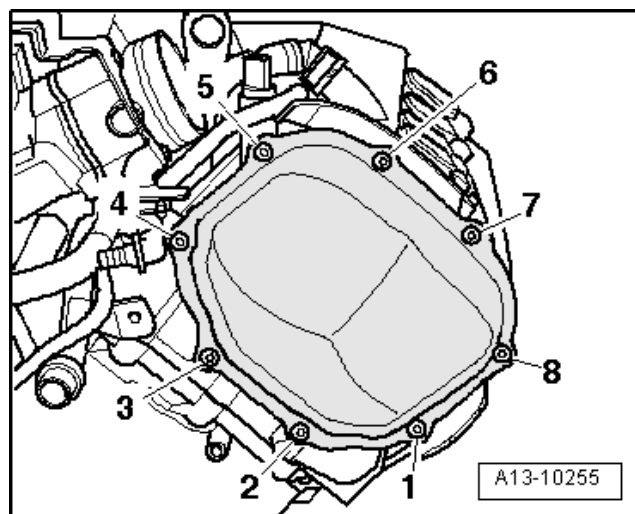

Step	Component	Nm
1	Tighten bolts 1 through 8 in sequence	5
2	Tighten bolts 1 through 8 in sequence	an additional 90° (¼ turn)

Lower Timing Chain Cover Tightening Specifications

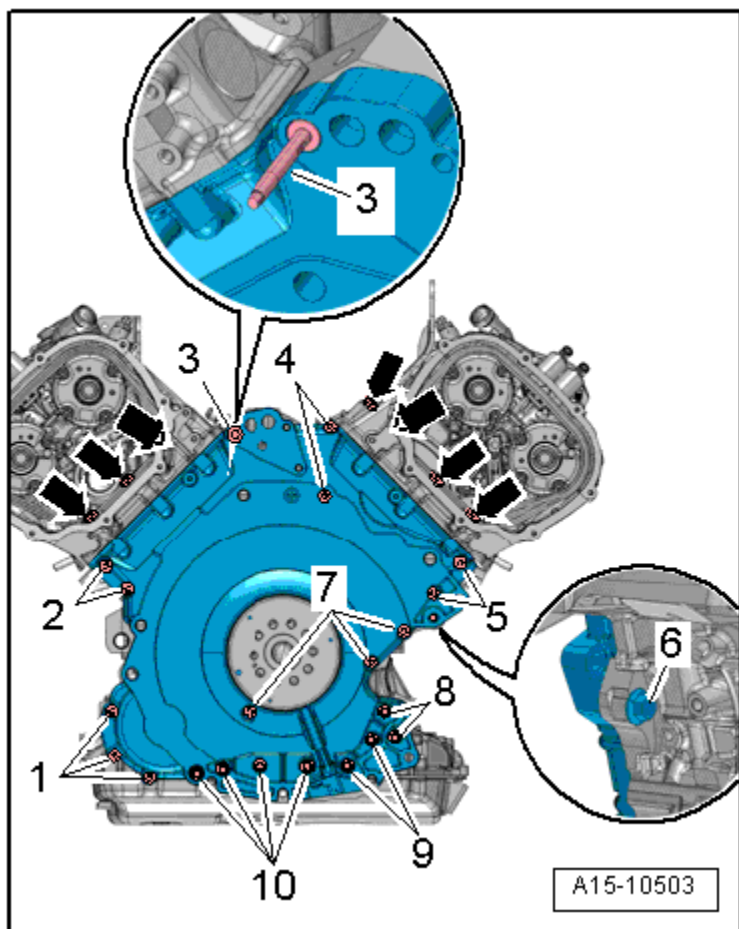

Securing with Aluminum Bolts

Step	Bolts	Tightening Specification/ Additional Angle of Rotation
1	➡	3 Nm
2	1 through 10	3 Nm in a diagonal sequence
3	1, 2, 4, 5, 7	Tighten an additional 90° (¼ turn)
4	➡	9 Nm
5	8, 9, 10	8 Nm
6	8, 9, 10	Tighten an additional 90° (¼ turn)

Step	Bolts	Tightening Specification/ Additional Angle of Rotation
7	3	16 Nm
8	6	20 Nm
9	6	Tighten an additional 180° (½ turn)

Securing with Steel Bolts

Tighten steel bolts in stages as follows:

Step	Bolts	Tightening Specification/ Additional Angle of Rotation
1	➡	3 Nm
2	1 through 10	3 Nm in a diagonal sequence
3	1, 2, 4, 5, 7 and ➡	9 Nm
4	8, 9, 10	20 Nm
5	3	16 Nm
6	3	70 Nm

Camshaft Guide Frame Tightening Specifications

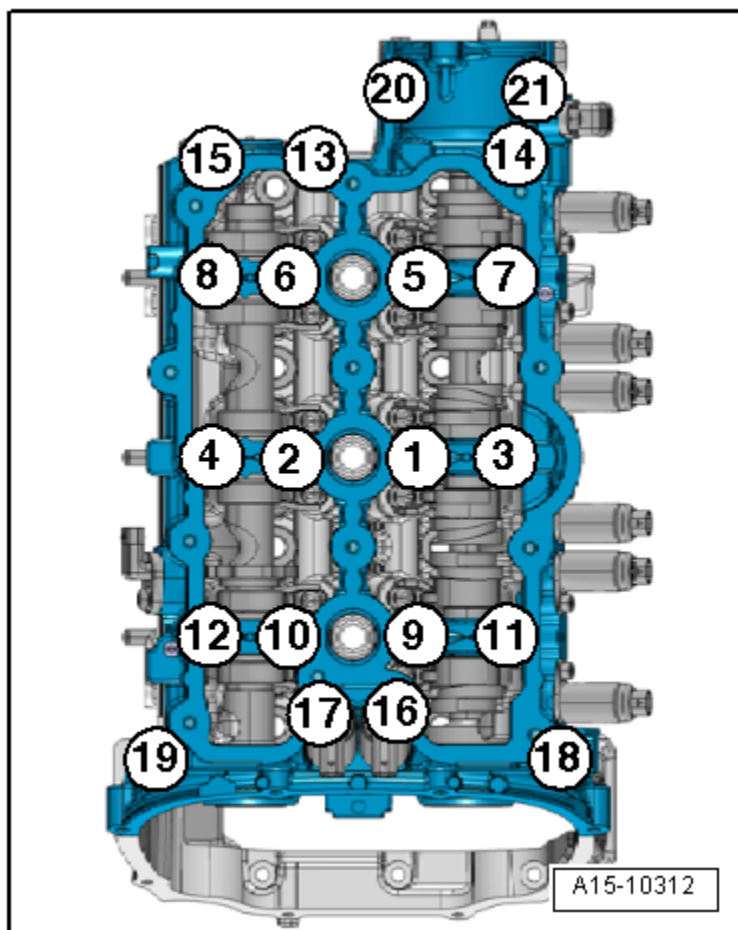

Step	Component	Nm
1	Tighten bolts 1 through 21 in sequence (The guide frame must be in contact with the entire contact surface of the cylinder head)	Hand-tighten
2	Tighten bolts 1 through 21 in sequence	8
3	Tighten bolts 1 through 21 in sequence	an additional 90° (¼ turn)

Engine Lubrication – 3.0L CGXC, CTUB

Fastener Tightening Specifications

Component	Nm
Bracket for driveshaft for oil pump	9
Chain sprocket for oil pump ¹⁾	30 plus an additional 90° (¼ turn)
Cover with oil separator	2.5
Crankcase ventilation hose	2.5
Engine oil cooler	9
Lower oil baffle	
- Aluminum bolts ¹⁾	3 plus an additional 90° (¼ turn)
- Steel bolts	9
Oil drain plug	30
Oil filter housing ²⁾	
	13
Union nut	13
	9
Oil check valve	20
Oil filter housing cap	25
Oil level thermal sensor, nut	9
Oil pressure switch	20
Oil pump	20
Reduced oil pressure switch	20
Threaded Pin	16
Upper oil baffle	
- Aluminum bolts ¹⁾	3 plus an additional 90° (¼ turn)
- Steel bolts	9

¹⁾ Always replace

²⁾ For bolt tightening clarification, refer to ElsaWeb under *Oil Filter Housing and Oil Pressure Switch Overview, items 1, 4, 5, and 13.*

Upper Oil Pan Tightening Specifications

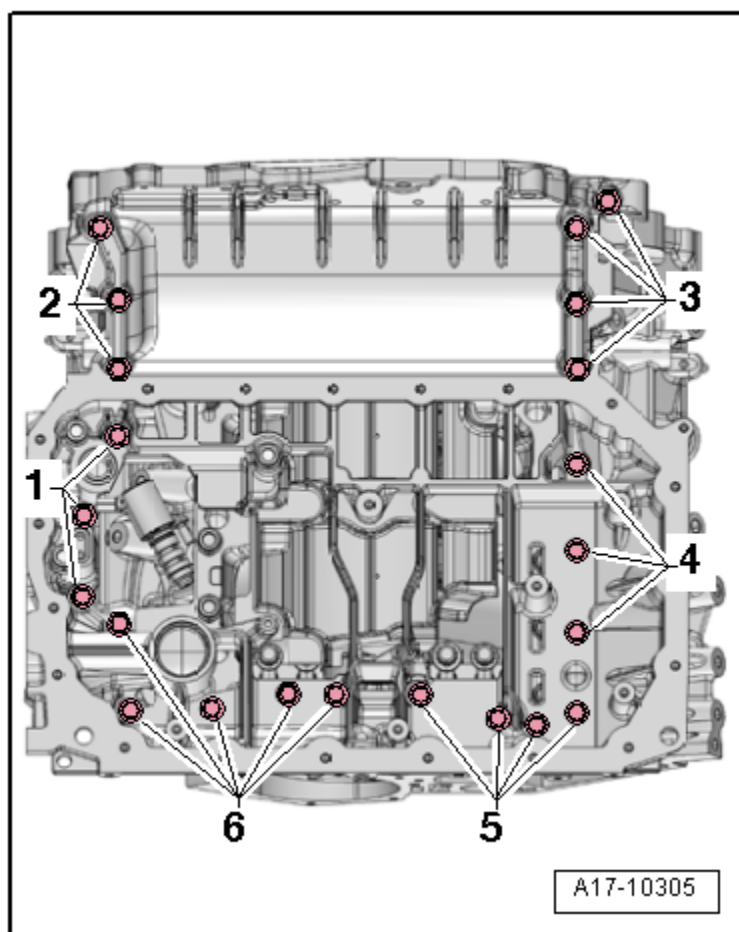

Bolt Threads	Tightening Specification/
M7	Diagonally in steps at least to 16 Nm
M8	Diagonally in steps at least to 20 Nm

Lower Oil Pan Tightening Specifications

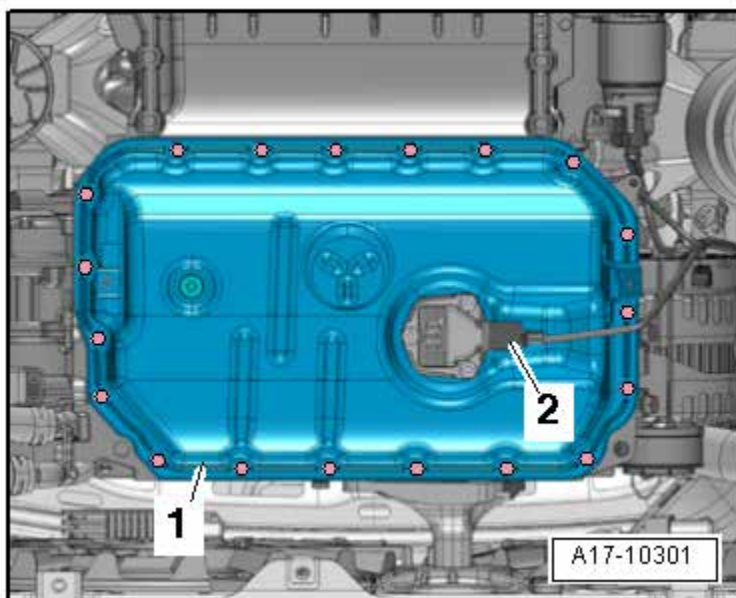

Replace any bolts that were tightened with an additional turn.
Tighten bolts in 2 stages as follows:

Step	Tightening Specification/Additional Turn
1	8 Nm in a diagonal sequence
2	an additional 90° (¼ turn) in diagonal sequence

Fuel Injection – 3.0L CGXC

Fuel Injection System Test Data

3.0L TFSI engine	
Engine idle speed	Cannot be adjusted, it is regulated by idle stabilization
Fuel pressure before high pressure pump	3.0 to 6.0 bar pressure
Fuel pressure after high pressure pump	30 to 125 bar pressure

Fastener Tightening Specifications

Component	Nm
Bracket for high-pressure lines	9
Camshaft Position (CMP) sensor	9
E-box cover	3.5
Engine Speed (RPM) sensor	9
Fuel pressure sensor ¹⁾	22
Fuel rail retaining bracket	
- Bolt	9
- Nut	9
- Bolt	2.5
High pressure fuel line	27
High pressure lines	27
High- pressure lines to bracket bolt	9
High pressure line shield nut	9
High Pressure Pump	
- Tighten by hand in a diagonal sequence	5
- Final tightening specification	20
Housing double bolt	9
Intake manifold runner position sensor to intake manifold runner control vacuum actuator bolt	2.5
Low fuel pressure sensor	15
Oxygen sensor ³⁾	55
Threaded connection to fuel rail	40
Threaded connection to high pressure pump	27

¹⁾ Coat the thread with oil.

²⁾ For bolt tightening clarification, refer to ElsaWeb under *Lower Intake Manifold Section Overview and see items -10, 11 and 12-*

³⁾ Coat new oxygen sensors with an assembly paste

Lower Intake Manifold Tightening Specification

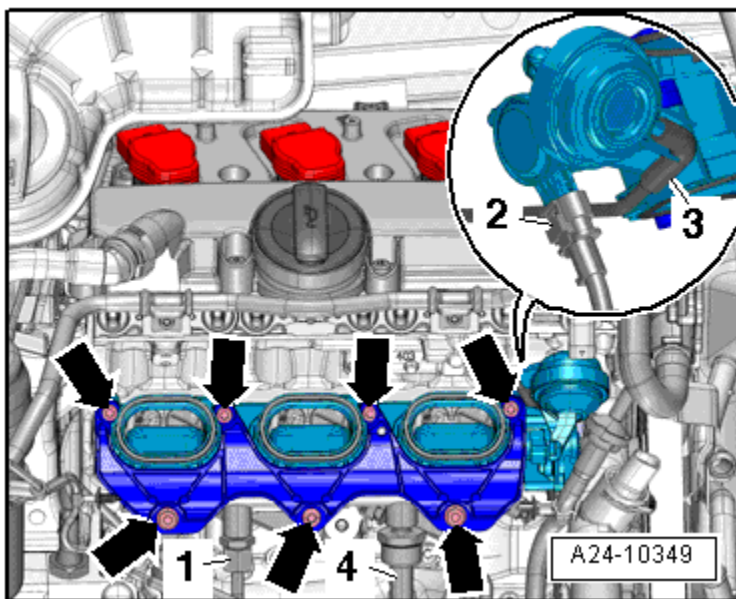

Engine –
3.0L CGXC, CTUB

Component	Nm
Tighten the lower intake manifold bolts and nuts → diagonally in steps	10

Ignition – 3.0L CGXC

Ignition System Test Data

Engine code		3.0L TFSI engine
Engine idle speed		Cannot be adjusted, it is regulated by idle stabilization
Ignition timing		Not adjustable, regulated by the control module
Ignition/Glow Plug System		Single coil ignition system with 6 ignition coils (output stages integrated) that are connected directly to spark plugs via the ignition cables.
Spark plugs	Names	Refer to Data sheets for exhaust emission test.
	Tightening Specifications	Refer to Maintenance Procedures Rep. Gr. 03.
Ignition sequence		1-4-3-6-2-5

Fastener Tightening Specifications

Component	Nm
Camshaft adjustment valve	5
Camshaft Position (CMP) sensor	9
Engine Speed (RPM) sensor	9
Knock Sensor (KS)	20
Wiring harness	5

Fuel Supply System – 3.0L CGXC

Fastener Tightening Specifications

Component	Nm
Accelerator pedal module mounting bolt	8
Carrier plate	20
EVAP canister mounting bolt	16
Fuel filler neck to body bolt	20
Fuel pump control module bolt	2.5
Fu Locking flange cover bolt el tank heat shield nut	2
Leak detection pump nut	5
Leak detection pump to EVAP canister bolt	4
Locking flange cover bolt	1.5
Shield to fuel filler tube bolt	8
Union nut	120

Engine Cooling – 3.0L CGXC

Fastener Tightening Specifications

Component	Nm
After-run coolant pump	4
After-run coolant pump bracket	9
Bracket for front left coolant pipes	22
Bracket for left charge air cooling circuit radiator, nut	9
Charge Air Coolant (CAC) pump bracket, nut	9
Coolant hose connecting piece	9
Coolant thermostat	9
Coolant pump	9
Engine temperature control sensor	3
Fan shroud, version 1	4.5
Fan shroud, version 2	3.5
Front charge air cooling circuit radiator	4.5
Front coolant pipe ³⁾	9
Idler roller for ribbed belt	42
Left front coolant pipes ²⁾	3 plus an additional 90° (¼ turn)
Lower coolant pipe on the supercharger	5
Radiator bracket ¹⁾	4.5
	5
Ribbed belt pulley for coolant pump	20
Upper coolant pipe	9
Upper coolant pipe on the compressor	5

¹⁾ For bolt tightening clarification, refer to ElsaWeb under *Radiator and Coolant Fan Overview and see items -22 and 23-*.

²⁾ Replace

³⁾ For bolt tightening clarification, refer to ElsaWeb under *Coolant Pipes Overview and see items 6 and 7.*

Supercharger – 3.0L CGXC

Fastener Tightening Specifications

Component	Nm
Bleeder screw	1.5 to 3.0
Changeover valve bracket	9
Charge air pressure sensor ¹⁾	10
Drive head ¹⁾	25
Engine lifting eye	27
Insulation plate	5
Left charge air cooler ¹⁾	10
Right charge air cooler ¹⁾	10
Structure Borne Sound Control Module -J869-, nuts	5
Structure-Borne Sound Actuator -R214-, nut	5

¹⁾ Always replace

Supercharger Tightening Specifications

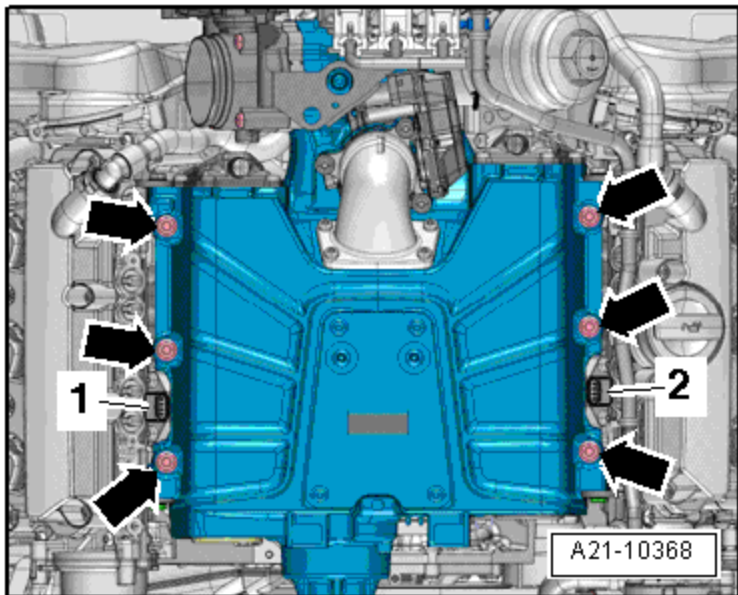

Component	Nm
Threaded pin	17
Nuts (tighten diagonally in stages)	20

Exhaust System – 3.0L CGXC

Fastener Tightening Specifications

Component	Nm
Bracket for Secondary Air Injection (AIR) pump motor, nut and bolt	9
Bracket for the secondary air injection hose	9
Catalytic converter, nut ^{1) 4)}	23
Center muffler, nut ¹⁾	23
Front clamping sleeve, nut	23
Heat shield	9
Left Secondary Air Injection (AIR) combination valve	9
Rear clamping sleeve, nut	23
Right Secondary Air Injection (AIR) combination valve	9
Secondary air hose	9
Suspended mount ²⁾	23
Suspended mount ^{1) 3)}	20

¹⁾ Always replace.

²⁾ For bolt tightening clarification, refer to ElsaWeb under *Muffler Overview*“ and see *items -2 and 22-*

³⁾ For bolt tightening clarification, refer to ElsaWeb under *Muffler Overview*“ and see *items -16-*

⁴⁾ Coat the thread with hot bolt paste

Left Exhaust Manifold Tightening Specifications

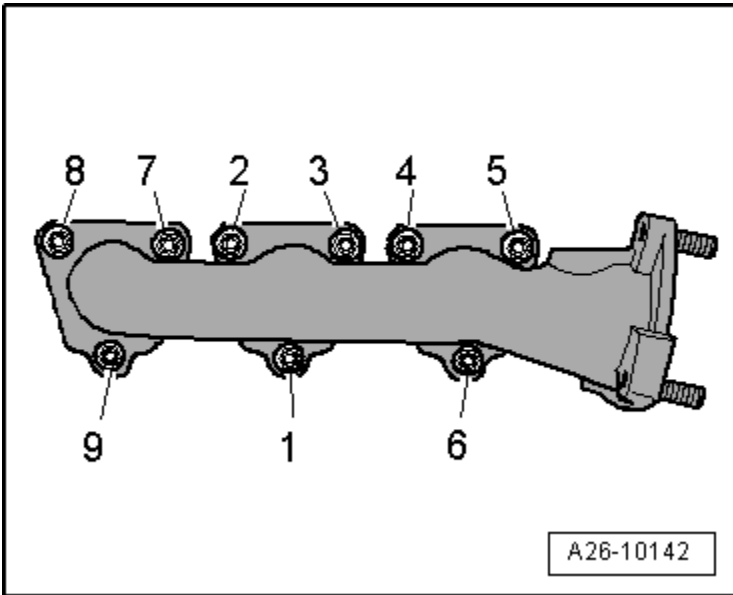

Stage	Nuts	Tightening Specifications
1	-1 through 9-	Install all the way in by hand.
2	-1 through 9-	15 Nm
3	-1 through 9-	25 Nm

Right Exhaust Manifold Tightening Specifications

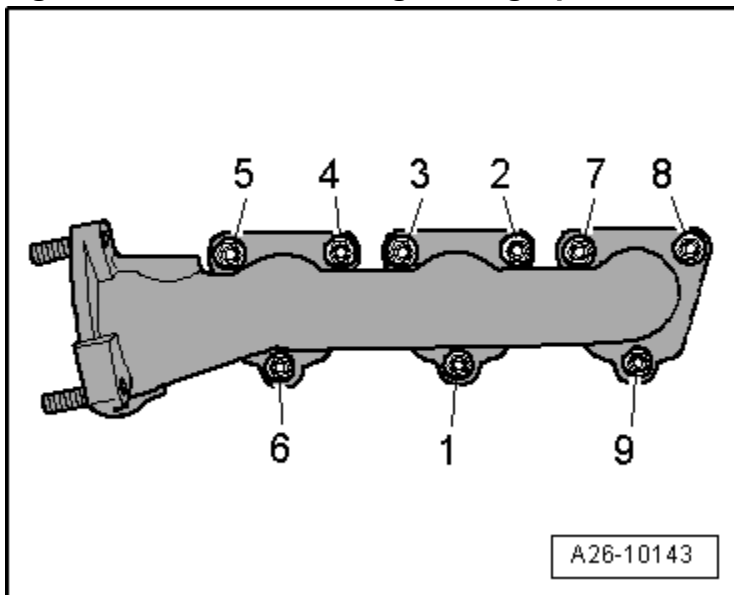

Engine –
3.0L CGXC, CTUB

Stage	Nuts	Tightening Specifications
1	-1 through 9-	Install all the way in by hand.
2	-1 through 9-	15 Nm
3	-1 through 9-	25 Nm

MANUAL TRANSMISSION – 0B2

General, Technical Data – 0B2

Transmission Identification

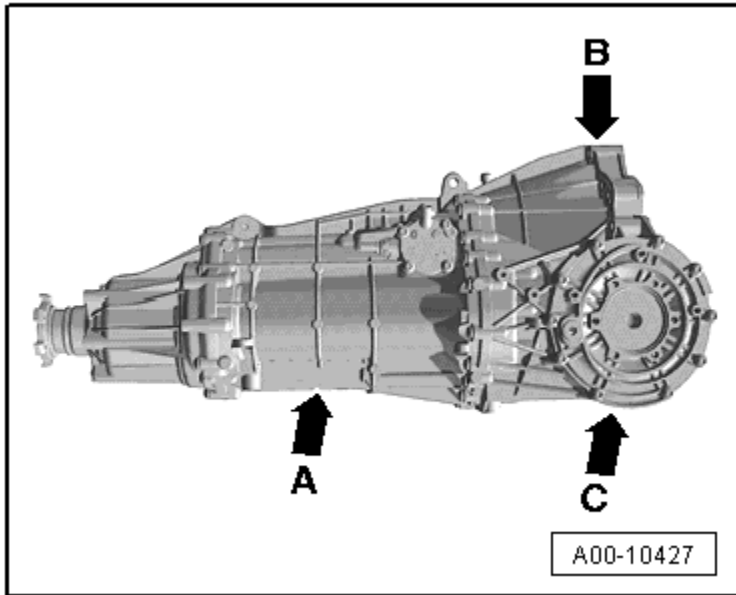

- A** ➡ - Manual transmission 0B1/2.
- B** ➡ - Engine code and production date.
- C** ➡ - Code letters and production date.

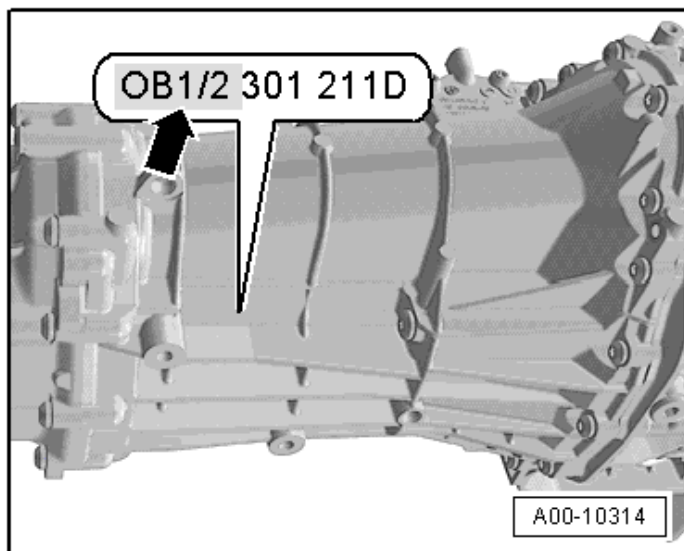

0B1 = Front wheel drive transmission.
0B2 = All wheel drive transmission.

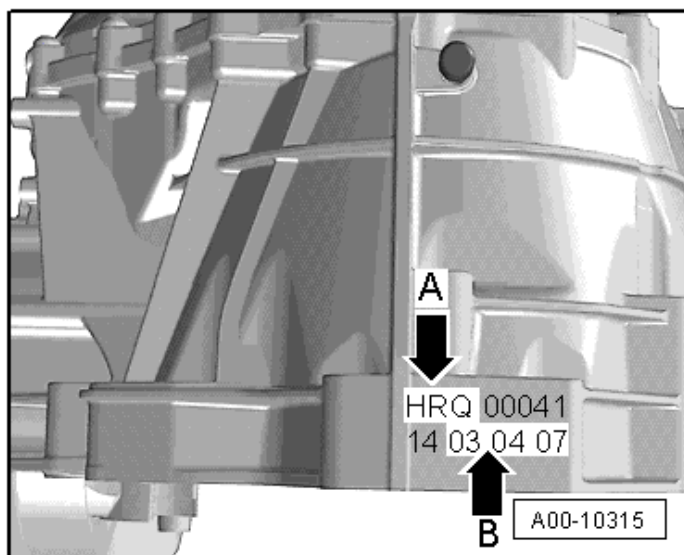

Transmission Code - A ➡ and Production Date - B ➡.

Example:	HRQ	03 04 07
	Identification code	Production date: 04.03.2007

The transmission code letters are also listed on the vehicle data stickers.

Code Letters, Assembly Allocation, Ratios, Capacities

The following information can be found in the Electronic Parts Catalog ETKA:

- Production date
- Transmission fluid specification
- The individual gear ratios
- Flange shaft allocation
- The dual mass flywheel allocation
- Clutch disc and pressure plate allocation
- Rear final drive allocation using code and PR number

Manual Transmission		6-Speed 0B2 AWD		
Identification codes		KCA	LLT	LRY
Allocation	Type	Audi A4 from MY 2008	Audi A4 from MY 2008	Audi A4 from MY 2008
	Engine	2.0L - 155 kW	2.0L - 155 kW	2.0L - 155 kW
Ratio	Final drive	38:11 = 3.455	38:11 = 3.455	38:11 = 3.455
	Intermediate drive	31:29 = 1.069	31:29 = 1.069	31:29 = 1.069
Capacity		4.5 liters		

Manual Transmission		6-Speed 0B2 AWD		
Identification codes		MRR	NSN	NSP
Allocation	Type	Audi A4 from MY 2008	Audi A4 from MY 2008	Audi A4 allroad from MY 2008
	Engine	2.0L - 155 kW	2.0L - 155 kW	2.0L - 155 kW
Ratio	Final drive	38:11 = 3.455	38:11 = 3.455	29:8 = 3.625
	Intermediate drive	31:29 = 1.069	31:29 = 1.069	31:29 = 1.069
Capacity		4.5 liters		

Manual Transmission		6-Speed 0B2 AWD		
Identification codes		KVS	LLY	LSC
Allocation	Type	Audi A4 from MY 2008	Audi A4 from MY 2008	Audi A4 allroad from MY 2008
	Engine	2.0L - 155 kW	2.0L - 155 kW	2.0L - 155 kW
Ratio	Final drive	38:11 = 3.455	38:11 = 3.455	29:8 = 3.625
	Intermediate drive	31:29 = 1.069	31:29 = 1.069	31:29 = 1.069
Capacity		4.5 liters		

Manual Transmission		6-Speed 0B2 AWD		
Identification codes		MRS	MVV	PJB
Allocation	Type	Audi A4 allroad from MY 2008	Audi A4 allroad from MY 2008	Audi A4 allroad from MY 2008
	Engine	2.0L - 155 kW	2.0L - 155 kW	2.0L - 165 kW
Ratio	Final drive	29:8 = 3.625	29:8 = 3.625	29:8 = 3.625
	Intermediate drive	31:29 = 1.069	31:29 = 1.069	31:29 = 1.069
Capacity		4.8 liters		

Transmission Specifications

Manual transmission		6 speed 0B2 AWD	
Identification code		KCA	
Manufactured	from	06.08	
	to		
Allocation	Model	Audi A4 from MY 2008	
	Engine	2.0L - 155 kW	
Gear ratios	Final drive	38:11 = 3.455	
	Intermediate drive	31:29 = 1.069	
$Z_2 : Z_1 = i$	1 st gear	34:9 = 3.778	
	2 nd gear	41:20 = 2.050	
	3 rd gear	37:28 = 1.321	
	4 th gear	32:33 = 0.970	
	5 th gear	30:37 = 0.811	
	6 th gear	27:39 = 0.692	
	Reverse gear	30:9 = 3.333	
Total in top gear		2.557	
Capacities		4.8 liters	
Specification		Transmission oil G 052 911 A SAE 75 W 90 (synthetic oil)	
Hydraulic		Hydraulic	

Obtain the following information from the Electronic Parts Catalog ETKA:

- Flange shaft allocation
- The dual mass flywheel allocation
- Clutch disc and pressure plate allocation
- Rear final drive allocation using code and PR number

Securing Transmission to Engine

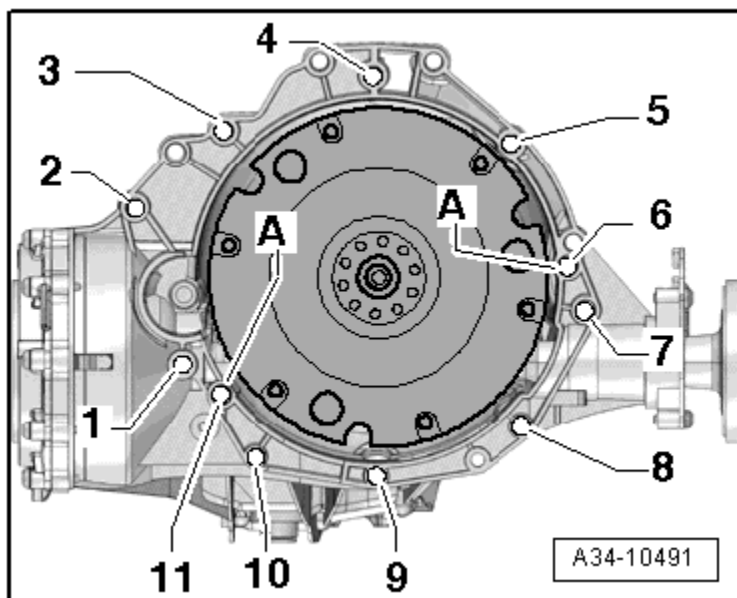

Item	Bolt	Nm
1 ³⁾	M10 x 50 ¹⁾	65
2 ³⁾ , 7	M12 x 100 ²⁾	30 plus an additional 90° (¼ turn)
3 ⁴⁾ , 6	M12 x 75 ²⁾	30 plus an additional 90° (¼ turn)
4 and 5 ⁴⁾	M12 x 120 ²⁾	30 plus an additional 90° (¼ turn)
8 through 10	M10 x 75 ²⁾	15 plus an additional 90° (¼ turn)
11	M12 x 50 ²⁾	30 plus an additional 90° (¼ turn)
A	Alignment sleeves for centering	

- 1) Steel bolt - do not replace.
- 2) Replace.
- 3) Also secures the starter.
- 4) Also secures the wiring bracket.

Aluminum bolts 2 through 10 can only be used twice. After using the bolts once, use a chisel and mark the bolts with two notches (X). To prevent damaging the bolts when marking them, do not clamp them in a vise. Use a ½" drive 14 mm socket and extension clamped into a vise. Do not use bolts that have been marked with an X.

Clutch – 0B2

Fastener Tightening Specifications

Component	Nm
Bleeder screw	5.5
Bracket for the pipe line mounted on the transmission	20
Clutch module to drive plate bolt ¹⁾	60
Clutch slave cylinder-to-transmission	20

¹⁾ Replace

Fastener Tightening Specifications – Internal Components

Component	Nm
Ball studs	25
Guide sleeve securing plate	8
Pressure plate (always replace)	22 plus an additional 90° (¼ turn)

¹⁾ Replace

Controls, Housing – 0B2

Fastener Tightening Specifications

Component	Bolt Size	Nm
Bolts and nuts	M6	9
	M7	15
	M8	20
	M10	40
	M12	65
Clamping plate	-	23
Connecting rod	-	20
Gearshift lever nut (always replace)	-	20
Joint piece between the selector rod and shift lever		
- Bolt	-	23
- Nut	-	10
Lower stop for the transmission mount (always replace)	-	20 plus an additional 90° (¼ turn)
Mount for the shift lever support	-	8
Push rod	-	20
Sealing boot	-	4

Fastener Tightening Specifications

Component	Bolt Size	Nm
Selector shaft cover (always replace)	-	10 plus an additional 45° ($\frac{1}{8}$ turn)
Shift lever support	-	23
Transmission fluid filler plug	-	45
Transmission neutral position sensor (always replace)	-	10 plus an additional 45° ($\frac{1}{8}$ turn)
Transmission range gear recognition switch	-	20
Transmission shift lever (always replace)	-	20
Tunnel crossmember		
- Bolt	-	70
- Nut	-	20
Tunnel support		
- Bolt	-	40
- Nut	-	20

Fastener Tightening Specifications – Internal Components

Component	Bolt Size	Nm
Ball studs		25
Bearing bracket to the transmission cover	M8 x 30	20 plus an additional 30° ($\frac{1}{12}$)
Center differential housing (always replace) ²⁾		
Bolt	-	10 plus an additional 90° ($\frac{1}{4}$ turn)
Double bolt	-	15 plus an additional 90° ($\frac{1}{4}$ turn)
Bolt	-	15 plus an additional 90° ($\frac{1}{4}$ turn)
Cover for final drive	M8 x 38	20 plus an additional 90° ($\frac{1}{4}$ turn)
Flange shaft, left	M8 x 25	15 plus an additional 45° ($\frac{1}{8}$ turn)
Oil drain plug	-	45
Oil fill plug	-	45
Output shaft	-	200

Component	Bolt Size	Nm
Sealing cap 1	M8 x 22	10 plus an additional 45° ($\frac{1}{8}$ turn)
Securing plate		8
Selector shaft with selector cover (always replace)	M8 x 22	10 plus an additional 45° ($\frac{1}{8}$ turn)
Side shaft (always replace)	-	150 plus an additional 90° ($\frac{1}{4}$ turn)
Transmission cover	M8 x 50	15 plus an additional 90° ($\frac{1}{4}$ turn)
	M8 x 33 (always replace)	10 plus an additional 90° ($\frac{1}{4}$ turn)
Transmission neutral position sensor (always replace)	M8 x 22	10 plus an additional 45° ($\frac{1}{8}$ turn)
Transmission range gear recognition switch	-	20
Vibration damper	-	15 plus an additional 90° ($\frac{1}{4}$ turn)

¹⁾ For bolt tightening clarification, refer to ElsaWeb under Center Differential Housing and Center Differential Assembly Overview, items 2, 3, and 4.

Gears, Shafts – 0B2

Fastener Tightening Specifications

Component	Nm
Input shaft	200
Output shaft	200
Shift fork group-to-bearing bracket	20 plus an additional 45° ($\frac{1}{8}$ turn)

Rear Final Drive, Differential – 0B2

Fastener Tightening Specifications

Component	Bolt Size	Nm
Balance weight bolt ¹⁾	-	
Center differential housing ²⁾		
- Aluminum bolts ¹⁾	M8 x 35	10 plus an additional 90° (¼ turn)
- Aluminum bolts ¹⁾	-	10 plus an additional 90° (¼ turn)
- Steel bolts	M8 x 38	15 plus an additional 90° (¼ turn)
- Steel bolts	M8 x 55	15 plus an additional 90° (¼ turn)
Center differential housing ³⁾		
- Aluminum bolts	-	8 plus an additional 120°
- Steel bolts	-	15 plus an additional 90° (¼ turn)
Drive axle heat shield to transmission	-	23

¹⁾ Always replace

²⁾ For bolt tightening clarification, refer to ElsaWeb under *Center Differential Housing with Bolted Driveshaft Overview* and see items -2, 3 and 4-.

³⁾ For bolt tightening clarification, refer to ElsaWeb under *Center Differential Housing with Connected Driveshaft Overview* and see items -2 and 11-.

Fastener Tightening Specifications – Internal Components

Component	Bolt Size	Nm
Final drive cover	M8 x 38	20 plus an additional 90° (¼ turn)
Flange shaft, left	M8 x 25	15 plus an additional 45° (⅛ turn)

MANUAL TRANSMISSION – 0B4

General, Technical Data – 0B4

Transmission Identification

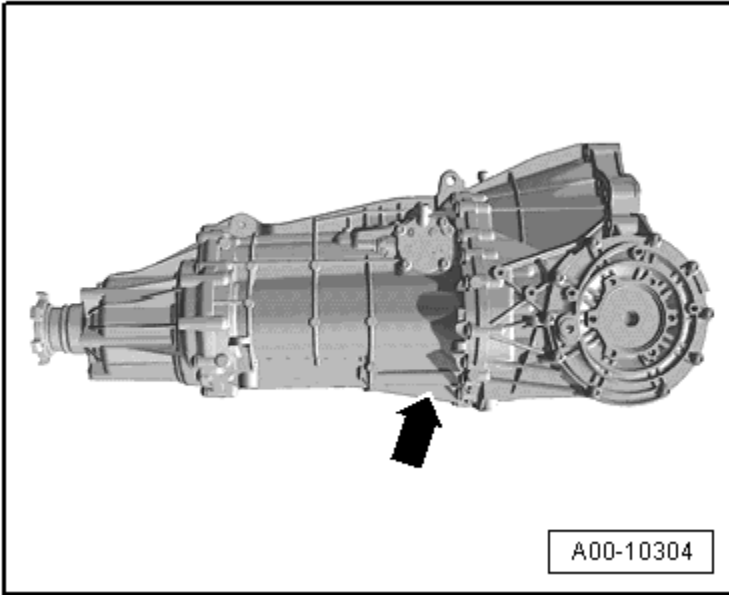

Transmission code, serial number and transmission part number ➡.

Manual Trans. –
0B4

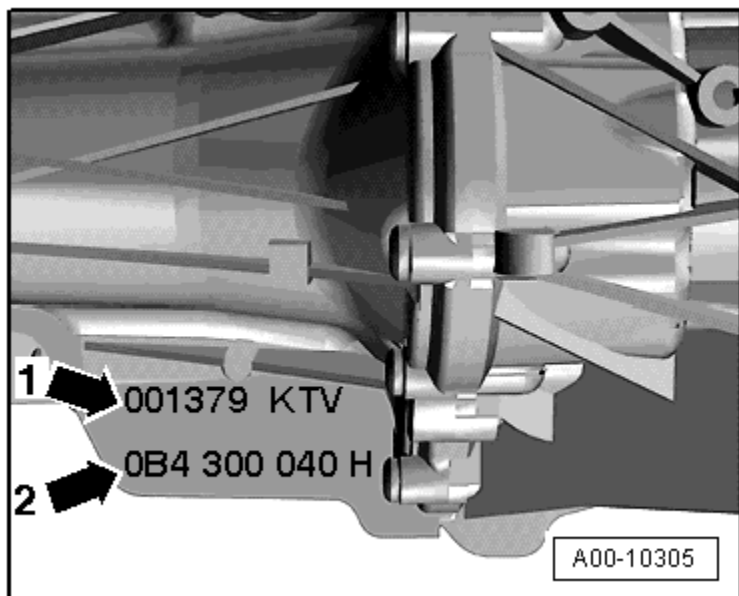

Transmission code letters and serial number (1 ➔).

Example:	001379	KTV
	Serial number	Identification codes

Manual transmission 0b4 with transmission part number.
For example: 0B4 300 040 H (2 ➔).

Engine Codes, Transmission Allocation, Ratios and Capacities

The following information can be found in the Electronic Parts Catalog ETKA.

- Transmission fluid specification
- Flange shaft allocation
- The dual mass flywheel allocation
- Clutch disc and pressure plate allocation
- Rear final drive allocation using code and PR number

Manual Transmission		6-speed 0B4 AWD	
Identification codes		KMR	LPE
Manufactured	from	01.09	03.10
	through	03.10	
Allocation	Type	Audi A4 2008 ►	Audi A4 2008 ►
	Engine	3.0L TFSI - 245 kW S4	3.0L TFSI - 245 kW
Ratio	Final drive	31:9 = 3.444	31:9 = 3.444
	Intermediate drive	31:29 = 1.069	31:29 = 1.069
Z ₂ :Z ₁ =i	1 st Gear	33:9 = 3.667	33:9 = 3.667
	2 nd Gear	41:19 = 2.158	41:19 = 2.158
	3 rd Gear	38:25 = 1.520	38:25 = 1.520
	4 th Gear	34:30 = 1.133	34:30 = 1.133
	5 th Gear	34:37 = 0.919	34:37 = 0.919
	6 th Gear	35:45 = 0.778	35:45 = 0.778
	Reverse gear	29:9 = 3.222	29:9 = 3.222
Gears in the highest gear		2.864	2.864
Capacity		3.8 liters	

Manual Trans. –
0B4

Securing Transmission to Engine

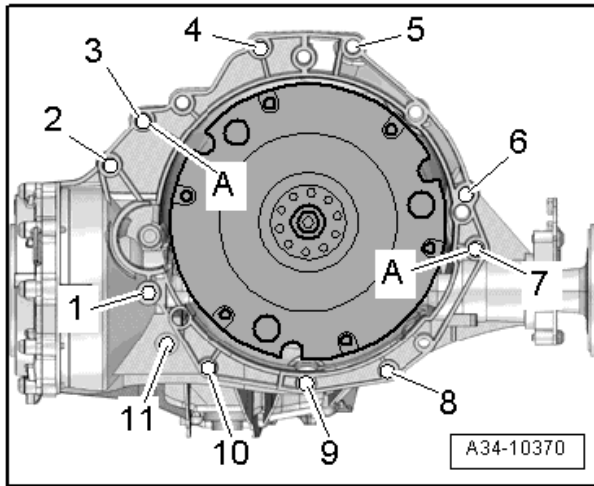

Item	Bolt	Nm
1 ¹⁾	M10 x 50 ²⁾	65
2 ¹⁾	M12 x 100 ³⁾⁴⁾	30 plus an additional 90° (¼ turn)
3 to 6	M12 x 100 ³⁾⁴⁾	30 plus an additional 90° (¼ turn)
7	M12 x 125 ³⁾⁴⁾	30 plus an additional 90° (¼ turn)
8, 11	M10 x 60 ³⁾⁴⁾	15 plus an additional 90° (¼ turn)
9, 10	M10 x 95 ³⁾⁴⁾	15 plus an additional 90° (¼ turn)
A	Alignment sleeves for centering	

¹⁾ Also secures the starter.

²⁾ Bolt strength rating 10.9. There is no limit to the number of times steel bolts may be used.

³⁾ Audi A4 through VIN 8K-9-066499, Audi A5 through VIN 8T-9-007999: Replace the aluminum bolts.

⁴⁾ Audi A4 from VIN 8K-9-066500, Audi A5 from VIN 8T-9-008000: The aluminum bolts may be used twice. Check the aluminum bolts (2 through 11) to see whether they can be reused (below).

Audi A4 from VIN 8K-9-066500, Audi A5 from VIN 8T-9-008000: The aluminum bolts (refer to figure) may be used twice. After using the bolts once, use a chisel and mark the bolts with two notches (X). To prevent damaging the bolts when marking them, do not clamp them in a vise. Use a ½" drive 14 mm socket and extension clamped into a vice. Do not use bolts that have been marked with an X. Audi A4 through VIN 8K-9-066499: Always replace the aluminum bolts. Audi A5 through VIN 8T-9-007999: Always replace the aluminum bolts. There is no limit to the number of times the steel bolt can be used.

Clutch – 0B4

Fastener Tightening Specifications

Component	Bolt Size	Nm
Base block for the shift lever support nut	-	8
Bolts and Nuts	M6	9
	M7	15
	M8	20
	M10	40
	M12	65
Center differential housing ¹⁾		
- Aluminum bolts ²⁾	-	10 plus an additional 90° (¼ turn)
- Steel bolts	-	24
Clamping plate	-	23
Connecting rod	-	20
Driveshaft heat shield to center differential housing	-	25
Gearshift lever ²⁾	-	20
Joint piece between the selector rod and shift lever		
- Nut	-	10
- Bolt	-	23
Lower stop for the transmission mount ²⁾	-	20 plus an additional 90° (¼ turn)
Mount for the shift lever support, nut	-	8
Transmission support		
- Nut	-	20
- Bolt	-	40
Oil filler plug	-	40
Push rod	-	20
Sealing boot	-	4
Shift lever support	-	23
Transmission fluid filler plug	-	40
Transmission range gear recognition switch bolt	-	20
Transmission shift lever nut	-	20
Selector shaft cover	-	24
Tunnel crossmember		
- Nut	-	20
- Bolt	-	70

¹⁾ For bolt tightening clarification, refer to *Center Differential and Center Differential Housing Overview* items 1 and 3

²⁾ Always replace

Fastener Tightening Specifications – Internal Components

Component	Nm
Ball studs	25
Guide sleeve securing plate ¹⁾	8
Sac pressure plate (always replace)	22 plus an additional 90° (¼ turn)

1) Different bolt lengths

Controls, Housing – 0B4

Fastener Tightening Specifications

Component	Bolt Size	Nm
Base block for the shift lever support nut	-	8
Center differential housing ¹⁾		
Aluminum bolts ²⁾	-	10 plus an additional 90° (¼ turn)
Steel bolts	-	24
Clamping plate	-	23
Connecting rod	-	20
Driveshaft heat shield-to-center differential housing	-	25
Gearshift lever ²⁾	-	20
Joint piece between the selector rod and shift lever		
- Nut	-	10
- Bolt	-	23
Transmission mount lower stop ²⁾	-	20 plus an additional 90° (¼ turn)
Transmission support		
- Nut	-	20
- Bolt	-	40
Oil filler plug	-	40
Push rod	-	20
Sealing boot	-	4
Shift lever support	-	23
Transmission fluid filler plug	-	40
Transmission range gear recognition switch F208 to the transmission	-	20
Transmission shift lever nut	-	20
Selector shaft cover	-	24
Shift lever support	-	23

Component	Bolt Size	Nm
Tunnel crossmember		
Nut	-	20
Bolt	-	70
Bolts and nuts	M6	9
	M7	15
	M8	20
	M10	40
	M12	65

¹⁾ For bolt tightening clarification, refer to ElsaWeb under *Center Differential and Center Differential Housing Overview, items 1 and 3.*

²⁾ Always replace

Fastener Tightening Specifications – Internal Components

Component	Bolt Size	Nm
Ball studs transmission housing	-	25
Bearing bracket to the transmission cover steel bolts (30 mm long) ²⁾	M8	27
Cap steel bolts (25 mm long) ²⁾	M8	24
Center differential housing		
Steel bolts (63 mm long)	M8	24
Aluminum bolts (42 mm long) ¹⁾	M8	10 plus an additional 90° (¼ turn)
Clutch release lever with release bearing and spring ²⁾	-	8
Final drive cover steel bolts (42 mm long)	M8	24
Left flange shaft steel bolts (25 mm long)	M8	24
Oil drain plug	-	40
Oil fill plug	-	40
Output shaft ¹⁾	-	110
Plate ²⁾	-	24
Reverse shaft-to-transmission cover	-	24
Securing plate	-	8
Selector shaft with selector cover, steel bolts (25 mm long) ²⁾	M8	24
Transmission cover, steel bolts (42 mm long)	M8	24
Transmission neutral position sensor, steel bolt (25 mm long) ²⁾	M8	24
Transmission range gear recognition switch	-	20
Vibration damper ²⁾	-	24

¹⁾ Always replace

²⁾ Insert with locking fluid AMV 185 101 A1

Gears, Shafts – 0B4

Fastener Tightening Specifications

Component	Nm
Bearing bracket steel bolts (M8; 45 mm long) ¹⁾	24

1) Insert with locking fluid AMV 185 101 A1

Rear Final Drive, Differential – 0B4

Fastener Tightening Specifications

Component	Bolt Size	Nm
Final drive cover	M8	24
Drive axle heat shield to transmission	-	23

Fastener Tightening Specifications – Internal Components

Component	Bolt Size	Nm
Final Drive Cover, Steel Bolts (42 mm long)	M8	24
Left Flange Shaft, Steel Bolts (25 mm long) ¹⁾	M8	24

1) Insert with locking fluid

DIRECT SHIFT TRANSMISSION, S TRONIC – 0B5

General, Technical Data – 0B5

Transmission Identification

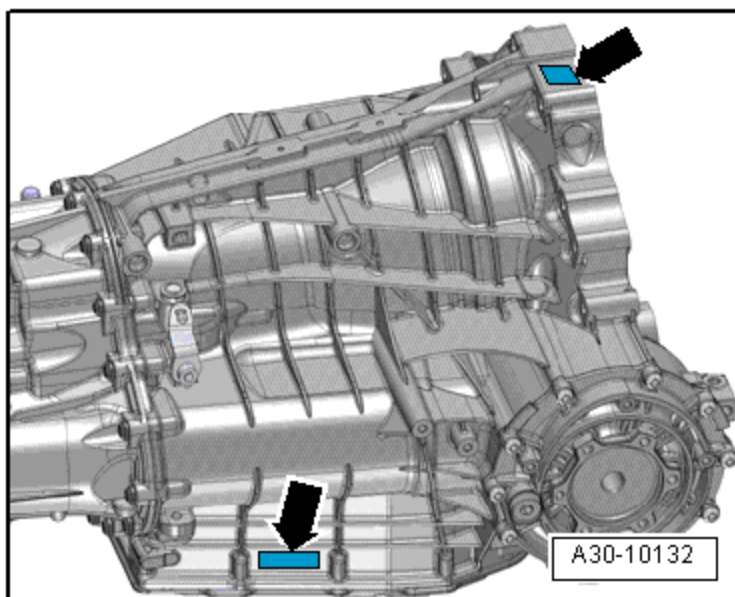

The following details can be found on the transmission housing: ➔.

LHF	Transmission code
D04	Manufacturer key
0026	Serial number
K100808	Factory: K = Kassel Production date: 100808 = 10.08.2008

Direct Shift Trans.,
S tronic – 0B5

Code Letters, Transmission Allocations, Ratios and Equipment

DSG transmission			0B5 AWD	
Transmission	Identification codes		LHK, LJD, MNL, MSE, NGY	NHS, NSC
	Month of production	from to	11.2008	11.2008
Allocation	Model		Audi A4 from MY 2008	Audi A4 from MY 2008
	Engine		3.0L TFSI 245 kW	3.0L TFSI 245 kW
Gear Ratios	1 st gear		48:13 = 3.692	48:13 = 3.692
	2 nd gear		47:21 = 2.238	43:20 = 2.150
	3 rd gear		53:34 = 1.559	45:32 = 1.406
	4 th gear		47:40 = 1.175	41:40 = 1.025
	5 th gear		43:47 = 0.915	37:47 = 0.787
	6 th gear		38:51 = 0.745	30:48 = 0.625
	7 th gear		37:60 = 0.617	27:52 = 0.519
	Reverse gear		53:18 = 2.944	53:18 = 2.944
Gear wheel			31:29 = 1.069	31:29 = 1.069
Bevel gear	Front axle		29:8 = 3.625	29:8 = 3.625
	Rear axle		37:9 = 4.111	37:9 = 4.111
Total ratio "i"	Front axle		3.875	3.875
	Rear axle		2.390	2.011
Spread			6.0	6.0

Securing Transmission to Engine

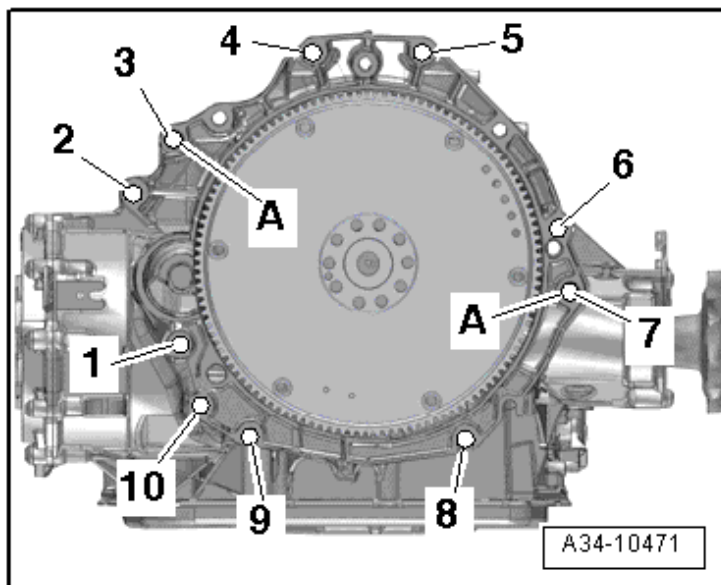

Item	Bolt	Nm
1 ¹⁾	M10 x 50 ²⁾	65
2 ³⁾ , 4 to 6	M12 x 100 ⁴⁾	30 plus an additional 90° (¼ turn)
7	M12 x 125 ⁴⁾	30 plus an additional 90° (¼ turn)
8	M10 x 60 ⁴⁾	15 plus an additional 90° (¼ turn)
9, 10	M10 x 95 ⁴⁾	15 plus an additional 90° (¼ turn)
A	Alignment sleeves for centering	

¹⁾ Also secures the starter.

²⁾ Bolt strength rating 10.9. There is no limit to the number of times steel bolts maybe used.

³⁾ Also secures the starter.

⁴⁾ The bolts may be used twice.

Aluminum bolts 2 through 10 can only be used twice. After using the bolts once, use a chisel and mark the bolts with two notches (X). To prevent damaging the bolts when marking them, do not clamp them in a vise. Use a ½" drive 14 mm socket and extension clamped into a vice. Do not use bolts that have been marked with an X.

Clutch – 0B5

Fastener Tightening Specification

Component	Nm
Dual mass flywheel	60

Tightening Specification and Sequence for the Dual Clutch and Clutch Cover

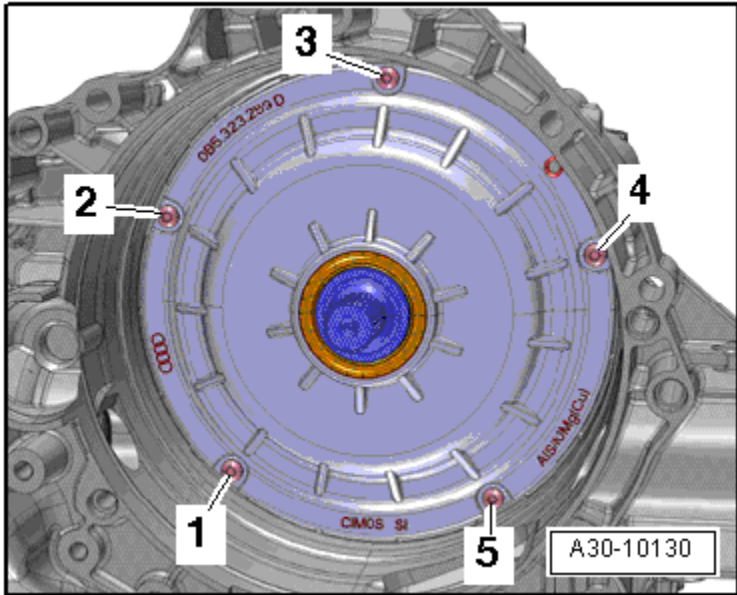

Step	Component	Nm
1	Tighten bolts 1 through 5 in sequence by hand evenly until the bolt head contacts the clutch cover	Hand-tighten
2	Tighten one after the other in 90° steps until the clutch cover contacts the transmission housing	an additional 90° (¼ turn)
3	Tighten bolts 1 through 5 in sequence	8

Controls, Housing – 0B5

Fastener Tightening Specifications

Component	Bolt Size	Nm
Air guide to transmission	-	3
ATF pipe filter to transmission		
- Bolt	-	20
- Union nut	-	29
ATF pipe - hose line - supply to ATF cooler		
- Bolts	-	5
- Bolts	-	9
- Union nut	-	29
ATF return pipe 1		
- Bolt	-	9
- Bolt	-	20
ATF supply pipe		
- Bolt	-	9
- Union nut	-	29
ATF supply pipe/hose/line assembly to ATF cooler	-	5
Bolts and nuts	M6	9
	M7	15
	M8	20
	M10	40
	M12	65
Cable mounting bracket to transmission	-	8
Drive axle Heat Shield to front final drive	-	23
Filter Housing to transmission	-	10
Lower stop to Transmission Mount	-	20
Securing the Shift Mechanism to the Body, Nut	-	10
Selector Lever Cable adjustment to the selector mechanism function unit	-	13
Transmission Support to Transmission	-	40
Transmission Support to Transmission Mount Nut	-	20

¹⁾ For bolt tightening clarification, refer to ElsaWeb under *ATF Cooler, ATF Pipes and ATF Filter Overview* and see items -12 and 14-.

Fastener Tightening Specifications – Internal Components

Component	Nm
ATF Drain Plug	45
ATF Fill and Check Plug	45
Transmission Fluid (MTF) Fill and Check Plug	45
Transmission Fluid (MTF) Drain Plug	45

Gears, Shafts – 0B5

Fastener Tightening Specifications

Component	Nm
ATF filter cover to ATF filter housing	8
ATF filter housing to transmission housing	10
ATF pipe connection to transmission housing	10
Cable guide for the RPM sensors to transmission	8
Connector housing to transmission housing	8
Oil pump to transmission housing	25
Retaining plate to ATF pressure pipes	10
Sensor module to transmission intermediate housing	8
Side shaft to transmission intermediate housing (replace)	150 an additional 90° (¼ turn)
Suction jet pump to transmission housing	4.5

ATF Oil Pan Tightening Specifications

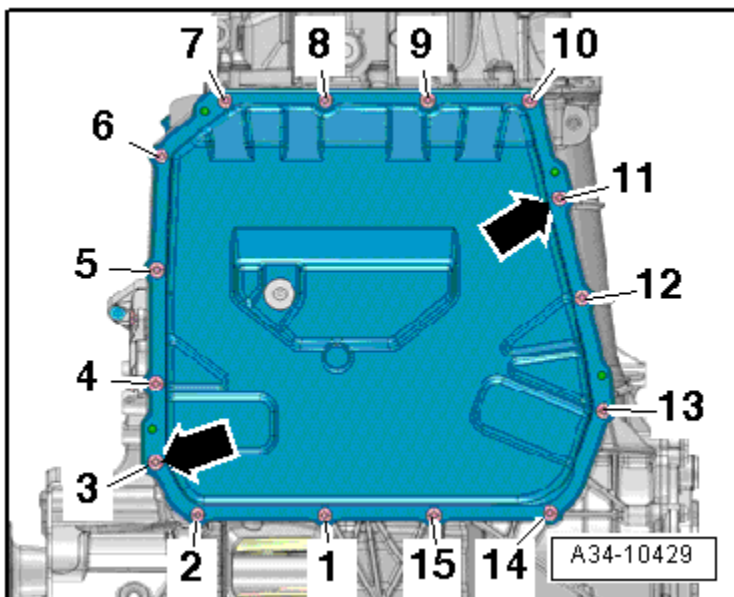

Component	Nm
Install bolts ➡	Hand-tighten
Tighten bolts 1 through 15 diagonally and in steps	10

Mechatronic Tightening Specification

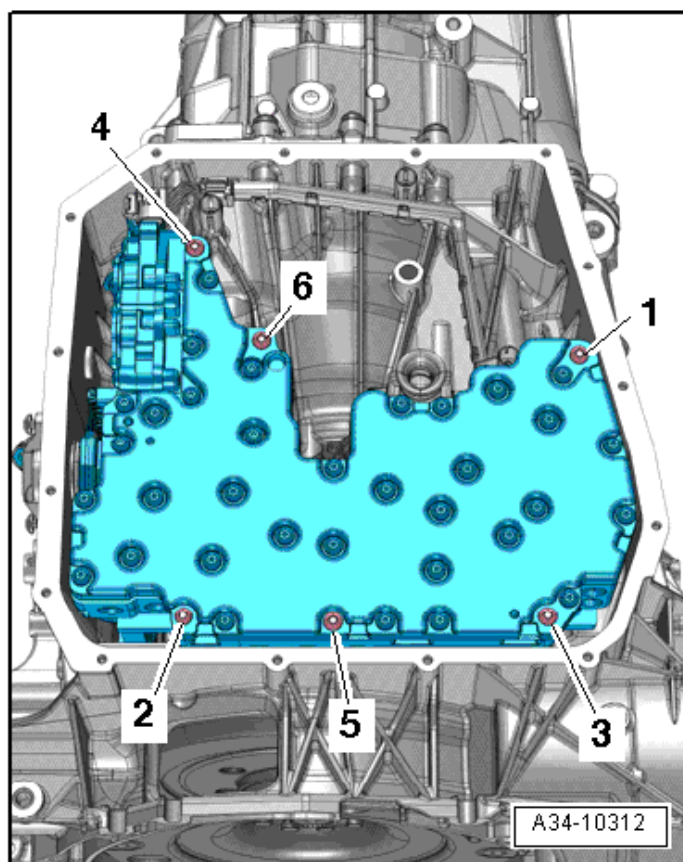

Component	Nm
Tighten bolts 1 through 6 in sequence	10

Circuit Board 1 Tightening Specification

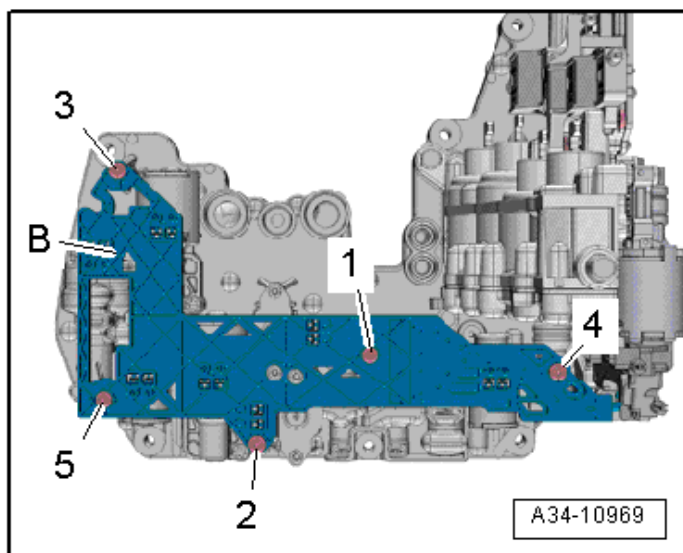

Component	Nm
Tighten bolts 1 through 5 in sequence	3

Circuit Board 2 Tightening Specification

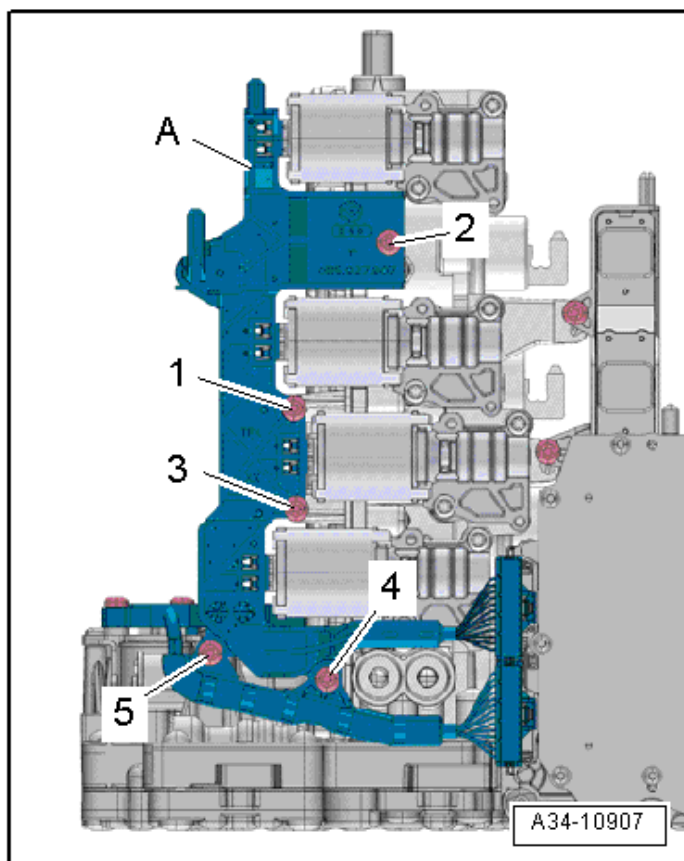

Component	Nm
Tighten bolts 1 through 5 in sequence	3

Transmission Intermediate Housing Tightening Specification

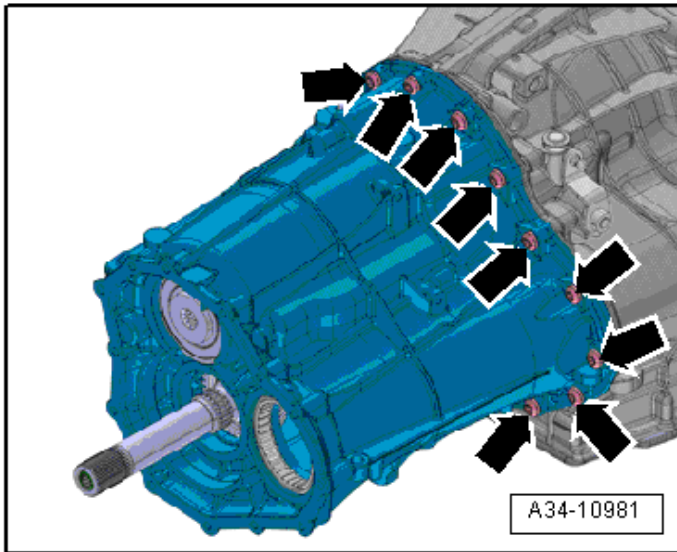

Step	Component	Tightening Specification/Additional Turn
1	-Arrows-	8 Nm diagonally
2	-Arrows-	120° additional turn, diagonally

Rear Final Drive, Differential – 0B5 Fastener Tightening Specifications

Component	Nm
Balance weight to center differential housing	20 an additional 90° (¼ turn)
Bracket to the left flange shaft with the bearing	10 plus an additional 45° (½ turn)
Transmission fluid (MTF) drain plug	45
Transmission fluid (MTF) fill and check plug	45

¹⁾ Replace

Direct Shift Trans.,
S tronic – 0B5

Front Final Drive Cover Tightening Specifications

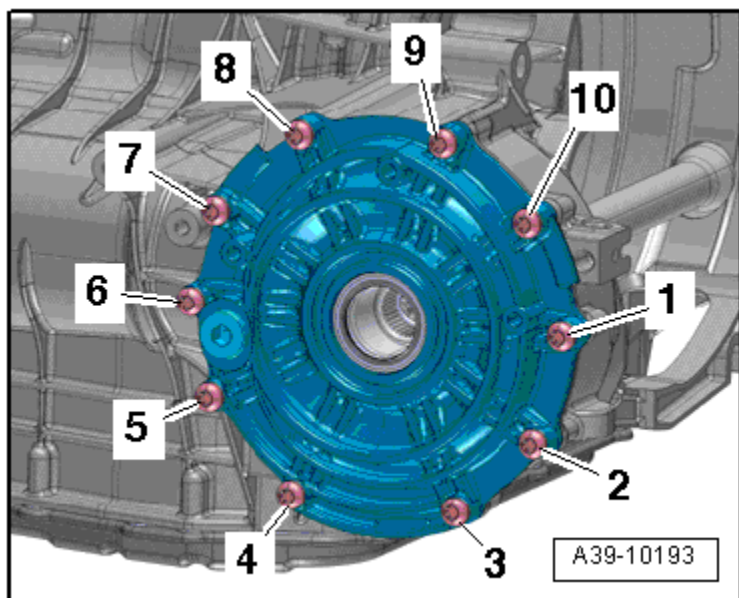

Step	Component	Nm
1	Tighten bolts 1 through 10 in sequence	3
2	Tighten bolts 1 through 10 in sequence	20
3	Tighten bolts 1 through 10 in sequence	an additional 90° (¼ turn)

Center Differential Housing - Attached Driveshaft Tightening Specifications

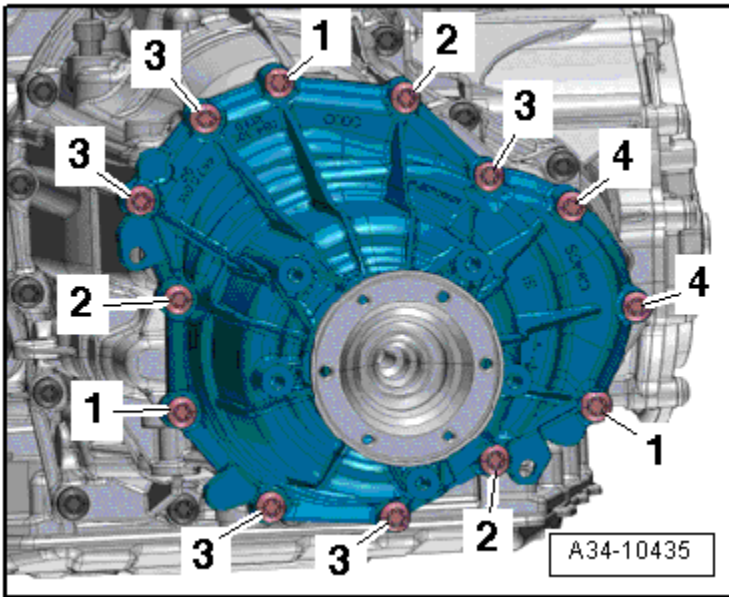

Step	Bolts	Nm
1	Aluminum bolts -1-	8 Nm
2	Aluminum bolts -2-	Tighten the bolt hand-tight.
3	Aluminum bolts -1-	Loosen again and then install all the way hand-tight
4	Aluminum bolts -3-	Tighten the bolt hand-tight.
5	Steel bolts -4-	Tighten the bolt hand-tight.
6	-1, 2, 3, 4-	10 Nm diagonally
7	Steel bolts -4-	15 Nm
8	-1, 2, 3, 4-	90° additional turn, diagonally

**Direct Shift Trans.,
S tronic – 0B5**

Center Differential Housing - Bolted Driveshaft Tightening Specifications

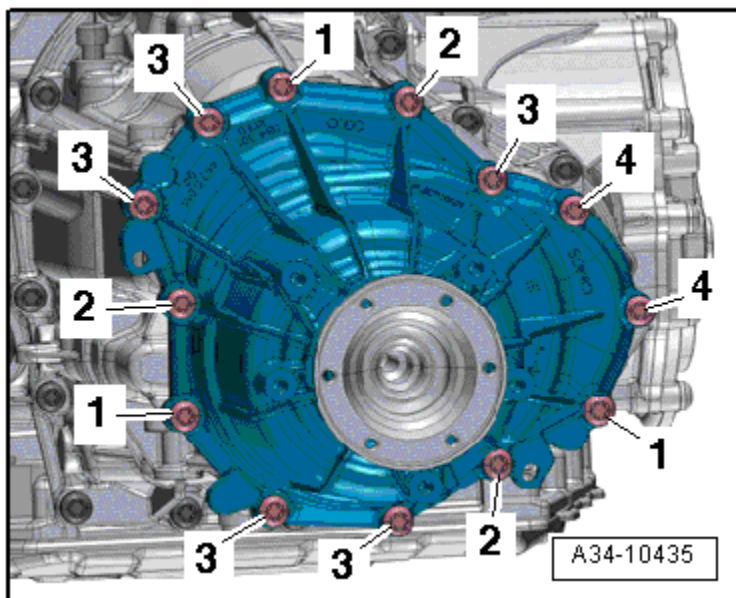

Step	Bolts	Nm
1	Aluminum bolts -1-	8 Nm
2	Aluminum bolts -2-	Tighten the bolt hand-tight.
3	Aluminum bolts -1-	Loosen again and then install all the way hand-tight
4	Aluminum bolts -3-	Tighten the bolt hand-tight.
5	Steel bolts -4-	Tighten the bolt hand-tight.
6	-1, 2, 3, 4-	10 Nm diagonally
7	Steel bolts -4-	15 Nm
8	-1, 2, 3, 4-	90° additional turn, diagonally

CONTINUOUSLY VARIABLE AUTOMATIC TRANSMISSION – 0AW

Transmission Identification

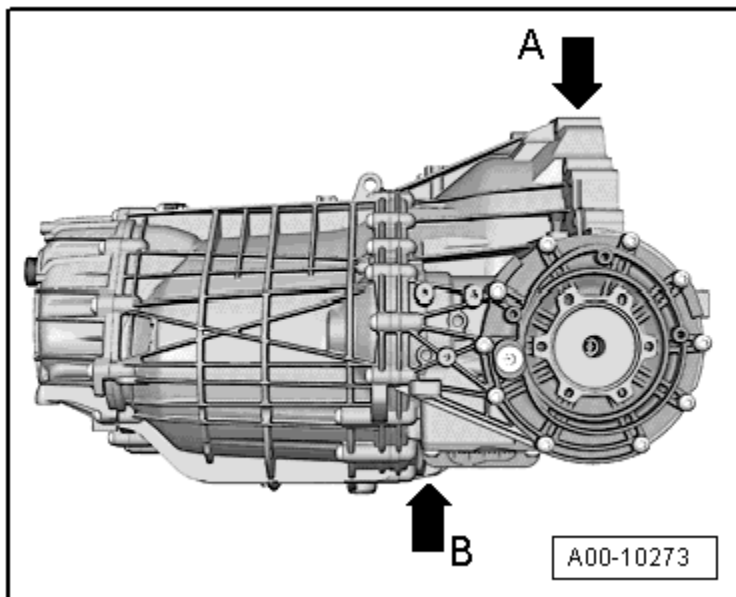

Transmission code letters and serial numbers are found on the top A ➡ and on the bottom B ➡ of the transmission housing.

3X19163		
JQE	C14	164
14		05017

In this example:

- 3X19163 : Transmission identification number
- JQE : Transmission code
- C14: Production line (irrelevant)
- 164 : Serial number
- 14 : Factory (not relevant)
- 05017 : Build date January 5, 2007

Engine Codes, Transmission Allocations, Ratios and Equipment

Multitronic		0AW			
Transmission	Identification codes	LAQ		LKV	
Allocation	Type	Audi A4 from MY 2008		Audi A4 from MY 2008	
	Engine	2.0L TFSI - 155 kW		2.0L TFSI - 155 kW	
Input shaft to disc set 1 ratio		49:48	1.021	49:48	1.021
Disc set 2 to pinion		41:25	1.640	41:25	1.640
Front final drive		34:11	3.091	34:11	3.091

Multitronic		0AW			
Transmission	Identification codes	LKW		LSF	
Allocation	Type	Audi A4 from MY 2008		Audi A4 from MY 2008	
	Engine	2.0L TFSI - 155 kW		2.0L TFSI - 155 kW	
Input shaft to disc set 1 ratio		49:48	1.021	49:48	1.021
Disc set 2 to pinion		41:25	1.640	41:25	1.640
Front final drive		34:11	3.091	34:11	3.091

Multitronic		0AW			
Transmission	Identification codes	MVC			
Allocation	Type	Audi A4 from MY 2008			
	Engine	2.0L TFSI - 155 kW			
Input shaft to disc set 1 ratio		49:48		1.021	
Disc set 2 to pinion		41:25		1.640	
Front final drive		34:11		3.091	

Securing Transmission to Engine

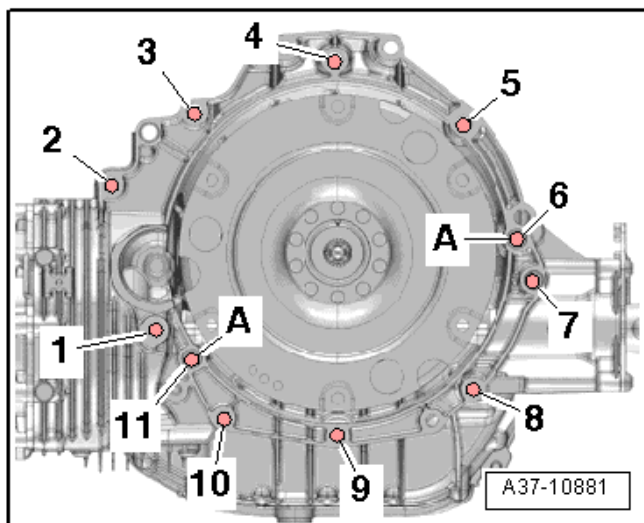

Item	Bolt	Nm
1 ¹⁾	M10 x 50 ²⁾	65
2 ³⁾ , 7	M12 x 100	30 plus an additional 90° (¼ turn)
3, 6	M12 x 75	30 plus an additional 90° (¼ turn)
4, 5	M12 x 120	30 plus an additional 90° (¼ turn)
8, 9, 10	M10 x 75	15 plus an additional 90° (¼ turn)
11	M12 x 50	30 plus an additional 90° (¼ turn)
A	Alignment sleeves for centering	

¹⁾ Also secures the starter.

²⁾ Bolt strength rating 10.9; there is no limit to the number of times steel bolts can be used.

³⁾ The aluminum bolts can be used twice.

Aluminum bolts 2 through 11 can only be used twice. After using the bolts once, use a chisel and mark the bolts with two notches (X). To prevent damaging the bolts when marking them, do not clamp them in a vise. Use a ½" drive 14 mm socket and extension clamped into a vice. Do not use bolts that have been marked with an X.

Controls, Housing – 0AW

Fastener Tightening Specifications

Component	Bolt Size	Nm
Bolts and nuts	M6	9
	M7	15
	M8	20
	M10	40
	M12	65
ATF fill and inspection plug ¹⁾	-	30
ATF filter to transmission	-	5 plus an additional 90° (¼ turn)
ATF pipe return line nuts on pipes	-	29
ATF pipe, return pipe from the ATF cooler to the transmission		8
ATF pipe, return pipe to ATF filter	-	20
ATF pipe, supply from the transmission to the ATF cooler ²⁾	-	5
ATF pipe, supply from the transmission to the ATF cooler ³⁾	-	8
Drive axle heat shield bolt	-	23
Dual-Mass flywheel to drive plate ¹⁾	-	60
Lower stop for the transmission mount	-	20 plus an additional 90° (¼ turn)
Selector lever cable nut	-	13
Selector lever cable adjustment	-	13
Selector lever cable bracket to housing	-	8
Selector mechanism function unit nut	-	10
Transmission mount, nut	-	20
Transmission support		
Bolt	-	40
Nut	-	20
Tunnel crossmember	-	70

¹⁾ Replace bolts.

²⁾ For bolt tightening clarification, refer to ElsaWeb under ATF Pipes, ATF Cooler and ATF Filter Overview, item 3.

³⁾ For bolt tightening clarification, refer to ElsaWeb under ATF Pipes, ATF Cooler and ATF Filter Overview, items 6, 7 and 12.

Gears, Hydraulic Controls – 0AW

Fastener Tightening Specifications

Component	Nm
Cover	10 an additional 90° (¼ turn)
Hydraulic control unit	5 an additional 90° (¼ turn)
Transmission control module	5 an additional 90° (¼ turn)

¹⁾ Replace

Rear Final Drive, Differential – 0AW

Fastener Tightening Specifications

Component	Nm
ATF fill and inspection plug ¹⁾	30
Bracket for the Left Flange Shaft	10 an additional 90° (¼ turn)
Rear Final Drive, Differential ¹⁾	30
Fill and inspection plug for the transmission fluid inside the front final drive ¹⁾	30
Gearshift Lever	10
Hydraulic Control Unit	5 plus an additional 45° (½ turn)
Transmission Control Module	5 plus an additional 45° (½ turn)

¹⁾ Replace

Front Final Drive Cover Tightening Specifications

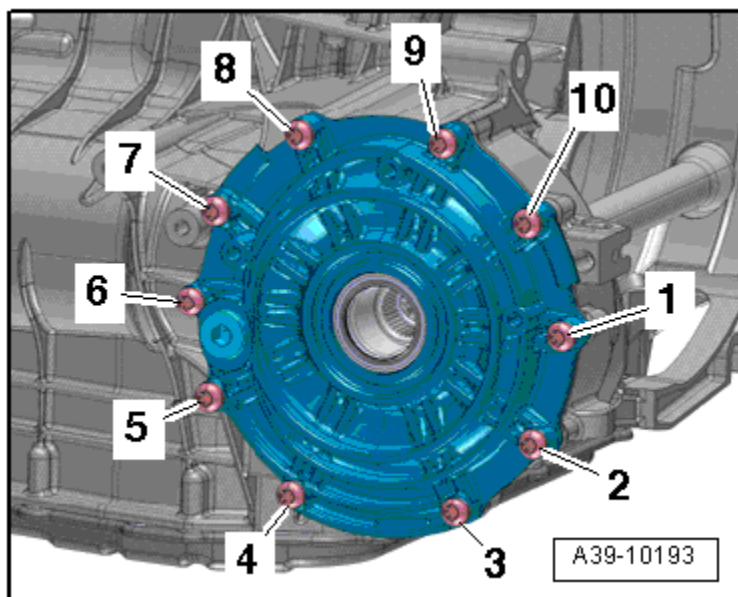

Step	Component	Nm
1	Tighten bolts 1 through 10 in sequence	3
2	Tighten bolts 1 through 10 in sequence	20
3	Tighten bolts 1 through 10 in sequence	an additional 90° (¼ turn)

AUTOMATIC TRANSMISSION – 0BK

Transmission Identification

Auto Trans. – 0BK

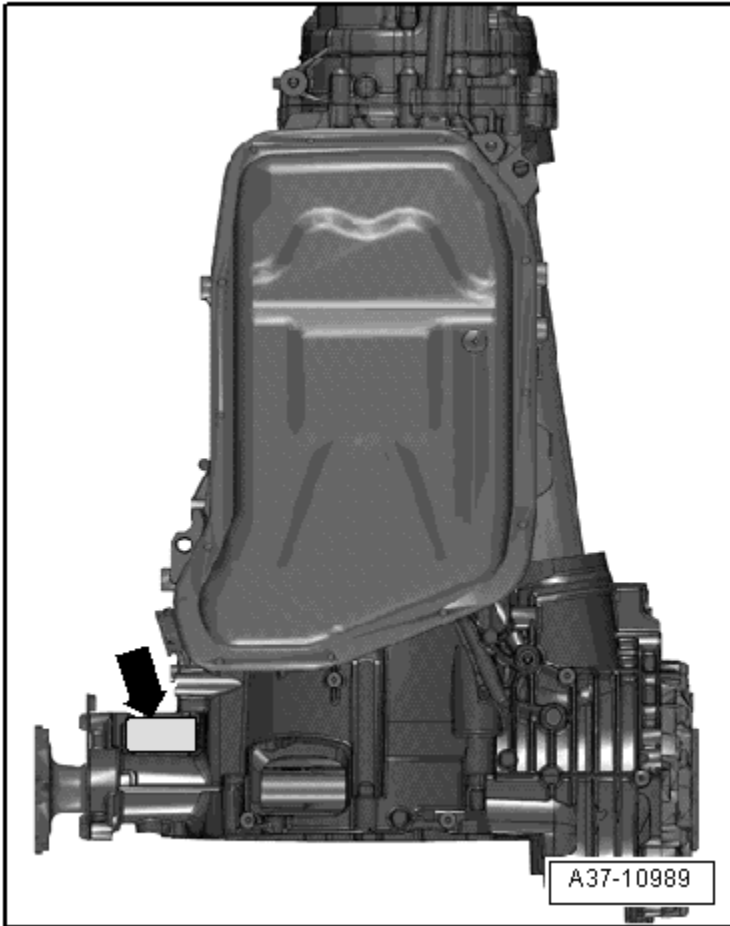

Transmission code letters are located on the data plate under the transmission. Type plate installed location ➔.

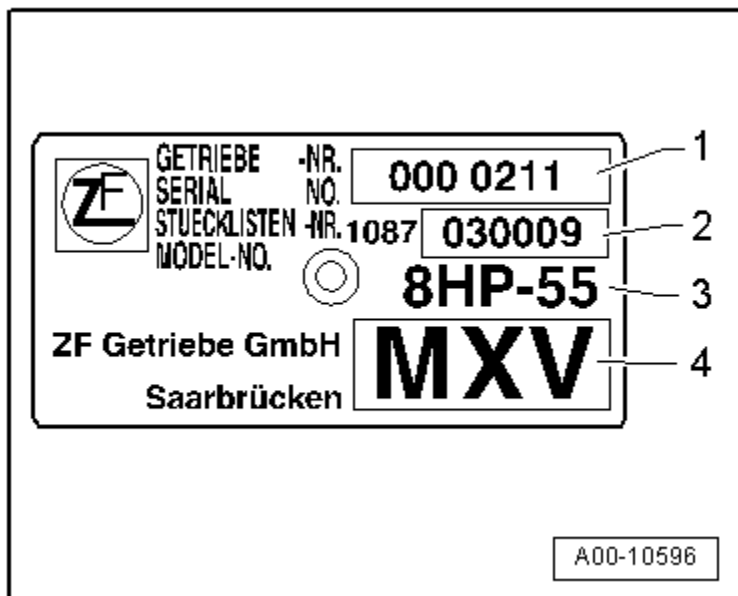

- 1 - Transmission serial number
- 2 - Parts list number
- 3 - Manufacturer transmission identification: 8HP-55
- 4 - Example of a transmission code: MXV

The transmission code letters are also included on the vehicle data labels.

Code Letters, Transmission Allocations, Ratios and Equipment

Automatic Transmission			0BK AWD	
Trans- mission	Identification codes		MXW	NES
	Month of manufacture	from through	06.2010 07.2010	07.2010
Torque converter	Identification codes		NW235	NW235
Allocation	Type		Audi A4 from MY 2008	Audi A4 from MY 2008
	Engine		2.0L TFSI - 155 kW	2.0L TFSI - 155 kW
Primary drive			25:29 = 0.862	25:29 = 0.862
Gear wheel, front axle			31:29 = 1.069	31:29 = 1.069
Front axle bevel gear			34:11 = 3.091	34:11 = 3.091
Complete front axle ratio = primary drive x drive wheel x bevel gear			2.848	2.848
Rear axle bevel gear			43:13 = 3.308	43:13 = 3.308
Complete rear axle ratio = rear axle bevel gear x primary drive			2.851	2.851
Oil system, front final drive/ transfer case			Separated	Separated

Controls, Housing – 0BK

Securing Transmission to Engine

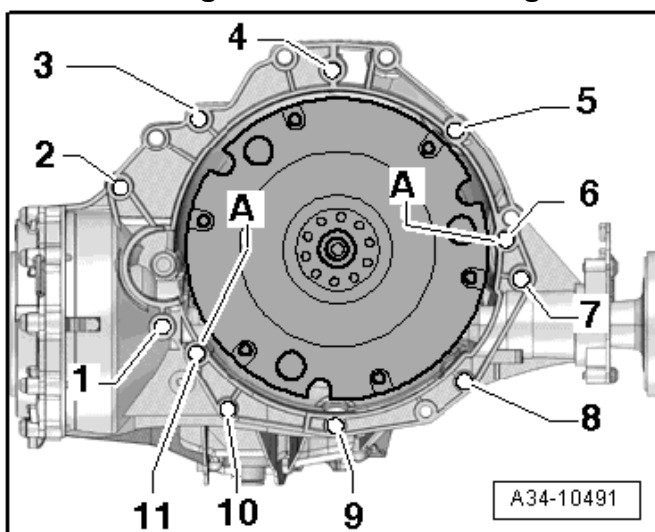

Item	Bolt	Nm
1 ¹⁾	M10 x 50 ²⁾	65
2 ¹⁾ , 7	M12 x 100 ³⁾	30 plus an additional 90° (¼ turn)
3 ⁴⁾ , 6	M12 x 75 ³⁾	30 plus an additional 90° (¼ turn)
4, 5 ⁴⁾	M12 x 120 ³⁾	15 plus an additional 90° (¼ turn)
8, 10	M10 x 75 ³⁾	15 plus an additional 90° (¼ turn)
9	M10 x 60 ³⁾	15 plus an additional 90° (¼ turn)
11 ⁵⁾	M12 x 50 ³⁾	30 plus an additional 90° (¼ turn)
A	Alignment sleeves for centering	

¹⁾ Also secures the starter.

²⁾ Bolt strength rating 10.9, there is no limit to the number of times steel bolts can be used.

³⁾ The aluminum bolts can be used twice.

⁴⁾ With a bracket for the wires.

⁵⁾ Installed from the engine side.

Aluminum bolts 2 through 11 can only be used twice. After using the bolts once, use a chisel and mark the bolts with two notches (X). To prevent damaging the bolts when marking them, do not clamp them in a vise. Use a ½" drive 14 mm socket and extension clamped into a vise. Do not use bolts that have been marked with an X.

Fastener Tightening Specifications

Component	Bolt Size	Nm
ATF drain plug (always replace)	-	12
ATF pipe, nut	-	29
ATF plug for the hole for checking and filling (always replace)	-	30
Bolts and nuts	M6	9
	M7	15
	M8	20
	M10	40
	M12	65
Drain plug for the hole for checking and filling the transmission fluid inside the transfer case	-	27
Drain plug for the hole for checking and filling the transmission fluid inside the front final drive	-	27
Drive axle heat shield	-	23
Oil drain plug for the transmission fluid inside the transfer case	-	12
Oil drain plug for the transmission fluid inside the front final drive	-	10
Selector mechanism function unit to the body, nut	-	10

Gears, Hydraulic Controls – 0BK

Fastener Tightening Specifications

Component	Nm
Mechatronic connector-to-transmission housing	10
Transmission output speed sensor-to-transmission housing	10

ATF Oil Pan Tightening Specifications

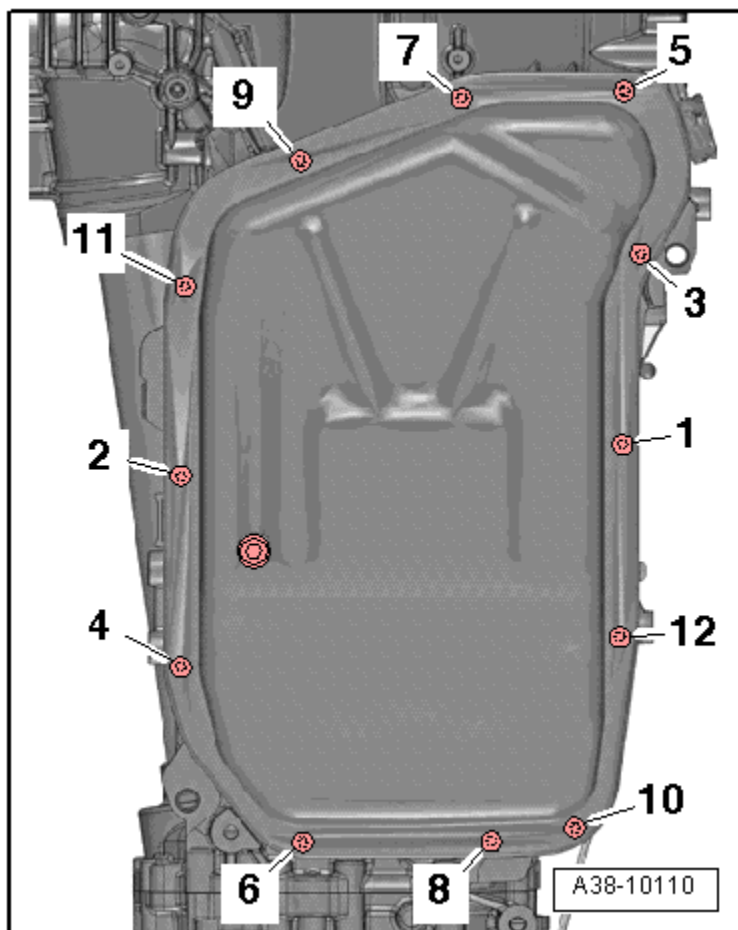

Stage	Bolts	Tightening Specification/Additional Turn
1	1 through 12	Hand-tighten until the bolt heads touch
2	1 through 12	4
3	1 through 12	an additional 45° (½ turn)

Mechatronic Tightening Specification

Auto Trans. – 0BK

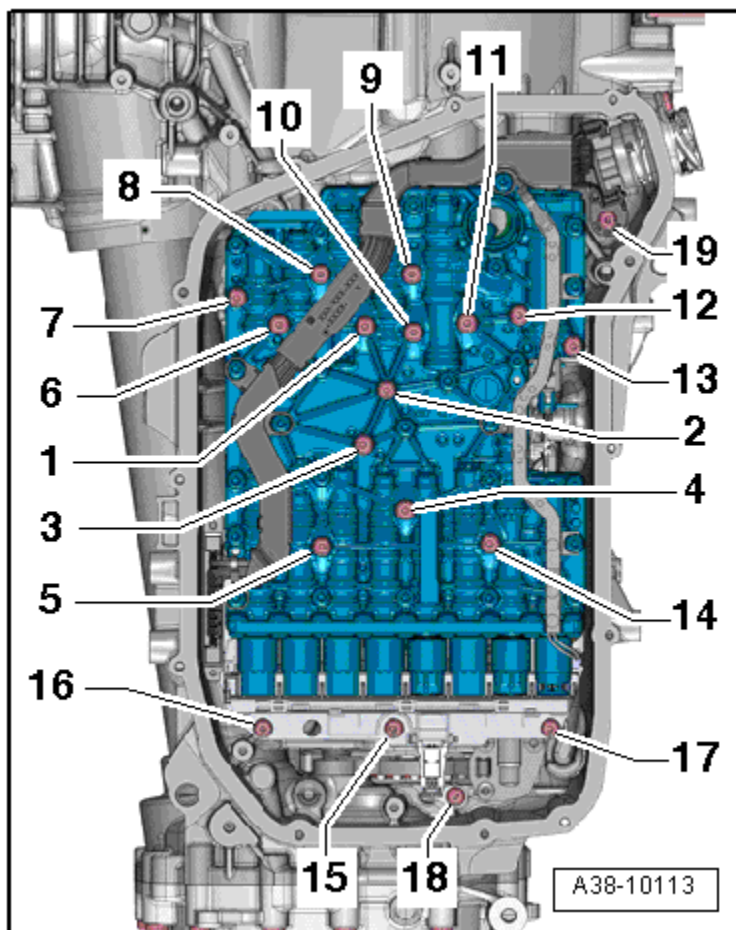

Component	Nm
Tighten bolts 1 through 19 in sequence	10

Rear Final Drive, Differential – 0BK

Fastener Tightening Specifications

Component	Nm
Drain Plug	27
Oil Drain Plug for the Transmission Fluid Inside the Front Final Drive	10
Oil Drain Plug for the Transmission Fluid Inside the Transfer Case	12

Front Final Drive Cover Tightening Specifications

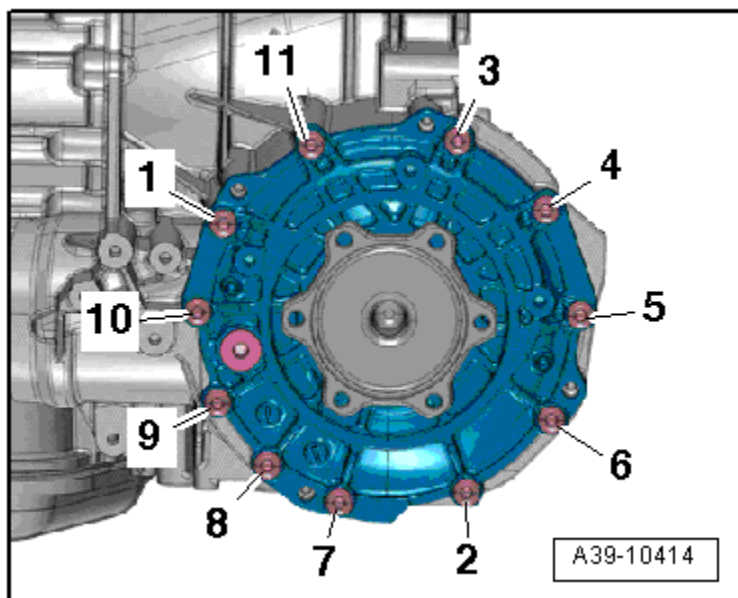

Stage	Bolts	Nm
1	1 and 6	3
2	1 through 11	27

Center Differential Housing Tightening Specification

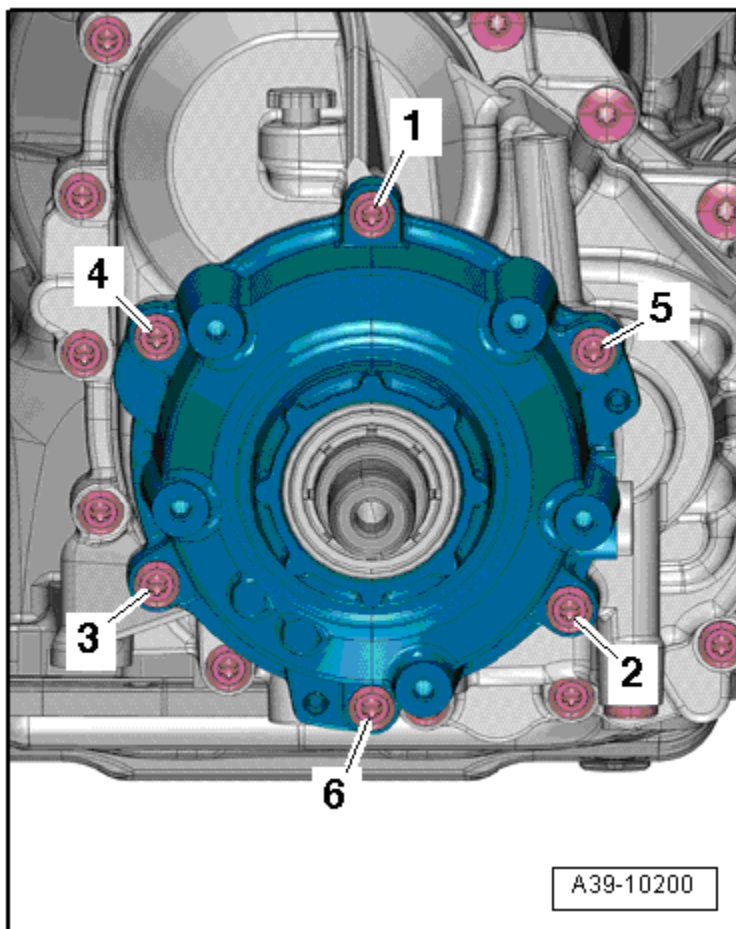

Replace the center differential housing bolts.

Stage	Bolts	Nm
1	1 and 6	3
2	1 through 6	10
3	1 through 6	an additional 90° (¼ turn)

REAR FINAL DRIVE – 0BC, 0BD, 0BE, 0BF

General, Technical Data – 0BC

Rear Final Drive Identification

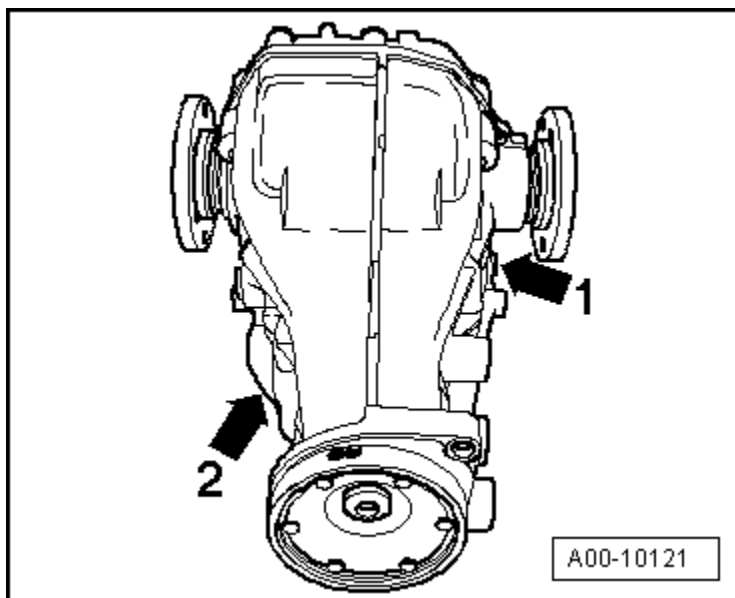

0BC final drive and 0AR (1➡). Code and build date (2➡).

Final Drive Identification

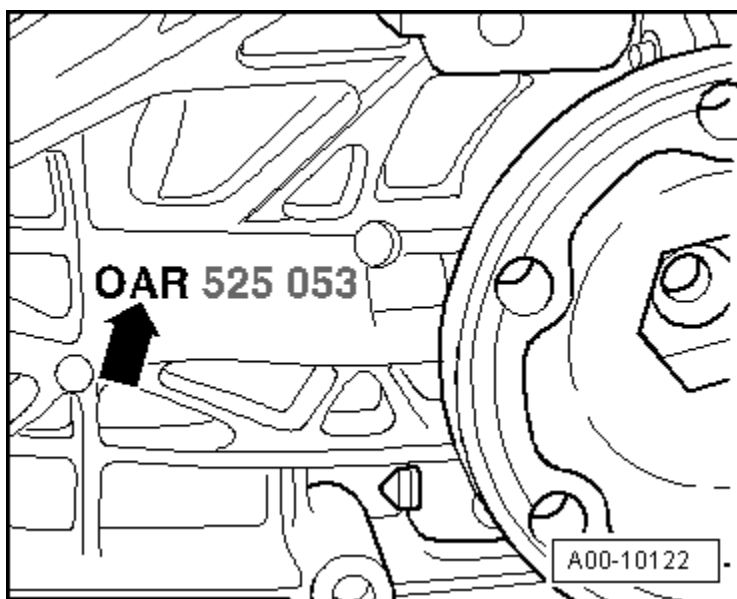

Rear Final Drive –
0BC, 0BD, 0BE, 0BF

Final Drive 0BC (➡) and 0AR

Note: 0AR is always on the rear final drive housing. The changes to the housing are what differentiate the 0BC final drive from the 0AR final drive.

Final Drive Identification (cont'd)

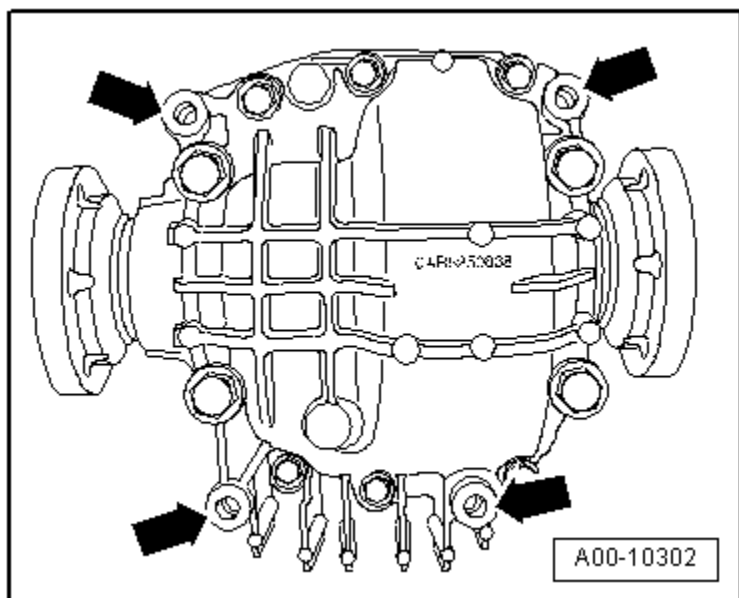

The locations of the threaded holes (➡) for attaching the cross member to the rear final drive are also different.

The 0BC final drive has 4 threaded holes (➡) in its housing, used for attaching the cross member. In addition to this, there is an additional threaded hole under the flange/driveshaft used for attaching the final drive to the subframe.

Rear Final Drive Code and Date of Manufacture

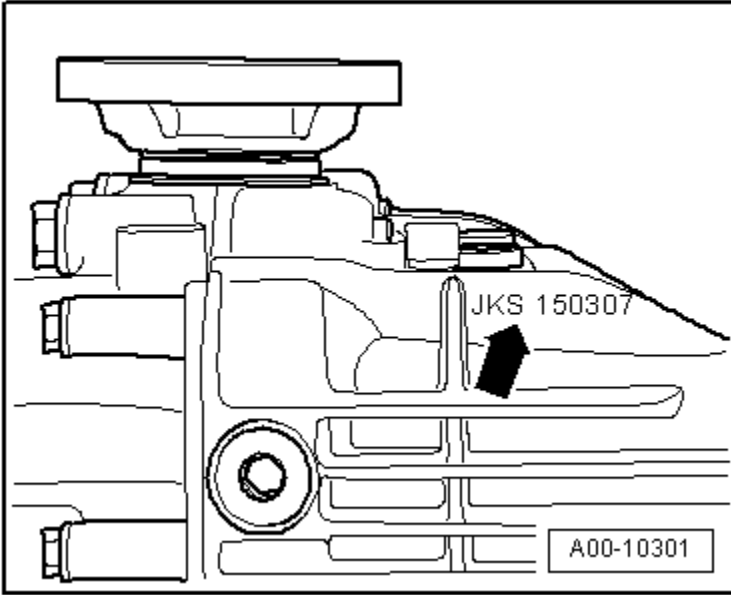

**Rear Final Drive –
0BC, 0BD, 0BE, 0BF**

Example:	JKS	15	03	07
	Code letters	Day	Month	Year of manufacture 2007

When installing a new rear final drive unit, the final drive code, the PR number and the vehicle engine code must be verified in the Parts Catalog. This is the only to assure the correct allocation.

General, Technical Data – 0BD

Rear Final Drive Identification

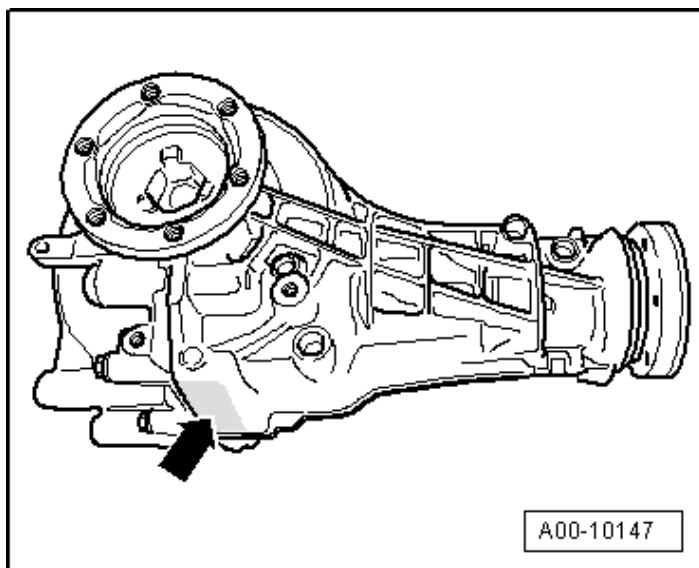

Final drive OBD, code letters and manufacture date (➡).

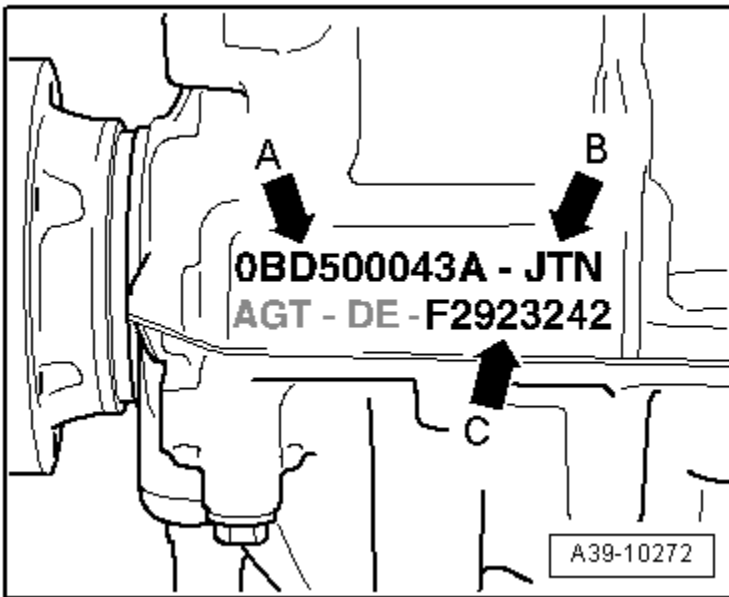

Rear Final Drive –
0BC, 0BD, 0BE, 0BF

A ➔ front final drive OBD with replacement part number (example: 0BD 500 043A)

B ➔ code letters JTN

C ➔ Rear final drive manufacture date

Example

F	292	3242
Production year 2006 F = 2006, G = 2007, H = 2008, etc.	Production date 292 nd calendar day (always given in three-digit format)	Day of manufacture serial number

General, Technical Data – 0BE, 0BF

Rear Final Drive Identification

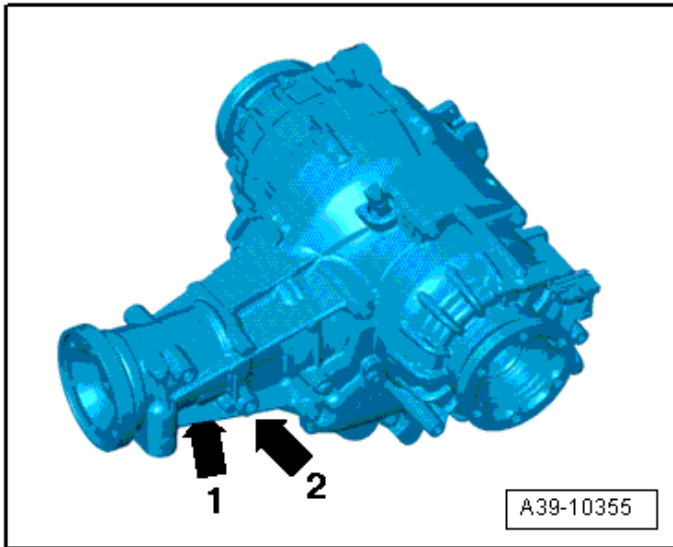

Clutch class -arrow 1-. Engine code and build date-arrow 2-. The way to recognize the rear final drive “0BF and 0BE” is the hydraulic control unit with the side chambers.

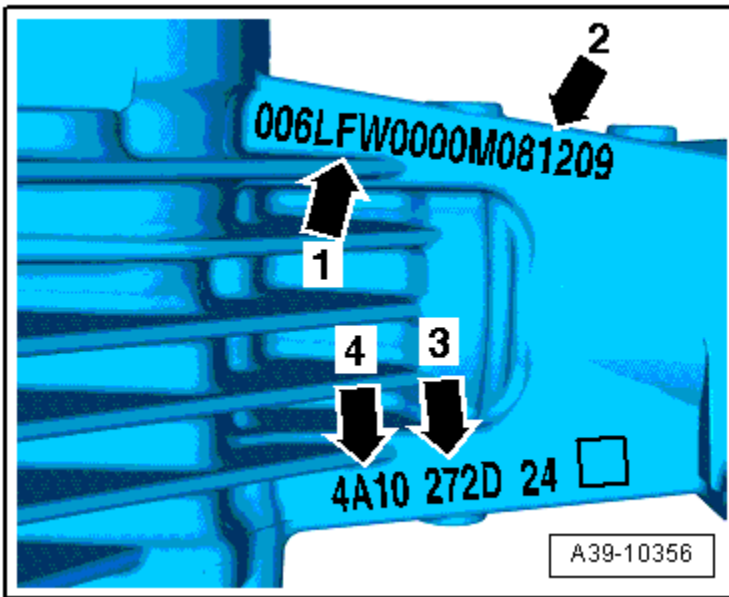

Rear Final Drive –
0BC, 0BD, 0BE, 0BF

1 ➔ Code LFW

2 ➔ Rear final drive build dates

3 ➔ Classification (classification of the clutch wear values) for the right clutch. Example: -272D-

4 ➔ Classification (classification of the clutch wear values) for the left clutch. Example: -4A10-

Example

08	12	09
Production year 2008	Month	Day

Rear Final Drive 0BC Transmission Allocations, Ratios, Capacities

Rear Final Drive		0BC		
Code letters		JKS	JKQ	JKR
Ratio	Final drive $Z_2:Z_1$	37:10 = 3.700	37:10 = 3.700	37:9 = 4.111
Driveshaft flange diameter		70.7 mm	75.5 mm	70.7 mm
Gear oil capacity		See the Fluid Capacity Tables; Rep. Gr.03		

Rear Final Drive		0BC		
Code letters		JKS	KCC	KLL
Ratio	Final drive $Z_2:Z_1$	35:9 = 3.889	43:13 = 3.308	35:8 = 4.375
Driveshaft flange diameter		75.5 mm	75.5 mm	70.7 mm
Gear oil capacity		See the Fluid Capacity Tables; Rep. Gr.03		

Rear Final Drive		0BC	
Code letters		LYF	MNA
Ratio	Final drive $Z_2:Z_1$	37:9 = 4.111	37:9 = 4.111
Driveshaft flange diameter		70.7 mm	70.7 mm
Gear oil capacity		See the Fluid Capacity Tables; Rep. Gr.03	

Rear Final Drive		0BC	
Code letters		MNB	NPR
Ratio	Final drive $Z_2:Z_1$	37:9 = 4.111	43:13 = 3.308
Driveshaft flange diameter		75.5 mm	75.5 mm
Gear oil capacity		See the Fluid Capacity Tables; Rep. Gr.03	

Rear Final Drive 0BD Transmission Allocations, Ratios, Capacities

Rear Final Drive		0BD	
Code letters		JTN	KBU
Ratio	Final drive $Z_2:Z_1$	35:8 = 4.375	43:13 = 3.308
Driveshaft flange diameter		70.7 mm	70.7 mm
Gear oil - capacity		See the Fluid Capacity Tables; Rep. Gr.03;	
ATF specification		Refer to the Parts Catalog.	

Rear Final Drive OBF Transmission Allocations, Ratios, Capacities

Rear Final Drive		OBF		
Code letters		LFU	LFV	LFW
Ratio	Final drive $Z_2:Z_1$	35:9 = 3.889	37:9 = 4.111	43:13 = 3.308
Driveshaft flange diameter		75.5 mm	75.5 mm	75.5 mm
Gear oil capacity for the final drive (differential and pinion). No change interval.		→ Fluid Capacity Tables; Rep. Gr.03;		
Gear oil specification		Refer to the Parts Catalog		
ATF capacity for the hydraulic control unit and chambers. No change interval.		→ Fluid Capacity Tables; Rep. Gr.03;		
ATF specification		Refer to the Parts Catalog		

**Rear Final Drive –
OBC, OBD, OBE, OBF**

Rear Final Drive		OBF		
Code letters		LGH	LGJ	MBV
Ratio	Final drive $Z_2:Z_1$	37:10 = 3.700	35:8 = 4.375	35:9 = 3.889
Driveshaft flange diameter		75.5 mm	75.5 mm	75.5 mm
Gear oil capacity for the final drive (differential and pinion). No change interval.		→ Fluid Capacity Tables; Rep. Gr.03;		
Gear oil specification		Refer to the Parts Catalog		
ATF capacity for the hydraulic control unit and chambers. No change interval.		→ Fluid Capacity Tables; Rep. Gr.03;		
ATF specification		Refer to the Parts Catalog		

Rear Final Drive 0BF Transmission Allocations, Ratios, Capacities (cont'd)

Rear Final Drive		0BF		
Code letters		MBW	MKU	MKV
Ratio	Final drive $Z_2:Z_1$	37:10 = 3.700	37:9 = 4.111	43:13 = 3.308
Driveshaft flange diameter		75.5 mm	75.5 mm	75.5 mm
Gear oil capacity for the final drive (differential and pinion). No change interval.		→ Fluid Capacity Tables; Rep. Gr.03;		
Gear oil specification		Refer to the Parts Catalog		
ATF capacity for the hydraulic control unit and chambers. No change interval.		→ Fluid Capacity Tables; Rep. Gr.03;		
ATF specification		Refer to the Parts Catalog		

Rear Final Drive		0BF		
Code letters		MKW	MKX	MKY
Ratio	Final drive $Z_2:Z_1$	35:8 = 4.375	35:9 = 3.889	37:10 = 3.700
Driveshaft flange diameter		75.5 mm	75.5 mm	75.5 mm
Gear oil capacity for the final drive (differential and pinion). No change interval.		→ Fluid Capacity Tables; Rep. Gr.03;		
Gear oil specification		Refer to the Parts Catalog		
ATF capacity for the hydraulic control unit and chambers. No change interval.		→ Fluid Capacity Tables; Rep. Gr.03;		
ATF specification		Refer to the Parts Catalog		

The following information can be found in the Electronic Parts Catalog (ETKA):

- Date of manufacture
- Gear oil specification
- Engine, manual transmission and automatic transmission allocation using code letters and PR numbers.

Fastener Tightening Specifications

Component	-Fastener Size	Nm
Driveshaft heat shield	-	24
Intermediate bearing bracket	-	20
Lock plate to driveshaft ¹⁾	-	30 plus an additional 90° (¼ turn)
Final Drive 0BC, 0BD		
Balance weight to rear final drive bolt ³⁾	-	22
Balance weight to rear final drive bolt ⁴⁾	-	55
Crossmember to rear final drive bolt	-	55
Heat shield to crossmember bolt	-	20
Subframe ²⁾		
- Bolt	-	55
- Bolt	-	95
Gear Oil Drain and Inspection Plugs 0BE, 0BF		
Drain plug for gear oil ¹⁾	-	15
Inspection plug for gear oil ¹⁾	-	15
Final Drive 0BE, 0BF		
All Wheel Drive Clutch Valve 2 -N446- to hydraulic control unit housing bolt	-	2.5
All Wheel Drive Pump -V415- to hydraulic control unit housing bolt	-	5
ATF check plug ¹⁾	-	15
ATF drain plug ¹⁾	-	15
Bracket for wiring harness to rear final drive bolt	-	9
Gear oil drain plug ¹⁾		15
Gear oil inspection plug ¹⁾		15
Gear oil checking plug 0BC		30
Gear oil checking plug 0BD		45
Hydraulic control unit ⁶⁾		
- Bolt ⁵⁾	M8 x 50	20
- Bolt	M8 x 30	see tightening sequence → Hydraulic Control Module, 0BE, 0BF
Left line to Hydraulic Control Unit Housing nut		30
Oil Pressure/Temperature Sensor		10
Right Flange Shaft to Final Drive bolt ¹⁾		50 + 90°
Right line to Hydraulic Control Unit Housing nut		30

**Rear Final Drive –
0BC, 0BD, 0BE, 0BF**

Fastener Tightening Specifications (cont'd)

Component	-Fastener Size	Nm
Shuttle valve		8
Gear Oil Drain and Inspection Plugs, 0BE, 0BF		
ATF drain plug ¹⁾		15
ATF inspection plug ¹⁾		15

¹⁾ Replace

²⁾ For bolt tightening clarification, refer to ElsaWeb, *Final Drive 0BC, 0BD Overview* items 2 and 3

³⁾ For bolt tightening clarification, refer to ElsaWeb, *Final Drive 0BC, 0BD Overview* item 1

⁴⁾ For bolt tightening clarification, refer to ElsaWeb, *Final Drive 0BC, 0BD Overview* item 9

⁵⁾ Coat the thread with Sealing Compound -D 176 501 A1-

⁶⁾ For bolt tightening clarification, refer to ElsaWeb, *Final Drive 0BE, 0BF Overview* items 7, 8 and 9

Driveshaft to Rear Final Drive Tightening Specification

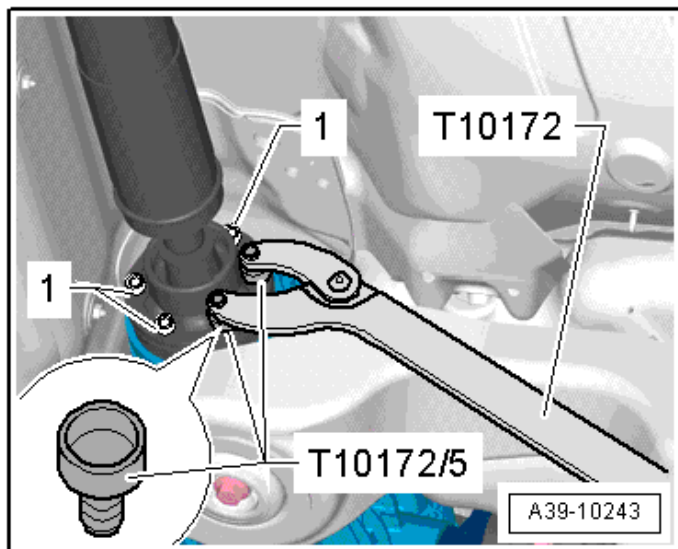

Always replace the driveshaft bolts 1.

Step	Bolts	Tightening Specification/Additional Turn
1	1	Next to the color dot 30 Nm ¹⁾
2	1	30 Nm
3	1	Plus an additional 90° (¼ turn)

¹⁾ By doing this, the CV joint is pushed slightly to the opposite side and imbalance is avoided.

SUSPENSION, WHEELS, STEERING

General Specifications

Chassis

Front axle	Five-link - front axle, upper and lower transverse link, transverse stabilizer, twin gas-filled strut
Rear axle	Track controlled axle, upper and lower transverse links, transverse stabilizer, individual wheel suspension, twin gas-filled struts with coil spring

Steering

Hydraulic Steering Gear

Steering Gear	Steering Gear Maintenance-free rack-and-pinion steering with servo assist
Turning diameter	Approximately 11.40 meters

Electro-Mechanical Steering Gear

Steering Gear	Electro-mechanically assisted, maintenance-free rack-and-pinion steering
Turning diameter	Approximately 11.40 meters

Front Suspension

Front Axle – Curb Weight Data

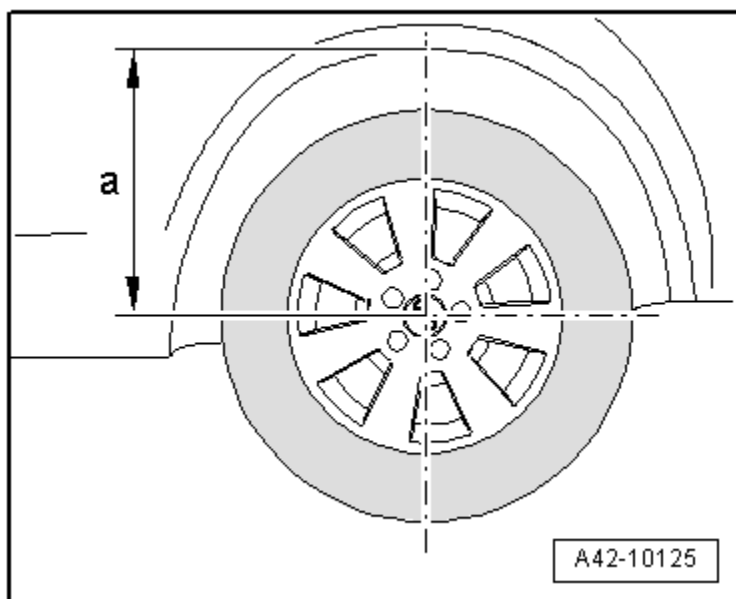

Before starting work, use a tape measure and measure dimension a from wheel center to lower edge of wheel housing. Take this measurement with suspension in curb weight position (vehicle unladen).

FWD/AWD		Standard suspension 1BA Anmerkung	China City suspension 1BB Anmerkung	Sport suspension 1BD Anmerkung	allroad steel spring suspension 1BP Anmerkung
Wheelbase	mm	Approx. 2812	Approx. 2873	Approx. 2815	Approx. 2809
Front track	mm	Approx. 1567	Approx. 1567	Approx. 1569	Approx. 1588
Rear track	mm	Approx. 1557	Approx. 1557	Approx. 1558	Approx. 1581
Maximum steering angle at curved inner wheel	Degree	39° 57'	39° 57'	39° 57'	39° 57'

- The specified values apply to all engine versions.
- Tracks change with use of wheels with different offset.

FWD/AWD		Sport Suspension 1BE Anmerkung	Chassis with Electronic Damping 1BL Anmerkung	Heavy Duty Suspension 1BR Anmerkung	Sport Chassis (S-Line) 1BV Anmerkung
Wheelbase	mm	Approx. 2815	Approx. 2815	Approx. 2811	Approx. 2815
Front track	mm	Approx. 1569	Approx. 1569	Approx. 1565	Approx. 1569
Rear track	mm	Approx. 1558	Approx. 1558	Approx. 1556	Approx. 1558
Maximum steering angle at curved inner wheel	Degree	39° 57'	39° 57'	39° 57'	39° 57'

Front Suspension

Fastener Tightening Specifications

Component	Bolt Size	Nm
Ball joint to lower control arm nut (always replace)		
Combination nut, wrench 18 mm	M12	110
Combination nut, wrench 21 mm	M12	120
Combination nut	M14	140
Collar nut	M12	145
Ball joint-to-wheel bearing housing bolt (always replace)	-	40
Body acceleration sensor nut	-	5
Brake shield-to-wheel bearing housing bolt	-	10
Coupling rod-to-shock absorber fork bolt ⁴⁾	-	40 plus an additional 90° (¼ turn)
Coupling rod-to-stabilizer bar bolt ⁴⁾	-	40 plus an additional 90° (¼ turn)
Cover to subframe bolt		20
CV joint boot clamp, stainless steel		20
Diagonal brace bolt, cabriolet ¹⁾⁴⁾		50 plus an additional 90° (¼ turn)
Drive axle-to-transmission flange bolt (always replace)	-	70

Fastener Tightening Specifications (cont'd)

Component	Bolt Size	Nm
Drive axle-to-wheel hub bolt (always replace)	-	200 plus an additional 180° (½ turn)
Guide link-to-subframe nut ⁴⁾	-	70 plus an additional 180° (½ turn)
Guide link to wheel bearing housing nut ⁴⁾		
- Collar nut, wrench 21 mm	M12	145
- Combination nut, wrench 18 mm	M12	110
- Combination nut, wrench 21 mm	M12	120
- Combination nut, wrench 21 mm	M14	140
Level control system sensor bolt	-	20
Level control system sensor to track control arm nut	-	9
Stabilizer bar-to-subframe nut ⁴⁾	-	25
Subframe crossbrace to subframe bolt, from 09.2007 ⁴⁾		
- On vehicles with electromechanical power steering	-	90 plus an additional 90° (¼ turn)
- On vehicles with hydraulic power steering	-	90 plus an additional 135° turn
- Cabriolet	-	24
Subframe-to-body bolt (always replace)	-	115 plus an additional 90° (¼ turn)
Subframe shield to subframe bolt, from 09.2007	-	9
	-	20
Suspension strut to mounting bracket nut ⁴⁾	-	50
Suspension strut-to-shock absorber fork nut ⁴⁾	-	40 plus an additional 180° (½ turn)
Tie rod-to-wheel bearing housing nut (always replace)		
Collar nut	-	20 Nm plus an additional 90° (¼ turn)
12-point combi nut	-	100
Hex combi nut	-	110
Tower brace bolt	-	7
Tower brace nut	-	30
Track control arm to shock absorber fork nut ^{1) 4)}	-	90 plus an additional 90° (¼ turn)

Component	Bolt Size	Nm
Track control arm to subframe nut ^{1) 4)}		70 plus an additional 180° (½ turn)
Upper control arm-to-suspension strut bolt (always replace) ¹⁾	-	50 plus an additional 90° (¼ turn)
Upper control arm-to-wheel bearing housing nut ⁴⁾	-	40
Wheel bearing and hub-to-wheel bearing housing bolt ⁴⁾	-	80 plus an additional 90° (¼ turn)
Wheel speed sensor-to-wheel bearing housing bolt	-	9

- ¹⁾ Must be tightened in the curb weight position. refer to ElsaWeb under *Wheel Bearing, with Coil Spring, Lifting to Curb Weight Position*.
- ²⁾ For bolt tightening clarification, refer to ElsaWeb under *Subframe, Crossbrace, Stabilizer Bar, Coupling Rod and Subframe Shield Overview* and see items -21 and 22-.
- ³⁾ Pre-tighten to 5 Nm.
- ⁴⁾ Always replace after removal.

Rear Suspension

Fastener Tightening Specifications

Component	Nm
ABS wheel speed sensor bolt	9
Brake disc to wheel hub bolt	5
Brake shield-to-wheel bearing housing bolt	10
Coupling rod to lower transverse link bolt ^{1) 2)}	40 plus an additional 90° (¼ turn)
Coupling rod-to-stabilizer bar bolt ^{1) 2)}	40 plus an additional 90° (¼ turn)
CV joint clamp	20
Drive axle inner CV joint cover bolt ¹⁾	
- 88 mm outer constant velocity joint and 100 mm inner constant velocity joint	20 plus an additional 90° (¼ turn)
- 100 mm outer constant velocity joint and 108 mm inner constant velocity joint	70
- 89/98 mm diameter outer CV joint and 100/108 mm diameter inner CV joint	70

Fastener Tightening Specifications (cont'd)

Component	Nm
Drive axle-to-wheel hub bolt, AWD ¹⁾	200 plus an additional 180° (½ turn)
Diagonal brace to body bolt, cabriolet ^{1) 3)}	50 plus an additional 90° (¼ turn)
Left rear level control system sensor-to-body bolt	5
Left rear level control system sensor-to-lower transverse link bolt	9
Lower transverse link-to-subframe bolt ^{1) 2)}	70 plus an additional 180° (½ turn)
Lower transverse link-to-wheel bearing housing nut ^{1) 2)}	120 plus an additional 360° (full turn)
Securing clip	5
Shock absorber-to-upper shock absorber mount bolt ¹⁾	35
Shock absorber-to-wheel bearing housing bolt ^{1) 2)}	150 plus an additional 180° (½ turn)
Stabilizer bar-to-subframe bolt ¹⁾	25 plus an additional 90° (¼ turn)
Subframe-to-body bolt ^{1) 2)}	115 plus an additional 90° (¼ turn)
Subframe support bolt	55
Tie rod-to-subframe nut ^{1) 2)}	95
Tie rod-to-wheel bearing housing bolt ^{1) 2)}	90 plus an additional 90° (¼ turn)
Upper shock absorber mount-to-body bolt ¹⁾	50 plus an additional 45° (⅙ turn)
Upper transverse link-to-subframe bolt ^{1) 2)}	95
Upper transverse link-to-wheel bearing housing nut ^{1) 2)}	70 plus an additional 180° (½ turn)
Wheel bearing unit-to-wheel bearing housing bolt, AWD ¹⁾	80 plus an additional 90° (¼ turn)

Component	Nm
Wheel bearing unit-to-wheel bearing housing bolt, FWD ¹⁾	200 plus an additional 180° (½ turn)

¹⁾ Always replace after removal.

²⁾ Must be tightened in the curb weight position. Refer to ElsaWeb under Wheel Bearing, with Coil Spring, Lifting to Curb Weight Position.

³⁾ Pre-tightening to 5 Nm

Self-Leveling Suspension

Fastener Tightening Specifications

Component	Nm
Central valve to bracket bolt	20
Central valve bracket bolt	20
Connection to the front suspension strut	14
Dynamic Ride Control (DRC) line to the rear shock absorber	14
Electronic damping control module nut	2
Front body acceleration sensor nut	5
Rear body acceleration sensor bolt	5
Shut-off valve	5
Shut-off valve locking nut	12

Wheels, Tires, Wheel Alignment

Fastener Tightening Specifications

Component	Nm
Adaptive cruise control sensor assembly bracket bolt	8
Level control system control module bracket and ground wire nut	6
Level control system control module-to-bracket bolt	8
Tire pressure monitoring control module nut	2
Tire pressure monitoring sensor union nut	8
Decorative trim-to-wheel rim bolt	5
Wheel electronics-to-metal valve microencapsulated bolt, BERU system	4

Wheel Bolt Tightening Specifications



DANGER!

In order to make sure the wheel bolts fit correctly, be sure to use the correct wheel bolts specified for the model. The wheel bolts for each model have different diameters on the surface of the ball running surface on the wheel rim and they have different lengths.

Model	Model	Tightening Specification
A4 B8	8K	120 Nm
S4 B8	8K	120 Nm
A4 allroad	8K	120 Nm
RS 4 B8	8K	120 Nm

Wheel Alignment Data

Front and all wheel drive.

Specifications valid for all engine versions.

If the vehicle has RHD and the standard chassis (1BA), then check and adjust the camber on the front axle according to the height of the vehicle Anker.

Front axle	Standard suspension (1BA)	China City Suspension (1BB)	Sport suspension (1BE/1BD)	Steel Spring Suspension allroad (1BP)
Camber	- 43' ± 23' Anmerkung	- 43' ± 23'	- 1°5' ± 23'	- 20' ± 23'
Maximum permissible difference between both sides	30'	30'	30'	30'
Toe per wheel (adjustment value)	+ 10' ± 5'	+ 10' ± 5'	+ 10' ± 5'	+ 10' ± 5'
Toe per wheel (control value)	+ 10' ± 7'	+ 10' ± 7'	+ 10' ± 7'	+ 10' ± 7'
Toe-out angle at 20 degrees Anmerkung	1° 49' ± 30'	1° 49' ± 30'	1° 49' ± 30'	1° 49' ± 30'
Outer wheel steering angle at maximum steering angle	33° 12' + 1° 30'- 2°	33° 12' + 1° 30'- 2°	33° 12' + 1° 30'- 2°	33° 12' + 1° 30'- 2°
Inner wheel steering angle at maximum steering angle	39° 36' + 1° 30'- 2°	39° 36' + 1° 30'- 2°	39° 36' + 1° 30'- 2°	39° 36' + 1° 30'- 2°

Front axle	Chassis with electronic damping (1BL)	Heavy duty suspension (1BR)	Sport Suspension S-Line (1BV)
Camber	- 1°5' ± 23'	- 30' ± 23'	- 1°13' ± 23'
Maximum permissible difference between both sides	30'	30'	30'
Toe per wheel (adjustment value)	+ 10' ± 5'	+ 10' ± 5'	+ 10' ± 5'
Toe per wheel (control value)	+ 10' ± 7'	+ 10' ± 7'	+ 10' ± 7'
Toe-out angle at 20 degrees Anmerkung	1° 49' ± 30'	1° 49' ± 30'	1° 49' ± 30'
Outer wheel steering angle at maximum steering angle	33° 12' + 1° 30' - 2°	33° 12' + 1° 30' - 2°	33° 12' + 1° 30' - 2°
Inner wheel steering angle at maximum steering angle	39° 36' + 1° 30' - 2°	39° 36' + 1° 30' - 2°	39° 36' + 1° 30' - 2°

Rear axle	Standard suspension (1BA)	China City Suspension (1BB)	Sport Suspension (1BE)/(1BD)	Steel Spring Suspension allroad (1BP)
Camber	- 1°20' ± 25'	- 1°20' ± 25'	- 1°20' ± 25'	- 1°20' ± 25'
Maximum permissible difference between both sides	30'	30'	30'	30'
Toe per wheel (adjustment value)	+ 10' ± 5'	+ 10' ± 5'	+ 10' ± 5'	+ 10' ± 5'
Toe per wheel (control value)	+ 10' ± 5'	+ 10' ± 5'	+ 10' ± 5'	+ 10' ± 5'
Maximum permissible deviation in direction of travel relative to vehicle longitudinal axis	10'	10'	10'	10'

Rear axle	Chassis with electronic damping (1BL)	Heavy duty suspension (1BR)	Sport Suspension S-Line (1BV)
Camber	- 1°20' ± 25'	- 1°20' ± 25'	- 1°20' ± 25'
Maximum permissible difference between both sides	30'	30'	30'
Toe per wheel (adjustment value)	+ 10' ± 5'	+ 10' ± 5'	+ 10' ± 5'
Toe per wheel (control value)	+ 10' ± 5'	+ 10' ± 5'	+ 10' ± 5'
Maximum permissible deviation in direction of travel relative to vehicle longitudinal axis	10'	10'	10'

- The camber values are defined in the following table based on the vehicle heights at the front axle.

Camber adjustment values on the front axle for RHD vehicles and standard chassis (1BA)						
Vehicle height			Camber			Maximum permissible difference in height between the right and left
Drift	Left and right average absolute value Wheel	Average Delta or specified vehicle height in mm	Test - adjustment dimension	Drift	Maximum permissible difference between both sides	
Too high	401	10	-33'	± 23'	30'	≤ 10 mm
	400	9	-34'			
	399	8	-35'			
	398	7	-36'			
	397	6	-37'			
	396	5	-38'			
	395	4	-39'			
	394	3	-40'			
	393	2	-41'			
	392	1	-42'			
Specified	391	0	-43'			
Too low	390	-1	-44'			
	389	-2	-45'			
	388	-3	-46'			
	387	-4	-47'			
	386	-5	-48'			
	385	-6	-49'			
	384	-7	-50'			
	383	-8	-51'			
	382	-9	-52'			
	381	-10	-53'			

Steering

Steering Gear – Technical Data

Steering gear	Maintenance-free rack-and-pinion steering with servo assist
Turning diameter	Approximately 11.50 m

Fastener Tightening Specifications

Component	Nm
Belt Pulley	22
Electronic Steering Column Lock Control Module to Steering Column Bolt	5
Handle to Steering Column Bolt	3
Power steering pressure line to steering gear bolt	20
Power steering pressure line to rubber bushing nut	6
Power steering pressure line to power steering pump, union nut	40
Power steering pressure line to power steering pump, union nut	38
Power steering pressure line to power steering pump, bolt	9
Power steering return line to steering gear bolt, without dynamic steering	9
Power steering pump mounting bolt	
- 4-cylinder TFSI and 8-cylinder FSI	25
- 6-cylinder	20
Reservoir to tension strap bolt	9
Reservoir tension strap to body bolt	9
Return line to body bolt	9
Right knee bar to steering column bolt ²⁾	
- Coupe	20
- Cabriolet	22
Rubber bushing to power steering gear	6
Servotronic solenoid valve to steering gear bolt ³⁾	3
Steering column mounting bolt	20
Steering intermediate shaft to steering column bolt ¹⁾	80 plus an additional 180° (½ turn)
Steering intermediate shaft to steering gear bolt ¹⁾	30 plus an additional 90° (¼ turn)
Steering intermediate shaft to steering gear bolt ¹⁾	30 plus an additional 90° (¼ turn)

Fastener Tightening Specifications (cont'd)

Component	Nm
Steering wheel to steering column bolt ¹⁾	
- Coupe	50
- Cabriolet	30 plus an additional 90° (¼ turn)
Tie rod to steering gear	90
Tie rod end to tie rod nut	60
Tie Rod End to Wheel Bearing Housing Nut ¹⁾	
- 12-Point Combi Nut	100
Hex Collar Nut	20 plus an additional 90° (¼ turn)
- Hex Combi Nut	110

¹⁾ Always replace after removal.

²⁾ Follow the assembly sequence when installing. Refer to ElsaWeb under *Follow the Assembly Sequence when Installing*

³⁾ Always follow bolt tightening sequence. Refer to ElsaWeb under *Servotronic Solenoid Valve -N119*

Clamp Style	Pliers -V.A.G 1682 A- (Hazet) with adapter -V.A.G 1682 A/1-	Pliers -V.A.G 1682- (Ötiker) with adapter -V.A.G 1682 A/1-
85 mm clamp (front passenger side)	7 Nm	9 Nm
59 mm clamp (driver side)	10 Nm	12 Nm

BRAKE SYSTEM

General, Technical Data

Front Wheel Brakes				
Production-relevant no. (Pr. No.)		1LT	1LA/1LB	1LJ
Brake caliper		FN3- 57 16"	FBC-57 16"	FBC-57 17"
Brake disc ventilated	Dia. mm	314	320	345
Brake disc, thickness	mm	25	30	30
Brake disc, wear limit	mm	23	28	28
Pad thickness with backing plate and dampening sheet	mm	20.3	18.8	18.8
Brake pad wear limit with backing plate and dampening sheet	mm	7	7	7

Rear Wheel Brakes				
Production-relevant no. (Pr. No.)		1KW	1KE	
Brake caliper		CII-43 EPB (16")	CII-43 EPB (17")	
Brake disc	Dia. mm	300	330	
Unvented brake disc thickness	mm	12	-----	
Internally vented brake disc thickness		-----	22	
Brake disc, wear limit	mm	10	20	
Brake caliper, piston	Dia. mm	43	43	
Pad thickness with backing plate and dampening sheet	mm	17.5	17.5	
Brake pad wear limit with backing plate and dampening sheet	mm	7	7	

Antilock Brake System

Fastener Tightening Specifications

Component	Nm
Brake line to hydraulic unit	
- 5 mm diameter M10 brake line	12
- 5 mm diameter M12 brake line	12
- 8 mm diameter M12 brake line	16
Electronic stabilization sensor to floor panel nut	9
Front wheel speed sensor bolt	9
Rear wheel speed sensor bolt	9

Mechanical Components

Fastener Tightening Specifications

Component	Nm
Accelerator pedal module to mounting bracket bolt	8
Electromechanical parking brake control module nut	9
Mounting bracket nut	8
Mounting pin bolt	8
Pedal support bolt	20
Steering column bolt	20
Steering column and mounting bracket bolt	20
Trailer mode control module and bracket nut	3
Universal joint bolt ¹⁾	30 plus an additional 90° (¼ turn)
Front Brakes, with FN3-57 Caliper	
Brake caliper housing guide pin	30
Brake carrier to wheel bearing housing bolt	190
Brake disc to wheel hub bolt	5
Brake hose to brake caliper housing	12
Brake shield to wheel bearing housing bolt	10
Front Brakes, 1LA/1LJ	
Brake carrier to bracket caliper bolt	30
Brake carrier to wheel bearing housing bolt	196
Brake disc to wheel hub bolt	5
Brake line to brake caliper	20
Front Brakes, 1LT	
Brake caliper housing guide pin	30

Component	Nm
Brake carrier to wheel bearing housing bolt	190
Brake disc to wheel bearing housing bolt	5
Brake line to brake caliper	16
Brake shield to wheel bearing housing bolt	18
Front Brakes, 1LM	
Brake shield to wheel bearing housing bolt	10
Brake disc to wheel bearing housing bolt ¹⁾	5
Brake hose to brake caliper	16
Brake pressure line to brake hose	16
Brake carrier to wheel bearing housing bolt ¹⁾	196
Wheel speed sensor to wheel bearing housing	9
Front Brakes, 1LW	
Brake bracket to caliper bolt	25
Brake caliper housing guide pin	30
Brake carrier to wheel bearing housing bolt ¹⁾	190
Brake disc to wheel bearing housing bolt ¹⁾	5
Brake line to brake caliper	16
Brake line connection to brake line	14
Brake shield to wheel bearing housing bolt	9
Rear Brakes, 1KW, 1KE, 2EH	
Brake caliper housing to brake carrier bolt ¹⁾	35
Brake carrier to wheel bearing housing bolt ¹⁾	100 plus an additional 90° (¼ turn)
Brake disc to wheel hub bolt	5
Brake hose to brake caliper housing	12
Brake shield to wheel bearing housing bolt	10
Electromechanical parking brake actuator to brake caliper housing	12

¹⁾ Always replace.

Hydraulic Components

Tightening Specifications

Component	Nm
Brake booster to mounting bracket bolt	25
Brake fluid reservoir cover bolt	5
Brake hose to rear brake caliper	12
Brake line to brake hose bracket	12
Brake line to brake master cylinder	16
Brake line to front brake hose	17
Brake line to hydraulic unit	
- 5 mm diameter M10 brake line	12
- 5 mm diameter M12 brake line	12
- 8 mm diameter M12 brake line	16
Brake line to intermediate piece	12
Brake master cylinder to brake booster nut	49
Pedal support bolt	20
Vacuum hose to vacuum pump bolt (with 2.0L and 3.2L engines)	5
Vacuum pump bolt (with 2.0L and 3.2L engines)	9
Vacuum pump bracket nut (with 3.0L and 4.2L engines)	200
Front Brake Caliper, 1LT	
Bleeder screw to brake caliper housing ²⁾	13
Brake caliper to brake carrier guide pin	30
Front Brake Caliper, FBC Bremse	
Bleeder screw to brake caliper housing ²⁾	15
Brake caliper to brake carrier bolt	30
Brake carrier to wheel bearing housing bolt	196
Front Brake Caliper, 1LW	
Brake carrier to wheel bearing housing bolt	196
Brake line to brake caliper connection	14
Brake line to brake line connection	14
Rear Brake Caliper	
Bleeder screw to brake caliper housing ²⁾	13
Brake caliper housing to brake carrier bolt ¹⁾	35

¹⁾ Always replace.

²⁾ Apply a thin coat of assembly paste -G 052 150 A2- to the threads before installing.

BODY

Air Gap Body Dimensions

Front Gap Dimensions

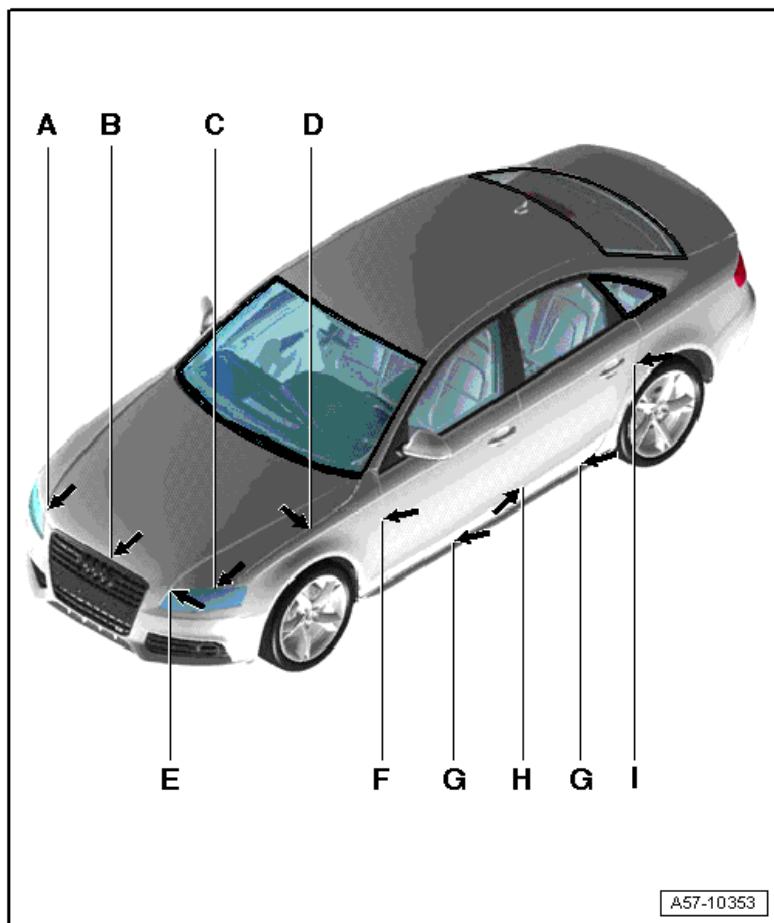

Component	mm
A	5.0 ± 0.5
B	4.5 ± 0.5
C	5.0 ± 0.5
D	3.0 ± 0.5
E	4.5 ± 0.5
F	3.5 ± 0.5
G	5.5 ± 0.5
H	4.5 ± 0.5
I	3.5 ± 0.5

Rear Gap Dimensions

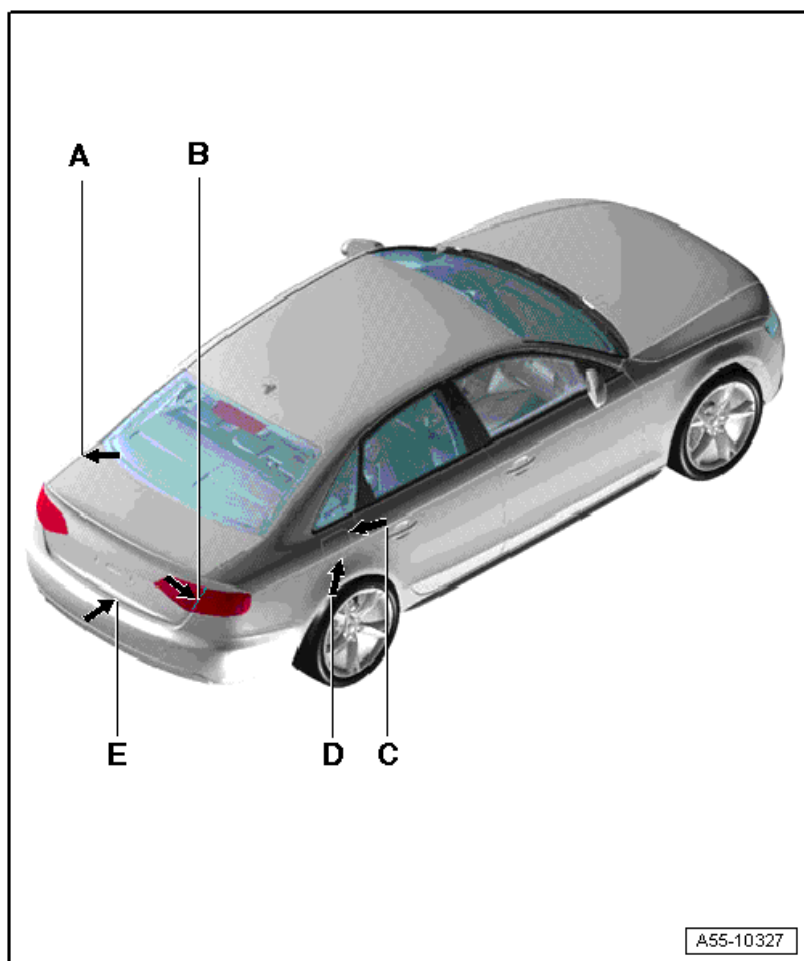

Component	mm
A	4.0 ± 0.5
B	4.5 ± 0.5
C	Front and rear 2.2
D	Top and bottom 2
E	5 ± 0.5

Rear Gap Dimensions – Avant

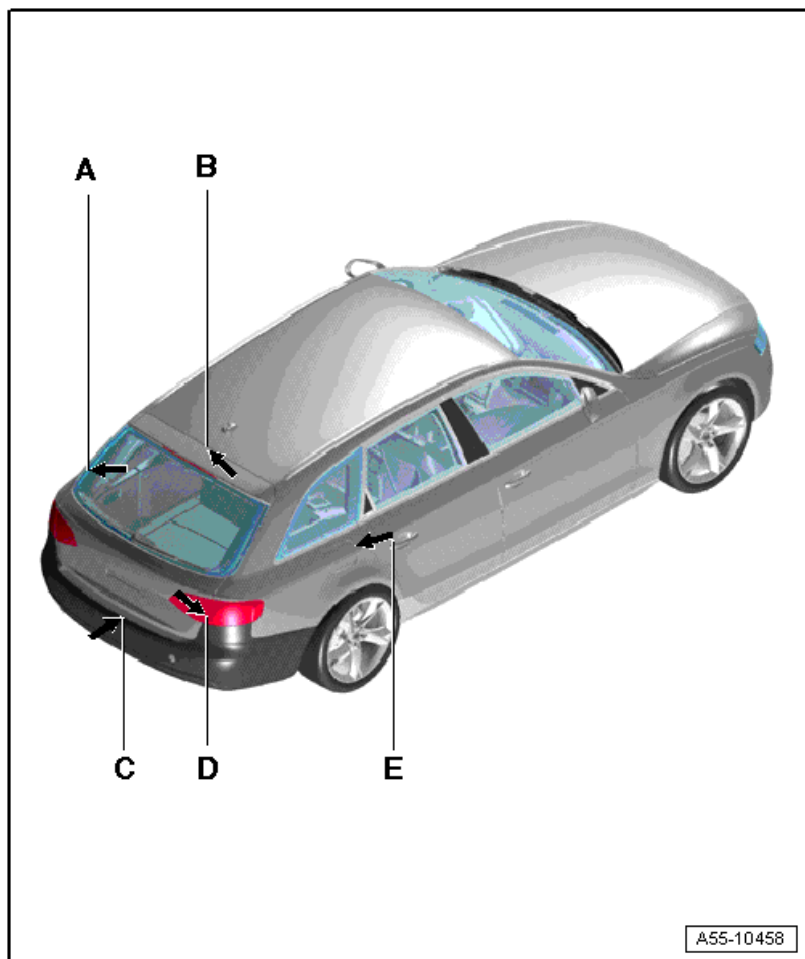

Component	mm
A	3.5 ± 0.5
B	4.5 ± 0.5
C	5.0 ± 0.5
D	3.5 ± 0.5
E	2.2 ± 0.5

Body Exterior

Body Front Tightening Specifications

Component	Nm
Front fender nut	4
Fender to body and rear lower bolts	8
Fender bolt (upper)	10
Fender brace nut	8
Bumper cover mount nut	4
Fender end plate bolt	1.5
Impact member bolt (Qty. 6)	30
Impact member to lock carrier bolt	4
Upper lock carrier bolt	10
Lower lock carrier bolt	1.5
Lock carrier brace bolt	1.5
Lock carrier brace nut	23
Headlamp mount bracket bolt	8
Front bumper cover to bumper contour adjusting nut bolt	8

Hood, Lids Tightening Specifications

Component	Nm
Hood hinge bolt	21
Hood hinge nut	21
Gas strut ball stud	21
Hood catch nuts	8
Hood lock bolt	11
Rear lid lock nut (Sedan)	21
Rear lid lock striker nut (Sedan)	21
Rear lid hinge nut (Sedan)	21
Rear lid hinge bolt (Sedan)	21
Rear lid latch nuts (Avant)	21
Rear lid catch nut (Avant)	21
Rear lid ball stud (Avant)	20
Rear lid hinge bolt (Avant)	21
Fuel filler door bolt	1.7

Front Doors, Central Locking System Tightening Specifications

Component	Nm
Front door hinge to body bolt	32
Front door hinge to door	45
Stud bolt to door hinge	30
Door arrester bolt	25
Door window regulator nut	9
Door window regulator motor bolt	3.5
Outside door handle bolt to backing plate	2.5
Door lock cover bolt	3.5
Door striker bolt	25
Door lock bolt	19

Rear Doors Tightening Specification

Component	Nm
Rear door hinge to body bolt	32
Rear door hinge to door bolt	45
Rear door hinge stud bolt	30
Door arrester bolt	8
Window regulator nut	9
Window regulator motor bolt	3.5
Rear door outside door handle to backing plate bolt	2.5
Door lock bolt	19
Rear door striker bolt	25

Sunroof Tightening Specifications

Component	Nm
Sunroof frame bolt (Sedan)	8
Sunroof frame nut (Sedan)	8
Sunroof motor bolt (Sedan)	4
Sunroof spring bolt (Sedan)	1.5
Sunroof wind deflector bolt (Avant)	1
Sunroof panel 2 bolt (Avant)	3
Sunroof panel 1 bolt (Avant)	7
Sunshade stop bolt (Avant)	1

Bumpers Tightening Specifications

Component	Nm
Bumper cover end plate bolt (rear)	3
Bumper cover end plate bolt (front)	1.5
Front bumper cover mount bolt	4
Radiator grille bolt (allroad)	1.5
Bumper cover bolt (allroad)	4
End plate bolt (allroad)	1.5
Underbody impact guard bolt (allroad)	1.5
Impact member to impact member mount nut	20
Impact member mount to vehicle bolt	55
Bumper Cover Audi RS 4	
Bumper cover end plate bolt	5
Front bumper cover bolt	2

Glass, Window Regulators Tightening Specifications

Component	Nm
Front door window regulator bolt	6
Front door window regulator nut	6
Speaker bolt	1.5
Rear door regulator nut	6

Exterior Equipment Tightening Specifications

Component	Nm
Sill panel cover bolt (allroad)	1.5
Sill panel securing strip nut (allroad)	2
Mirror adjusting unit bolt	1
Mirror adjusting unit mount cover bolt	1
Mirror adjusting unit mount to door bolt	10
Upper radiator grille bolt (short)	1.5
Upper radiator grille bolt (long)	4
Lower rear radiator grille bolt (long)	1.5
Radiator grille license plate bracket bolt (RS 4)	0.9
Parking aid sensor mount bolt (RS 4)	1.5
Reinforcement brace bolt (RS 4)	1.5
Front wheel spoiler bolt	1.5
Front noise insulation bolt	5
Front noise insulation bolt (RS 4)	5
Rear noise insulation bolt (RS 4)	2.1
Rear air guide bolt (RS 4)	3
Front wheel housing liner to bracket bolt (RS 4)	1.7
Front wheel housing liner bolt (RS 4)	2.1
Rear wheel housing liner bolt (RS 4)	1.7
Rear wheel housing liner nut (RS 4)	2

Body Interior

Interior Equipment Tightening Specifications

Component	Nm
Center Console (with a front center armrest)	
Ashtray to console bolt	2.5
Bracket bolt	3
Bracket nut	8
Cupholder to console bolt	1.4
Rear trim to console bolts	2.5
Storage compartment to console bolt	1.4
Trim to console bolts	1.4
Center Console (without a front center armrest)	
Ashtray to console bolt	2.5
Bracket bolt	3
Bracket nut	8
Console to vehicle floor nuts	4
Cupholder to console bolt	1.4
Front Center Armrest	
Padding to bracket bolts	2.2
Support base bolts	3
Support base to vehicle nuts	20
Support base hinge bolts	3
Glove Compartment	
Bolt (front facing)	3
Bolt (threaded clip to compartment)	3
Bolt (underside lower)	3
Bolt (upper)	3
Instrument Panel Cover	
Bolt (front left)	3
Bolt (front right)	3
Bolt (side)	3
Steering Column Trim	
Lower trim screws	2
Release handle bolt	3
Underside of lower trim bolt	2

Passenger Protection, Airbags, Seat Belts Tightening Specifications

Component	Nm
Airbag Control Module	
Airbag control module nuts to vehicle body	9
Airbag Crash Sensors	
Driver side airbag crash sensor	5
Driver side rear side airbag crash sensor	9
Driver front airbag crash sensor	9
Front passenger side airbag crash sensor	5
Passenger side front airbag crash sensor	9
Passenger side rear side airbag crash sensor	9
Battery Interrupt Igniter	
Battery interrupt igniter nuts	15
LATCH Child Seat Anchorage	
Bracket to seat pan screws	8
Center top tether retaining bracket bolts ¹⁾	9
Left top tether retaining bracket bolt ¹⁾	9
Right top tether retaining bracket bolts ¹⁾	9
Driver Airbag/Steering Wheel	
Back of steering wheel bolt	7
Front Side Airbag	
Front side airbag to seat frame bolt	8
Head Curtain Airbag	
Front of head curtain airbag bolts	3.5
Rear of head curtain airbag butts to ground bolt	9
Passenger Airbag	
Nuts for front passenger airbag to vehicle	8
Rear Side Upholstery	
Bolt for side upholstery to vehicle (if equipped with side airbag)	9
Bolt for side upholstery to vehicle (if not equipped with side airbag)	3
Seat Belts	
Driver's front seat buckle to vehicle bolt	33
Passenger's front seat buckle to vehicle bolt	33
Front three-point driver's seat belt to vehicle bottom bolt	45
Front three-point passenger's seat belt to vehicle bottom bolt	45
Front three-point driver's seat belt to vehicle top bolt	45
Front seat belt guide bolts	45
Seat belt height adjuster bolts	5
Rear belt buckle latch bolts	27

Passenger Protection, Airbags, Seat Belts Tightening Specifications (*cont'd*)

Rear center three-point seat belt bolt	45
Rear center three-point seat belt nut	45
Rear outer three-point seat belt lower bolt	45
Rear outer three-point seat belt upper bolt ⁴⁵	45
Seat Position Sensor	
Seat position sensor bolt	0.3
¹⁾ For bolt tightening clarification, these are applicable for allroad model only.	

Interior Trim Tightening Specifications

Component	Nm
Front Door Trim	
Armrest bolts	1.2
Door trim bolts	2.5
Inside door release mechanism bolt	1.2
Pull handle bolt	1.2
Front Sill Panel	
Driver's side front sill panel bolt	2.5
Impact Absorber and Glove Compartment Bracket	
Left retainer for glove compartment bolts	9
Right retainer for glove compartment bolts	9
Left shock absorber bolts	9
Right shock absorber bolts	9
Instrument Panel Central Tube	
Bracket for air intake chamber bolt	9
Bracket for glove compartment	9
Front bracket bolts	20
Front lower support bolt	3.6
Front upper support bolt	20
Interior lower support bolts	20
Interior upper support bolts	3.6
Stud bolt	20
Stud bolt nut	20
Driver's area securing bolts	20
Instrument Panel Components	
Access/start authorization switch trim bolts	3
Light switch trim bolts	1.5
Instrument cluster mounting bracket bolts	3
Support bolts, center (behind MMI screen)	3
Support bolts, left (upper)	3
Support bolts, right (lower)	3
Support bolts, right (upper)	3

Component	Nm
Speaker trim mount nuts	0.5
Pillar Trim	
A-Pillar upper trim bolts	3.5
D-Pillar trim bolts ¹⁾	2
Rear mount bolts ¹⁾	3
Rear Door Trim	
Armrest bolts	1.2
Door trim bolts	2.5
Inside door release mechanism bolt	1.2
Pull handle bolt	1.2
Rear lid trim (allroad)	
Lower trim bolts ¹⁾	2
Rear Lid Trim (Sedan)	
Rear lid trim upper bolt ²⁾	1.8
Rear Luggage Compartment	
Luggage compartment side trim bolts ²⁾	6
Retaining hooks (if equipped) ²⁾	1.5
Rear cross panel trim bolts ¹⁾	1.5
Luggage compartment side trim rear bolt ¹⁾	3
Luggage compartment side trim upper bolt ¹⁾	1.5
Partition screen separator guide cover bolts ¹⁾	9
Partition screen separator bracket bolt ¹⁾	4.5
Partition screen separator mount bolt ¹⁾	9
Rear Shelf (Sedan)	
Rear shelf bolts	2
Rear shelf with spacer (with additional fastener)	2
Rear shelf to spacer bolts	2
Storage Area Floor (allroad)	
Counter-support bolts ¹⁾	1.2
Front bracket main bolt ¹⁾	55
Front bracket secondary bolts ¹⁾	9
Rear bracket bolts ¹⁾	9
Right retaining track bolts ¹⁾	7
Tie down eye bolts ¹⁾	6
Trailer hitch storage bolts (if equipped) ¹⁾	4

Interior Trim Tightening Specifications (*cont'd*)

Component	Nm
Sun Shade (Rear Door)	
Sunshade bolt	1.2
Sun shade mount bolt	1.3
Sun Shade (Rear Windshield)	
Bracket and guide strip bolts	2.3
Rear deck bolts	2
Sun shade to rear shelf nuts	3
¹⁾ For bolt tightening clarification, these are applicable for allroad model only. ²⁾ For bolt tightening clarification, these are applicable for Sedan model only.	

Seat Frames Tightening Specifications

Component	Nm
Front Seat — (Many Components Listed - "If Equipped")	
Backrest to seat pan screws	33
Backrest adjustment motor bolt	7.5
DVD retaining plate screws	6
DVD socket nut	0.4
Lumbar support adjustment switch screws	0.5
Retaining bracket for sill side trim screws	8
Seat adjustment control head	0.4
Seat angle adjuster bolts	6.5
Seat angle adjuster shoulder pin	6
Seat angle adjustment motor bolt	20
Seat angle adjustment motor screws	10
Seat pan to vehicle floor bolts	50
Seat cushion fan air intake grille bolts	1.5
Seat depth adjuster bolts	4
Seat depth adjuster screws	4
Seat height adjuster screws	6.5
Seat height adjuster bolt	10
Seat height adjustment lever screws	8
Seat height adjustment motor to bracket screws	10
Seat pan to lower seat pan frame bolts	22
Shaft for backrest frame nut	6
Sill side trim retaining bracket screws	3.5
Spindle for adjustment bolt (left hand threaded)	18
Storage compartment bolts	8
Rear Seat	
Center armrest bracket with hinges nuts	8
Center armrest bracket with hinges nuts (fixed rear seat backrest)	5

Component	Nm
Center armrest bracket with hinges screws	11
Center armrest bracket with hinges self locking bolts (fixed rear seat backrest)	8
Center armrest with pass-through cover bracket screws	8
Center armrest with pass-through cover hood bolts	11
Center bracket securing bracket bolt	9
Cover for backrest bolts	4
Cover trim for backrest bolt	0.9
Divided backrest center bracket screws	16.5
Fixed rear seat backrest (lower bolts)	33
Fixed rear seat backrest (upper bolts)	30
Inner bearing Assembly Bolt	15
Lock cylinder locking tab bolts	25
Side upholstery bolt (if equipped with side airbag)	9
Side upholstery bolt (if equipped without side airbag)	3

HEATING, VENTILATION & AIR CONDITIONING

General, Technical Data

Refrigerant (PAG) Oil Capacities

Model	Production	Total capacity (cm ³)
1K0 820 803 K Sanden	from 04.04	130 ± 10
1K0 820 803 E Denso	from 04.04	130 ± 10
1K0 820 803 H Zexel	from 04.04	130 ± 10

Refrigerant Oil Distribution

Component	Approximate % of total amount of oil in component
A/C compressor	50
Condenser	10
Suction hose	10
Evaporator	20
Fluid reservoir	10

Refrigerant R134a Vapor Pressure Table

Temperature in °C	Pressure in bar (positive pressure) of R134a
-45	-0.61
-40	-0.49
-35	-0.34
-30	-0.16
-25	0.06
-20	0.32
-15	0.63
-10	1.00
-5	1.43
0	1.92
5	2.49
10	3.13
15	3.90
20	4.70
25	5.63
30	6.70
35	7.83
40	9.10
45	10.54
50	12.11
55	13.83
60	15.72
65	17.79
70	20.05
75	22.52
80	25.21
85	28.14
90	31.34

Air Conditioning

Fastener Tightening Specifications

Component	Fastener Size	Nm
A/C pressure temperature sensor	-	5
Electric Compressor Refrigerant Lines	M6	9
	M8	25
Electric Compressor Mounting Bolt		25
Compressor Oil Drain Plug (Denso)		30
Compressor Bolts 4-cylinder and 8-cylinder		25
Compressor Driveshaft		60
Expansion Valve, Front		10
Expansion Valve, Rear (Hybrid)		10
Hybrid Battery Refrigerant Shut-Off Valve 1 Union		16.5
Pressure Relief Valve (Denso)		10
Refrigerant Line With Inner Heat Exchanger		10

ELECTRICAL SYSTEM

Communication

Tightening Specifications

Component	Nm
Antenna Amplifier 2 and 3	2
Antenna, Radio/Telephone/Navigation System	6
Digital Sound System Control Module	5
External Audio Source Connection	2
Front Information Display Control Head	2
Front Information Display Control Head Control Module	2
Multifunction Buttons	3
Navigation System with CD Drive Control Module	5
Radio	3
Rearview Camera System Control Module Screws	2
Rearview Camera System Control Module Nuts	6
Steering Wheel Tiptronic Switch	1.2

Electrical Equipment

Battery, Starter, Generator, Cruise Control Tightening Specifications

Component	Nm
Battery retaining bracket-to-body bolt	18
Fuse panel A nut	5
Generator bolt	23
Ground wire with battery monitoring control module-to-battery nut	5
Ground wire with battery monitoring control module-to-body nut	20
Spare tire retainer-to-body bolt ²⁾	18
Spare tire-to-retainer nut ²⁾	4
Terminal 30/B+ wire-to-generator nut	16
Terminal B+ wire-to-starter nut	15
Vehicle tool kit cover retainer-to-body bolt ¹⁾	18
Vehicle tool kit cover-to-retainer nut ¹⁾	4
Voltage stabilizer bracket-to-body nut	3

¹⁾ Sedan only

²⁾ Avant only

Instruments Tightening Specifications

Component	Nm
12 V Socket 3-to-trim panel nut	2
Converter with socket 12V - 230V-to-cupholder bolt	1.4
Data bus on board diagnostic interface bolt	3
Horn-to-impact member nut	9
Instrument cluster-to-instrument panel bolt	2.5
Radio frequency controlled clock receiver-to-body bolt	2.5

Windshield Wiper/Washer System Tightening Specifications

Component	Nm
Rear window wiper arm-to-wiper motor nut	12
Rear window wiper motor-to-rear lid nut	8
Windshield wiper arm-to-wiper motor nut	17

Windshield Wiper Motor Bolt Tightening Specification and Sequence

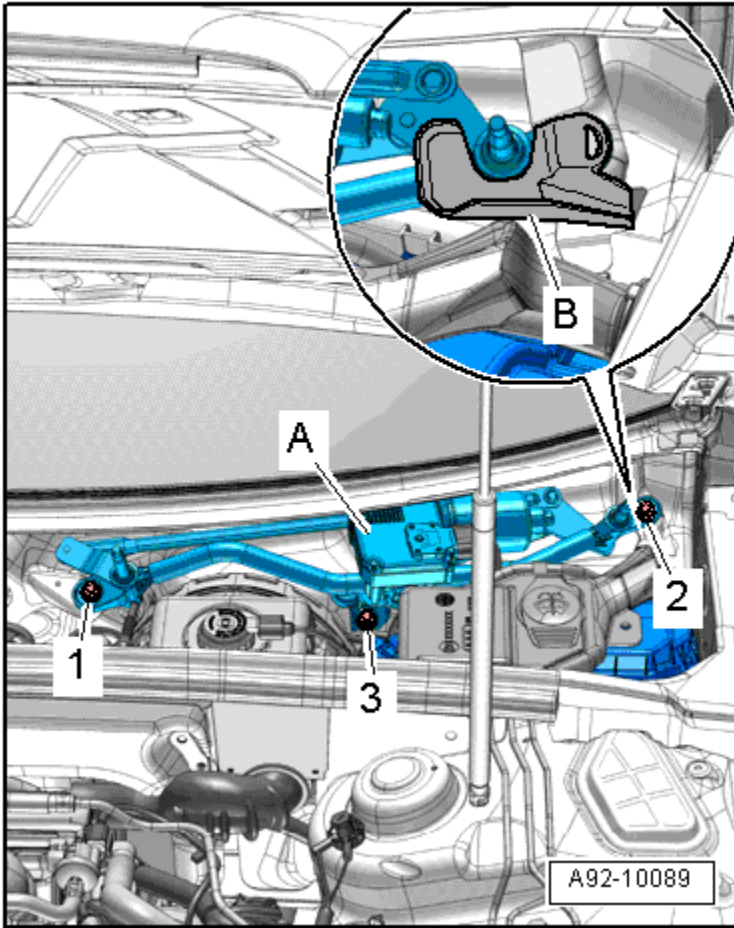

Electrical Equip./
Communication

Stage	Bolts	Tightening Specification/Additional Turn
1	1 through 3 in sequence	Hand-tighten until the bolt is seated
2	1 through 3 in sequence	8

Washer Fluid Reservoir Bolt Tightening Specifications and Sequence

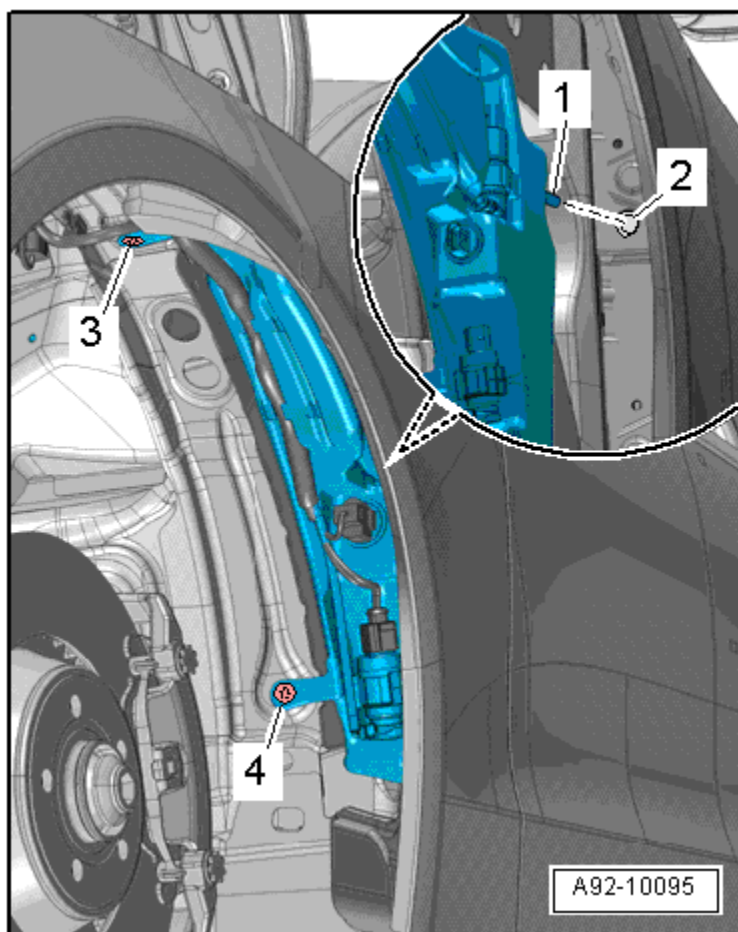

Stage	Bolts	Tightening Specification
1	3	7 Nm
2	3	7 Nm

Exterior Lights, Switches Tightening Specifications

Component	Nm
Access/start authorization switch-to-instrument panel bolt	3
Exterior rearview mirror turn signal bulb-to-exterior rearview mirror housing screw	0.9
Fog lamp-to-body screw	4.5
Headlamp bracket to body screw	4.5
Headlamp mount to body screw	8
Mount to headlamp bracket screw	8
Parking aid control module frame-to-body nut	3
Steering column clamping ring screw	4
Steering column electronic systems control module-to-turn signal, cruise control, windshield wiper and washer intermittent switch bolt	0.5
Halogen headlamp	
Bracket-to-headlamp screw ¹⁾	1.8
Bracket-to-headlamp screw ¹⁾	4.5
Headlamp bracket-to-vent tube adapter screw	4.5
Headlamp range control positioning motor housing cap-to-headlamp	2
Headlamp range control positioning motor-to-headlamp screw	1.4
Headlamp-to-vent tube adapter screw	4.5
Turn signal housing cap-to-headlamp screw	2
Xenon headlamp with cornering light	
Bracket-to-headlamp screw ²⁾	1.8
Bracket-to-headlamp screw ²⁾	4.5
Bracket-to-body screw	4.5
Daytime Running Lamp (DRL) and parking lamp LED module-to-headlamp screw	1.4
Headlamp range control positioning motor-to-headlamp screw	1.4
Headlamp range control positioning motor housing cap-to-headlamp screw	2
HID headlamp control module-to-headlamp screw	1.4
Power output stage-to-headlamp screw	1.4
Tail lamp, sedan	
Bracket-to-rear lid nut	3.5
Bulb socket-to-outer tail lamp screw	1.7
LED tail lamp, sedan	
Body-to-outer tail lamp threaded stud	3.5
Bracket-to-rear lid stud nut	4
Tail lamp, Avant	
Body-to-outer tail lamp threaded stud	3.5

Exterior Lights, Switches Tightening Specifications (*cont'd*)

Component	Nm
Bracket-to-rear lid stud nut	3.5
Bulb socket-to-outer tail lamp nut	3.5
LED Tail Lamp, Avant/Allroad	
Body to outer tail lamp threaded stud	3.5
Bracket to rear lid stud nut	3.5
Inner tail lamp to lid nut	4

- ¹⁾ For clarification on the screws, refer to ElsaWeb under Halogen Headlamp Overview, items 9 and 10.
- ²⁾ For clarification on the screws, refer to ElsaWeb under Xenon Headlamp with Cornering Light Overview, items 10 and 17.

Interior Lights, Switches Tightening Specifications

Component	Nm
Access/start authorization antenna-to-body bolt ¹⁾	2
Access/start authorization antenna in luggage compartment-to-body bolt	2
Alarm horn-to-body bolt ¹⁾	5
	7
Front interior/reading lamp-to-roof bolt	1.6
Headlamp assistant-to-interior rearview mirror bolt	2.4
Lane change assistance control module-to-body screw	3.5
Left access/start authorization antenna-to-body bolt	2
Sunroof adjustment regulator-to-front interior/reading lamp bolt	1

- ¹⁾ For bolt clarification, refer to ElsaWeb under Ultrasonic Interior Monitoring Overview, items 2 and 3.

DTC CHART

Engine Code CAED, CPMB

Fuel and Air Mixture, Additional Emission Regulations

DTC	Error Message	Malfunction Criteria and Threshold Value
P000A	"A" Camshaft Position Slow Response Bank 1	<ul style="list-style-type: none"> • Difference between target position vs. actual position > 8.00° CRK • For time > 1.3 to 2.9 s and • Signal change < 1.9 - 4.2 °CRK/s
P0010	"A" Camshaft Position Actuator Control Circuit/Open Bank 1	Signal voltage, 4.70 to 5.40 V
P0011	"A" Camshaft Position - Timing Over-Advanced or System Performance Bank 1	<ul style="list-style-type: none"> • Difference between target position vs. actual position > 8.00° CRK • For time > 1.3 to 2.9 s and • Adjustment angle < 2.50° CRK
P0016	Crankshaft Position - Camshaft Position Correlation Bank 1 Sensor A	<ul style="list-style-type: none"> • Permissible deviation < 11° Rev or • Permissible deviation > 11° Rev
P0030	HO2S Heater Control Circuit Bank 1 Sensor 1	Heater voltage 4.70 to 5.40 V
P0031	HO2S Heater Control Circuit Low Bank 1 Sensor 1	Heater voltage 0.0 to 2.26 V
P0032	HO2S Heater Control Circuit High Bank 1 Sensor 1	Heater voltage > 5.50 V
P0036	HO2S Heater Control Circuit Bank 1 Sensor 2	Heater voltage, 2.34 - 3.59 V
P0037	HO2S Heater Control Circuit Low Bank 1 Sensor 2	Heater voltage < 2.34 V
P0038	HO2S Heater Control Circuit High Bank 1 Sensor 2	Heater voltage > 3.59 V
P0043	HO2S Heater Control Circuit Low Bank 1 Sensor 3	<ul style="list-style-type: none"> • SULEV Heater voltage < 3 V • ULEV Heater voltage < 3 V

DTC	Error Message	Malfunction Criteria and Threshold Value
P0044	HO2S Heater Control Circuit High Bank 1 Sensor 3	Heater current, > 2.70 to 5.50 A
P0068	MAP/MAF – Throttle Position Correlation	<ul style="list-style-type: none"> • Plausibility with fuel system load calculation < -50% • Plausibility with fuel system load calculation > 50%
P0070	Ambient Air Temperature Sensor Circuit "A"	AAT signal: short to battery / open circuit = failure
P0071	Ambient Air Temperature Sensor Circuit "A" Range/Performance	<ul style="list-style-type: none"> • Diff. ECT vs. IAT at engine start < 24.8 K (depending on engine off time) • Diff. IAT vs. AAT at engine start > 24.8 K (depending on engine off time) • Diff. AAT vs. ECT at engine start > 24.8 K (depending on engine off time)
P0072	Ambient Air Temperature Sensor Circuit "A" Low	AAT signal: short to ground = failure
P0087	Fuel Rail/System Pressure - Too Low Bank 1	<ul style="list-style-type: none"> • Pressure control activity > 5.00 mPa and • Fuel trim activity 0.90 - 120 and • Difference between target pressure vs. actual pressure > -16.38 MPa
P0088	Fuel Rail/System Pressure - Too High	Fuel rail pressure > 13.9 MPa
P0089	Fuel Pressure Regulator 1 Performance	<ul style="list-style-type: none"> • Difference between actual pressure vs. target pressure > 250.00 kPa • Difference between target pressure vs. actual pressure > 200.00 kPa
P008A	Low Pressure Fuel System Pressure - Too Low	Actual pressure < 40.00 kPa
P008B	Low Pressure Fuel System Pressure - Too High	Actual pressure > 950.00 kPa
P0100	Mass or Volume Air Flow Sensor "A" Circuit	MAF sensor signal 0 μ s

DTC	Error Message	Malfunction Criteria and Threshold Value
P0101	Mass or Volume Air Flow A Circuit Range/Performance	<ul style="list-style-type: none"> • Mass air flow vs. lower threshold model < 0 - 417 kg/h • Mass air flow vs. upper threshold > 39 - 873.0 kg/h • Load calculation > 23% • Fuel system (mult.) < -23% • Load calculation < -23.0% and • Fuel system (mult.) > 23%
P0102	Mass or Volume Air Flow Sensor "A" Circuit Low	MAF sensor signal < 66 μ s
P0103	Mass or Volume Air Flow Sensor "A" Circuit High	MAF sensor signal > 4500 μ s
P0106	Manifold Absolute Pressure/Barometric Pressure Sensor Circuit Range/Performance	Boost pressure signal <ul style="list-style-type: none"> • Altitude sensor < -210 hPa • Altitude sensor > 230 hPa
P0111	Intake Air Temperature Sensor 1 Circuit Range/Performance Bank 1	<ul style="list-style-type: none"> • Difference in value between IAT and ECT at engine start (depending on engine off time) > 25 - 40 K • Difference IAT @ manifold vs. AAT at engine start > 24.8 K (depending on engine off time) • Difference AAT vs. ECT at engine start < 24.8 K (depending on engine off time)
P0112	Intake Air Temperature Sensor 1 Circuit Low Bank 1	Signal voltage < 0.16 V
P0113	Intake Air Temperature Sensor 1 Circuit High Bank 1	Signal voltage > 4.48 V

DTC Chart

DTC	Error Message	Malfunction Criteria and Threshold Value
P0116	Engine Coolant Temperature Sensor 1 Circuit Range/Performance	<ul style="list-style-type: none"> • Difference max ECT vs. min ECT < 1.5 K Stuck in Range • No change on signal < 1.5 K • Signal in range (lower threshold) > 89° C 1.5 K • Signal in range (upper threshold) < 110° C Cross Check • Difference ECT vs. IAT at engine start > 24.8 K (depending on engine off time) • Difference IAT @ manifold vs. AAT at engine start > 24.8 K (depending on engine off time) • Difference AAT vs. ECT at engine start > 24.8 K (depending on engine off time)
P0117	Engine Coolant Temperature Sensor 1 Circuit Low	Engine coolant temperature > 140° C
P0118	Engine Coolant Temperature Sensor 1 Circuit High	Engine coolant temperature < -40° C
P0121	Throttle/Pedal Position Sensor/Switch "A" Circuit Range/Performance	<ul style="list-style-type: none"> • TPS 1-TPS 2, > 5.10 to 6.30 % and • Actual TPS 1 -calc. value, > actual TPS 2 calc. value or • TPS 1 calculated value > 9.00%
P0122	Throttle/Pedal Position Sensor/Switch "A" Circuit Low	Signal voltage < 0.20 V
P0123	Throttle/Pedal Position Sensor/Switch "A" Circuit High	Signal voltage > 4.81 V
P0130	O2 Sensor Circuit Bank 1 Sensor 1	O2S ceramic temperature < 640° C
P0131	O2 Sensor Circuit Low Voltage Bank 1 Sensor 1	Virtual mass (VM) < 1.75 V
		Nernst voltage (UN) < 1.50 V
		Adjustment voltage (IA) < 0.30 V
		Adjustment voltage (IP) < 0.30 V

DTC	Error Message	Malfunction Criteria and Threshold Value
P0132	O2 Sensor Circuit High Voltage Bank 1 Sensor 1	Virtual mass (VM) > 3.25 V
		Nernst voltage (UN) > 4.40 V
		Adjustment voltage (IA) > 7.00 V
		Adjustment voltage (IP) > 7.00 V
P0133	O2 Sensor Circuit Slow Response Bank 1 Sensor 1	<p>Symmetric fault:</p> <ul style="list-style-type: none"> • Difference of R2L area ratio vs. L2R area ratio -0.40 - 0.40 • Max value of both counters for area ratio R2L and L2R ≥ 4 times <p>Delay Time:</p> <ul style="list-style-type: none"> • Gradient ratio ≥ 0.00 • Lower value of both area ratios R2L and L2R < 0.30 <p>Transient Time:</p> <ul style="list-style-type: none"> • Gradient ratio ≥ 0.00 • Gradient ratio ≤ 0.45 • Lower value of both area ratios R2L and L2R < 0.30 - or lower value of both gradient ratios R2L and L2R < 0.00 <p>Asymmetric fault:</p> <ul style="list-style-type: none"> • Difference of R2L area ratio vs. L2R area ratio < -0.40; > 0.4 • Values of both counters for area ratio R2L and L2R ≥ 4 times <p>Delay Time:</p> <ul style="list-style-type: none"> • Gradient ratio ≥ 0.00 • Lower value of both area ratios R2L and L2R < 0.30 <p>Transient Time:</p> <ul style="list-style-type: none"> • Gradient ratio ≥ 0.00 • Gradient ratio ≤ 0.45 • Lower value of both area ratios R2L and L2R < 0.30 <p>or</p> <ul style="list-style-type: none"> • Lower value of both gradient ratios R2L and L2R < 0.00

DTC Chart

DTC	Error Message	Malfunction Criteria and Threshold Value
P0135	O2 Heater Circuit Bank 1, Sensor 1	Out of Range: <ul style="list-style-type: none"> • O2S ceramic temperature < 715° C • Heater duty cycle 100% Rationality Check: (Sensor Heating Up): <ul style="list-style-type: none"> • O2S ceramic temperature < 715° C • Time after O2S heater on 40 Sec.
P0136	O2 Circuit Bank 1, Sensor 2	Delta voltage One step at heater switching > 2.00 V and number of heater coupling ≥ 6 times
P0137	O2 Sensor Circuit Low Voltage Bank 1 Sensor 2	<ul style="list-style-type: none"> • Signal voltage < 0.06 V for time > 3 Sec. and <ul style="list-style-type: none"> • Difference of sensor voltage with load pulse and voltage without load pulse (mean value of 3 measurements) < 0.01 V
P0138	O2 Circuit High Voltage Bank 1 Sensor 2	Signal voltage > 1.26 V for > 5 Sec.
P013A	O2 Sensor Slow Response - Rich to Lean Bank 1 Sensor 2	<ul style="list-style-type: none"> • Arithmetic filtered max differential transient time at fuel cut off n.a. or <ul style="list-style-type: none"> • EWMA filtered max differential transient time at fuel cut off ≥ 0.70 s and <ul style="list-style-type: none"> • Number of checks ≥ 3.0
P013B	O2 Sensor Slow Response - Lean to Rich Bank 1 Sensor 2	<ul style="list-style-type: none"> • EWMA filtered transient time at fuel cut-off, ≥ 1.2 s • Number of checks (initial phase) and (step function), > 3.00 -
P013E	O2 Sensor Delayed Response - Rich to Lean Bank 1 Sensor 2	<ul style="list-style-type: none"> • Arithmetic filtered max differential delay time at rich to lean transition > n.a. or <ul style="list-style-type: none"> • EWMA filtered max differential transient time at fuel cut off > 1.0 s and <ul style="list-style-type: none"> • Number of checks ≥ 3.0

DTC	Error Message	Malfunction Criteria and Threshold Value
P013F	O2 Sensor Delayed Response - Lean to Rich Bank 1 Sensor 2	<ul style="list-style-type: none"> EWMA filtered max differential delay time at lean to rich transition ≥ 2.4 to 4.4 s Number of checks ≥ 3.00 - (initial phase and step function)
P0140	O2 Sensor Circuit No Activity Detected Bank 1 Sensor 2	<ul style="list-style-type: none"> Signal voltage, $0.40 - 0.60$ V For time > 3.0 s and Difference of sensor voltage with load pulse and voltage without load pulse (mean value of 3 measurements) ≥ 2.80V Internal resistance > 40000.00 Ω and Exhaust temperature $> 600.0^{\circ}$ C
P0141	O2 Sensor Heater Circuit Bank 1 Sensor 2	Heater resistance $810 - 4560$ Ω
P0145	O2 Sensor Circuit Slow Response Bank 1 Sensor 3	<ul style="list-style-type: none"> EWMA filtered transient time at fuel cut-off, > 0.40 s In voltage range, 401.4 to 201.2 mV Number of checks (initial phase), > 3 Number of checks (step function) > 3
P0169	Incorrect Fuel Composition	Comparison with fuel quantity incorrect
P0171	System Too Lean Bank 1	Lean at idle <ul style="list-style-type: none"> Adaptive value $> 21\%$ Lean at part-load <ul style="list-style-type: none"> Adaptive value 26% (only B8 ULEVVII)
P0172	System Too Rich Bank 1	Too rich at idle <ul style="list-style-type: none"> Adaptive value $< 5.02\%$ ($< 6.0\%$ only B8 ULEV) Too rich at part-load <ul style="list-style-type: none"> Adaptive value $< 21\%$ ($< -26\%$ only B8 ULEVVII)
P0177	Fuel Composition Sensor Circuit Range/Performance	<ul style="list-style-type: none"> Signal fault Possibly in fuel change window after refueling event

DTC	Error Message	Malfunction Criteria and Threshold Value
P0178	Fuel Composition Sensor Circuit Low	Signal Voltage < 1.0 V
P0179	Fuel Composition Sensor Circuit High	Signal Voltage > 2.2 V
P0190	Fuel Pressure Regulator 1 Control Circuit/Open	Signal voltage > 4.90 V
P0191	Fuel Rail Pressure Sensor Circuit Range/Performance Bank 1	Actual pressure \geq 21.30 MPa
P0192	Fuel Rail Pressure Sensor A Circuit Low Input	Signal voltage < 0.2 V
P0201	Cylinder 1 Injector "A" Circuit	<ul style="list-style-type: none"> • Low side signal current < 2.10 A • Internal logic failure
P0202	Cylinder 2 Injector "A" Circuit	<ul style="list-style-type: none"> • Low side signal current < 2.10 A • Internal logic failure
P0203	Cylinder 3 Injector "A" Circuit	<ul style="list-style-type: none"> • Low side signal current < 2.10 A • Internal logic failure
P0204	Cylinder 4 Injector "A" Circuit	<ul style="list-style-type: none"> • Low side signal current < 2.10 A • Internal logic failure
P0221	Throttle/Pedal Position Sensor/Switch B Circuit Range/Performance	<ul style="list-style-type: none"> • TPS 1 - TPS 2 > 6.30% and • Actual TPS 2 calculated value > actual TPS 1 calculated value or <ul style="list-style-type: none"> • TPS 2 calculated value > 9.00%
P0222	Throttle/Pedal Position Sensor/Switch B Circuit Low Input	Signal voltage < 0.20 V
P0223	Throttle/Pedal Position Sensor/Switch B Circuit High Input	Signal voltage > 4.81 V
P0234	Turbocharger/Supercharger "A" Overboost Condition	Difference set value boost pressure vs actual boost pressure value, > 20.00 to 128.00 kPa

DTC	Error Message	Malfunction Criteria and Threshold Value
P0236	Turbocharger/Supercharger Boost Sensor "A" Circuit Range/Performance	<ul style="list-style-type: none"> • Difference boost pressure signal vs altitude sensor signal, > 24.20 kPa • Difference boost pressure signal vs altitude sensor signal, < 14.20 kPa
P0237	Turbocharger/Supercharger Boost Sensor "A" Circuit Low	Signal voltage < 0.20 V
P0238	Turbocharger/Supercharger Boost Sensor "A" Circuit High	Signal voltage > 4.88 V
P0243	Turbocharger/Supercharger Wastegate Solenoid "A"	Signal voltage > 4.40 - 5.60 V
P0245	Turbocharger/Supercharger Wastegate Solenoid "A" Low	Signal voltage < 2.15 - 3.25 V
P0246	Turbocharger/Supercharger Wastegate Solenoid "A" High	Signal current > 2.20 to 4.0 A
P025A	Fuel Pump Module "A" Control Circuit/Open	Signal voltage 4.8 to 5.3 V
P025C	Fuel Pump Module "A" Control Circuit Low	Signal voltage < 2.7 - 3.25 V
P025D	Fuel Pump Module "A" Control Circuit High	Signal current > 0.6 mA
P0261	Cylinder 1 Injector "A" Circuit Low	Signal current < 2.1 A
P0262	Cylinder 1 Injector "A" Circuit High	Signal current > 14.70 A
P0264	Cylinder 2 Injector "A" Circuit Low	Signal current < 2.1 A
P0265	Cylinder 2 Injector "A" Circuit High	Signal current > 14.70 A
P0267	Cylinder 3 Injector "A" Circuit Low	Signal current < 2.1 A
P0268	Cylinder 3 Injector "A" Circuit High	Signal current > 14.70 A
P0270	Cylinder 4 Injector "A" Circuit Low	Low side signal current < 2.1 A
P0271	Cylinder 4 Injector "A" Circuit High	Signal current > 14.70 A

DTC	Error Message	Malfunction Criteria and Threshold Value
P0299	Turbocharger/Supercharger "A" Underboost Condition	Difference set value boost pressure vs actual boost pressure value (filtered) > 15.00 kPa
P2004	Intake Manifold Runner Control Stuck Open Bank 1	<ul style="list-style-type: none"> • Normal closed position, unable to reach • Signal voltage < 2.62 or > 4.65 V or <ul style="list-style-type: none"> • Normal open position, unable to reach • Signal voltage < 0.35 or > 2.38 V
P2008	Intake Manifold Runner Control Circuit/Open (Bank 1)	Signal voltage 4.40 - 5.40 V
P2009	Intake Manifold Runner Control Circuit Shorted Bank 1	Signal voltage 0.00 to 3.26 V
P2010	Intake Manifold Runner Control Circuit/Shorted to B+ Bank 1	Signal current > 2.20 A
P2014	Intake Manifold Runner Position Sensor/Switch Circuit Bank 1	Signal voltage > 4.75 V
P2015	Intake Manifold Runner Position Sensor/Switch Circuit Range/Performance Bank 1	<ul style="list-style-type: none"> • Difference between target position vs. actual position > 25% and <ul style="list-style-type: none"> • Actual position <0.0 to > 100.0% <ul style="list-style-type: none"> • Difference between target position vs. actual position > 25% and <ul style="list-style-type: none"> • Actual position 0.0 to 100.0% <ul style="list-style-type: none"> • Difference between target position vs. actual position > 25% and <ul style="list-style-type: none"> • Actual position 0.0 to 100.0%
P2016	Intake Manifold Runner Position Sensor/Switch Circuit Low Bank 1	Signal voltage < 0.25 V
P2024	EVAP Fuel Vapor Temperature Sensor Circuit	Signal voltage 4.70 to 5.40 V

DTC	Error Message	Malfunction Criteria and Threshold Value
P2025	EVAP Fuel Vapor Temperature Sensor Performance	<p>Functional Check:</p> <ul style="list-style-type: none"> • Reset counter > 3.0 <p>Out of Range Low:</p> <ul style="list-style-type: none"> • Smart module temperature < -39° C <p>Cross Check:</p> <ul style="list-style-type: none"> • Difference between smart temperature and ECT \geq 25.5 K and • Difference between smart temperature and IAT@ manifold \geq 25.5 <p>Functional Check:</p> <ul style="list-style-type: none"> • Time difference between ECU and smart module > 3.0 s <p>Communication with Smart Temperature Sensor</p> <ul style="list-style-type: none"> • Response time > 1000 ms • Number of checks 3.0 • Security bit incorrect and • Number of checks 3.0 <p>Signal Dynamic Check:</p> <ul style="list-style-type: none"> • Gradient smart temperature > 20 K/10 mi <p>Out of Range High</p> <p>Case 1:</p> <ul style="list-style-type: none"> • Smart module temperature > 119° C <p>Case 2:</p> <ul style="list-style-type: none"> • Smart module temperature > 119° C
P2026	EVAP Fuel Vapor Temperature Sensor Circuit Low Voltage	Signal voltage, < 0.00 - 3.25 V
P2027	EVAP Fuel Vapor Temperature Sensor Circuit High Voltage	Signal current > 2.20 A
P2067	Fuel Level Sensor "B" Circuit Low	<ul style="list-style-type: none"> • Instrument cluster module signal: short to ground, failure or • Instrument cluster module signal: signal range check, failure
P2068	Fuel Level Sensor "B" Circuit High	Instrument cluster module signal: short to battery / open circuit, failure

DTC Chart

DTC	Error Message	Malfunction Criteria and Threshold Value
P2088	"A" Camshaft Position Actuator Control Circuit Low Bank 1d	Signal voltage, < 0.00 to 3.25 V
P2089	"A" Camshaft Position Actuator Control Circuit High Bank 1	Signal current, >2.20 A
P2096	Post Catalyst Fuel Trim System Too Lean Bank 1	I-portion of 2nd lambda control loop < -0.045
P2097	Post Catalyst Fuel Trim System Too Rich Bank 1	I-portion of 2nd lambda control loop < -0.045
P303F	Cold Start Injector Circuit	Signal voltage < 3.0 V
P3081	Engine Coolant Temperature measured engine coolant temp. below reference model	Difference reference model temperature vs. ECT > 9.8 K

Ignition System

DTC	Error Message	Malfunction Criteria and Threshold Value
P0300	Random/Multiple Cylinder Misfire Detected	<ul style="list-style-type: none"> • Emission threshold misfire rate (MR) > 2.1% • Catalyst damage misfire rate (MR) > 2.9 - 20.0%
P0301	Cylinder 1 Misfire Detected	<ul style="list-style-type: none"> • Emission threshold misfire rate (MR) > 2.1% • Catalyst damage misfire rate (MR) > 2.9 - 20.0
P0302	Cylinder 2 Misfire Detected	<ul style="list-style-type: none"> • Emission threshold misfire rate (MR) > 2.1% • Catalyst damage misfire rate (MR) > 2.9 - 20.0
P0303	Cylinder 3 Misfire Detected	<ul style="list-style-type: none"> • Emission threshold misfire rate (MR) > 2.1% • Catalyst damage misfire rate (MR) > 2.9 - 20.0
P0304	Cylinder 4 Misfire Detected	<ul style="list-style-type: none"> • Emission threshold misfire rate (MR) > 2.1% • Catalyst damage misfire rate (MR) > 2.9 - 20.0

DTC	Error Message	Malfunction Criteria and Threshold Value
P0321	Ignition/Distributor Engine Speed Input Circuit Range/Performance	<ul style="list-style-type: none"> Counted teeth vs. reference = incorrec or Monitoring reference gap = failure
P0322	Ignition/Distributor Engine Speed Input Circuit No Signal	<ul style="list-style-type: none"> Camshaft signal > 3 Engine speed = no signal
P0324	Knock Control System Error	<ul style="list-style-type: none"> Signal fault counter (combustion) > 24 or Signal fault counter (measuring window) > 2.00
P0327	Knock/Combustion Vibration Sensor 1 Circuit Low Bank 1 or Single Sensor	<ul style="list-style-type: none"> Lower threshold < 70 V or Lower threshold < 0.58 - 1.60 V
P0328	Knock/Combustion Vibration Sensor 1 Circuit High Bank 1 or Single Sensor	<ul style="list-style-type: none"> Upper threshold > 1.00 V or Upper threshold > 18.00 - 150.00 V
P0340	Camshaft Position Sensor "A" Circuit Bank 1 or Single Sensor	<ul style="list-style-type: none"> Cam adaption values out of range > 20° KW < -20° KW Difference of adapted and actual values > 9° KW
P0341	Camshaft Position Sensor "A" Circuit Range/Performance Bank 1 or Single Sensor	<ul style="list-style-type: none"> Signal voltage permanently low and Defect counter 12.00
P0342	Camshaft Position Sensor "A" Circuit Low Bank 1 or Single Sensor	<ul style="list-style-type: none"> Signal voltage permanently low and Crankshaft signals 8.0
P0343	Camshaft Position Sensor "A" Circuit High Bank 1 or Single Sensor	<ul style="list-style-type: none"> Signal voltage permanently high Crankshaft signals 8.0
P0351	Ignition Coil "A" Primary Control Circuit/Open	<ul style="list-style-type: none"> Signal current, 0.25 to 2.0 mA or Internal check failed
P0352	Ignition Coil "B" Primary Control Circuit/Open	<ul style="list-style-type: none"> Signal current, 0.25 to 2.0 mA or Internal check failed

DTC	Error Message	Malfunction Criteria and Threshold Value
P0353	Ignition Coil "C" Primary Control Circuit/Open	<ul style="list-style-type: none"> • Signal current, 0.25 to 2.0 mA or • Internal check failed
P0354	Ignition Coil "D" Primary Control Circuit/Open	<ul style="list-style-type: none"> • Signal current, 0.25 to 2.0 mA or • Internal check failed

Additional Exhaust Regulation

DTC	Error Message	Malfunction Criteria and Threshold Value
P0410	AIR System	Deviation SAI pressure > 20.0 hPa
P0413	AIR System Switching Valve "A" Circuit Open	Signal voltage 9.25 - 11.25 V
P0414	AIR System Switching Valve "A" Circuit Shorted	Signal voltage < 6.00 V
P0415	AIR System Switching Valve "B" Circuit	Signal current 2.20 to 4.20 A
P0418	AIR System Control "A" Circuit	Signal voltage 4.50 - 5.50 V
P0420	Catalyst System Efficiency Below Threshold Bank 1	<ul style="list-style-type: none"> • Measured OSC / OSC of borderline catalyst value for front catalyst , < 1.00 or • Value for front catalyst, <1.30 and • Value for main catalyst, <1.20
P0441	Evaporative Emission System Incorrect Purge Flow	<ul style="list-style-type: none"> • Deviation lambda control < 7.00% and • Deviation idle control < 30.00%
P0442	EVAP System Leak Detected (small leak)	Time for pressure drop < 1.55 to 1.75 s
P0444	EVAP System Purge Control Valve "A" Circuit Open	Signal voltage > 4.40 - 5.40 V
P0450	EVAP System Pressure Sensor/Switch Circuit	Signal voltage > 0.39 to 0.55 V
P0451	EVAP System Pressure Sensor/Switch Circuit Range/Performance	Natural vacuum leak detection (NVLD) switch position closed

DTC	Error Message	Malfunction Criteria and Threshold Value
P0452	EVAP System Pressure Sensor/Switch Circuit Low	Signal voltage < 0.24 V
P0453	EVAP System Pressure Sensor/Switch Circuit High	Signal voltage > 3.0 V
P0455	EVAP System Leak Detected (large leak)	Time for pressure drop < 0.95 Sec.
P0456	EVAP System Leak Detected (very small leak)	< 5.0 - 6.5 Sec.
P0458	EVAP System Purge Control Valve "A" Circuit Low	Signal voltage, 0.0 to 3.26 V
P0459	Evaporative Emission System Purge Control Valve Circuit High	Signal current, > 2.20 A
P0461	Fuel Level Sensor "A" Circuit Range/Performance	Difference between fuel consumption and fuel level changes < -12.00 to 12.00
P0462	Fuel Level Sensor "A" Circuit Low	<ul style="list-style-type: none"> • Instrument cluster module signal: short to ground, failure or • Instrument cluster module signal: signal range check, failure
P0463	Fuel Level Sensor "A" Circuit High	Instrument cluster module signal: short to battery / open circuit, failure
P0491	AIR System Insufficient Flow Bank 1	SAI pressure measured with SAI pressure sensor vs modeled < 0.6 (0.62)%

Speed and Idle Control

DTC	Error Message	Malfunction Criteria and Threshold Value
P0501	Vehicle Speed Sensor "A" Circuit Range/Performance	Vehicle speed < 2 MPH
P0503	Vehicle Speed Sensor "A" Circuit Intermittent/Erratic/High	Vehicle speed > 200 km/h

DTC	Error Message	Malfunction Criteria and Threshold Value
P0506	Idle Control System RPM - Lower Than Expected	Out of Range Low • Engine speed deviation > 80.0 RPM and • Engine speed deviation < -80.0 RPM • RPM controller torque value \geq calculated max. value • Integrated deviation of engine speed low and integrated deviation of engine speed high > 2000.0 RPM
P0507	Idle Control System RPM - Higher Than Expected	• Engine speed deviation < -80.0 RPM and • RPM controller torque value \leq calculated min. value or • Integrated number of fuel cut off transitions = n.a.
P050A	Idle Air Control System RPM Lower Or Higher Than Expected	• Integrated deviation of engine speed low and integrated deviation of engine speed high > 2000 RPM • Engine speed deviation > 80.0 RPM and • RPM controller torque value \geq calculated max. value • Engine speed deviation < -80.0 RPM and • RPM controller torque value \leq calculated min. value or • Integrated number of fuel cut off transitions = n.a.
P050B	Cold Start Ignition Timing Performance	Difference between commanded spark timing vs. actual value > 20.00 - 35.00%
P052A	Cold Start "A" Camshaft Position Timing Over-Advanced Bank 1	Difference between target position and actual position > 12.0°CRK

DTC	Error Message	Malfunction Criteria and Threshold Value
P053F	Cold Start Fuel Pressure Performance	<ul style="list-style-type: none"> • Difference between target pressure vs. actual pressure, > 2.00 MPa and • Difference between target pressure vs. actual pressure, < -2.00 MPa

Control Module and Output Signals

DTC	Error Message	Malfunction Criteria and Threshold Value
P0601	Internal Control Module Memory Check Sum Error	Internal check sum, incorrect
P0604	Internal Control Module Random Access Memory (RAM) Error	Write ability check, failed
P0605	Internal Control Module Read Only Memory (ROM) Error	Check sum incorrect
P0606	Control Module Processor	Internal control module processor failure
P0627	Fuel Pump "A" Control Circuit /Open	<ul style="list-style-type: none"> • Internal error fuel pump control unit • Feedback from fuel pump control unit Pump blocked short circuit to battery voltage, ground or open circuit
P062B	Internal Control Module Fuel Injector Control Performance	SPI communications check Identifier failure
P0634	Control Module Internal Temperature "A" Too High	Power stage temperature > 150° C

DTC	Error Message	Malfunction Criteria and Threshold Value
P0638	Throttle Actuator Control Range/Performance Bank 1	<ul style="list-style-type: none"> • Time to close to reference point > 0.6 Sec. and • Reference point 1.5% • Time to close below reference point > 0.30 s and • Reference point 1.0% • Time to close to reference point > 0.6 s and reference point 2.88% • PS 1 signal voltage < 0.40 also > 0.80 V or TPS 2 signal voltage < 4.20 also > 4.60 V
P0641	Sensor Reference Voltage "A" Circuit/Open	Signal voltage deviation > ± 0.3 V
P0642	Sensor Reference Voltage "A" Circuit Low	Signal voltage < 4.6 - 5.0 V
P0643	Sensor Reference Voltage "A" Circuit High	5V supply voltage > 4.99 - 5.41 V
P0651	Sensor Reference Voltage "B" Circuit/Open	Signal voltage deviation > ± 0.3 V
P0652	Sensor Reference Voltage "B" Circuit Low	Signal voltage < 4.6 - 5.0 V
P0653	Sensor Reference Voltage "B" Circuit High	5V supply voltage > 4.99 - 5.41 V
P0657	Actuator Supply Voltage "A" Circuit/Open	Signal voltage > 4.40 - 5.60 V
P0658	Actuator Supply Voltage "A" Circuit Low	Signal voltage < 2.15 - 3.25 V
P0659	Actuator Supply Voltage "A" Circuit High	Signal current > 1.10 A
P0685	ECM/PCM Power Relay Control Circuit/Open	<ul style="list-style-type: none"> • Signal voltage 2.6 - 3.7 V • Sense circuit voltage > 6 V
P0686	ECM/PCM Power Relay Control Circuit Low	<ul style="list-style-type: none"> • Signal voltage 2.6 - 3.7 V • Sense circuit voltage > 6 V
P0687	ECM/PCM Power Relay Control Circuit High	<ul style="list-style-type: none"> • Signal current > 1.4 - 0.7 A • Sense circuit voltage < 6 V
P0688	ECM/PCM Power Relay Sense Circuit	<ul style="list-style-type: none"> • Sense voltage < 3.0 V • Difference sense circuit voltage with camshaft actuator commanded off and on > 2.5 V • Battery voltage > 3 V

DTC	Error Message	Malfunction Criteria and Threshold Value
P0697	Sensor Reference Voltage "C" Circuit/Open	Signal voltage deviation > ± 0.3 V
P0698	Sensor Reference Voltage "C" Circuit Low	Signal voltage < 4.6 - 5.0 V
P0699	Sensor Reference Voltage "C" Circuit High	5V supply voltage > 4.99 - 5.41 V
P062B	Injection Valves Communication	Internal logic failure
U0001	High Speed CAN Communication Bus	CAN message, no feedback
U0002	High Speed CAN Communication Bus Performance	Global time out, receiving no message
U0100	Lost Communication with ECM/PCM A	<ul style="list-style-type: none"> • Failure of all CAN engine messages, time out > 490 ms • Failure of all CAN engine messages, but not all CAN messages, time out > 1010 ms
U0101	Lost Communication with TCM	Received CAN message, no message
U0121	Lost Communication With Anti-Lock Brake System (ABS) Control Module	Received CAN message, no message
U0140	Lost Communication With Body Control Module	Time out, no message
U0146	Lost Communication With Gateway "A"	Received CAN message, no message
U0155	Lost Communication With Instrument Panel Cluster (IPC) Control Module	Received CAN message, no message
U0302	Software Incompatibility with Transmission Control Module	Received AT vehicle data TCM signal
U0323	Software Incompatibility With Instrument Panel Control Module	AAT value (module not encoded for ambient temp sensor) FDh
U0402	Invalid Data Received From TCM	Received CAN message implausible message

DTC	Error Message	Malfunction Criteria and Threshold Value
U0404	Invalid Data Received From Gear Shift Control Module	<ul style="list-style-type: none"> • If the value of message counter is permanent, constant, or change exceeds a threshold, increment an event counter • Maximum change of message counter > 5
U0415	Invalid Data Received From Anti-Lock Brake System (ABS) Control Module	<p>Out of Range High:</p> <ul style="list-style-type: none"> • Vehicle speed > 202 MPH <p>Can Communication with BSCM:</p> <ul style="list-style-type: none"> • Received data, implausible message <p>Can Communication with Vehicle Speed Sensor:</p> <ul style="list-style-type: none"> • Speed sensor signal: initialization error, 407.296 MPH • Speed sensor signal: low voltage error 407.290 MPH • Speed sensor signal: sensor error 407.303 MPH
U0415	CAN: Vehicle Speed Sensor	<ul style="list-style-type: none"> • Speed sensor signal: initialization error, 655.34km/h • Speed sensor signal: low voltage error 655.33km/h • Speed sensor signal: sensor error 655.35km/h • Vehicle speed \geq 325 km/h
U0422	Invalid Data Received From Body Control Module	AAT value (initialization), Audi, FEh
U0423	Invalid Data Received From Instrument Panel Cluster Control Module	Received CAN message implausible message
U0447	Invalid Data Received From Gateway "A"	Received data, implausible message
U1103	ECM: Production Mode	Production mode = Active

Fuel and Air Ratios Control Module

DTC	Error Message	Malfunction Criteria and Threshold Value
P1114	O2 Sensor Heater Circuit Bank 1 Sensor 2	Heater resistance, (128-648)*(8-40)1.02-25.9 k Ω (dep. on mod. exhaust temp. and heater power)
P12A1	Fuel Rail Pressure Sensor Inappropriately Low	<ul style="list-style-type: none"> • Pressure control activity > 0.25 MPa and • Fuel trim activity < 0.85 and • Difference between target pressure vs. actual pressure -16.38 - 16.38 MPa
P12A2	Fuel Rail Pressure Sensor Inappropriately High	<ul style="list-style-type: none"> • Pressure control activity > 0.25 MPa and • Fuel trim activity < 1.64 and • Difference between target pressure vs. actual pressure -16.38 - 16.38 MPa
P12A4	Fuel Volume Metering Valve Functional Check Valve Stuck Closed	<ul style="list-style-type: none"> • Pressure control activity, < -10.00 MPa and • Fuel trim activity, 0.85 - 1.15 and • Difference between target pressure vs. actual pressure < 16.38 MPa
P13EA	Cold Start Ignition Timing Performance Off Idle	Difference between commanded spark timing and actual value > 0.60%
P150A	Engine Off Time	<ul style="list-style-type: none"> • Difference between engine off time and ECM after run time < -12.0 Sec. • Difference between engine off time and ECM after run time > 12.0 Sec.
P169A	ECM: Transport Mode	Transport mode = active

DTC	Error Message	Malfunction Criteria and Threshold Value
P2101	Throttle Actuator "A" Control Motor Circuit Range/ Performance	<ul style="list-style-type: none"> • Duty cycle >80% and • ECM power stage, no failure • Deviation throttle valve angles vs. calculated value 4.0 - 50.0%
P2106	Throttle Actuator Control System - short to B+ or ground	Short to Battery Voltage or Short to Ground: <ul style="list-style-type: none"> • Internal check, failed Open Circuit: <ul style="list-style-type: none"> • Internal check, failed Current Monitoring: <ul style="list-style-type: none"> • Internal check, failed Functional Check: <ul style="list-style-type: none"> • Internal check, failed
P2110	Throttle Drive Actuator Forced Limited RPM	Engine load out of range
P2122	Throttle/Pedal Position Sensor/Switch "D" Circuit Low	Signal voltage < 0.65 V
P2123	Throttle/Pedal Position Sensor/Switch "D" Circuit High	Signal voltage > 4.79 V
P2127	Throttle/Pedal Position Sensor/Switch "E" Circuit Low	Signal voltage < 0.28 V
P2128	Throttle/Pedal Position Sensor/Switch "E" Circuit High	Signal voltage > 2.431 V
P2138	Throttle/Pedal Position Sensor/Switch D/E Voltage Correlation	Signal voltage sensor 1 vs 2, > 0.14 - 0.70 V
P2146	Fuel Injector Group "A" Supply Voltage Circuit/Open	Short to ground (high side) <ul style="list-style-type: none"> • Signal current > 14.90 A Short to battery plus (high side) <ul style="list-style-type: none"> • Signal current < 2.60 A
P2149	Fuel Injector Group "B" Supply Voltage Circuit/Open	Short to ground (high side) <ul style="list-style-type: none"> • Signal current > 14.90 A Short to battery voltage (high side) or core connection (high side-low side) <ul style="list-style-type: none"> • Signal current < 2.60 A
P2177	System Too Lean Off Idle Bank 1	Adaptive value > 26%
P2178	System Too Rich Off Idle Bank 1	Adaptive value < 26%

DTC	Error Message	Malfunction Criteria and Threshold Value
P2181	Cooling System Performance	Cooling system temp too low after a sufficient air mass flow interval 55 - 80° C
P2187	Fuel System	Adaptive value > 5.02%
P2188	Fuel System	Adaptive value < 6.0%
P2195	O2 Sensor Signal Biased/ Stuck Lean Bank 1 Sensor 1	Delta lambda of 2nd lambda control loop > 0.070
P2196	O2 Sensor Signal Biased/ Stuck Rich Bank 1 Sensor 1	Delta lambda of 2nd lambda control loop < -0.070
P2231	O2 Sensor Signal Circuit Shorted to Heater Circuit Bank 1 Sensor 1	Delta O2S signal front > 190 uA
P2237	O2 Sensor Positive Current Control Circuit/Open Bank 1, Sensor 1	<ul style="list-style-type: none"> • O2S signal front 1.49 - 1.51 and • Difference between maximum and minimum value of O2S voltage signal front < 32.00 V and • Delta lambda controller > 0.10 or • Lambda control at min or max limit • O2S signal front 1.49 - 1.51 and • Difference between maximum and minimum value of O2S voltage signal front < 32.00 V and • No reaction on commanded stepwise change of lambda-setpoint <> 1
P2243	O2 Sensor Reference Voltage Circuit / Open - Bank 1, Sensor 1	<ul style="list-style-type: none"> • O2S signal front < 0.3 to > 3.25 V and • Internal resistance > 1000 Ω
P2251	O2 Sensor Negative Current Control Circuit/Open Bank 1 Sensor 1	<ul style="list-style-type: none"> • O2S voltage signal front 1.45 to 1.53 V and • Internal resistance > 1000 Ω
P2257	AIR System Control "A" Circuit Low	Signal voltage < 3.00 V
P2258	AIR System Control "A" Circuit High	Signal current 0.60 - 1.20 A

DTC Chart

DTC	Error Message	Malfunction Criteria and Threshold Value
P2270	O2 Sensor Signal Biased/ Stuck Lean Bank 1 Sensor 2	Sensor voltage < 0.76 V
P2271	O2 Sensor Signal Biased/ Stuck Rich Bank 1 Sensor 2	Sensor voltage > 0.15 V
P2279	MAP/MAF - Throttle Position Correlation	<ul style="list-style-type: none"> • Threshold to detect a defective system > 1.45 and • Ratio of the tie system defective during the measurement window to the whole duration of the measurement window > 0.60
P2293	Fuel Pressure Regulator 2 Performance	<ul style="list-style-type: none"> • Difference between target pressure vs. actual pressure: > 2.00 mPa • Difference between target pressure vs. actual pressure, < -2.0 mPa
P2294	Fuel Pressure Regulator 2 Control Circuit open circuit	• Signal voltage 1.40 - 3.20 V
P2295	Fuel Pressure Regulator 2 Control Circuit Low short to ground	Signal voltage < 1.40 - 3.20 V
P2296	Fuel Pressure Regulator 2 Control Circuit High	Signal voltage > 3.20 V

Ignition System

DTC	Error Message	Malfunction Criteria and Threshold Value
P2300	Ignition Coil "A" Primary Control Circuit Low	Signal current > 24.0 mA
P2301	Ignition Coil "A" Primary Control Circuit High	Signal current > 5.1 - 7.0 mA
P2303	Ignition Coil "B" Primary Control Circuit Low	Signal current > 24.0 mA
P2304	Ignition Coil "B" Primary Control Circuit High	Signal current > 5.1 - 7.0 mA
P2306	Ignition Coil "C" Primary Control Circuit Low	Signal current > 24.0 mA
P2307	Ignition Coil "C" Primary Control Circuit High	Signal voltage > 5.1 - 7.0 mA

DTC	Error Message	Malfunction Criteria and Threshold Value
P2309	Ignition Coil "D" Primary Control Circuit Low	Signal current > 24.0 mA
P2310	Ignition Coil "D" Primary Control Circuit High	Signal voltage > 5.1 - 7.0 mA

Additional Emissions Regulations

DTC	Error Message	Malfunction Criteria and Threshold Value
P2414	O2 Sensor Exhaust Sample Error Bank 1 Sensor 1	<ul style="list-style-type: none"> • Threshold 1: • Signal voltage 3.1 - 4.81 V • Threshold 2: • Signal Voltage (Depending on gain factor, that actual is used for sensor characteristic, the threshold is switched) 2.5 - 3.10 V
P2431	Rationality check	Difference between SAI pressure and ambient pressure not -25.0 - 25.0 hPa
P2432	Signal Range Check	Signal voltage < 40 V
P2433	Signal Range Check	Signal voltage > 4.65 V
P2440	System Check After SAI PZEV only	SAI pressure measured with SAI pressure sensor vs. modeled while SAI valve closed < 0.55%
P2539	Low Pressure Fuel System Sensor Circuit	Signal voltage > 4.9 V
P2540	Low Pressure Fuel System Sensor Circuit Range/ Performance	Actual pressure deviation < 800 kPa < 80 kPa
P2541	Low Pressure Fuel System Sensor Circuit Low	Signal voltage < 0.2 V
P2626	O2 Sensor Pumping Current Trim Circuit/Open Bank 1 Sensor 1	O2S signal front > 4.81 V

Transmission

DTC	Error Message	Malfunction Criteria and Threshold Value
P2637	Torque management Feedback Signal "A"	CAN message signal error flag, = 1

DTC	Error Message	Malfunction Criteria and Threshold Value
P2714	Pressure Control Solenoid "D" Performance or Stuck off	PWM hardware detection, 0 or 100%
P2715	Pressure Control Solenoid "D" Stuck On	PWM hardware detection, 0 or 100%
P2716	Pressure Control Solenoid "D" Electrical	<ul style="list-style-type: none"> • Current higher or lower than threshold, < 730 mA • EDS output voltage at short to ground or open circuit ~ 0.5 V smaller than EDS supply voltage • Static leakage current flow
P2723	Pressure Control Solenoid "E" Performance or Stuck off	PWM hardware detection, 0 or 100%
P2725	Pressure Control Solenoid "E" Electrical	<ul style="list-style-type: none"> • Current higher or lower than threshold, < 730 mA • EDS output voltage at short to ground or open circuit ~ 0.5 V smaller than EDS supply voltage • Static leakage current flow
P2732	Pressure Control Solenoid "F" Performance or Stuck off	PWM hardware detection, 0 or 100%
P2733	Pressure Control Solenoid "F" Stuck On	PWM hardware detection, 0 or 100%
P2734	Pressure Control Solenoid "F" Electrical	<ul style="list-style-type: none"> • EDS output voltage at short to ground or open circuit ~ 0.5 V smaller than EDS supply voltage • Static leakage current flow
P2735	Pressure Control Solenoid "F" Intermittent	PWM hardware detection, 0 or 100%

DTC CHART

Engine Code CGXC, CTUB

Fuel and Air Mixture, Additional Emission Regulation

DTC	Error Message	Malfunction Criteria and Threshold Value
P000A	A Camshaft Position Slow Response Bank 1	<ul style="list-style-type: none"> • Adjustment angle difference < 5° CA • Number of checks 10 times
P000C	A Camshaft Position Slow Response Bank 2	<ul style="list-style-type: none"> • Adjustment angle difference < 5° CA • Number of checks 10 times
P0010	A Camshaft Position Actuator Circuit / Open Bank 1	Signal current > 0.8 mA
P0011	A Camshaft Position - Timing Over-Advanced or System Performance Bank 1	<ul style="list-style-type: none"> • Adjustment angle difference > 10° CA • Number of checks 3 times
P0016	Crankshaft Position – Camshaft Position Correlation Bank 1 Sensor A	Adaptive value > 146° CA
P0018	Crankshaft Position – Camshaft Position Correlation Bank 2 Sensor A	Adaptive value < 84° CA
P0020	A Camshaft Position Actuator Circuit / Open Bank 2	Signal current < 0.8 mA
P0021	A Camshaft Position - Timing Over-Advanced or System Performance Bank 2	<ul style="list-style-type: none"> • Adjustment angle difference > 10° CA • Number of checks 3 times
P0030	HO2S Heater Control Circuit Bank 1 Sensor 1	Heater current (hardware values) < 8 to 40 mA
P0031	HO2S Heater Control Circuit Low Bank 1 Sensor 1	Heater voltage (hardware values) < 1.9 to 2.22 V
P0032	HO2S Heater Control Circuit High Bank 1, Sensor 1	Heater current (hardware values) > 8 to 11 A
P0036	HO2S Heater Control Circuit Bank 1 Sensor 2	Heater current (hardware values) < 8 to 40 mA
P0037	HO2S Heater Control Circuit Low Bank 1 Sensor 2	Heater voltage < 1.9 to 2.22 V
P0038	HO2S Heater Control Circuit High Bank 1 Sensor 2	Heater current (hardware values) > 3 to 5 A

DTC	Error Message	Malfunction Criteria and Threshold Value
P0042	HO2S Heater Circuit (Bank 1, Sensor 3) open circuit SULEV	Heater voltage 4.50 - 5.50 V
P0043	HO2S Heater Control Circuit Low (Bank 1, Sensor 2) Short to Ground	<ul style="list-style-type: none"> • SULEV Heater voltage < 3 V • ULEV Heater voltage < 3 V
P0044	HO2S Heater Control Circuit High (Bank 1, Sensor 2) Short to Battery voltage	Heater current > 2.70 - 5.50 A
P0050	HO2S Heater Control Circuit Bank 2, Sensor 1	Heater current (hardware values) < 8 to 40 mA
P0051	HO2S Heater Control Circuit Low Bank 2 Sensor 1	Heater voltage (hardware values) < 1.9 to 2.22 V
P0052	HO2S Heater Control Circuit High Bank 2, Sensor 1	Heater current (hardware values) > 8 to 11A
P0056	HO2S Heater Control Circuit Bank 2, Sensor 2	Heater current (hardware values) < 8 to 40 mA
P0057	HO2S Heater Control Circuit Low Bank 2 Sensor 2	Heater voltage < 1.9 to 2.22 V
P0058	HO2S Heater Control Circuit High Bank 2 Sensor 2	Heater current (hardware values) > 3 to 5 A
P0068	MAP/MAF – Throttle Position Correlation	<ul style="list-style-type: none"> • Deviation throttle controller < 43 or > 43% • Difference actual pressure downstream throttle to set-point value >30 kPa
P0071	Ambient Air Temperature Sensor Range/Performance	<ul style="list-style-type: none"> • Difference ECT vs. CHDT vs. IAT at engine start < 26.5° C (depending on engine off time) map (1) • Difference AAT vs. IAT at engine start > 26.5° C (depending on engine off time) map (1) • Difference AAT vs. ECT at engine start > 26.5° C (depending on engine off time) map (1) • Difference AAT vs. CHDT at engine start > 26.5° C (depending on engine off time) map (1)

DTC	Error Message	Malfunction Criteria and Threshold Value
P0072	Ambient Air Temperature Sensor Circuit Low	Failure
P0073	Ambient Air Temperature Sensor Circuit High	Failure
P007C	Charge Air Cooler Temperature Sensor Circuit Low Bank 1	IAT > 129° C
P007D	Charge Air Cooler Temperature Sensor Circuit High Bank 1	IAT < -40° C
P0087	Fuel Rail/System Pressure - Too Low	<ul style="list-style-type: none"> • Deviation fuel rail pressure control > 0.105 g/Rev and • Deviation HO2S control -15 - 15% • actual pressure 3.5 MPa • Target pressure-actual pressure >2 MP and • Deviation HO2S control -15 - 15%
P0088	Fuel Rail/System Pressure - Too High	Fuel rail pressure > 13.9 MPa
P0089	Fuel Pressure Regulator 1 Performance	<ul style="list-style-type: none"> • Deviation fuel press control (LP) < -28% or > 35% • Target press minus actual press > 0.17 MPa • Target press minus actual press < 0.17 MPa
P008A	Low Pressure Fuel System Pressure - Too Low	Actual pressure < 0.08 MPa
P008B	Low Pressure Fuel System Pressure - Too High	Actual pressure >1.1 MPa
P0090	Fuel Pressure Regulator 1 Control Circuit/Open	Signal voltage < 2.9 - 3.2 [V]
P0091	Fuel Pressure Regulator 1 Control Circuit Low	Signal voltage 1.95 - 2.2 [V]
P0092	Fuel Pressure Regulator 1 Control Circuit High	Short to battery plus signal current > 8 to 11 A

DTC	Error Message	Malfunction Criteria and Threshold Value
P0096	Intake Air Temperature Sensor 2 Circuit Range/Performance Bank 1	<ul style="list-style-type: none"> • Difference AAT vs. ECT vs. CHDT at engine start < 26.5° C (depending on engine off time) map (1) • Difference IAT vs. CHDT at engine start > 26.5° C (depending on engine off time) map (1) • Difference IAT vs. AAT at engine start > 26.5° C (depending on engine off time) map (1) • Difference IAT vs. ECT at engine start > 26.5° C (depending on engine off time) map (1)
P00A2	Charge Air Cooler Temperature Sensor Circuit Low Bank 2	IAT > 129 [° C]
P00A3	Charge Air Cooler Temperature Sensor Circuit High Bank 2	IAT < -40 [° C]
P00A6	Intake Air Temperature Sensor 2 Circuit Range/Performance Bank 2	<ul style="list-style-type: none"> • Difference AAT vs. ECT vs. CHDT at engine start < 26.5° C (depending on engine off time) map (1) • Difference IAT vs. CHDT at engine start > 26.5° C (depending on engine off time) map (1) • Difference IAT vs. AAT at engine start > 26.5° C (depending on engine off time) map (1) • Difference IAT vs. ECT at engine start > 26.5° C (depending on engine off time) map (1)

DTC	Error Message	Malfunction Criteria and Threshold Value
P0111	Intake Air Temperature Sensor 1 Circuit Range/Performance Bank 1	<ul style="list-style-type: none"> • Difference AAT vs. ECT vs. CHDT at engine start < 26.5° C (depending on engine off time) map (1) • Difference IAT vs. CHDT at engine start > 26.5° C (depending on engine off time) map (1) • Difference IAT vs. AAT at engine start > 26.5° C (depending on engine off time) map (1) • Difference IAT vs. ECT at engine start > 26.5° C (depending on engine off time) map (1)
P0112	Intake Air Temperature Sensor 1 Circuit Low Bank 1	Intake air temperature > 129° C
P0113	Intake Air Temperature Sensor 1 Circuit High Bank 1	Intake air temperature < -40° C
P0116	Engine Coolant Temperature (Sensor 1) Circuit Range/Performance	<ul style="list-style-type: none"> • Difference AAT vs. ECT vs. IAT at engine start < 26.5° C (depending on engine off time) map (1) • Difference IAT vs. CHDT at engine start > 26.5° C (depending on engine off time) map (1) • Difference IAT vs. AAT at engine start > 26.5° C (depending on engine off time) map (1) • Difference IAT vs. ECT at engine start > 26.5° C (depending on engine off time) map (1)
P0117	Engine Coolant Temperature Sensor 1 Circuit Low	Engine coolant temperature < -45.8° C
P0118	Engine Coolant Temperature Sensor 1 Circuit High	Engine coolant temperature > 141° C
P0121	Throttle/Pedal Position Sensor/Switch "A" Circuit Range/Performance	<ul style="list-style-type: none"> • TPS 1 - TPS 2 > 5.79° and • Relative mass air integral > 100... at 0.45 s

DTC	Error Message	Malfunction Criteria and Threshold Value
P0122	Throttle/Pedal Position Sensor/Switch "A" Circuit Low	Signal voltage, < 0.117 V
P0123	Throttle/Pedal Position Sensor/Switch "A" Circuit High	Signal voltage > 4.6 [V]
P012B	Turbocharger/Supercharger Inlet Pressure Sensor Circuit Range/Performance Downstream of throttle valve	<ul style="list-style-type: none"> • Pressure difference in cross check between boost pressure sensor 1/2; inlet charger pressure and ambient pressure sensor > 7 kPa • Pressure difference in cross check between boost pressure sensor 1/2 and inlet charger pressure (1) > 12..27 kPa • Depending on engine speed
P012C	Turbocharger/Supercharger Inlet Pressure Sensor Circuit Low Downstream of throttle valve	Signal voltage < 0.2 V
P012D	Turbocharger/Supercharger Inlet Pressure Sensor Circuit High Downstream of throttle valve	Signal voltage > 4.8 V
P0130	HO2 Sensor Circuit Bank 1, Sensor 1	O2S ceramic temp. < 640.0° C
P0131	HO2 Sensor Circuit Low Voltage Bank 1 Sensor 1	Signal voltage < 0.13 V
P0132	HO2 Sensor Circuit High Voltage Bank 1 Sensor 1	Signal voltage > 5.5 V
P0133	HO2 Sensor Circuit Slow Response Bank 1 Sensor 1	Response check- HO2S value vs modeled HO2S value > 0.9004
P0135	HO2 Sensor Heater Circuit Bank 1, Sensor 1	UEGO ceramic temperature < 680° C and/or > 965° C
P0136	HO2 Sensor Circuit Bank 1 Sensor 2	Oscillation check <ul style="list-style-type: none"> • O2S signal rear not oscillating at reference +/- 10 mVV Signal range check <ul style="list-style-type: none"> • Signal voltage > 0.15 V
P0137	HO2 Sensor Circuit Low Voltage Bank 1 Sensor 2	<ul style="list-style-type: none"> • Signal voltage, < 20mV and • Internal resistance < 10 O
P0138	HO2 Sensor Circuit High Voltage Bank 1 Sensor 2	Signal voltage > 1.2 V

DTC	Error Message	Malfunction Criteria and Threshold Value
P0139	HO2 Sensor Circuit Slow Response Bank 1 Sensor 2	O2S signal rear- signal too slow- 1
P013A	HO2 Sensor Slow Response - Rich to Lean Bank 1 Sensor 2	<ul style="list-style-type: none"> • Arithmetic filtered max differential transient time at rich to lean transition ≤ 800 mV/s • Number of checks ≥ 2
P013B	HO2 Sensor Slow Response - Lean to Rich Bank 1, Sensor 2	<ul style="list-style-type: none"> • Arithmetic filtered max differential transient time at lean to rich transition ≤ 800 mV/s • Number of checks ≥ 2
P013C	HO2 Sensor Slow Response - Rich to Lean Bank 2 Sensor 2	<ul style="list-style-type: none"> • Arithmetic filtered max differential transient time at rich to lean transition ≤ 800 mV/s • Number of checks ≥ 2
P013D	Oxygen Sensors Slow Response - Lean to Rich Bank 2, Sensor 2	<ul style="list-style-type: none"> • Arithmetic filtered max differential transient time at lean to rich transition ≤ 800 mV/s • Number of checks ≥ 2
P013E	Oxygen Sensors Delayed Response - Rich to Lean Bank 1, Sensor 2	<ul style="list-style-type: none"> • Arithmetic filtered max differential transient time at rich to lean transition ≤ 800 mV/s • Number of checks ≥ 2
P013F	HO2 Sensor Delayed Response - Lean to Rich Bank 1, Sensor 2	<ul style="list-style-type: none"> • Arithmetic filtered max differential transient time at lean to rich transition ≤ 800 mV/s • Number of checks ≥ 2
P0140	HO2 Sensor Circuit No Activity Detected Bank 1 Sensor 2	<ul style="list-style-type: none"> • Signal voltage, 0.376...0.474 V • O2S rear internal resistance > 60 KO
P0141	HO2 Sensor Heater Circuit Bank 1 Sensor 2	Heater resistance, $> 10K \Omega$
P014A	HO2 Sensor Circuit Delayed Response - Lean to Rich Bank 2, Sensor 2	<ul style="list-style-type: none"> • Arithmetic filtered max differential transient time at rich to lean transition ≤ 800 mV/s • Number of checks ≥ 2

DTC	Error Message	Malfunction Criteria and Threshold Value
P014B	HO2 Sensor Circuit Delayed Response - Lean to Rich Bank 2 Sensor 2	<ul style="list-style-type: none"> • Arithmetic filtered max differential transient time at lean to rich transition ≤ 800 mV/s • Number of checks ≥ 2
P0151	HO2 Sensor Circuit Low Voltage Bank 2 Sensor 1	Signal voltage < 0.13 V
P0152	HO2 Sensor Circuit High Voltage Bank 2 Sensor 1	Signal voltage > 5.5 V
P0153	HO2 Sensor Circuit Slow Response Bank 2 Sensor 1	Response check- HO2S value vs modeled HO2S value > 0.7998
P0155	HO2 Sensor Heater Circuit Bank 2, Sensor 1	UEGO ceramic temperature < 680 or $> 965^\circ$ C
P0156	HO2 Sensor Circuit Bank 2 Sensor 2	Oscillation check <ul style="list-style-type: none"> • O2S signal rear not oscillating at reference ± 10 mV Signal range check <ul style="list-style-type: none"> • Signal voltage > 0.15 V
P0157	HO2 Sensor Circuit Low Voltage Bank 2 Sensor 2	<ul style="list-style-type: none"> • Signal voltage, < 20mV and • Internal resistance < 100
P0158	HO2 Sensor Circuit High Voltage Bank 2 Sensor 2	Signal voltage > 1.2 V
P0159	HO2 Sensor Circuit Slow Response Bank 2 Sensor 2	<ul style="list-style-type: none"> • O2S signal rear- signal too slow- 1[-] • Maximum allowed rich to lean switching time
P0160	HO2 Sensor Circuit No Activity Detected Bank 2 Sensor 2	<ul style="list-style-type: none"> • Signal voltage, $0.376 - 0.474$ V • O2S rear internal resistance > 60 KO
P0161	HO2 Sensor Heater Circuit Bank 1, Sensor 2	Heater resistance, $> 10K$ O
P0169	Incorrect Fuel Composition	Plausability check - failed
P0171	System Too Lean Bank 1	System too lean adaptive value > 0.0075 [g/rev]
P0172	System Too Rich Bank 1	System too rich adaptive value < -0.0075 [g/rev]
P0174	System Too Lean Bank 2	System too lean adaptive value > 0.0075 [g/rev]
P0175	System Too Rich Bank 2	System too rich adaptive value < -0.0075 [g/rev]

DTC	Error Message	Malfunction Criteria and Threshold Value
P017B	Cylinder Head Temperature Sensor Circuit Range/Performance	<ul style="list-style-type: none"> • Measured cylinder head temperature below modeled temperature • Difference ETC vs AAT vs IAT at engine start < 26.5° C (depending on engine off time) map (1) • Difference CHDT vs ECT at engine start > 26.5° C (depending on engine off time) map (1) • Difference CHDT vs IAT at engine start > 26.5° C (depending on engine off time) map (1) • Difference CHDT vs AAT at engine start > 26.5° C (depending on engine off time) map (1)
P017C	Cylinder Head Temperature Sensor Circuit Low	Cylinder head temperature > 215 °C
P017D	Cylinder Head Temperature Sensor Circuit High	Cylinder head temperature < -60° C
P0190	Fuel Rail Pressure Sensor "A" Circuit	Signal voltage > 4.6 V
P0191	Fuel Rail Pressure Sensor "A" Circuit Range/Performance	Actual pressure > 16.85 mPa
P0192	Fuel Rail Pressure Sensor "A" Circuit Low	Signal voltage < 0.2 V
P0201	Injector Circuit/Open - Cylinder 1	<ul style="list-style-type: none"> • Signal current < 10 A and • Signal voltage > 3.5 V
P0202	Injector Circuit/Open - Cylinder 2	<ul style="list-style-type: none"> • Signal current < 10 A and • Signal voltage > 3.5 V
P0203	Injector Circuit/Open - Cylinder 3	<ul style="list-style-type: none"> • Signal current < 10 A and • Signal voltage > 3.5 V
P0204	Injector Circuit/Open - Cylinder 4	<ul style="list-style-type: none"> • Signal current < 10 A and • Signal voltage > 3.5 V

DTC	Error Message	Malfunction Criteria and Threshold Value
P0205	Injector Circuit / Open - Cylinder 5	<ul style="list-style-type: none"> • Signal current < 10 A and • Signal voltage > 3.5 V
P0206	Injector Circuit / Open - Cylinder 6	<ul style="list-style-type: none"> • Signal current < 10 A and • Signal voltage > 3.5 V
P0221	Throttle/Pedal Position Sensor/Switch "B" Circuit Range/Performance	<ul style="list-style-type: none"> • TPS 1 - TPS 2 > 5.79% and • Relative mass air integral > 100... at 0.45 s
P0222	Throttle/Pedal Position Sensor/Switch "B" Circuit Low	Signal voltage, <0.117 V
P0223	Throttle/Pedal Position Sensor/Switch "B" Circuit High	Signal voltage, > 4.6 V
P0234	Turbocharger/Supercharger Overboost Condition Rationality Check High	Difference set value boost pressure vs actual boost pressure value, > 200 - 1275 hPa
P0235	Turbocharger/Supercharger Boost Sensor "A" Circuit	Difference between actual measured charge pressure quotient and target charge pressure quotient (1) > 0.25 - 35 [-] depending on altitude
P0236	Turbocharger/Supercharger Boost Sensor "A" Circuit Range/Performance	<ul style="list-style-type: none"> • Pressure difference in cross check between boost pressure sensor 1/2; inlet charger pressure and ambient pressure sensor > 7 kPa • Pressure difference in cross check between boost pressure sensor 1/2 and inlet charger pressure (1) > 12 - 27 kPa • Pressure difference in cross check between pressure sensor 1 and 2 > 12.5 kPa • Fuel trim activity (bank with deviation is considered to be defective) > 15%
P0237	Turbocharger/Supercharger Boost Sensor "A" Circuit Low	Signal voltage, < 0.2 V
P0238	Turbocharger/Supercharger Boost Sensor "A" Circuit High	Signal voltage > 4.8 V

DTC	Error Message	Malfunction Criteria and Threshold Value
P0240	Turbocharger/Supercharger Boost Sensor "B" Circuit Range/Performance	<ul style="list-style-type: none"> • Pressure difference in cross check between boost pressure sensor 1/2; inlet charger pressure and ambient pressure sensor > 7 kPa • Pressure difference in cross check between boost pressure sensor 1/2 and inlet charger pressure (1) > 12 - 27 kPa • Pressure difference in cross check between pressure sensor 1 and 2 > 12.5 kPa • Fuel trim activity (bank with deviation is considered to be defective) > 15%
P0241	Turbocharger/Supercharger Boost Sensor "B" Circuit Low	Signal voltage, < 0.2 V
P0242	Turbocharger/Supercharger Boost Sensor "B" Circuit High	Signal voltage, > 4.8 V
P025A	Fuel Pump Module Control Circuit/Open	Signal voltage < 2.9 to 3.2 [V]
P025C	Fuel Pump Module Control Circuit Low	Signal voltage < 1.95 to 2.2 V
P025D	Fuel Pump Module Control Circuit High	Signal current > 1 to 2 A
P0261	Cylinder 1 Injector Circuit Low	<ul style="list-style-type: none"> • Signal current < 10 A and • Signal voltage < 3.5 V
P0262	Cylinder 1 Injector Circuit High	Signal current > 16 A
P0264	Cylinder 2 Injector Circuit Low	<ul style="list-style-type: none"> • Signal current < 10 A and • Signal voltage < 3.5 V
P0265	Cylinder 2 Injector Circuit High	Signal current > 16 A
P0267	Cylinder 3 Injector Circuit Low	<ul style="list-style-type: none"> • Signal current < 10 A and • Signal voltage < 3.5 V
P0268	Cylinder 3 Injector Circuit High	Signal current > 16 A
P0270	Cylinder 4 Injector Circuit Low	<ul style="list-style-type: none"> • Signal current < 10 A and • Signal voltage < 3.5 V
P0271	Cylinder 4 Injector Circuit High	Signal current > 16 A

DTC	Error Message	Malfunction Criteria and Threshold Value
P0273	Cylinder 5 Injector Circuit Low	<ul style="list-style-type: none"> • Signal current < 10 A and • Signal voltage < 3.5 V
P0275	Cylinder 5 Injector Circuit High	Signal current > 16 A
P0276	Cylinder 6 Injector Circuit Low	<ul style="list-style-type: none"> • Signal current < 10 A and • Signal voltage < 3.5 V
P0277	Cylinder 6 Injector Circuit High	Signal current > 16 A
P0299	Turbocharger/Supercharger Underboost Rationality Check	Difference set value boost pressure vs actual boost pressure value, > 150 hPa
P2004	Intake Manifold Runner Control Stuck Open Bank 1	Signal voltage, > 2.5 V
P2005	Intake Manifold Runner Control Stuck Open Bank 2	Signal voltage, > 2.5 V
P2006	Intake Manifold Runner Control Stuck Closed Bank 1	Signal voltage, < 2.9 V
P2007	Intake Manifold Runner Control Stuck Closed Bank 2	Signal voltage > 2.9 V
P2008	Intake Manifold Runner Control Circuit/Open	Signal voltage 2.9 to 3.2 V
P2009	Intake Manifold Runner Control Circuit Low	Signal voltage < 1.95 to 2.2 V
P2010	Intake Manifold Runner Control Circuit High	Signal current 1.2 A
P2014	Intake Manifold Runner Position Sensor/Switch Circuit Bank 1	Signal voltage, < 0.2 V
P2017	Intake Manifold Runner Position Sensor/Switch Circuit High Bank 1	Signal voltage, > 4.8 V
P2019	Intake Manifold Runner Position Sensor/Switch Circuit Bank 2	Signal voltage, < 0.2 V
P2022	Intake Manifold Runner Position Sensor/Switch Circuit High Bank 2	Signal voltage, > 4.8 V
P2024	Evaporative Emissions (EVAP) Fuel Vapor Temperature Sensor Circuit	Signal Current < 0.8 mA

DTC	Error Message	Malfunction Criteria and Threshold Value
P2025	Evaporative Emissions (EVAP) Fuel Vapor Temperature Sensor Performance	<ul style="list-style-type: none"> • Response time > 1000 ms and number of checks > 3.00 • Security bit incorrect and number of checks > 3.00 • Resetcounter > 3.00 • Time difference between ECU and EVAP Fuel Tank Temp Sensor > 3.0 s • EVAP Fuel Tank Temp Sensor > 119° C • EVAP Fuel Tank Temp Sensor < -39° C • Difference between EVAP Fuel Tank Temp Sensor and ECT ≥ 20.3 K and <ul style="list-style-type: none"> • Differenc between EVAP Fuel Tank Temp Sensor and IAT ≥ 20.3 K gradient EVAP Fuel Tank Temp Sensor > 20 [K/10min]
P2026	Evaporative Emissions (EVAP) Fuel Vapor Temperature Sensor Circuit Low Voltage	Signal Voltage < 2.0 V
P2027	Evaporative Emissions (EVAP) Fuel Vapor Temperature Sensor Circuit High Voltage	Signal Current > 1.0 A
P2088	A Camshaft Position Actuator Control Circuit Low Bank 1	Signal voltage, < 1.95 to 2.20 V
P2089	A Camshaft Position Actuator Control Circuit High Bank 1	Signal current, > 3 to 5 A
P2092	A Camshaft Position Actuator Control Circuit Low Bank 2	Signal voltage, < 1.95 to 2.20 V
P2093	A Camshaft Position Actuator Control Circuit High Bank 2	Signal current, > 3 to 5 A
P2096	Post Catalyst Fuel Trim System Too Lean Bank 1	Integral part of trim control, post cat > 10%
P2097	Post Catalyst Fuel Trim System Too Rich Bank 1	Integral part of trim control, post cat < 10%
P2098	Post Catalyst Fuel Trim System Too Lean Bank 2	Integral part of trim control, post cat > 10%

DTC Chart

DTC	Error Message	Malfunction Criteria and Threshold Value
P2099	Post Catalyst Fuel Trim System Too Rich Bank 2	Integral part of trim control, post cat < 10%
P3081	Engine Temperature Too Low	Step 1 • Modeled ECT > 30° C and • ECT < 30° C

Ignition System

DTC	Error Message	Malfunction Criteria and Threshold Value
P0300	Random/Multiple Cylinder Misfire Detected	<ul style="list-style-type: none"> • Emission threshold misfire rate (MR) 1st interval > 1.5% • Emission threshold misfire rate (MR) > 1.5% • Catalyst damage, misfire rate (MR) > 1.5 - 15%
P0301	Cylinder 1 Misfire Detected	<ul style="list-style-type: none"> • Emission threshold misfire rate (MR) 1st interval > 1.5% • Emission threshold misfire rate (MR) > 1.5% • Catalyst damage, misfire rate (MR) > 1.5 - 15%
P0302	Cylinder 2 Misfire Detected	<ul style="list-style-type: none"> • Emission threshold misfire rate (MR) 1st interval > 1.5% • Emission threshold misfire rate (MR) > 1.5% • Catalyst damage, misfire rate (MR) > 1.5 - 15%
P0303	Cylinder 3 Misfire Detected	<ul style="list-style-type: none"> • Emission threshold misfire rate (MR) 1st interval > 1.5% • Emission threshold misfire rate (MR) > 1.5% • Catalyst damage, misfire rate (MR) > 1.5 - 15%
P0304	Cylinder 4 Misfire Detected	<ul style="list-style-type: none"> • Emission threshold misfire rate (MR) 1st interval > 1.5% • Emission threshold misfire rate (MR) > 1.5% • Catalyst damage, misfire rate (MR) > 1.5 - 15%

DTC	Error Message	Malfunction Criteria and Threshold Value
P0305	Cylinder 5 Misfire Detected	<ul style="list-style-type: none"> • Emission threshold misfire rate (MR) 1st interval > 1.5% • Emission threshold misfire rate (MR) > 1.5% • Catalyst damage, misfire rate (MR) > 1.5 - 15%
P0306	Cylinder 6 Misfire Detected	<ul style="list-style-type: none"> • Emission threshold misfire rate (MR) 1st interval > 1.5% • Emission threshold misfire rate (MR) > 1.5% • Catalyst damage, misfire rate (MR) > 1.5 - 15%
P0326	Knock Sensor 1 Circuit Range/Performance Bank 1 or Single Sensor	<ul style="list-style-type: none"> • Lower threshold < 0.029 V • Upper threshold > 1.992 V
P0327	Knock Sensor 1 Circuit Low Bank 1 or Single Sensor	Lower threshold, < 0.18 V
P0328	Knock Sensor 1 Circuit High Bank 1 or Single Sensor	Upper threshold > 4.8 V
P0331	Knock Sensor 2 Circuit Range/Performance Bank 2	<ul style="list-style-type: none"> • Lower threshold < 0.029 V • Upper threshold > 1.992 V
P0332	Knock Sensor 2 Circuit Low Bank 2	Lower threshold, < 0.18 V
P0335	Engine Speed Sensor	<ul style="list-style-type: none"> • Open circuit > 1 V • Short to grnd < 1.5 V • Short to Battery voltage > 3.5 V • Signal check no signal
P0336	Crankshaft Position Sensor "A" Circuit Range/Performance	<ul style="list-style-type: none"> • RPM signal comparison with camshaft sensors not synchronous • Counted versus reference teeth > 1 • Actual time value vs modeled time value > 1.375[-]
P0340	Camshaft Position Sensor "A" Circuit Bank 1 or Single Sensor	Signal activity check <ul style="list-style-type: none"> • Signal voltage no altering @ 4 Rev

DTC	Error Message	Malfunction Criteria and Threshold Value
P0341	Camshaft Position Sensor "A" Circuit Range/Performance Bank 1 or Single Sensor	<ul style="list-style-type: none"> • Actual time value vs min. time value < 1 • Adaptive value vs target value > 12.4° CA • Actual time value vs modeled time value > 3.5
P0345	Camshaft Position Sensor "A" Circuit Bank 2	<ul style="list-style-type: none"> • Signal activity check • Signal voltage no altering @ 4 Rev
P0346	Camshaft Position Sensor "A" Circuit Range/Performance Bank 2	<ul style="list-style-type: none"> • Actual time value vs min. time value < 1 • Adaptive value vs target value > 12.4° CA • Actual time value vs modeled time value > 3.5
P0351	Ignition Coil "A" Primary/ Secondary Circuit	<p>Open circuit</p> <ul style="list-style-type: none"> • Signal current, < -0.05 - 0.2mA • Hardware value from final stage > 0.04 - 0.2 mA
P0352	Ignition Coil "B" Primary/ Secondary Circuit	<p>Short to ground</p> <ul style="list-style-type: none"> • Signal current, < -0.05 - 0.2mA • Hardware value from final stage > 0.04 - 0.2 mA
P0353	Ignition Coil "C" Primary/ Secondary Circuit	<p>Short to Battery voltage</p> <ul style="list-style-type: none"> • Signal current, < -0.05 - 0.2mA • Hardware value from final stage > 0.04 - 0.2 mA
P0354	Ignition Coil "D" Primary/ Secondary Circuit	<ul style="list-style-type: none"> • Signal current, < -0.05 - 0.2mA • Hardware value from final stage > 0.04 - 0.2 mA
P0355	Ignition Coil "E" Primary/ Secondary Circuit	<ul style="list-style-type: none"> • Signal current, < -0.05 - 0.2mA • Hardware value from final stage > 0.04 - 0.2 mA
P0356	Ignition Coil "F" Primary/ Secondary Circuit	<ul style="list-style-type: none"> • Signal current, < -0.05 - 0.2mA • Hardware value from final stage > 0.04 - 0.2 mA

Additional Exhaust Regulation

DTC	Error Message	Malfunction Criteria and Threshold Value
P0413	Secondary Air Injection System Switching Valve "A" Circuit Open	<ul style="list-style-type: none"> • Signal Current 8 to 40 mA • Signal Voltage 2.9 to 3.2 V
P0414	Secondary Air Injection System Switching Valve "A" Circuit Shorted	Short to Battery Voltage: <ul style="list-style-type: none"> • Signal Current 3 to 5 A Short to Ground
P0416	Secondary Air Solenoid Valve 2 Circuit Open Circuit	Signal voltage < 8 mA
P0417	Secondary Air Solenoid Valve 2 Circuit Short to Ground or Battery Voltage	Signal voltage < 2.00 V
P0418	Secondary Air Injection System Control "A" Circuit	<ul style="list-style-type: none"> • Signal current < 1 [mA] • Signal Voltage 2.9 to 3.2 [V]
P0420	Catalyst System Efficiency Below Threshold Bank 1	Amplitude ratio O2S > 1.5 [-]
P0430	Catalyst System Efficiency Below Threshold Bank 2	Amplitude ratio O2S > 1.5
P0441	Evaporative Emission System Incorrect Purge Flow	Deviation HO2S control < 4% <ul style="list-style-type: none"> • Purge valve quality < 0,05 [-]
P0442	EVAP System Leak Detected LDP (Small Leak)	Time for pressure drop < 1.06...1.3 s.
P0444	Evaporative Emission System Purge Control Valve Circuit Open	Signal current < 0.8mA
P0445	Evaporative Emission System Purge Control Valve Circuit Shorted	<ul style="list-style-type: none"> • Signal voltage < 2.0 V or • Signal current >5.0 A
P0450	Evaporative Emission System Pressure Sensor/Switch	<ul style="list-style-type: none"> • Signal voltage 2.9 to 3.2 V or • Signal current 0.8 to 4 mA
P0451	Evaporative Emission System Pressure Sensor/Switch Range/Performance	NVLD Pressure Sensor / Switch = Closed
P0452	Fuel Tank Leak Detection System (NVLD) Short to Battery Voltage	Signal Voltage > 3.0 V
P0453	Evaporative Emission System Pressure Sensor/Switch	<ul style="list-style-type: none"> • Signal Current 1 to 2 A or • Signal Voltage 2 V

DTC	Error Message	Malfunction Criteria and Threshold Value
P0455	EVAP System Leak Detected LDP (Large Leak Detected)	Time for pressure drop < 0.65 - 0.7 s.
P0456	EVAP System Leak Detected NVLD (very small leak)	NVLD switch position open
P0458	Evaporative Emission System Purge Control Valve Circuit Low	Signal voltage < 2.15 - 3.25 V
P0459	Evaporative Emission System Purge Control Valve Circuit High	Signal current > 2.20 A
P0491	Secondary Air Injection System Insufficient Flow Bank 1	Diference between reference AIR mass flow and calculated AIR mass flow > 18 to 21 [kg/h]
P0492	Secondary Air Injection System Insufficient Flow Bank 2	Diference between reference AIR mass flow and calculated AIR mass flow > 18 to 21 [kg/h]

Speed and Idle Control

DTC	Error Message	Malfunction Criteria and Threshold Value
P0501	Vehicle Speed Sensor "A" Range/Performance	Communication check • Sensor signal failure
P0502	Vehicle Speed Sensor "A" Circuit Low	Communication check • Sensor signal failure
P0503	Vehicle Speed Sensor Range/Performance	Vehicle speed > 200 km/h
P0506	Idle Air Control System - RPM Lower Than Expected	Engine speed deviation < -80 RPM
P0507	Idle Air Control System - RPM Higher Than Expected	Engine speed deviation > -80 RPM
P050A	Cold Start Idle Air Control System Performance	Out of range low • Engine speed deviation 1 < 80 - 250 RPM • Out of range high • Engine speed deviation 2 > 80 - 250 RPM
P050B	Cold Start Ignition Timing Performance	Idle Difference between commanded spark timing vs. actual value > 20%

DTC	Error Message	Malfunction Criteria and Threshold Value
P052A	Cold Start "A" Camshaft Position Timing Over-Advanced Bank 1	<ul style="list-style-type: none"> • Adjustment angle difference > 10° CA • Number of checks 2
P052C	Cold Start "A" Camshaft Position Timing Over-Advanced Bank 2	<ul style="list-style-type: none"> • Adjustment angle difference > 10° CA • Number of checks 2
P053F	Cold Start Fuel Pressure Performance	Target pressure-actual pressure > 1.5 MPa

Control Module and Output Signals

DTC	Error Message	Malfunction Criteria and Threshold Value
P0601	Internal Control Module Memory Check Sum Error	Internal check sum, incorrect
P0603	Internal Hardware Check	SPI communication lost
P0604	Internal Control Module Random Access Memory (RAM) Error	Write ability check, failed
P0605	Internal Control Module Read Only Memory (ROM) Error	Check sum incorrect
P0606	Control Module Processor ECM fault	EEPROM check..failed
P0627	Fuel Pump "A" Control Circuit /Open	<ul style="list-style-type: none"> • Internal error fuel pump control unit • Feedback from fuel pump control unit pump blocked short circuit to battery +, ground or open circuit

DTC	Error Message	Malfunction Criteria and Threshold Value
P0638	Throttle Actuator Control Range/Performance Bank 1	Functional check: close movement <ul style="list-style-type: none"> • Open to 15° > 1.275 s • Then close to ref. point > 1.28 s • Gradient < 7° per second Functional check open movement <ul style="list-style-type: none"> • Close to 1.99° > 1.275 s • Then open to ref. point > 1.28 s • Gradient < 7° per second Signal range check @ mechanical stop low <ul style="list-style-type: none"> • TPS 1 signal voltage out-off range 0.208 - 0.852 V or • TPS 2 signal voltage out off range 4.158 - 4.802 V
P0641	Sensor Reference Voltage A Circuit/Open	Signal voltage deviation > ± 0.3 V
P0642	Sensor Reference Voltage A Circuit Low	Signal voltage < 4.62 V
P0643	Sensor Reference Voltage A Circuit High	5V supply voltage > 5.44 V
P0651	Sensor Reference Voltage B Circuit/Open	Signal voltage deviation > ± 0.3 V
P0652	Sensor Reference Voltage B Circuit Low	Signal voltage < 4.62 V
P0653	Sensor Reference Voltage B Circuit High	5V supply voltage > 4.99 - 5.41 V
P0657	Actuator Supply Voltage A Circuit/Open	Signal voltage, < 2.9 to 3.2 V
P0658	Actuator Supply Voltage A Circuit Low	Signal voltage, < 1.95 to 2.2 V
P0659	Actuator Supply Voltage A Circuit High	Signal current > 1.2 A
P0685	ECM/PCM Power Relay Control Circuit/Open	<ul style="list-style-type: none"> • Signal voltage 2.6 - 3.7 V • Sense circuit voltage > 6 V
P0686	ECM/PCM Power Relay Control Circuit Low	• Sense circuit voltage > 6.0 V
P0687	ECM/PCM Power Relay Control Circuit High	• Sense circuit voltage < 5.0 V

DTC	Error Message	Malfunction Criteria and Threshold Value
P0688	ECM/PCM Power Relay Sense Circuit	<ul style="list-style-type: none"> • Sense voltage < 3.0 V • Difference sense circuit voltage with camshaft actuator commanded off and on > 2.5 V • Battery voltage > 3 V
P0697	Sensor Reference Voltage C Circuit/Open	Signal voltage deviation > ± 0.3 V
P0698	Sensor Reference Voltage C Circuit Low	Signal voltage < 4.6 - 5.0 V
P0699	Sensor Reference Voltage C Circuit High	5V supply voltage > 4.99 - 5.41 V
U0001	High Speed CAN Communication Bus	CAN message, no feedback
U0002	High Speed CAN Communication Bus	Global time out...receiving no messages
U0100	Lost Communication with ECM/PCM A	<ul style="list-style-type: none"> • Failure of all CAN engine messages, time out > 490 mSec. • Failure of all CAN engine messages, but not all CAN messages, time out > 1010 mSec.
U0101	Lost Communication with TCM	No message received from TCM
U0121	CAN ABS Brake Unit	No CAN communication with TCU, time-out
U0140	CAN communication with BCM 1	CAN message no message
U0146	CAN Gateway A	CAN communication with gateway, implausible message
U0155	Communication with ICL	No CAN communication with ICL, time-out
U0302	Software Incompatibility with Transmission Control Module	MT vehicle ECM coded as AT vehicle
U0322	Communication with Body Control Module	Ambient temperature value (module not encoded for ambient temperature sensor) FDh
U0323	CAN: Instrument Cluster Audi Only	Ambient temperature value module not encoded for ambient temp sensor, 00h
U0402	CAN Communication with TCM	Invalid data received from TCM <ul style="list-style-type: none"> • Implausible message

DTC	Error Message	Malfunction Criteria and Threshold Value
U0404	Invalid Data Received From Gear Shift Control Module	<ul style="list-style-type: none"> • If the value of message counter is permanent, constant, or change exceeds a threshold, increment an event counter • Maximum change of message counter > 5
U0415	CAN Link to Speed Sensor	<ul style="list-style-type: none"> • Out of range: receiving fault value 203.5 mph • Out of range: receiving fault value > 202.81 mph • Out of range: receiving fault value < 1.24 mph
U0422	CAN: Instrument cluster	Ambient temperature value initialization, Audi 01 h
U0423	Communication with ICL	Invalid data received from ICL implausible message
U0447	Lost Communication With Gateway "B"	Received data from Gateway implausible message
U1103	Vehicle in production mode	Production mode = active

Fuel and Air Ratios Control Module

DTC	Error Message	Malfunction Criteria and Threshold Value
P10A0	Actuation Regulating Flap for Intake Air Electrical Error	<ul style="list-style-type: none"> • Duty cycle > 95 [%] and/or duty cycle < -95 [%] • Duty cycle > 0.3 s at > 98%
P10A4	Regulating Flap for Intake Air Mechanical Malfunction	<ul style="list-style-type: none"> • Diff. Adapted value vs. actual value > 6.5 [%] • Absolute value of maximum deviation between predicted and real value: > 8% • Adaptive value < 60 [%] and/or adaptive value > 88 [%]
P10A5	Potentiometer Regulating Flap for Intake Air Signal Too High	Signal voltage > 4.9 V
P10A6	Potentiometer Regulating Flap for Intake Air Signal Too Low	Signal voltage < 0.1 V
P10A7	Adaptation Regulating Flap for Intake Air Soiled	Difference actual signal voltage to learned signal voltage > 0.05 V

DTC	Error Message	Malfunction Criteria and Threshold Value
P10A8	Adaptation Regulating Flap For Intake Air Lower Limit Not Reached	RFP Signal Voltage in closed position ≤ 0.35 V or ≥ 0.65 V
P1114	Internal Resistance Too Large (Bank 1, Sensor 2)	Heater resistance, (128-648)*(8-40)1.02-25.9 k Ω (dep. on mod. exhaust temp. and heater power)
P12A1	Fuel Rail Pressure Sensor Inappropriately Low	<ul style="list-style-type: none"> • deviation fuel rail pressure control > 0.060 g/Rev and • Fuel trim activity < 0.85
P12A2	Fuel Rail Pressure Sensor Inappropriately High	<ul style="list-style-type: none"> • Deviation fuel rail pressure control < 0.051 g/Rev and • Deviation HO2S control $> 30\%$
P12A4	Fuel Rail Pressure Metering Valve Function Check Valve Stuck Closed	<ul style="list-style-type: none"> • Deviation fuel rail pressure control $< - 0.120$ g/rev • Lambda controller output (no map, just bottom and top limit) $-15 - 15\%$ • Actual pressure - target pressure >3.5 MPa • Lambda controller output (no map, just bottom and top limit) $-15 - 15\%$
P13EA	Cold Start Ignition Timing Performance Off Idle	Part Load Difference between commanded spark timing vs. actual value $> 15\%$
P150A	Engine Off Timer Performance	<ul style="list-style-type: none"> • Difference between engine-off-time $< - 12$ s • and ECM after run-time > 12 s
P169A	Loading Mode Active	Transport mode active
P2101	Throttle Actuator "A" Control Motor Circuit Range/ Performance	<ul style="list-style-type: none"> • Duty cycle > 0.4 s at $> 98\%$ • Actual TPS reference point $> 1.5^\circ$ • Actual TPS calc value > 0.4 s at $> 8^\circ$
P2106	Throttle Actuator Control System - Forced Limited Power	ECM power stage = failure
P2122	Throttle/Pedal Position Sensor/Switch "D" Circuit Low	Signal voltage < 0.4 V

DTC	Error Message	Malfunction Criteria and Threshold Value
P2123	Throttle/Pedal Position Sensor/Switch "D" Circuit High	Signal voltage >4.82 V
P2127	Throttle/Pedal Position Sensor/Switch "E" Circuit Low	Signal voltage < 0.2 V
P2128	Throttle/Pedal Position Sensor/Switch "E" Circuit High Input	Signal voltage > 2.8 V
P2138	Throttle/Pedal Position Sensor/Switch "D"/"E" Voltage Correlation	Signal voltage sensor 1 vs 2, > 0.24 V
P2147	Fuel Injector Group "A" Supply Voltage Circuit Low	Signal current > 12 A
P2148	Fuel Injector Group "A" Supply Voltage Circuit High	Signal current > 33 A
P2150	Fuel Injector Group "B" Supply Voltage Circuit Low	Signal current > 12 A
P2151	Fuel Injector Group "B" Supply Voltage Circuit High	Signal current > 33 A
P2153	Fuel Injector Group "C" Supply Voltage Circuit Low	Signal current > 12 A
P2154	Fuel Injector Group "C" Supply Voltage Circuit High	Signal current > 33 A
P2181	Cooling System Performance	<ul style="list-style-type: none"> • ECT < 75° C • Mass air integral 3.5 - 26.0 kg
P2195	HO2 Sensor Signal Biased/ Stuck Lean Bank 1 Sensor 1	HO2S value > 1.1 [-]
P2196	HO2 Sensor Signal Biased/ Stuck Rich Bank 1 Sensor 1	HO2S value < 0.9 [-]
P2197	HO2 Sensor Signal Biased/ Stuck Lean Bank 2 Sensor 1	HO2S value > 1.1 [-]
P2198	HO2 Sensor Signal Biased/ Stuck Rich Bank 2 Sensor 1	HO2S value < 0.9 [-]
P219C	Cylinder 1 Air-Fuel Ratio Imbalance	<ul style="list-style-type: none"> • Adaptive value < -10% or • > 10%
P219D	Cylinder 2 Air-Fuel Ratio Imbalance	<ul style="list-style-type: none"> • Adaptive value < -10% or • > 10%
P219E	Cylinder 3 Air-Fuel Ratio Imbalance	<ul style="list-style-type: none"> • Adaptive value < -10% or • > 10%

DTC	Error Message	Malfunction Criteria and Threshold Value
P219F	Cylinder 4 Air-Fuel Ratio Imbalance	<ul style="list-style-type: none"> • Adaptive value < -10% or • > 10%
P21A0	Cylinder 5 Air-Fuel Ratio Imbalance	<ul style="list-style-type: none"> • Adaptive value < -10% or • > 10%
P21A1	Cylinder 6 Air-Fuel Ratio Imbalance	<ul style="list-style-type: none"> • Adaptive value < -10% or • > 10%
P2227	Barometric Pressure Sensor "A" Circuit Range/ Performance	Press. diff. in cross-check between boost press. sensor 1/2; Intake Manifold press., ambient press. >7 kPa
P2237	HO2 Sensor Positive Current Control Circuit Open Bank 1, Sensor 1	<ul style="list-style-type: none"> • Signal activity check-failed • Open Circuit pump Current (IP)
P2240	HO2 Sensor Positive Current Control Circuit Open Bank 2, Sensor 1	<ul style="list-style-type: none"> • Signal activity check-failed • Open Circuit pump Current (IP)
P2243	HO2 Sensor Reference Voltage Circuit/Open Bank 1 Sensor 1	<ul style="list-style-type: none"> • Signal activity check-failed • Open Circuit Nernst Voltage (UN)
P2247	HO2 Sensor Reference Voltage Circuit/Open Bank 2 Sensor 1	<ul style="list-style-type: none"> • Signal activity check-failed • Open Circuit Nernst Voltage (UN)
P2251	HO2 Sensor Negative Current Control Circuit Open Bank 1, Sensor 1	<ul style="list-style-type: none"> • Signal activity check-failed • Open Circuit Virtual Mass (VM)
P2254	HO2 Sensor Negative Current Control Circuit Open Bank 2, Sensor 1	<ul style="list-style-type: none"> • Signal activity check-failed • Open Circuit Virtual Mass (VM)
P2257	Secondary Air Injection System Control "A" Circuit Low	Signal voltage < 2.00 V
P2258	Secondary Air Injection System Control "A" Circuit High	Signal current > 3 A
P2270	HO2 Sensor Signal Biased/ Stuck Lean Bank 1 Sensor 2	<ul style="list-style-type: none"> • Signal voltage < 0.750 V • Number of checks ≥ 2
P2271	HO2 Sensor Signal Biased/ Stuck Rich Bank 1 Sensor 2	<ul style="list-style-type: none"> • Signal voltage > 0.15 V • Number of checks ≥ 2

DTC	Error Message	Malfunction Criteria and Threshold Value
P2272	HO2 Sensor Signal Biased/ Stuck Lean Bank 2 Sensor 2	<ul style="list-style-type: none"> • Signal voltage < 0.750 V • Number of checks ≥ 2
P2273	HO2 Sensor Signal Biased/ Stuck Rich Bank 2 Sensor 2	<ul style="list-style-type: none"> • Signal voltage > 0.15 V • Number of checks ≥ 2
P2293	Fuel Pressure Regulator 2 Performance	<ul style="list-style-type: none"> • Difference between target pressure vs. actual pressure, > 1.50 mPa • Difference between target pressure vs. actual pressure, < -1.50 mPa
P2294	Fuel Pressure Regulator 2 Control Circuit Open Circuit	Signal current < 0.8 mA
P2295	Fuel Pressure Regulator 2 Control Circuit Low Short to Ground	< 2.0 V
P2296	Fuel Pressure Regulator 2 Control Circuit High	Signal current > 8 A

Ignition System

DTC	Error Message	Malfunction Criteria and Threshold Value
P2300	Ignition Coil A Primary Control Circuit Low	Signal current > 24.0 mA
P2301	Ignition Coil A Primary Control Circuit High	Signal current > 5.1 - 7.0 mA
P2303	Ignition Coil B Primary Control Circuit Low	Signal current > 24.0 mA
P2304	Ignition Coil B Primary Control Circuit High	Signal current > 5.1 - 7.0 mA
P2306	Ignition Coil C Primary Control Circuit Low	Signal current > 24.0 mA
P2307	Ignition Coil C Primary Control Circuit High	Signal voltage > 5.1 - 7.0 mA
P2309	Ignition Coil D Primary Control Circuit Low	Signal current > 24.0 mA
P2310	Ignition Coil D Primary Control Circuit High	Signal voltage > 5.1 - 7.0 mA

Additional Emissions Regulations

DTC	Error Message	Malfunction Criteria and Threshold Value
P2414	HO2 Sensor Exhaust Sample Error Bank 1, Sensor 1	O2S signal front > 3.1 V
P2415	HO2 Sensor Exhaust Sample Error Bank 2, Sensor 1	O2S signal front > 3.1 V
P2440	Secondary Air Injection System Switching Valve Stuck Open Bank 1	Deviation of lambda controller > 15.00%
P2442	Secondary Air Injection System Switching Valve Stuck Open Bank 2	Deviation of lambda controller > 15.00%
P2539	Low Pressure Fuel System Sensor Circuit	Signal voltage > 4.9 V
P2541	Low Pressure Fuel System Sensor Circuit Low	Signal voltage < 0.2 V
P2626	HO2 Sensor Pumping Current Trim Circuit Open Bank 1 Sensor 1	<ul style="list-style-type: none"> • O2S signal front > 4.7 V • Open Circuit Adjustment Voltage (IA)
P2629	HO2 Sensor Pumping Current Trim Circuit Open Bank 2 Sensor 1	<ul style="list-style-type: none"> • O2S signal front > 4.7 V • Open Circuit Adjustment Voltage (IA)

Transmission

DTC	Error Message	Malfunction Criteria and Threshold Value
P0705	Transmission Range Sensor Circuit Malfunction (PRNDL Input)	-
P0706	Transmission Range Sensor "A" Circuit Range/ Performance	4 bit position code, incorrect
P0707	Transmission Range Sensor Circuit Low	-
P0708	Transmission Range Sensor Circuit High	-
P0710	Transmission Fluid Temperature Sensor "A" Circuit	Sensor short circuit: <ul style="list-style-type: none"> • U_sensor (+), and U_sensor (-) diagnosis by ASIC

DTC	Error Message	Malfunction Criteria and Threshold Value
P0711	Transmission Fluid Temperature Sensor "A" Circuit Range/Performance	Discontinual temperature: <ul style="list-style-type: none"> • ATF temperature delta T between 2 measurements, > 20° C Sensor stuck: <ul style="list-style-type: none"> • Comparison ATF vs. chip temperature, ATF temp. must follow chip temp. in certain ranges, 25-40° C
P0712	Transmission Fluid Temperature Sensor "A" Circuit Low	Circuit low: <ul style="list-style-type: none"> • U_sensor (+), and U_sensor (-) diagnosis by ASIC
P0713	Transmission Fluid Temperature Sensor "A" Circuit High	Circuit high: <ul style="list-style-type: none"> • U_sensor (+), and U_sensor (-) diagnosis by ASIC
P0714	Transmission Fluid Temperature Sensor "A" Circuit Intermittent	Circuit high: <ul style="list-style-type: none"> • U_sensor (+), and U_sensor (-) diagnosis by ASIC
P0716	Input/Turbine Speed Sensor "A" Circuit Range/Performance	Signal higher or lower than threshold <ul style="list-style-type: none"> • Higher, > + 8000 RPM • Lower, < 20 RPM
P0717	Input/Turbine Speed Sensor "A" Circuit No Signal	Hardware detection
P0721	Input/Turbine Speed Sensor "A" Circuit No Signal	<ul style="list-style-type: none"> • Signal > threshold, > 10000 RPM • Difference between last and actual value >threshold, -1000 RPM • Difference to wheel speeds, > 500 RPM and input speed, > 200 RPM
P0722	Output Speed Sensor Circuit No Signal	Hardware detection
P0722	Engine Speed Input Circuit No Signal	CAN message signal error flag, =1
P0741	Torque Converter Clutch Circuit Performance or Stuck Off	Rate of (setting of nominal value) - actual value, > 50 RPM
P0746	Pressure Control Solenoid "A" Performance or Stuck Off	PWM hardware detection, 0 or 100%
P0747	Pressure Control Solenoid "A" Stuck On	PWM hardware detection, 0 or 100%

DTC	Error Message	Malfunction Criteria and Threshold Value
P0748	Pressure Control Solenoid "A" Electrical	<ul style="list-style-type: none"> • Current higher or lower than threshold, > 220 mA • EDS output voltage at short to ground or open circuit ~ 0,5 V smaller than EDS supply voltage • Static leakage current flow
P0751	Shift Solenoid "A" Performance or Stuck Off	<ul style="list-style-type: none"> • If PWM = 0%, diagnosis by ASIC • If $0\% \leq \text{PWM}$, 7.6% voltage return lead (low), < 0.75 V • If $7.6\% \leq \text{PWM}$, 92.4% voltage return lead (high), < 0.75 V • If $7.6\% \leq \text{PWM}$, 92.4% voltage return lead (low), < 0.75 V
P0752	Shift Solenoid "A" Stuck On	<ul style="list-style-type: none"> • If PWM = 100%, diagnosis by ASIC • If $7.6\% \leq \text{PWM} \leq 100\%$ voltage return lead (high), >0.3 V
P0754	Shift Solenoid "A" Intermittent	<ul style="list-style-type: none"> • If PWM = 0%, diagnosis by ASIC • If $0\% \leq \text{PWM}$, 7.6% voltage return lead (low), < 0.75 V • If $7.6\% \leq \text{PWM}$, 92.4% voltage return lead (high), < 0.75 V • If $7.6\% \leq \text{PWM}$, 92.4% voltage return lead (low), < 0.75 V
P0776	Pressure Control Solenoid "B" Performance or Stuck Off	PWM hardware detection, 0 or 100%
P0777	Pressure Control Solenoid "B" Stuck On	PWM hardware detection, 0 or 100%
P0778	Pressure Control Solenoid "B" Electrical	<ul style="list-style-type: none"> • Current higher or lower than threshold, <730 mA • EDS output voltage at short to ground or open circuit ~ 0,5 V smaller than EDS supply voltage • Static leakage current flow
P0796	Pressure Control Solenoid "C" Performance or Stuck Off	PWM hardware detection, 0 or 100%
P0797	Pressure Control Solenoid "C" Stuck On	PWM hardware detection, 0 or 100%

DTC	Error Message	Malfunction Criteria and Threshold Value
P0798	Pressure Control Solenoid "C" Electrical	<ul style="list-style-type: none"> • Current higher or lower than threshold, > 220 mA • DS output voltage at short to ground or open circuit ~ 0.5 V smaller than EDS supply voltage • Static leakage current flow
P0889	TCM Power Relay Circuit Range / Performance	FET drive, not possible
P0890	TCM Power Relay Circuit Low	<ul style="list-style-type: none"> • Solenoid power supply voltage, <1.4 V • Drop voltage over high side FET, > 1 V
P0891	TCM Power Relay Circuit High	Hardware detection
P0892	TCM Power Relay Circuit Intermittent	Hardware detection
P2637	Torque management Feedback Signal "A"	CAN message signal error flag, = 1
P2714	Pressure Control Solenoid "D" Performance or Stuck Off	PWM hardware detection, 0 or 100%
P2715	Pressure Control Solenoid "D" Stuck On	PWM hardware detection, 0 or 100%
P2716	Pressure Control Solenoid "D" Electrical	<ul style="list-style-type: none"> • Current higher or lower than threshold, < 730 mA • EDS output voltage at short to ground or open circuit ~ 0.5 V smaller than EDS supply voltage • Static leakage current flow
P2723	Pressure Control Solenoid "E" Performance or Stuck off	PWM hardware detection, 0 or 100%
P2725	Pressure Control Solenoid "E" Electrical	<ul style="list-style-type: none"> • Current higher or lower than threshold, < 730 mA • EDS output voltage at short to ground or open circuit ~ 0.5 V smaller than EDS supply voltage • Static leakage current flow
P2732	Pressure Control Solenoid "F" Performance or Stuck Off	PWM hardware detection, 0 or 100%
P2733	Pressure Control Solenoid "F" Stuck On	PWM hardware detection, 0 or 100%

DTC	Error Message	Malfunction Criteria and Threshold Value
P2734	Pressure Control Solenoid "F" Electrical	<ul style="list-style-type: none"> • EDS output voltage at short to ground or open circuit ~ 0.5 V smaller than EDS supply voltage • Static leakage current flow
P2735	Pressure Control Solenoid "F" Intermittent	PWM hardware detection, 0 or 100%

Audi of America reserves the right to change or update any part of this technical manual at any time. No legal commitment can therefore be derived from the information, illustrations or descriptions in this manual.

The texts, illustrations and standards in this manual are based on the information available at the time of printing. No part of this manual may be reprinted, reproduced or translated without the written permission of Audi of America.

All rights under the copyright laws are expressly reserved by Audi of America. Subject to alteration and amendment.

**Printed in the United States
© 2013 Audi of America, Inc.**

