

# SPECIFICATIONS

## FIGURE 7866

### HANGERS, CLAMPS & STRAPS



#### 2-HOLE PIPE STRAP

FNW Figure 7866 2-hole pipe straps are made in the USA and designed for use when securing pipe, tubing and conduit to strut channel along with standard surface mounting applications. These 2-hole straps come stock with an electro-galvanized finish.

**MADE IN THE  
USA**

| Catalog Number | Pipe Size |     | HS   |      | CL      |       | Wt.  |
|----------------|-----------|-----|------|------|---------|-------|------|
|                | in.       | mm  | in.  | mm   | in.     | mm    | lbs  |
| FNW7866Z0050   | 1/2       | 15  | 5/16 | 7.9  | 1-1/8   | 23.8  | 0.23 |
| FNW7866Z0075   | 3/4       | 20  | 5/16 | 7.9  | 1-3/16  | 25.4  | 0.26 |
| FNW7866Z0100   | 1         | 25  | 5/16 | 7.9  | 1-5/16  | 28.6  | 0.29 |
| FNW7866Z0125   | 1-1/4     | 32  | 5/16 | 7.9  | 1-7/16  | 33.3  | 0.34 |
| FNW7866Z0150   | 1-1/2     | 40  | 5/16 | 7.9  | 1-9/16  | 36.5  | 0.37 |
| FNW7866Z0200   | 2         | 50  | 7/16 | 11.1 | 2-1/8   | 54    | 0.92 |
| FNW7866Z0250   | 2-1/2     | 65  | 7/16 | 11.1 | 2-3/8   | 60.3  | 1.08 |
| FNW7866Z0300   | 3         | 80  | 7/16 | 11.1 | 2-11/16 | 68.3  | 1.33 |
| FNW7866Z0350   | 3-1/2     | 90  | 7/16 | 11.1 | 2-15/16 | 74.6  | 1.43 |
| FNW7866Z0400   | 4         | 100 | 9/16 | 14.2 | 3-3/16  | 81    | 1.66 |
| FNW7866Z0500   | 5         | 125 | 9/16 | 14.2 | 3-3/4   | 95.2  | 1.95 |
| FNW7866Z0600   | 6         | 150 | 9/16 | 14.2 | 4-1/4   | 107.9 | 2.27 |

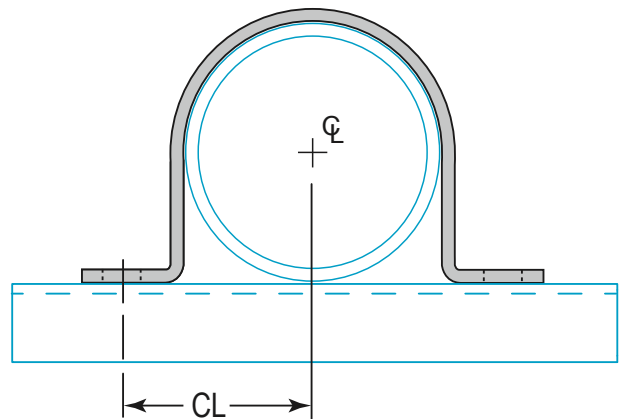
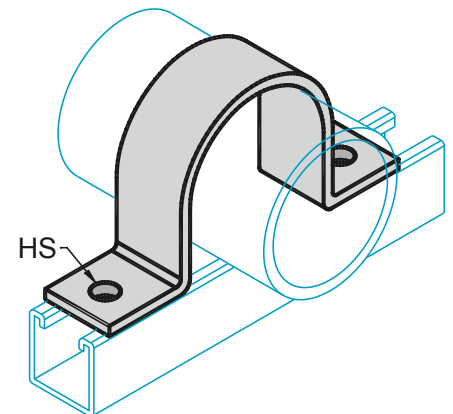

#### MATERIAL SPECIFICATIONS AND FINISHES

Carbon Steel – ASTM A1011-00 SS GR 33 or ASTM A1011-00CS Type B

**Z:** Electro-Galvanized (standard finish). Electroplating deposits zinc on the surface of the steel by electrolysis from a bath of zinc salts. Recommended for relatively dry indoor use.

This is the standard coating for most FNW products. Thickness of applied zinc is between 0.2 mils to 0.5 mils [5.1 μm to 12.7 μm]. Coatings on FNW Z products meet ASTM B633 SC1 Type III.

**HD:** Hot Dip Galvanized After Fabrication. Fabricated product is dipped in molten zinc and is completely covered on all surfaces. Recommended for outdoor use. Coatings on FNW HD products meet ASTM A123/153. The zinc coating is typically 2.6 mils [66.0 μm] or 1.5 oz. per square foot [0.46 kg per square meter] per side.

**S4:** 304 Stainless Steel – ASTM A240 (Type 304)

**S6:** 316 Stainless Steel – ASTM A240 (Type 316), 316 Stainless Steel Nuts – ASTM A276-03

**Y:** Yellow Zinc Dichromate. A 0.5 mil [12.7 μm] electro-galvanized zinc plating meeting ASTM B633 SC1 Type III is applied to the surface of the metal. Yellow dichromate is applied over the zinc. This results in a yellowish gold appearance and acts as a nonporous barrier sealant that is corrosion resistant and can be painted.