

Edition

04/2024

EQUIPMENT MANUAL

SIMATIC

ET 200SP

Digital output module
DQ 8x24VDC/0.5A HF (6ES7132-6BF01-0CA0)

support.industry.siemens.com

SIEMENS

SIMATIC

ET 200SP

Digital output module
DQ 8x24VDC/0.5A HF
(6ES7132-6BF01-0CA0)

Equipment Manual

Introduction

1

Industrial cybersecurity

2

Product overview

3

Wiring

4

Parameters/address space

5

Interrupts/diagnostics alarms

6

Technical specifications

7



Parameter data record

A

Legal information

Warning notice system

This manual contains notices you have to observe in order to ensure your personal safety, as well as to prevent damage to property. The notices referring to your personal safety are highlighted in the manual by a safety alert symbol, notices referring only to property damage have no safety alert symbol. These notices shown below are graded according to the degree of danger.

 DANGER
indicates that death or severe personal injury will result if proper precautions are not taken.
 WARNING
indicates that death or severe personal injury may result if proper precautions are not taken.
 CAUTION
indicates that minor personal injury can result if proper precautions are not taken.
NOTICE
indicates that property damage can result if proper precautions are not taken.

If more than one degree of danger is present, the warning notice representing the highest degree of danger will be used. A notice warning of injury to persons with a safety alert symbol may also include a warning relating to property damage.

Qualified Personnel

The product/system described in this documentation may be operated only by **personnel qualified** for the specific task in accordance with the relevant documentation, in particular its warning notices and safety instructions. Qualified personnel are those who, based on their training and experience, are capable of identifying risks and avoiding potential hazards when working with these products/systems.

Proper use of Siemens products

Note the following:

 WARNING
Siemens products may only be used for the applications described in the catalog and in the relevant technical documentation. If products and components from other manufacturers are used, these must be recommended or approved by Siemens. Proper transport, storage, installation, assembly, commissioning, operation and maintenance are required to ensure that the products operate safely and without any problems. The permissible ambient conditions must be complied with. The information in the relevant documentation must be observed.

Trademarks

All names identified by ® are registered trademarks of Siemens Aktiengesellschaft. The remaining trademarks in this publication may be trademarks whose use by third parties for their own purposes could violate the rights of the owner.

Disclaimer of Liability

We have reviewed the contents of this publication to ensure consistency with the hardware and software described. Since variance cannot be precluded entirely, we cannot guarantee full consistency. However, the information in this publication is reviewed regularly and any necessary corrections are included in subsequent editions.

Table of contents

1	Introduction.....	5
1.1	ET 200SP Documentation Guide.....	6
1.1.1	Information classes ET 200SP.....	6
1.1.2	Basic tools.....	8
1.1.3	MultiFieldbus Configuration Tool (MFCT).....	10
1.1.4	SIMATIC Technical Documentation.....	11
2	Industrial cybersecurity.....	13
2.1	Introduction to industrial cybersecurity.....	13
2.2	Cybersecurity information.....	13
3	Product overview.....	14
3.1	Properties.....	14
4	Wiring.....	17
4.1	Wiring diagram.....	17
4.2	Block diagram.....	20
5	Parameters/address space.....	21
5.1	Parameters.....	21
5.2	Explanation of parameters.....	23
5.3	Address space.....	25
6	Interrupts/diagnostics alarms.....	32
6.1	Status and error displays.....	32
6.2	Interrupts.....	33
6.3	Diagnostics alarms.....	34
7	Technical specifications.....	35
7.1	Technical specifications.....	35
A	Parameter data record.....	40
A.1	Parameter assignment and structure of parameter data record.....	40
A.2	Error codes.....	43

Introduction

Purpose of the documentation

This manual supplements the System Manual ET 200SP distributed I/O system (<https://support.automation.siemens.com/WW/view/en/58649293>).

Functions that generally relate to the system are described in the system manual.

The information provided in this manual and in the system/function manuals supports you in commissioning the system.

Conventions

CPU: When the term "CPU" is used in the following, it applies to the CPUs of the S7-1500 automation system as well as to the CPUs/interface modules of the ET 200SP distributed I/O system.

STEP 7: In this documentation, "STEP 7" is used as a synonym for all versions of the configuration and programming software "STEP 7 (TIA Portal)".

Also observe notes marked as follows:

NOTE

A note contains important information on the product described in the documentation, on the handling of the product and on the section of the documentation to which particular attention should be paid.

Recycling and disposal

For environmentally sustainable recycling and disposal of your old equipment, contact a certified electronic waste disposal company and dispose of the equipment according to the applicable regulations in your country.

1.1 ET 200SP Documentation Guide

1.1.1 Information classes ET 200SP



The documentation for the SIMATIC ET 200SP distributed I/O system is arranged into three areas.

This arrangement enables you to access the specific content you require.

You can download the documentation free of charge from the Internet

(<https://support.industry.siemens.com/cs/ww/en/view/109742709>).

Basic information



The System Manual describes in detail the configuration, installation, wiring and commissioning of the SIMATIC ET 200SP distributed I/O system.

The STEP 7 online help supports you in the configuration and programming.

Examples:

- ET 200SP System Manual
- System Manual ET 200SP HA/ET 200SP modules for devices used in a hazardous area
- Online help TIA Portal

Device information



Equipment manuals contain a compact description of the module-specific information, such as properties, wiring diagrams, characteristics and technical specifications.

Examples:

- Equipment Manuals CPUs
- Equipment Manuals Interface Modules
- Equipment Manuals Digital Modules
- Equipment Manuals Analog Modules
- Equipment Manuals Motor Starter
- BaseUnits Equipment Manuals
- Equipment Manual Server Module
- Equipment Manuals Communications Modules
- Equipment Manuals Technology Modules

General information



The function manuals contain detailed descriptions on general topics relating to the SIMATIC ET 200SP distributed I/O system.

Examples:

- Function Manual ET 200AL/ET 200SP Mixed Configuration
- Function Manual Diagnostics
- Function Manual Communication
- PROFINET Function Manual
- PROFIBUS Function Manual
- Function Manual Designing Interference-free Controllers
- MultiFieldbus Function Manual

Product Information

Changes and supplements to the manuals are documented in a Product Information. The Product Information takes precedence over the device and system manuals. You can find the latest Product Information on the ET 200SP distributed I/O system on the Internet. (<https://support.industry.siemens.com/cs/de/en/view/73021864>)

Manual Collection ET 200SP

The Manual Collection contains the complete documentation on the SIMATIC ET 200SP distributed I/O system gathered together in one file.

You can find the Manual Collection on the Internet.

(<https://support.industry.siemens.com/cs/cn/en/view/84133942>)

Manual Collection fail-safe modules

The Manual Collection contains the complete documentation on the fail-safe SIMATIC modules, gathered together in one file.

You can find the Manual Collection on the Internet.

(<https://support.industry.siemens.com/cs/ww/en/view/109806400>)

1.1.2 Basic tools

Tools

The tools described below support you in all steps: from planning, over commissioning, all the way to analysis of your system.

TIA Selection Tool

The TIA Selection Tool tool supports you in the selection, configuration, and ordering of devices for Totally Integrated Automation (TIA).

As successor of the SIMATIC Selection Tools, the TIA Selection Tool assembles the already known configurators for automation technology into a single tool.

With the TIA Selection Tool, you can generate a complete order list from your product selection or product configuration.

You can find the TIA Selection Tool on the Internet.

(<https://support.industry.siemens.com/cs/ww/en/view/109767888>)

SIMATIC Automation Tool

You can use the SIMATIC Automation Tool to perform commissioning and maintenance activities on various SIMATIC S7 stations as bulk operations independent of TIA Portal.

The SIMATIC Automation Tool offers a wide range of functions:

- Scanning of a PROFINET/Ethernet system network and identification of all connected CPUs
- Assignment of addresses (IP, subnet, Gateway) and device name (PROFINET device) to a CPU
- Transfer of the date and the programming device/PC time converted to UTC time to the module
- Program download to CPU
- RUN/STOP mode switchover
- CPU localization through LED flashing
- Reading out of CPU error information
- Reading the CPU diagnostic buffer
- Reset to factory settings
- Firmware update of the CPU and connected modules

You can find the SIMATIC Automation Tool on the Internet.

(<https://support.industry.siemens.com/cs/ww/en/view/98161300>)

PRONETA

SIEMENS PRONETA (PROFINET network analysis) is a commissioning and diagnostic tool for PROFINET networks. PRONETA Basic has two core functions:

- In the network analysis, you get an overview of the PROFINET topology. Compare a real configuration with a reference installation or make simple parameter changes, e.g. to the names and IP addresses of the devices.
- The "IO test" is a simple and rapid test of the wiring and the module configuration of a plant, including documentation of the test results.

You can find SIEMENS PRONETA Basic on the Internet:

(<https://support.industry.siemens.com/cs/ww/en/view/67460624>)

SIEMENS PRONETA Professional is a licensed product that offers you additional functions. It offers you simple asset management in PROFINET networks and supports operators of automation systems in automatic data collection/acquisition of the components used through various functions:

- The user interface (API) offers an access point to the automation cell to automate the scan functions using MQTT or a command line.
- With PROFlenergy diagnostics, you can quickly detect the current pause mode or the readiness for operation of devices that support PROFlenergy and change these as needed.
- The data record wizard supports PROFINET developers in reading and writing acyclic PROFINET data records quickly and easily without PLC and engineering.

You can find SIEMENS PRONETA Professional on the Internet.

(<https://www.siemens.com/proneta-professional>)

SINETPLAN

SINETPLAN, the Siemens Network Planner, supports you in planning automation systems and networks based on PROFINET. The tool facilitates professional and predictive dimensioning of your PROFINET installation as early as in the planning stage. In addition, SINETPLAN supports you during network optimization and helps you to exploit network resources optimally and to plan reserves. This helps to prevent problems in commissioning or failures during productive operation even in advance of a planned operation. This increases the availability of the production plant and helps improve operational safety.

The advantages at a glance

- Network optimization thanks to port-specific calculation of the network load
- Increased production availability thanks to online scan and verification of existing systems
- Transparency before commissioning through importing and simulation of existing STEP 7 projects
- Efficiency through securing existing investments in the long term and the optimal use of resources

You can find SINETPLAN on the Internet

(<https://new.siemens.com/global/en/products/automation/industrial-communication/profinet/sinetplan.html>).

1.1.3 MultiFieldbus Configuration Tool (MFCT)

MultiFieldbus Configuration Tool

MultiFieldbus Configuration Tool (MFCT) is a PC-based software and supports the configuration of MultiFieldbus- and DALI-devices. In addition, the MFCT offers convenient options for mass firmware updates of ET 200 devices with MultiFieldbus- support and reading service data for many other Siemens devices.

Functional scope of the MFCT

- MultiFieldbus configuration:
Engineering, configuration and diagnostics of MultiFieldbus-devices, provision of the required project files (project, UDT-, CSV- and EDS-file), transfer/export of the files to device and/or data memory.
- DALI configuration:
Device selection and online configuration of DALI devices.
- TM FAST:
Generation and download of FPGA-UPD- and FPGA-DB-files.
- Maintenance:
Topology scan of a Ethernet network, reading of service data, parameter assignment and firmware update.
- Settings:
Language switching German / English, network scanner speed, setting of the network adapter, installation of GSDML-and EDS-files.

System/installation requirements for MFCT

The MFCT runs under Microsoft Windows and does not require installation or administrator rights.

For MFCT you must also install the following software:

- Microsoft .NET Framework 4.8 (You can find an Offline Installer on the Internet. (<https://support.microsoft.com/en-us/topic/microsoft-net-framework-4-8-offline-installer-for-windows-9d23f658-3b97-68ab-d013-aa3c3e7495e0>))
- Npcap from directory "Misc"
- PG/PC interface from directory "Misc"
- Microsoft C++ Redistributable for x86-systems (you can find the installation data for download on the Internet. (https://aka.ms/vs/15/release/vc_redist.x86.exe))

The download of the tool and further information as well as documentation on the individual functions of the MFCT can be found on the Internet.

(<https://support.industry.siemens.com/cs/de/en/view/109773881>)

1.1.4 SIMATIC Technical Documentation

Additional SIMATIC documents will complete your information. You can find these documents and their use at the following links and QR codes.

The Industry Online Support gives you the option to get information on all topics. Application examples support you in solving your automation tasks.

Overview of the SIMATIC Technical Documentation

Here you will find an overview of the SIMATIC documentation available in Siemens Industry Online Support:



Industry Online Support International

<https://support.industry.siemens.com/cs/ww/en/view/109742705>

Watch this short video to find out where you can find the overview directly in Siemens Industry Online Support and how to use Siemens Industry Online Support on your mobile device:



Quick introduction to the technical documentation of automation products per video <https://support.industry.siemens.com/cs/us/en/view/109780491>



YouTube video: Siemens Automation Products - Technical Documentation at a Glance <https://youtu.be/TwLSxxRQQsA>

Retention of the documentation

Retain the documentation for later use.

For documentation provided in digital form:

1. Download the associated documentation after receiving your product and before initial installation/commissioning. Use the following download options:

- Industry Online Support International: <https://support.industry.siemens.com>

The article number is used to assign the documentation to the product. The article number is specified on the product and on the packaging label. Products with new, non-compatible functions are provided with a new article number and documentation.

- ID link:

Your product may have an ID link. The ID link is a QR code with a frame and a black frame corner at the bottom right. The ID link takes you to the digital nameplate of your product. Scan the QR code on the product or on the packaging label with a smartphone camera, barcode scanner, or reader app. Call up the ID link.

2. Retain this version of the documentation.

Updating the documentation

The documentation of the product is updated in digital form. In particular in the case of function extensions, the new performance features are provided in an updated version.

1. Download the current version as described above via the Industry Online Support or the ID link.
2. Also retain this version of the documentation.

mySupport

With "mySupport" you can get the most out of your Industry Online Support.

Registration	You must register once to use the full functionality of "mySupport". After registration, you can create filters, favorites and tabs in your personal workspace.
Support requests	Your data is already filled out in support requests, and you can get an overview of your current requests at any time.
Documentation	In the Documentation area you can build your personal library.
Favorites	You can use the "Add to mySupport favorites" to flag especially interesting or frequently needed content. Under "Favorites", you will find a list of your flagged entries.
Recently viewed articles	The most recently viewed pages in mySupport are available under "Recently viewed articles".
CAX data	The CAX data area gives you access to the latest product data for your CAX or CAE system. You configure your own download package with a few clicks: <ul style="list-style-type: none"> • Product images, 2D dimension drawings, 3D models, internal circuit diagrams, EPLAN macro files • Manuals, characteristics, operating manuals, certificates • Product master data

You can find "mySupport" on the Internet. (<https://support.industry.siemens.com/My/ww/en>)

Application examples

The application examples support you with various tools and examples for solving your automation tasks. Solutions are shown in interplay with multiple components in the system - separated from the focus on individual products.

You can find the application examples on the Internet.
(<https://support.industry.siemens.com/cs/ww/en/ps/ae>)

Industrial cybersecurity

2.1 Introduction to industrial cybersecurity

Digitalization and the increasing networking of machines and industrial plants are also increasing the risk of cyberattacks. Appropriate protective measures are therefore mandatory, particularly in the case of critical infrastructure facilities.

Refer to the general information and measures on the subject of industrial cybersecurity in the ET 200SP Distributed I/O System

(<https://support.industry.siemens.com/cs/ww/en/view/58649293>) System Manual.

This section provides an overview of security-relevant information pertaining to your SIEMENS device.

2.2 Cybersecurity information

Siemens provides products and solutions with industrial cybersecurity functions that support the secure operation of plants, systems, machines, and networks.

In order to protect plants, systems, machines, and networks against cyber threats, it is necessary to implement – and continuously maintain – a holistic, state-of-the-art industrial cybersecurity concept. Siemens' products and solutions constitute one element of such a concept.

Customers are responsible for preventing unauthorized access to their plants, systems, machines and networks. Such systems, machines and components should only be connected to an enterprise network or the internet if and to the extent such a connection is necessary and only when appropriate security measures (e.g. firewalls and/or network segmentation) are in place.

For more information on protective industrial cybersecurity measures for implementation, please visit (<https://www.siemens.com/global/en/products/automation/topic-areas/industrial-cybersecurity.html>).

Siemens' products and solutions undergo continuous development to make them more secure. Siemens strongly recommends that product updates are applied as soon as they are available and that the latest product versions are used. Use of product versions that are no longer supported, and failure to apply the latest updates may increase customers' exposure to cyber threats.

To stay informed about product updates at all times, subscribe to the Siemens Industrial Cybersecurity RSS Feed under

(<https://new.siemens.com/global/en/products/services/cert.html>).

Product overview

3.1 Properties

Article number

6ES7132-6BF01-0CA0 (packing unit: 1 unit)
 6ES7132-6BF01-2CA0 (packing unit: 10 units)

View of the module

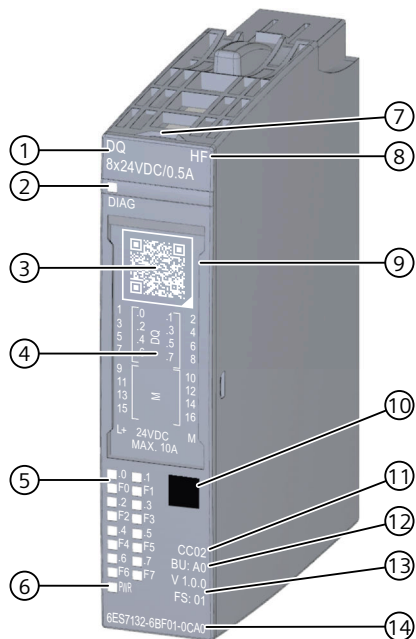

- | | |
|--|---|
| ① Module type and name | ⑧ Function class |
| ② LED for diagnostics | ⑨ Insertion option for optional labeling strip |
| ③ QR code for identification link | ⑩ Color coding module type |
| ④ Wiring diagram | ⑪ Color code for selecting the color-coded labels |
| ⑤ LEDs for channel statuses and channel errors | ⑫ BU type |
| ⑥ LED for supply voltage | ⑬ Firmware and function versions |
| ⑦ Slot for optional equipment labeling plate | ⑭ Article number |

Figure 3-1 View of module DQ 8x24VDC/0.5A HF

Properties

The module has the following technical properties:

- Digital output module with 8 outputs
- Source output (PNP, P-switching)
- Supply voltage L+
- Output current 0.5 A (per channel)
- Total current maximum 4 A
See Technical specifications (Page 35)
- Configurable diagnostics (per channel)
- Configurable substitute values (per channel)
- Suitable for solenoid valves, DC contactors, and indicator lights
- Extended spare parts compatibility (see Product information (<https://support.industry.siemens.com/cs/ww/en/view/73021864>))

The module supports the following functions:

Table 3-1 Version dependencies of the functions

Function	HW version	FW version	STEP 7		GSD file	
			TIA Portal	V5.x	PROFINET IO	PROFIBUS DP
Firmware update	FS01	V1.0.0 or higher	V19 or higher with HSP0428	V5.5 SP3 or higher with HSP 0230 from V11.0	X	X
I&M0 to I&M3 identification data	FS01	V1.0.0 or higher	V19 or higher with HSP0428	V5.5 SP3 or higher with HSP 0230 from V11.0	X	X
Parameter reassignment in RUN	FS01	V1.0.0 or higher	V19 or higher with HSP0428	V5.5 SP3 or higher with HSP 0230 from V11.0	X	X
PROFenergy	FS01	V1.0.0 or higher	V19 or higher with HSP0428	V5.5 SP3 or higher with HSP 0230 from V11.0	X	-
Value status	FS01	V1.0.0 or higher	V19 or higher with HSP0428	V5.5 SP3 or higher with HSP 0230 from V11.0	X	X
Isochronous mode	FS01	V1.0.0 or higher	V19 or higher with HSP0428	V5.5 SP3 or higher with HSP 0230 from V11.0	X	-
Module-internal shared output (MSO)	FS01	V1.0.0 or higher	V19 or higher with HSP0428	V5.5 SP3 or higher with HSP 0230 from V11.0	X	-
Configurable submodules/submodules for shared devices	FS01	V1.0.0 or higher	V19 or higher with HSP0428	V5.5 SP3 or higher with HSP 0230 from V11.0	X	-

Accessories

The following accessories are available optionally:

- Labeling strips
- Color identification labels
- Reference identification label
- Shield connector

See also

You can find more information on accessories in the ET 200SP Distributed I/O System (<https://support.industry.siemens.com/cs/ww/en/view/58649293>) System Manual.

Wiring

4.1 Wiring diagram

This section contains the pin assignment for the module.

You can find information on wiring the BaseUnit in the ET 200SP distributed I/O system (<http://support.automation.siemens.com/WW/view/en/58649293>) System Manual.

NOTE

The load group of the module must begin with a light-colored BaseUnit. Keep this in mind also during the configuration.

NOTICE

You may only use the digital output module with a BaseUnit type A0.
With the BaseUnit type A1, the integrated fuse can be triggered, rendering the terminals unusable.

NOTE

Cross-circuit at output

Note that a voltage applied at the output due to a cross-circuit can lead to the modules being supplied with L+.

Pin assignment: 1 and 2-wire connection of actuators

The following table shows an example of the pin assignment of digital output module DQ 8x24VDC/0.5A HF on the BaseUnit BU type A0 without AUX terminals:

Description	Signal	Terminal	BaseUnit BU type A0	Terminal	Signal	Description
Digital output, channel 0	DQ ₀	1		2	DQ ₁	Digital output, channel 1
Digital output, channel 2	DQ ₂	3		4	DQ ₃	Digital output, channel 3
Digital output, channel 4	DQ ₄	5		6	DQ ₅	Digital output, channel 5
Digital output, channel 6	DQ ₆	7		8	DQ ₇	Digital output, channel 7
Ground	M	9		10	M	Ground
Ground	M	11		12	M	Ground

¹⁾ Infeed only with light BaseUnit

4.1 Wiring diagram

Description	Signal	Terminal	BaseUnit BU type A0	Terminal	Signal	Description	
Ground	M	13		14	M	Ground	
Ground	M	15		16	M	Ground	
24 V DC supply voltage ¹⁾	L+	17		18	M	Ground	

¹⁾ Infeed only with light BaseUnit

NOTICE
<p>Current load of combined return conductors</p> <p>When connecting in 2-wire connection, the static current load of the combined return conductor must not exceed 2A per terminal.</p>

Pin assignment: 3-wire connection of actuators

The following table shows an example of the pin assignment of digital output module DQ 8x24VDC/0.5A HF on the BaseUnit BU type A0 with AUX terminals.

Description	Signal	Terminal	BaseUnit BU type A0	Terminal	Signal	Description
Digital output, channel 0	DQ ₀	1		2	DQ ₁	Digital output, channel 1
Digital output, channel 2	DQ ₂	3		4	DQ ₃	Digital output, channel 3
Digital output, channel 4	DQ ₄	5		6	DQ ₅	Digital output, channel 5
Digital output, channel 6	DQ ₆	7		8	DQ ₇	Digital output, channel 7
Ground	M	9		10	M	Ground
Ground	M	11		12	M	Ground
Ground	M	13		14	M	Ground
Ground	M	15		16	M	Ground
AUX terminal	AUX	1A	2A	AUX	AUX terminal	
AUX terminal	AUX	3A	4A	AUX	AUX terminal	
AUX terminal	AUX	5A	6A	AUX	AUX terminal	

¹⁾ Infeed only with light BaseUnit

Description	Signal	Terminal	BaseUnit BU type A0	Terminal	Signal	Description
AUX terminal	AUX	7A		8A	AUX	AUX terminal
AUX terminal	AUX	9A		10A	AUX	AUX terminal
24 V DC supply voltage ¹⁾	L+	L+		M	M	Ground

¹⁾ Infeed only with light BaseUnit

Output connection types

1-wire connection of actuators	2-wire connection of actuators	3-wire connection of actuators

You can also connect the ground and functional grounding via a potential distribution module (PotDis module) or AUX terminals. More information on potential distribution modules is available in the BaseUnits Equipment Manual (<https://support.industry.siemens.com/cs/ww/en/view/59753521>).

NOTE

You can use and combine the different wiring options for all channels.

4.2 Block diagram

This section contains the schematic circuit diagram of the module.

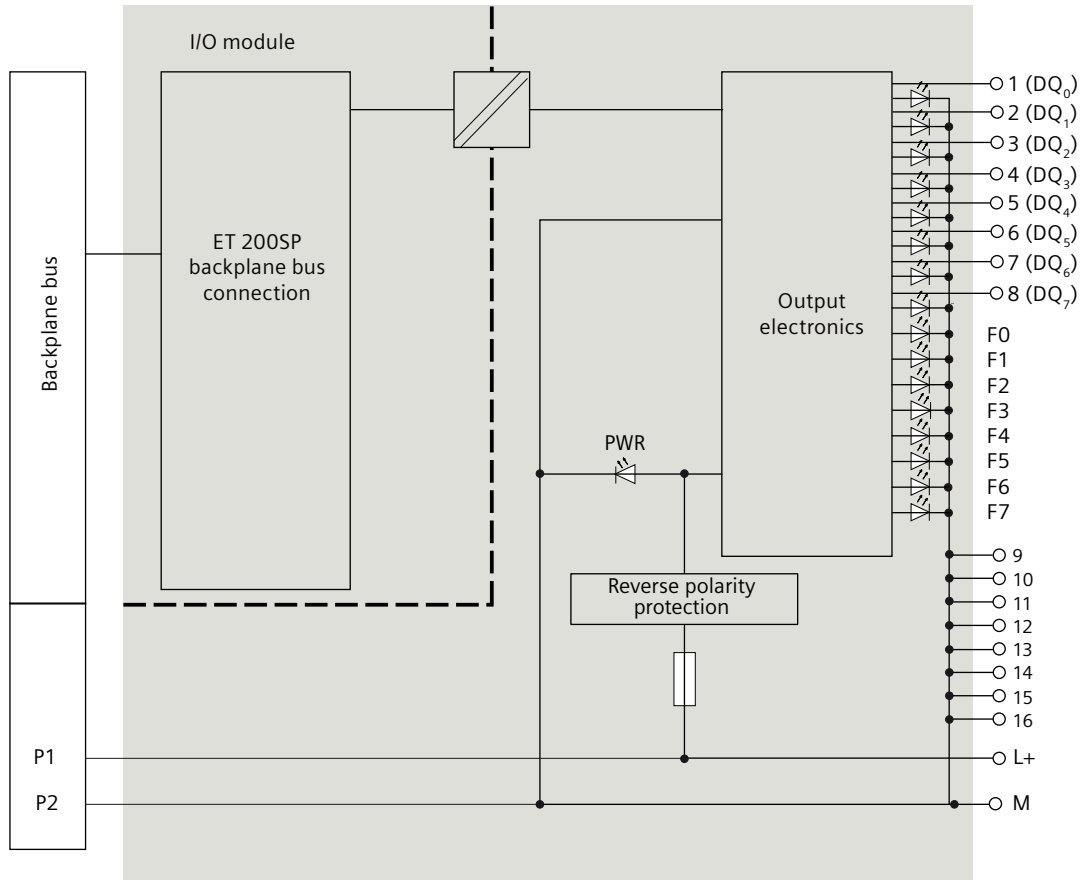

Figure 4-1 Schematic circuit diagram

Parameters/address space

5.1 Parameters

Parameters for DQ 8x24VDC/0.5A HF

Specify the module properties with the various parameters in the course of your STEP 7 configuration. The following table lists the configurable parameters. The effective range of the configurable parameters depends on the type of configuration.

The following configurations are possible:

- Central operation on an ET 200SP-CPU or on an ET 200SP Open Controller
- Distributed operation on PROFINET IO in an ET 200SP system
- Distributed operation with PROFIBUS DP in an ET 200SP system

In addition to parameter assignment via the configuration software, you can also configure parameters in RUN mode (dynamically) via the user program. When assigning parameters in the user program, use the "WRREC" instruction to transfer the parameters to the module by means of data records. See the Parameter assignment and structure of the parameter data record (Page 40) section.

The following parameter settings are possible:

Table 5-1 Configurable parameters and their defaults (GSD file)

Parameter	Value range	Default	Parameter reassignment during RUN	Effective range with configuration software, e.g. STEP 7 (TIA Portal)	
				GSD file PROFINET IO	GSD file PROFIBUS DP
Diagnostics No supply voltage L+	<ul style="list-style-type: none"> • Disable • Enable 	Disable	Yes	Channel	Channel
Diagnostics Short-circuit to ground	<ul style="list-style-type: none"> • Disable • Enable 	Disable	Yes	Channel	Channel ¹
Diagnostics: Short-circuit to L+	<ul style="list-style-type: none"> • Disable • Enable 	Disable	Yes	Channel	
Check for wire break	<ul style="list-style-type: none"> • Disable • Enable 	Enable	Yes	Channel	Channel
Diagnostics Wire break	<ul style="list-style-type: none"> • Disable • Enable 	Disable	Yes	Channel	Channel

¹ Due to the limited number of parameters at a maximum of 244 bytes per ET 200SP station with a PROFIBUS GSD configuration, the possible parameter settings are restricted. The parameter length of the I/O module is 8 bytes for PROFIBUS GSD configuration. However, if necessary you can set this parameter using data records 64 to 71 or data record 128, see "Parameter data record" appendix.

5.1 Parameters

Parameter	Value range	Default	Parameter reassignment during RUN	Effective range with configuration software, e.g. STEP 7 (TIA Portal)	
				GSD file PROFINET IO	GSD file PROFIBUS DP
Channel enabled	<ul style="list-style-type: none"> Disable Enable 	Enable	Yes	Channel	Channel
Reaction to CPU STOP	<ul style="list-style-type: none"> Turn off Keep last value Output substitute value 1 	Turn off	Yes	Channel	Module ¹
Potential group	<ul style="list-style-type: none"> Use the potential group of the left module (module plugged into a dark-colored BaseUnit) Enable new potential group (module plugged into a light-colored BaseUnit) 	Use potential group of the left module	No	Module	Module

¹ Due to the limited number of parameters at a maximum of 244 bytes per ET 200SP station with a PROFIBUS GSD configuration, the possible parameter settings are restricted. The parameter length of the I/O module is 8 bytes for PROFIBUS GSD configuration. However, if necessary you can set this parameter using data records 64 to 71 or data record 128, see "Parameter data record" appendix.

NOTE

- If both parameters "Diagnostics: Short-circuit to L+" and "Diagnostics: Wire break" are enabled and one of these diagnostic events occurs, the affected channel is switched off. This prevents undefined load switching and the corresponding diagnostics alarm is triggered.
- If the parameter "Diagnostics: Wire break" is enabled and "Diagnostics: Short-circuit to L+" is disabled and a "Diagnostics: Wire break" is present, the affected channel is switched off. This prevents undefined load switching and the corresponding diagnostics alarm is triggered.
- If the parameter "Diagnostics: Short-circuit to L+" is enabled and "Diagnostics: Wire break" is disabled, the signal state is retained at the affected channel when "Diagnostics: Short-circuit to L+" occurs. A diagnostics alarm is triggered only for 0 signal.

5.2 Explanation of parameters

Diagnostics: No supply voltage L+

Enabling of the diagnostics for no or insufficient supply voltage L+.

Diagnostics: Short-circuit to ground

Enabling of the diagnostics if a short-circuit of the actuator supply to ground occurs.

Diagnostics: Short-circuit to L+

Enabling of the diagnostics if a short-circuit of the actuator supply to L+ occurs.

Check for wire break

Specifies whether a check for wire break is carried out for the channel. Diagnostics: Wire break can only be reported if the check for wire break is enabled. If the check for wire break is disabled, the measuring current for the channel is also disabled.

Diagnostics: Wire break

Enabling of the diagnostics if the line to the actuator is broken. If Diagnostics: Wire break is enabled, the "Check for wire break" parameter must also be enabled for the channel.

Channel enabled

Determines whether a channel is enabled or disabled.

Reaction to CPU STOP

Determines the behavior of the module in the event of a CPU STOP.

Potential group

A potential group consists of a group of directly adjacent I/O modules within an ET 200SP station, which are supplied via a common supply voltage.

A potential group starts with a light-colored BaseUnit through which the required voltage is supplied for all modules of the potential group. The light-colored BaseUnit interrupts the three self-assembling voltage buses P1, P2 and AUX to the left neighbor.

Specify on which slot a light-colored BaseUnit with supply voltage feed or a dark-colored BaseUnit is located (see ET 200SP Distributed I/O System

(<https://support.industry.siemens.com/cs/ww/en/view/58649293>) System Manual).

All additional I/O modules of this potential group are plugged into dark-colored BaseUnits. You take the potential of the self-assembling voltage buses P1, P2 and AUX from the left neighbor.

The station setup must be completed with a server module.

5.3 Address space

The module can be configured differently in STEP 7; see the table below. Depending on the configuration, additional/different addresses are assigned in the process image output/input.

Configuration options of DQ 8x24VDC/0.5A HF

You can configure the module with STEP 7 (TIA Portal) or with a GSD file. If you configure the module by means of a GSD file, the configurations are available under various short designations/module names; see the table below. The following configurations are possible:

Table 5-2 Configuration options with GSD file

Configuration	Short designation/module name in the GSD file	Configuration software, e.g. with STEP 7 (TIA Portal)		
		Integrated in the STEP 7 hardware catalog from V19 with HSP0428	GSD file PROFINET IO	GSD file PROFIBUS DP
1 x 8-channel without value status	DQ 8x24VDC/0.5A HF V1.0	X	X	X
1 x 8-channel with value status	DQ 8x24VDC/0.5A HF V1.0, QI	X	X	X
1 x 8-channel with value status for module-internal Shared Output with up to 4 submodules	DQ 8x24VDC/0.5A HF V1.0, MSO	X	X	-
2 x 4-channel without value status	DQ 8x24VDC/0.5A HF V1.0, S.2	X	X	-
2 x 4-channel with value status	DQ 8x24VDC/0.5A HF V1.0, S.2 QI	X	X	-
4 x 2-channel without value status	DQ 8x24VDC/0.5A HF V1.0, S.4	X	X	-
4 x 2-channel with value status	DQ 8x24VDC/0.5A HF V1.0, S.4 QI	X	X	-

NOTE

The following functions are only fully available when the submodule X.1 is configured and the IO controller to which submodule X.1 is assigned has established a connection to the IO device.

- Firmware update
- I&M identification data
- PROFIenergy

2 x 4- / 4 x 2-channel configuration

For the configuration, the channels of the module are divided into multiple submodules. These submodules can be assigned to different IO controllers when the module is used in a Shared Device.

The number of usable submodules is dependent on the interface module used. Read the information in the manual for the particular interface module.

Value status (Quality Information, QI)

The value status is always activated for the following configurations:

- DQ 8x24VDC/0.5A HF V1.0, QI
- DQ 8x24VDC/0.5A HF V1.0, MSO
- DQ 8x24VDC/0.5A HF V1.0, S.2 QI
- DQ 8x24VDC/0.5A HF V1.0, S.4 QI

An additional bit is assigned to each channel for the value status. The bit for the value status indicates if the output value specified by the user program is actually pending at the module terminal (0 = value is incorrect).

You can find more information on evaluating the value status in the ET 200SP Distributed I/O System (<https://support.industry.siemens.com/cs/ww/en/view/58649293>) System Manual.

Address space for configuration as 1 x 8-channel DQ 8x24VDC/0.5A HF V1.0

The following figure shows the assignment of the address space for the configuration as 1 x 8-channel module without value status. "QB" stands for output byte.

Assignment in the process image of the outputs (PIQ)

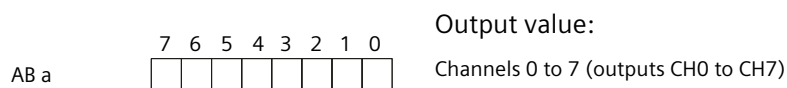
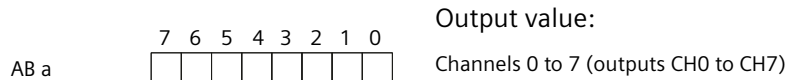

Figure 5-1 Address space for configuration as 1 x 8-channel DQ 8x24VDC/0.5A HF V1.0

Address space for configuration as 1 x 8-channel DQ 8x24VDC/0.5A HF V1.0, QI

The following figure shows the assignment of the address space for the configuration as 1 x 8-channel module with value status. You can freely assign the start address for the module. The addresses of the channels are derived from the start address. "IB" stands for input byte. "QB" stands for output byte.

Assignment in the process image outputs (PIQ)



Assignment in the process image inputs (PII)

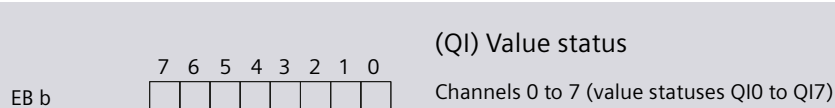

0 = Value output at channel is faulty

Figure 5-2 Address space for configuration as 1 x 8-channel DQ 8x24VDC/0.5A HF V1.0, QI

Address space for configuration as 1 x 8-channel DQ 8x24VDC/0.5A HF V1.0, MSO

For the configuration as a 1 x 8-channel module (module-internal Shared Output, MSO), channels 0 to 7 of the module are copied to up to four submodules. Channels 0 to 7 are then available with identical values in various submodules. These submodules can be assigned to up to four IO controllers when the module is used in a shared device:

- The IO controller to which submodule 1 is assigned has write access to outputs 0 to 7.
- The IO controllers to which submodule 2, 3, or 4 is assigned have read access to outputs 0 to 7.

Value status (Quality Information, QI)

The meaning of the value status depends on the submodule on which it occurs.

In the 1st submodule (= basic submodule), the value status 0 indicates that the value is incorrect or that the IO controller of the basic submodule is in STOP state.

For the 2nd to 4th submodule (= MSO submodule), the value status 0 indicates that the value is incorrect or one of the following errors has occurred:

- The basic submodule is not yet configured (not ready).
- The connection between the IO controller and the basic submodule has been interrupted.
- The IO controller of the basic submodule is in STOP or POWER OFF state.

5.3 Address space

The following figure shows the assignment of the address space for submodules 1, 2, 3, and 4 and the value status. "IB" stands for input byte. "QB" stands for output byte.

Assignment in the process image outputs (PIQ) for the 1st submodule

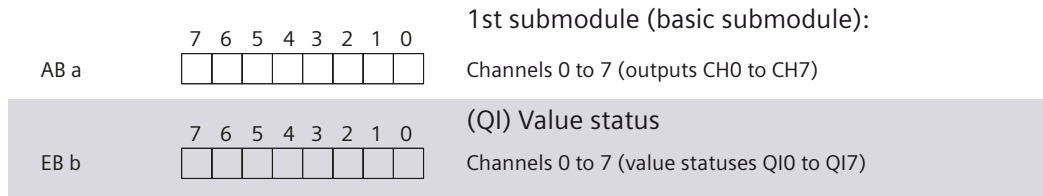

Assignment in the process image inputs (PII) for the 2nd submodule

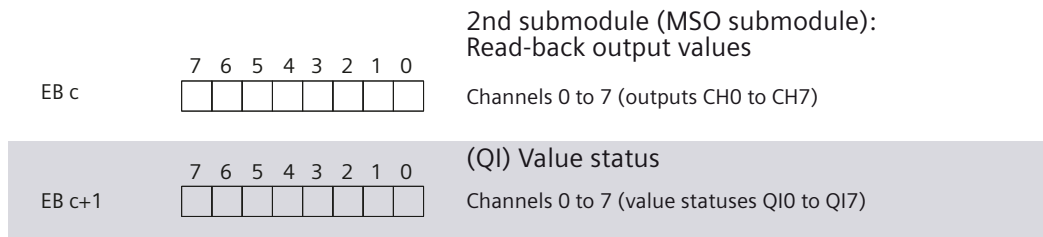

Assignment in the process image inputs (PII) for the 3rd submodule

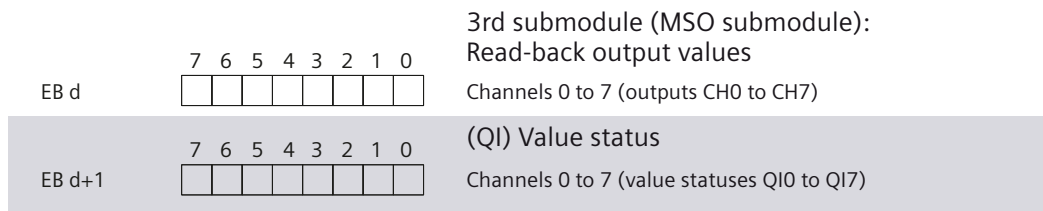

Assignment in the process image inputs (PII) for the 4th submodule

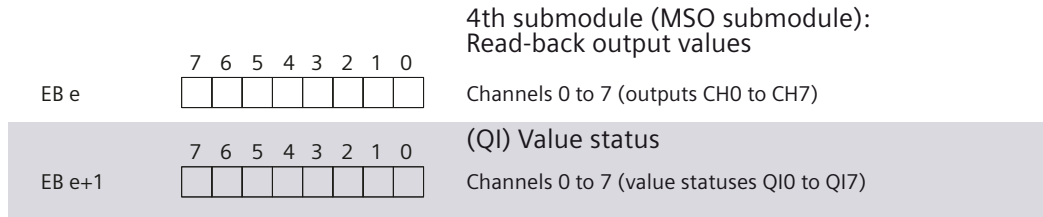

0 = Value output at channel is faulty

Figure 5-3 Address space for configuration as 1 x 8-channel DQ 8x24VDC/0.5A HF V1.0, MSO

Address space for configuration as 2 x 4-channel DQ 8x24VDC/0.5A HF V1.0, S.2

The figure below shows the address space assignment for configuration as a 2 x 4-channel module without value status.

Each of the two submodules has a freely assignable start address. "QB" stands for output byte.

Assignment in the process image outputs (PIQ)

										Output value:	
	7	6	5	4	3	2	1	0			
AB a	0	0	0	0					Channels 0 to 3 (outputs CH0 to CH3)	1st submodule	
	7	6	5	4	3	2	1	0			
AB b	0	0	0	0					Channels 4 to 7 (outputs CH4 to CH7)	2nd submodule	

Figure 5-4 Address space for configuration as 2 x 4-channel DQ 8x24VDC/0.5A HF V1.0, S.2

Address space for configuration as 2 x 4-channel DQ 8x24VDC/0.5A HF V1.0, S.2 QI

The figure below shows the address space assignment for configuration as a 2 x 4-channel module with value status.

Each of the two submodules has a freely assignable start address. "IB" stands for input byte. "QB" stands for output byte.

Assignment in the process image outputs (PIQ)

										Output value:	
	7	6	5	4	3	2	1	0			
AB a	0	0	0	0					Channels 0 to 3 (outputs CH0 to CH3)	1st submodule	
	7	6	5	4	3	2	1	0			
AB b	0	0	0	0					Channels 4 to 7 (outputs CH4 to CH7)	2nd submodule	

Assignment in the process image inputs (PII)

										(QI) Value status	
	7	6	5	4	3	2	1	0			
EB c	0	0	0	0					Channels 0 to 3 (value statuses QI0 to QI3)	1st submodule	
	7	6	5	4	3	2	1	0			
EB d	0	0	0	0					Channels 4 to 7 (value statuses QI4 to QI7)	2nd submodule	

0 = Value output at channel is faulty

Figure 5-5 Address space for configuration as 2 x 4-channel DQ 8x24VDC/0.5A HF V1.0, S.2 QI

Address space for configuration as 4 x 2-channel DQ 8x24VDC/0.5A HF V1.0, S.4

The following figure shows the assignment of the address space for the configuration as a 4 x 2-channel module without value status.

Each of the four submodules has a freely assignable start address. "QB" stands for output byte.

Assignment in the process image of the outputs (PIQ)

		Output value:																	
AB a	<table border="1" style="border-collapse: collapse; text-align: center;"> <tr> <td>7</td><td>6</td><td>5</td><td>4</td><td>3</td><td>2</td><td>1</td><td>0</td> </tr> <tr> <td>0</td><td>0</td><td>0</td><td>0</td><td>0</td><td>0</td><td></td><td></td> </tr> </table>	7	6	5	4	3	2	1	0	0	0	0	0	0	0			Channels 0 and 1 (outputs CH0 and CH1)	1st submodule
7	6	5	4	3	2	1	0												
0	0	0	0	0	0														
AB b	<table border="1" style="border-collapse: collapse; text-align: center;"> <tr> <td>7</td><td>6</td><td>5</td><td>4</td><td>3</td><td>2</td><td>1</td><td>0</td> </tr> <tr> <td>0</td><td>0</td><td>0</td><td>0</td><td>0</td><td>0</td><td></td><td></td> </tr> </table>	7	6	5	4	3	2	1	0	0	0	0	0	0	0			Channels 2 and 3 (outputs CH2 and CH3)	2nd submodule
7	6	5	4	3	2	1	0												
0	0	0	0	0	0														
AB c	<table border="1" style="border-collapse: collapse; text-align: center;"> <tr> <td>7</td><td>6</td><td>5</td><td>4</td><td>3</td><td>2</td><td>1</td><td>0</td> </tr> <tr> <td>0</td><td>0</td><td>0</td><td>0</td><td>0</td><td>0</td><td></td><td></td> </tr> </table>	7	6	5	4	3	2	1	0	0	0	0	0	0	0			Channels 4 and 5 (outputs CH4 and CH5)	3rd submodule
7	6	5	4	3	2	1	0												
0	0	0	0	0	0														
AB d	<table border="1" style="border-collapse: collapse; text-align: center;"> <tr> <td>7</td><td>6</td><td>5</td><td>4</td><td>3</td><td>2</td><td>1</td><td>0</td> </tr> <tr> <td>0</td><td>0</td><td>0</td><td>0</td><td>0</td><td>0</td><td></td><td></td> </tr> </table>	7	6	5	4	3	2	1	0	0	0	0	0	0	0			Channels 6 and 7 (outputs CH6 and CH7)	4th submodule
7	6	5	4	3	2	1	0												
0	0	0	0	0	0														

Figure 5-6 Address space for configuration as 4 x 2-channel DQ 8x24VDC/0.5A HF V1.0, S.4

Address space for configuration as 4 x 2-channel DQ 8x24VDC/0.5A HF V1.0, S.4 QI

The following figure shows the assignment of the address space for the configuration as a 4 x 2-channel module with value status.

Each of the four submodules has a freely assignable start address. "IB" stands for input byte. "QB" stands for output byte.

Assignment in the process image outputs (PIQ)

	7	6	5	4	3	2	1	0	Output value:	
AB a	0	0	0	0	0	0			Channels 0 and 1 (outputs CH0 and CH1)	1st submodule
AB b	0	0	0	0	0	0			Channels 2 and 3 (outputs CH2 and CH3)	2nd submodule
AB c	0	0	0	0	0	0			Channels 4 and 5 (outputs CH4 and CH5)	3rd submodule
AB d	0	0	0	0	0	0			Channels 6 and 7 (outputs CH6 and CH7)	4th submodule

Assignment in the process image inputs (PII)

	7	6	5	4	3	2	1	0	(QI) Value status	
EB e	0	0	0	0	0	0			Channels 0 and 1 (value statuses QI0 and QI1)	1st submodule
EB f	0	0	0	0	0	0			Channels 2 and 3 (value statuses QI2 and QI3)	2nd submodule
EB g	0	0	0	0	0	0			Channels 4 and 5 (value statuses QI4 and QI5)	3rd submodule
EB h	0	0	0	0	0	0			Channels 6 and 7 (value statuses QI6 and QI7)	4th submodule

0 = Value output at channel is faulty

Figure 5-7 Address space for configuration as 4 x 2-channel DQ 8x24VDC/0.5A HF V1.0, S.4 QI

Interrupts/diagnostics alarms

6.1 Status and error displays

LED displays

The figure below shows the LED displays (status and error displays) of the module:

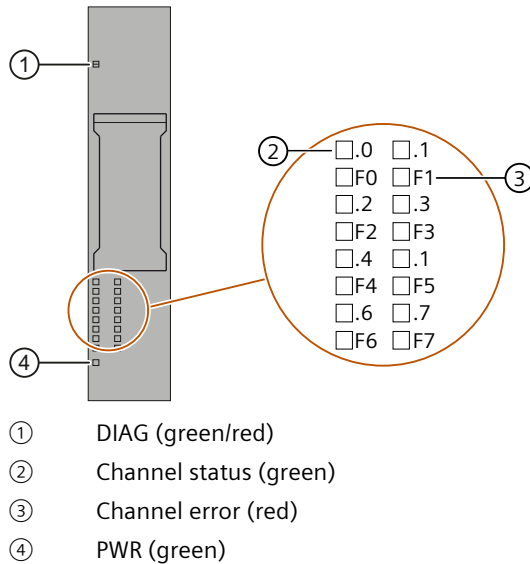

- ① DIAG (green/red)
- ② Channel status (green)
- ③ Channel error (red)
- ④ PWR (green)

Figure 6-1 LED displays

Meaning of the LEDs

The following tables explain the meaning of the status and error displays. Corrective measures for diagnostics alarms can be found in section [Diagnostics alarms \(Page 34\)](#).

DIAG LED

Table 6-1 Error display of the DIAG LED

DIAG LED	Meaning
<div style="text-align: center;">□ Off</div>	The system's backplane bus supply is faulty or switched off
<div style="text-align: center;">⚡ Flashes</div>	Module parameters not assigned
<div style="text-align: center;">■ On</div>	Module parameters assigned and no module/channel diagnosis data available
<div style="text-align: center;">⚡ Flashes</div>	Module parameters assigned with module/channel diagnosis data available

Channel status and channel diagnosis LEDs

Table 6-2 Status display of the channel status/channel error LED

Channel status LED	Channel error LED	Meaning
□ Off	□ Off	Channel disabled or enabled and process signal = 0 and no channel diagnosis data available
■ On	□ Off	Channel enabled and process signal = 1 and no channel diagnosis data available
□ Off	■ On	Channel enabled and channel diagnosis data available

PWR LED

Table 6-3 Status display of the PWR LED

PWR LED	Meaning
□ Off	No supply voltage L+
■ On	Supply voltage L+ present

6.2 Interrupts

The DQ 8x24VDC/0.5A HF digital output module supports diagnostic interrupts.

Diagnostic interrupts

The module generates a diagnostic interrupt at the following events:

- Short-circuit
- Wire break
- Parameter assignment error
- Supply voltage missing
- Channel/component temporarily unavailable

Detailed information on the event is available in the STEP 7 online help.

6.3 Diagnostics alarms

A diagnostic message is generated and the DIAG-LED flashes red on the module for each diagnostics event. You can read out the diagnostic messages, for example, in the diagnostic buffer of the CPU. You can evaluate the error codes with the user program.

NOTE

Wiring 2 outputs in parallel

When connecting 2 outputs in parallel for redundant control of a load, the channel diagnoses "Short-circuit to L+" and "Wire break" must be disabled, otherwise erroneous diagnostic messages may occur.

Table 6-4 Diagnostic messages, their meaning, and remedial measures

Diagnostic message	Error code	Meaning	Solution
Short-circuit	1 _H	<ul style="list-style-type: none"> Short-circuit of actuator supply to ground ¹ Short-circuit of actuator supply to L+ ² 	Correct the process wiring
Wire break	6 _H	Actuator circuit impedance too high	Use a different actuator type or modify the wiring, e.g. use cables with a larger cross-section
		Wire break between the module and actuator	Connect the cable
		Channel not connected (open)	<ul style="list-style-type: none"> Disable diagnostics Connect a resistor to the actuator contacts in the load resistance range
Parameter assignment error	10 _H	<ul style="list-style-type: none"> Module cannot evaluate parameters for this channel Incorrect parameter assignment 	Correct the parameter assignment
No supply voltage	11 _H	No or insufficient supply voltage L+	<ul style="list-style-type: none"> Check the supply voltage L+ at the BaseUnit Check BaseUnit type
Channel/component temporarily unavailable	1F _H	Firmware update is currently in progress or has been canceled. The module does not output any process or substitute values in this state.	<ul style="list-style-type: none"> Wait for firmware update Restart the firmware update

¹ Only in switched state (output value 1)

² Only in non-switched state (output value 0)

NOTE

In case of a short-circuit of the actuator supply to L+ at the activated channel, load distributions can occur which result in wire break diagnoses.

Technical specifications

7.1 Technical specifications

Technical specifications of the DQ 8x24VDC/0.5A HF

The following table lists the technical specifications as of the issue date. You can find a data sheet including the latest technical specifications on the Internet

(<https://support.industry.siemens.com/cs/ww/en/pv/6ES7132-6BF01-0CA0/td?dl=de>).

Article number	6ES7132-6BF01-0CA0
General information	
Product type designation	DQ 8x24VDC/0.5A HF
HW functional status	01
Firmware version	V1.0
<ul style="list-style-type: none"> FW update possible 	Yes
usable BaseUnits	BU type A0
Color code for module-specific color identification plate	CC02
Product function	
<ul style="list-style-type: none"> I&M data 	Yes; I&M0 to I&M3
<ul style="list-style-type: none"> Isochronous mode 	Yes
Engineering with	
<ul style="list-style-type: none"> STEP 7 TIA Portal configurable/integrated from version 	as of TIA Portal V19 with HSP0428 / integrated as of TIA Portal V20
<ul style="list-style-type: none"> STEP 7 configurable/integrated from version 	as of STEP 7 V5.5 SP3 with HSP0230 V11.0 / integrated as of STEP 7 V5.7 SP3
<ul style="list-style-type: none"> PROFIBUS from GSD version/GSD revision 	One GSD file each, Revision 3 and 5 and higher
<ul style="list-style-type: none"> PROFINET from GSD version/GSD revision 	GSDML V2.43
Operating mode	
<ul style="list-style-type: none"> DQ 	Yes
<ul style="list-style-type: none"> DQ with energy-saving function 	No
<ul style="list-style-type: none"> PWM 	No
<ul style="list-style-type: none"> Oversampling 	No
<ul style="list-style-type: none"> MSO 	Yes
Supply voltage	
Rated value (DC)	24 V
permissible range, lower limit (DC)	19.2 V
permissible range, upper limit (DC)	28.8 V
Reverse polarity protection	Yes

7.1 Technical specifications

Article number	6ES7132-6BF01-0CA0
Input current	
Current consumption, max.	20 mA; without load
output voltage / header	
Rated value (DC)	24 V
Power loss	
Power loss, typ.	1 W
Address area	
Address space per module	
<ul style="list-style-type: none"> Address space per module, max. 	8 byte; 2 channels per submodule + QI information
Hardware configuration	
Automatic encoding	Yes
<ul style="list-style-type: none"> Mechanical coding element 	Yes
<ul style="list-style-type: none"> Type of mechanical coding element 	Type A
Submodules	
<ul style="list-style-type: none"> Number of configurable submodules, max. 	4
Selection of BaseUnit for connection variants	
<ul style="list-style-type: none"> 1-wire connection 	BU type A0
<ul style="list-style-type: none"> 2-wire connection 	BU type A0
<ul style="list-style-type: none"> 3-wire connection 	BU type A0 with AUX terminals or potential distributor module
Digital outputs	
Type of digital output	Source output (PNP, current-sourcing)
Number of digital outputs	8
Current-sinking	No
Current-sourcing	Yes
Digital outputs, parameterizable	Yes
output characteristic acc. to IEC 61131, type 0.5	Yes
Short-circuit protection	Yes; Electronic
<ul style="list-style-type: none"> Response threshold, typ. 	0.7 to 1.3 A
Open-circuit detection	Yes
Limitation of inductive shutdown voltage to	Typ. L+ (-50 V)
Controlling a digital input	Yes
Switching capacity of the outputs	
<ul style="list-style-type: none"> with resistive load, max. 	0.5 A
<ul style="list-style-type: none"> with inductive load, max. 	0.5 A
<ul style="list-style-type: none"> on lamp load, max. 	5 W
Load resistance range	
<ul style="list-style-type: none"> lower limit 	48 Ω
<ul style="list-style-type: none"> upper limit 	12 kΩ

Article number	6ES7132-6BF01-0CA0
Output current	
<ul style="list-style-type: none"> for signal "1" rated value for signal "1" permissible range, max. for signal "0" residual current, max. 	<p>0.5 A</p> <p>0.5 A</p> <p>0.1 mA</p>
Output delay with resistive load	
<ul style="list-style-type: none"> "0" to "1", typ. "1" to "0", typ. 	<p>50 µs</p> <p>100 µs</p>
Parallel switching of two outputs	
<ul style="list-style-type: none"> for uprating for redundant control of a load 	<p>No</p> <p>Yes</p>
Switching frequency	
<ul style="list-style-type: none"> with resistive load, max. with inductive load, max. on lamp load, max. 	<p>100 Hz</p> <p>0.1 Hz; higher frequencies are possible, see Equipment Manual "Maximum permitted switching frequency of inductive loads"</p> <p>10 Hz</p>
Total current of the outputs	
<ul style="list-style-type: none"> Current per channel, max. Current per module, max. 	<p>0.5 A</p> <p>4 A</p>
Total current of the outputs (per module)	
horizontal installation	
– up to 60 °C, max.	4 A
vertical installation	
– up to 50 °C, max.	4 A
Cable length	
<ul style="list-style-type: none"> shielded, max. unshielded, max. 	<p>1 000 m</p> <p>600 m</p>
Isochronous mode	
Execution and activation time (TCO), min.	48 µs
Bus cycle time (TDP), min.	500 µs
Jitter, max.	8 µs
Interrupts/diagnostics/status information	
Diagnostics function	Yes
Substitute values connectable	Yes
Alarms	
<ul style="list-style-type: none"> Diagnostic alarm 	Yes
Diagnoses	
<ul style="list-style-type: none"> Monitoring the supply voltage – parameterizable 	<p>Yes</p> <p>Yes</p>

7.1 Technical specifications

Article number	6ES7132-6BF01-0CA0
<ul style="list-style-type: none"> • Wire-break • Short-circuit to M • Short-circuit to L+ • Group error 	<p>Yes; channel by channel</p> <p>Yes; channel by channel</p> <p>Yes; channel by channel</p> <p>Yes</p>
Diagnostics indication LED	
<ul style="list-style-type: none"> • Monitoring of the supply voltage (PWR-LED) • Channel status display • for channel diagnostics • for module diagnostics 	<p>Yes; green PWR LED</p> <p>Yes; green LED</p> <p>Yes; red LED</p> <p>Yes; green/red DIAG LED</p>
Potential separation	
Potential separation channels	
<ul style="list-style-type: none"> • between the channels • between the channels and backplane bus • Between the channels and load voltage L+ 	<p>No</p> <p>Yes</p> <p>No</p>
Isolation	
Isolation tested with	707 V DC (type test)
Standards, approvals, certificates	
Suitable for safety functions	No
Suitable for safety-related tripping of standard modules	No
Ambient conditions	
Ambient temperature during operation	
<ul style="list-style-type: none"> • horizontal installation, min. • horizontal installation, max. • vertical installation, min. • vertical installation, max. 	<p>-30 °C</p> <p>60 °C</p> <p>-30 °C</p> <p>50 °C</p>
Altitude during operation relating to sea level	
<ul style="list-style-type: none"> • Installation altitude above sea level, max. 	5 000 m; restrictions for installation altitudes > 2 000 m, see ET 200SP system manual
Dimensions	
Width	15 mm
Height	73 mm
Depth	58 mm
Weights	
Weight, approx.	30 g

Residual current for signal state "0"

NOTE

Residual current for signal state "0"

Due to the Diagnostics: Wire break function, a small residual current flows in signal state "0" of the output when the check for wire break is enabled. This may cause the display diodes to flicker.

You can minimize this residual current with the "Check for wire break" parameter.

Maximum permitted switching frequency of inductive loads

The following trends show the maximum permissible switching frequency of inductive loads as a function of inductance and channel current. The maximum switching frequency applies to a pulse-pause ratio of 50%. The channel contributes 500 mA to the total current of the module, even if the actual channel current is smaller.

If you do not know the inductance of the actuator, assume a maximum inductance of 1.152 H for DC-13 loads (IEC 60947-5-1).

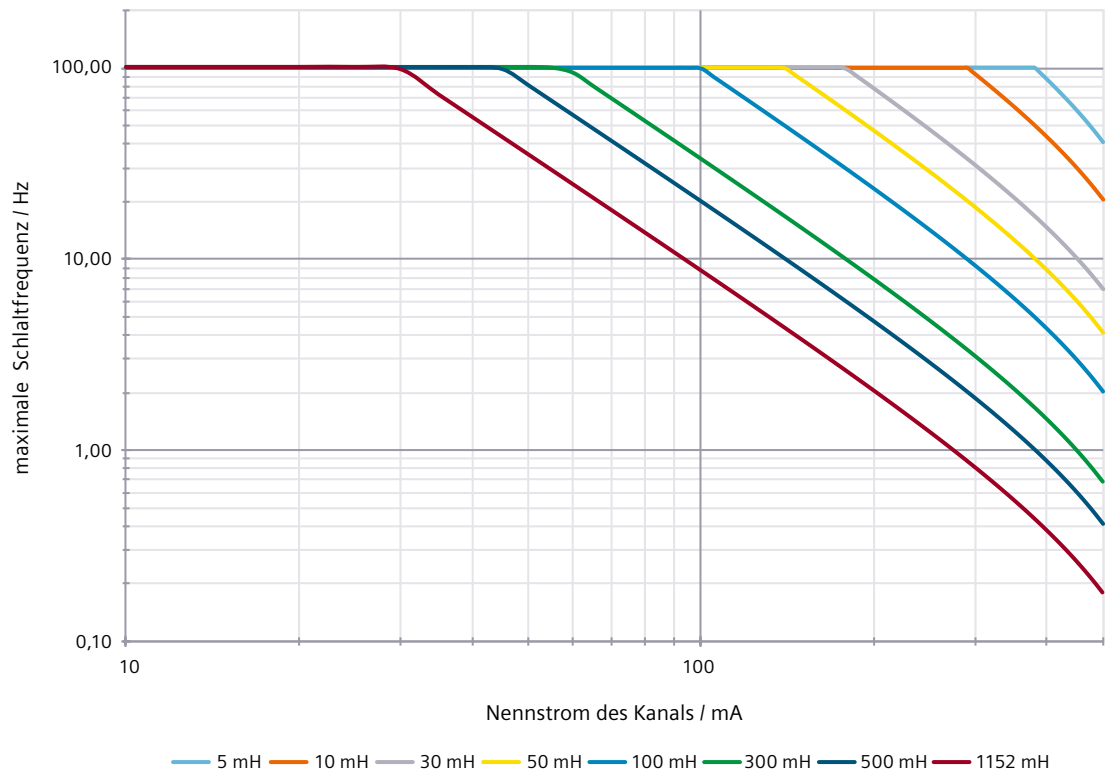

Figure 7-1 Maximum switching frequency

Dimension drawing

See manual ET 200SP BaseUnits

<https://support.industry.siemens.com/cs/ww/en/view/59753521>

Parameter data record

A.1 Parameter assignment and structure of parameter data record

The data record of the module has an identical structure, regardless of whether you configure the module with PROFIBUS DP or PROFINET IO. With data record 128, you can reassign the module parameters in your user program, regardless of your programming. This means that you can use all the functions of the module even if you configured it via PROFIBUS-GSD. With data records 64 to 71, you can configure individual channels.

Parameter assignment in the user program

You have the option to reassign the module parameters in RUN (e.g. the response of selected channels to the CPU-STOP state can be changed in RUN without having an effect on the other channels).

Reassigning parameters in RUN

The WRREC instruction is used to transfer the parameters to the module using data record 128 or data records 64 to 71. The parameters set in STEP 7 are not changed in the CPU, which means that the parameters set in STEP 7 will be valid again after a restart.

If you reconfigure a module and diagnostics are pending prior to the reconfiguration, these diagnostics are not signaled as "outgoing".

Output parameter STATUS

The module ignores errors that occur during the transfer of parameters with the "WRREC" instruction and continues operation with the previous parameter assignment. However, the STATUS output parameter contains a corresponding error code.

You will find a description of the "WRREC" instruction and the error codes in the STEP 7 online help.

Data record structure

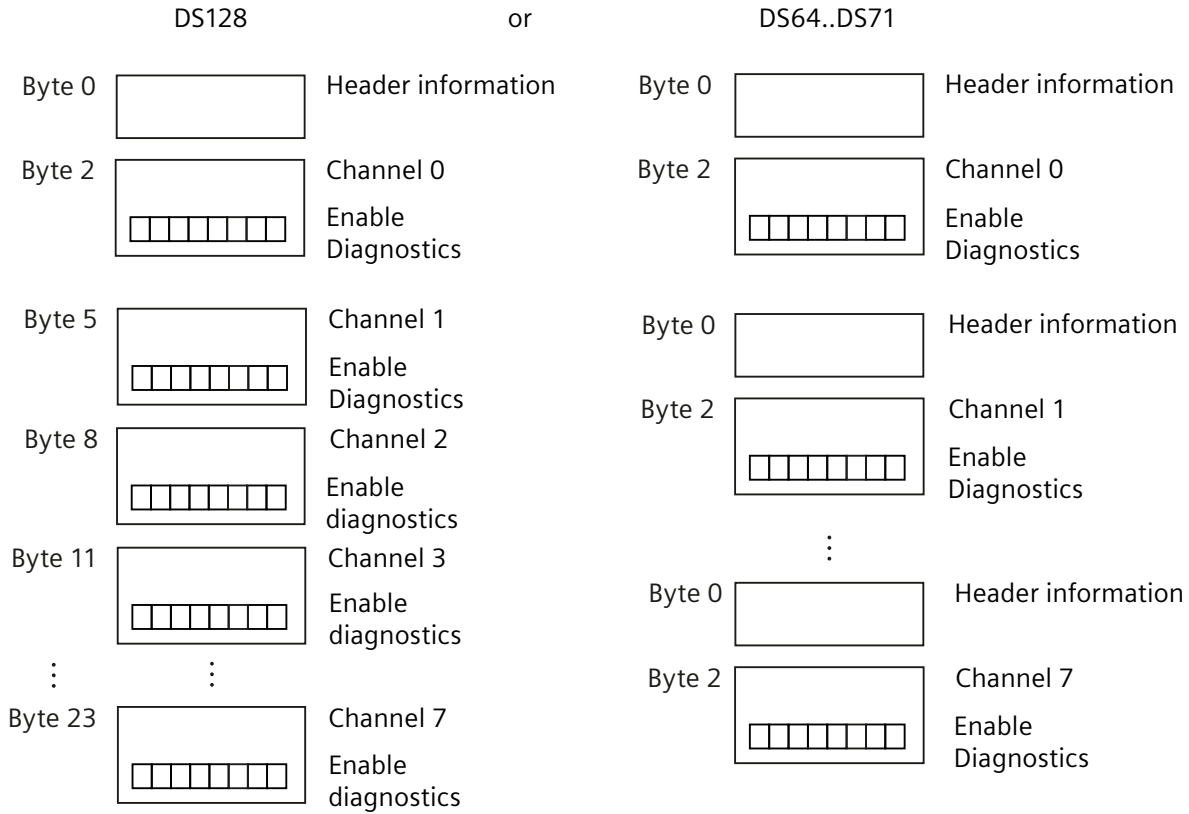

Figure A-1 Structure of data record 128 and data record 64 to 71

Header information

The figure below shows the structure of the header information.

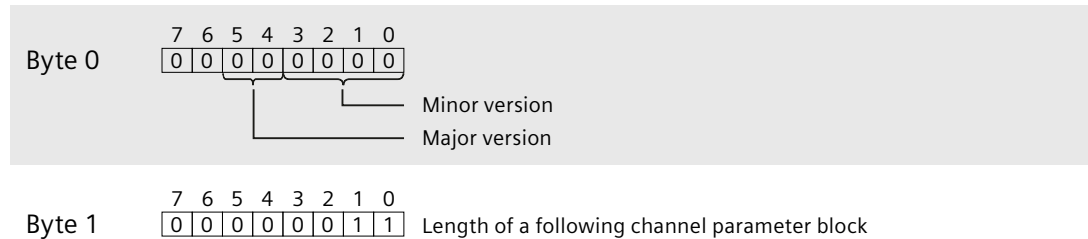
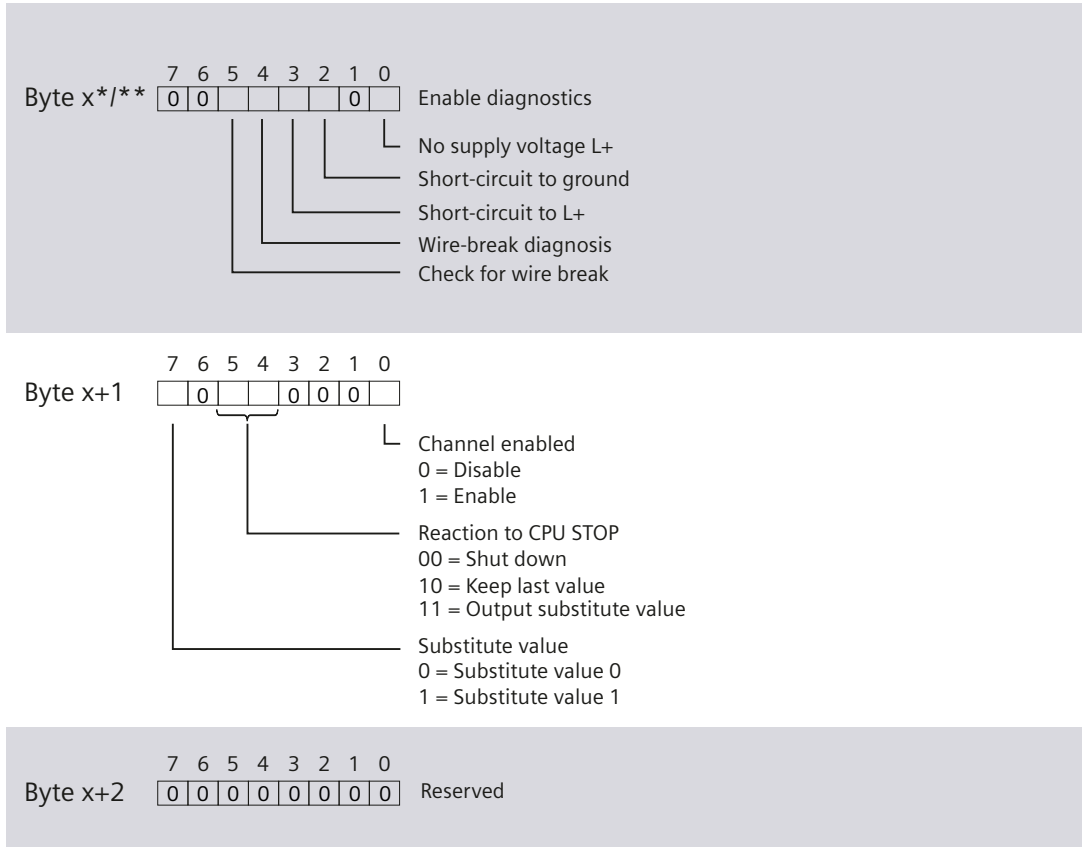

Figure A-2 Header information

Parameters

The figure below shows the structure of the parameters for channels 0 to 7. You can enable a parameter by setting the corresponding bit to "1".



* x = 2 + (channel number × 3); Channel number = 0 to 7 for DS 128
 ** x = 2 for DS 64 to DS 71

Figure A-3 Structure of byte x to x+2 for channels 0 to 7

A.2 Error codes

Error transmitting the data record

The module always checks all the values of the transferred data record. The module applies the values from the data record only when all values have been transmitted without errors.

The WRREC instruction for writing data records returns the appropriate error code if there are errors in the STATUS parameter.

The following table shows the module-specific error codes and their meaning for parameter data record 128.

Table A-1 Error messages, their meaning, and remedial measures

Error code in STATUS parameter (hexadecimal)				Meaning	Solution
Byte 0	Byte 1	Byte 2	Byte 3		
DF _H	80 _H	B0 _H	00 _H	Number of the data record unknown	Enter a valid number for the data record.
DF _H	80 _H	B1 _H	01 _H	Length of the data record incorrect	Enter a valid value for the data record length.
DF _H	80 _H	B2 _H	00 _H	Module not accessible	<ul style="list-style-type: none"> • Check station. • Plug the module in correctly. • Check parameters of the WRREC block.
DF _H	80 _H	E0 _H	01 _H	Header error (version or specified bits incorrect)	Correct version number or specified bits, see Header information (Page 40).
DF _H	80 _H	E0 _H	02 _H	Header error (number or length of parameter structures or parameter blocks incorrect)	Correct the number and length of the parameter structures or parameter blocks, see Header information (Page 40).
DF _H	80 _H	E1 _H	01 _H	Reserved bit set	Write 0 to all reserved bits.
DF _H	80 _H	E1 _H	02 _H	Invalid diagnostics enable bit set for operating mode	Correct diagnostics enables. For dependence on "Check for wire break" parameter, see Structure Byte x to x+2 for channels 0 to 7 (Page 40)
DF _H	80 _H	E1 _H	06 _H	Invalid coding for substitute value behavior	Use valid coding for "Reaction to CPU STOP" parameter, see Structure of byte x to x+2 for channels 0 to 7 (Page 40).