

ULINE

RATCHET TIE-DOWNS

1-800-295-5510
uline.com

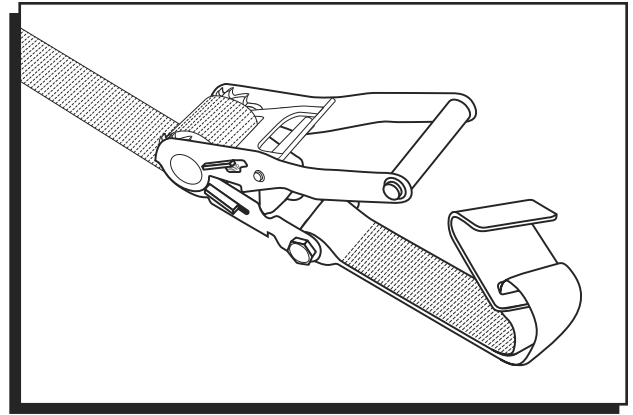

USAGE INSTRUCTIONS

1. Fully engage end hooks so that a secure tie down point rests against the base (Bearing Point) of the hook. Never load tip of hook.

 **NOTE:** Handle must always be in line with direction of pull to achieve Working Load Limit. (See Figure 1)

2. Insert free end of strap through mandrel slot in ratchet and pull through until strap is snug around the load. (See Figure 2)
3. If handle is closed and locked, pull on the Lock Release Handle to disengage. (See Figure 3) Then tighten strap by pumping the handle until strap is tight. (See Figure 4)

 **NOTE:** A minimum of two wraps of webbing around the mandrel is required.

4. Lock ratchet assembly by pulling on Lock Release Handle and pushing main handle until fully closed.
5. To release tension or remove tiedown, pull on Lock Release Handle and rotate main handle 180° to lock in the open position. Mandrel will be free to turn and release webbing. (See Figure 5)

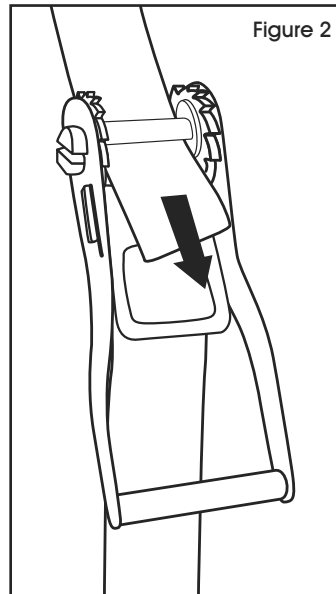

Figure 2

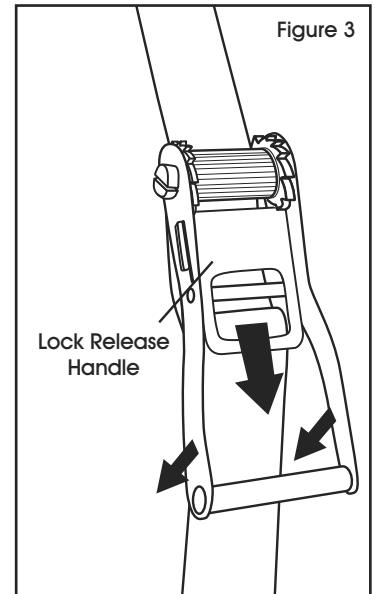

Figure 3

Lock Release Handle

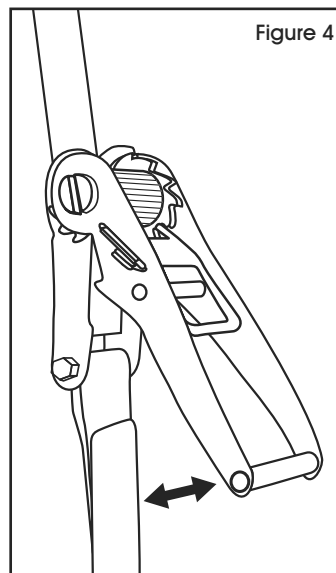

Figure 4

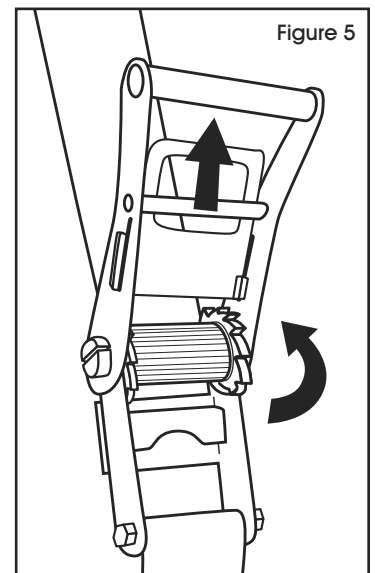

Figure 5

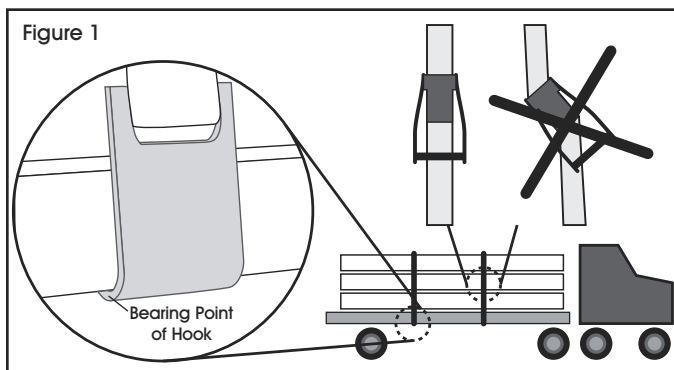
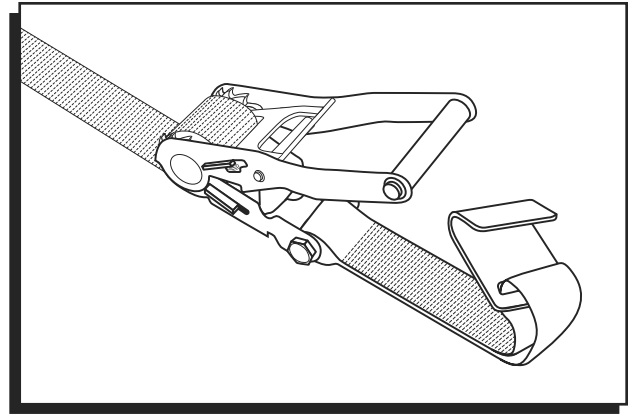



Figure 1

Bearing Point
of Hook

**INSTRUCCIONES DE USO**

1. Enganche completamente los extremos para que la correa quede apoyada contra la base (Punto de Suspensión) del gancho. Nunca cargue la punta del gancho.

 **NOTA:** La palanca siempre debe estar en línea con la dirección en la que va a jalar la correa para llegar al Límite de Carga de Trabajo. (Vea Diagrama 1)

2. Inserte el extremo suelto de la correa por la ranura del mandril en el trinquete y jale hasta que la correa quede bien ajustada a la carga. (Vea Diagrama 2)
3. Si la palanca está cerrada y asegurada, jale la Palanca de Liberación para abrirla. (Vea Diagrama 3) Luego ajuste la correa bombeando la palanca hasta que la correa quede tirante. (Vea Diagrama 4)

 **NOTA:** Se requieren mínimo dos vueltas de la correa por el mandril.

4. Cierre el ensamble del trinquete jalando la Palanca de Liberación y empujando la palanca principal hasta que quede completamente cerrado.
5. Para liberar tensión o quitar la correa, jale la Palanca de Liberación y gire la palanca principal 180° para quedar en la posición abierta. El mandril quedará libre para girar y remover la correa. (Vea Diagrama 5)

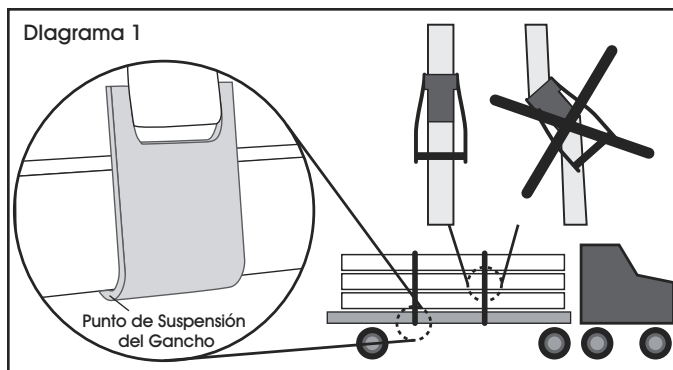
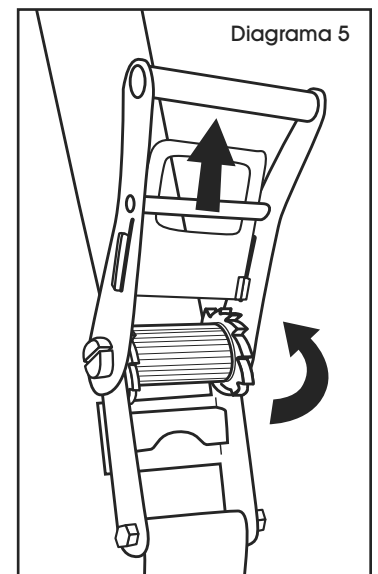
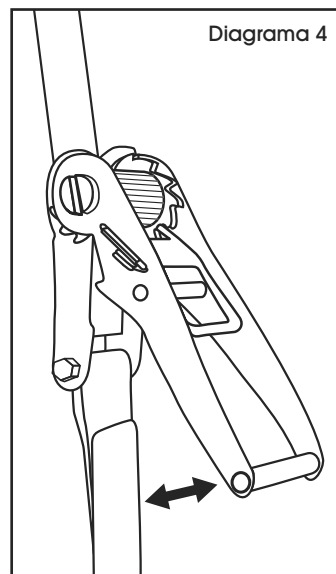
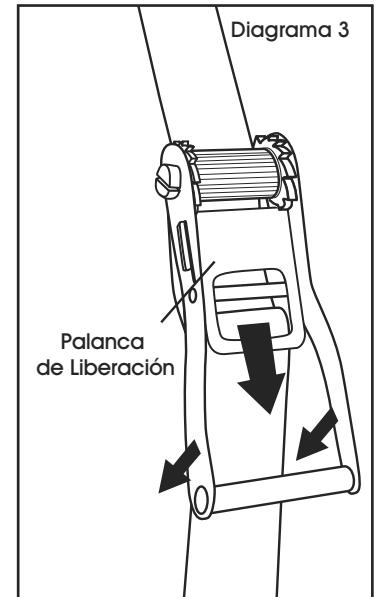
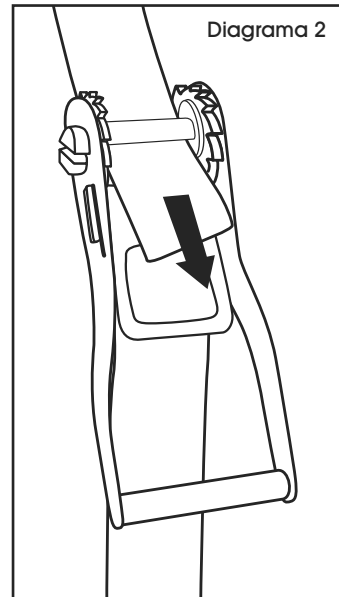

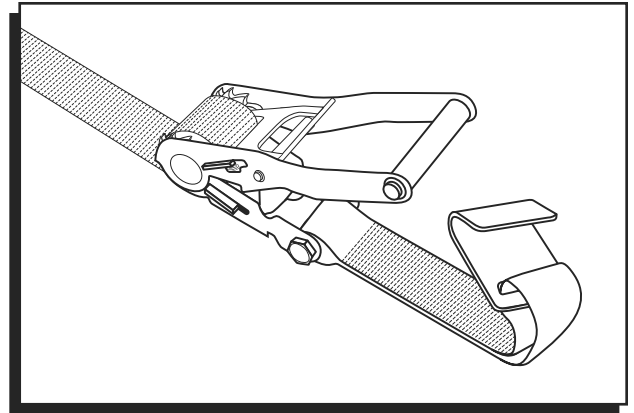
**DIRECTIVES D'UTILISATION**

1. Bien engager l'extrémité des crochets afin que le point d'ancrage repose contre la base (point d'appui) du crochet. Ne jamais charger le bout du crochet.

 **REMARQUE :** La poignée doit toujours être alignée dans le sens de la traction afin d'obtenir une limite de chargement fonctionnelle. (Voir figure 1)

2. Insérez l'extrémité libre de la sangle dans la fente du mandrin en cliquet et tirez jusqu'à ce que la sangle soit bien serrée autour du chargement. (Voir figure 2)
3. Si la poignée est fermée et bloquée, tirez sur la poignée de dégageur pour libérer. (Voir figure 3) Puis, serrez la sangle en pompant la poignée jusqu'à ce que la sangle soit serrée. (Voir figure 4)

 **REMARQUE :** Au moins deux tours de toile autour du mandrin sont nécessaires.

4. Bloquez le cliquet en tirant sur la poignée de dégageur et en poussant la poignée principale jusqu'à ce qu'elle soit complètement bloquée.

5. Pour libérer la tension ou retirer l'arrimage, tirez sur la poignée de dégageur et tournez la poignée principale à 180° pour bloquer en position ouverte. Le mandrin tournera librement et libérera la toile. (Voir figure 5)

