

The controller  
operates at a frequency  
of 868 MHz

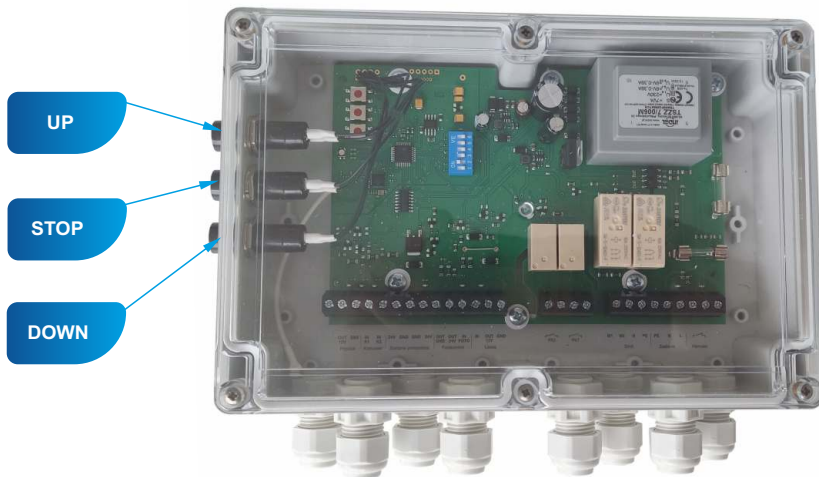

## Technical data :

<b>Power supply:</b>	230V 50Hz
<b>Transmission power:</b>	<25 mW
<b>Maximum motor power:</b>	900W



*A wired tubular motor can be connected to the SBR-BIDI gate controller if, before it is connected to the controller, the motor has had the limit positions set up.*



## SAFETY REQUIREMENTS



### 1. General rules

Before any installation or maintenance works, disconnect the gate controller from the power supply. Any installation or maintenance works shall be exclusively made by licensed personnel.

### 2. Installation warnings

The device shall be installed in a location inaccessible to children.  
Avoid installation in places exposed to direct impact of water, fire or intense sunlight.  
Signal and power supply wires shall be routed separately and protected against mechanical damage.

### 3. Use

Do not attempt to open the controller housing. Doing so may cause electric shock or damage to the device.

Do not operate the gate controller system if there are people, vehicles, or animals within its operating area.

In case of any unusual operation (e.g. no reaction to remote control, strange sounds), immediately disconnect the power supply and contact the maintenance technician or installer.

### 4. Maintenance and inspections

Regularly inspect wires, protective components, and mechanical fastenings.

Have your device inspected at least once a year by a licensed installer.

Do not use any chemical agents or water under pressure to clean the controller unit.

### 5. In case of a failure

In case of smoke, burning smell, or short circuit, immediately disconnect the power supply. Do not attempt to repair the device yourself.

Contact the maintenance technician, the installer or the manufacturer.

SBR – BIDI gate controller is intended to control the motor installed in the gate or roller shutter. Before you start operating the device, read this operating manual.

The gate controller controls such safety protection systems as:

- Resistive/optical safety edge - obstacle detection
- photocell - collision protection
- reed switches - information on gate position
- inertia brake - protection against rapid curtain falling
- warning light - gate movement signalling

Additionally, zone indicator light can be connected to the gate area lighting.

**NOTE: The gate controller operates correctly only when the safety devices indicate “no error.” Therefore, it is necessary to correctly set up the DIP electrical switches on the controller board (see: the connection diagram).**

**NOTE: The inertia brake and the (resistive/optical) safety edge are the absolutely required components. If they are not connected, the gate controller will not be able to control the motor that is connected to it.**

SBR – BIDI gate controller operates using two-way radio communication at a frequency of 868 MHz. Taking that into account, the system is controlled:

- via buttons on the gate controller,
- via Exalus Home remote controls,
- via Exta Life system transmitters,
- via the Exalus Home application, after the gate controller has been paired with the TR7 central unit (it is necessary to connect the autotest photocells).
- and via the monostable wall-mounted switch

Key fobs control devices in a sequence: up-down-down-up.

The Exalus Home application provides the user with a wider range of control functions for the gate controller:

- gate control: opening, closing, stopping, position adjustment (percentage),
- option to set automatic opening/closing,
- gate status view - errors, current position,
- activation of additional protections.

**NOTE: It is necessary to calibrate the gate controller when it is operated for the first time (see: 2. Calibration of the central control unit).**

When the calibration is successfully completed, two LEDs will illuminate: the main LED and the D4 LED.

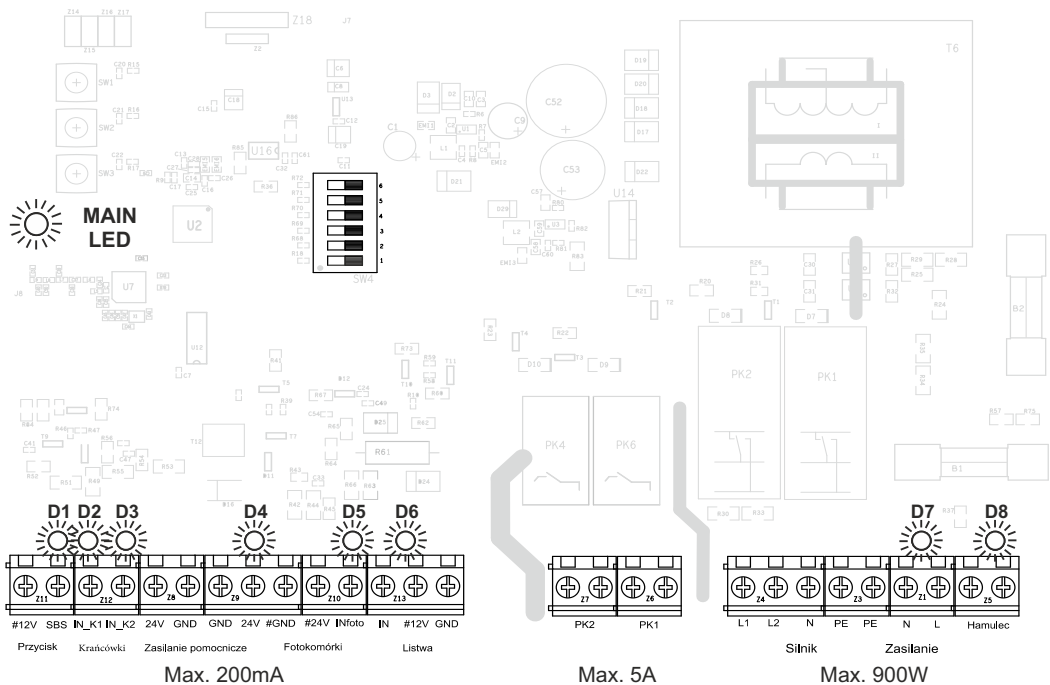

### OPTION 1

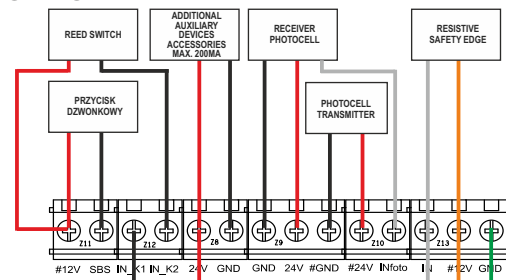

### OPTION 2

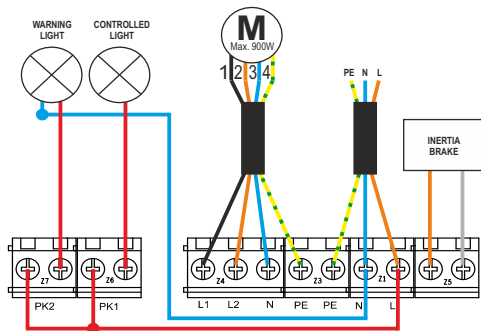

- 1 - L1 - direction 1
- 2 - L2 - direction 2
- 3 - N - neutral wire
- 4 - PE - (Protective Earth) wire

- D1 - button-level control
- D2 - reed switch (IN-K1)
- D3 - reed switch (IN-K2)
- D4 - 24 V power supply (permanent light)
- D5 - photocell status
- D6 - resistive safety edge status
- D7 - inertia brake status

### DIP electrical switches

- 1: ON – Optical safety edge
- 2: ON – Normally Open (NO) photocell (or no photocell installed);
- 3: ON – The self-test function of the photocell is enabled
- 4: ON – Automatic gate closing after default 60 seconds as of the gate opening (photocell required) The photocell 1 interruption resets the timer; if the gate was closing, it will reopen.

- OFF – Resistive safety edge 8,2kΩ
- OFF – Normally Closed (NC) photocell.
- OFF – The self-test function of the photocell is disabled
- OFF – Automatic gate closing disabled

**NOTE:** Any changes to the DIP electrical switches are read only after the gate controller's central unit has been connected to the power supply. After changing the settings, the central unit must be reconnected to read the updated data.

## 1. THE FIRST LAUNCH:

*NOTE: After switching on, the control operations can only be performed using the central unit buttons. The motor moves only if the button is pressed (no back-up). If the main LED blinks red and blue, the device is not calibrated.*

1. Make sure the central control unit is powered.
2. Check correctness of the movement directions using the central unit buttons.
3. In the case of inverted control outputs (directions), press and hold the STOP button for 3 seconds.

*NOTE: Correct setup of directions is required for proper operation of the safety edge (see: 6. Gate controller response to protections*

).

## 2. CALIBRATION OF THE CENTRAL CONTROL UNIT:

*NOTE: The device can only be calibrated if the safety devices indicate "no error." If the error warning is disregarded, calibration will be interrupted and the main LED will blink green, yellow and red several times, next it will blink blue and red again to indicate that the device has failed to be calibrated.*

1. Press and hold the UP and DOWN buttons on the controller simultaneously until the main LED blinks blue three times. The main LED starts glowing blue, signalling the first stage of calibration.
2. Press and hold the UP button, set the gate in its upper limit position and keep holding the button until the main LED has blinked blue 3 times. Next, the LED will start glowing yellow. If it glows green, move to point 4 of the calibration.

*NOTE: If, after the gate upper limit position has been set up, the LED fails to blink, this means that calibration has been interrupted or that the motor has not reached the limit position. Move to point 1 of the calibration.*

3. Press and hold the DOWN button, set the gate in its bottom limit position and keep holding the button until the main LED has blinked yellow 3 times. If it glows blue, move to point 2 of the calibration.
4. Calibration completed. The main LED is glowing with permanent green light.

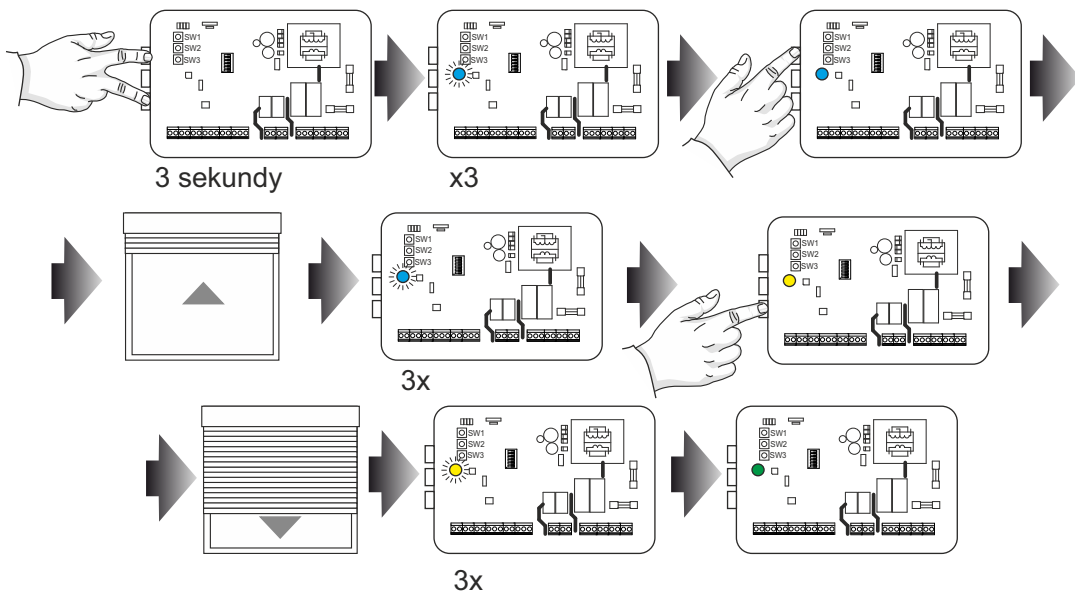

### 3. PAIRING THE TRANSMITTER:

*NOTE: The gate controller must be calibrated before you can start the pairing procedure. (see point 2 of CALIBRATION OF THE CENTRAL CONTROL UNIT).*

1. Press and hold the STOP button (for about 5 seconds) until the main LED starts glowing yellow (you can move to the pairing of devices).
2. Depending on the device to be paired:
  - on a sequential transmitter (e.g. key fob) - press the button that will be controlling the gate,
  - on the three-button (roller shutter) remote control - press the STOP button,
3. After the device is paired, the main LED blinks yellow 3 times.
4. The transmitter has been paired. The LED is glowing with permanent green light.

*NOTE: 5 minutes after the device pairing procedure has been activated, the gate controller returns to its normal mode of operation if no transmitter has been paired.*

*NOTE: Performing this procedure on an already programmed transmitter will cause it to be erased. The main LED will blink red 3 times.*

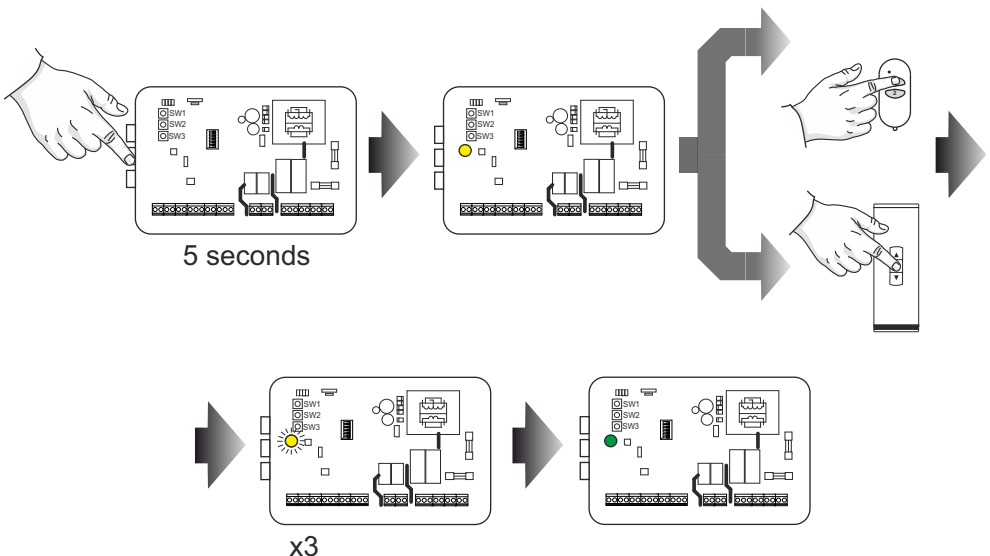

### 4. ADDING/REMOVING THE GATE CONTROLLER TO/FROM THE TR7 CENTRAL UNIT:

*NOTE: The gate controller must be calibrated before you can start this procedure (see point 2 of CALIBRATION OF THE CENTRAL CONTROL UNIT).*

*NOTE: To control the SBR-BIDI controller from the application level, it is necessary to connect the autotest photocells. Check if the DIP electrical switch no. 3 is turned on (ON).*

#### Adding a gate controller to the TR7 central unit

1. Press and hold the STOP button (for about 5 seconds) until the main LED starts glowing yellow (you can move to the pairing of devices).
2. Open the Exalus Home application.
3. Move to the "Channels" tab.
4. Press the "+" button in the right upper corner.

5. Press the “Search” button.
6. The “Gate controller” device will appear on the screen. Press the “+” button on the right of the name.
7. After the gate controller is paired, the main LED blinks yellow 3 times.
8. In the “Configuration” tab you can set the device name. In the “Channels” tab you can move to more advanced gate and lighting control settings.

### Removing a gate controller from the TR7 central unit

1. Move to the gate control from the Exalus Home application.
2. Press “...” in the right upper corner and next press the “Channel settings”.
3. Press the “Device settings”, and next “Remove the device”.

*NOTE: The gate controller will no longer be paired with the TR7 central unit if default settings are reset in the SBR-BIDI controller (see: 5. Reset of the gate controller). It will be visible in the application but the two devices will no longer communicate, which will be signalled with a red exclamation mark near the SBR-BIDI icon.*

## 5. Resetting a gate controller

1. Disconnect the controller from power supply and connect it again after a couple of seconds.
2. When the LED blinks alternately green and blue, press the correct button on the controller, and next release it when the LED goes off:
  - UP – restores the default settings of the controller, the main LED blinks green twice, and next it will blink blue and red signalling that the device is not calibrated.
  - STOP – erases all programmed transmitters, the main LED will blink green twice.

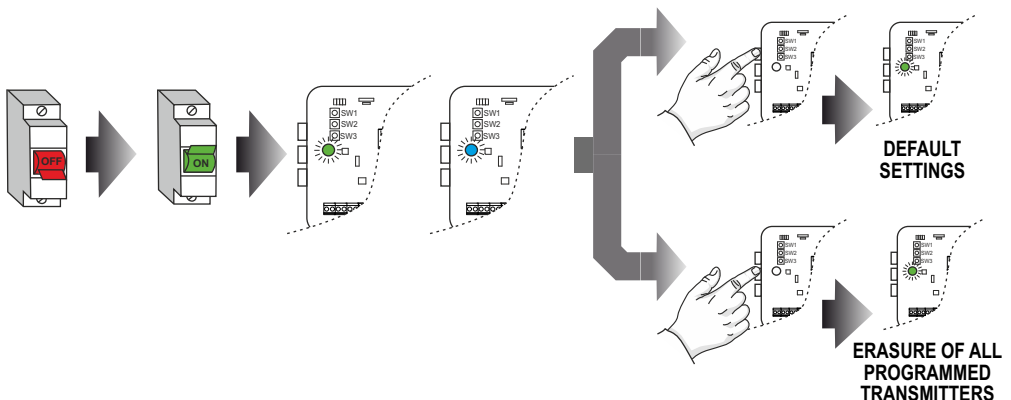

## 6. Gate controller response to protections

*NOTE: The inertia brake and the (resistive/optical) safety edge are the absolutely required components. If they are not connected, the gate controller will not be able to control the motor that is connected to it.*

*NOTE: It is necessary to connect the autotest photocells to control the device from the application level after it is paired with the TR7 central unit.*

### **Resistive/optical safety edge**

When the safety edge detects an obstacle during the downward movement, the gate is stopped and will start moving upwards, the D6 LED will start glowing.

The controller will not react when the safety edge is pressed during the upward movement.

An error identified by the resistive safety edge prevents any option of moving the gate down. The upward movement is possible with certain restrictions:

From the remote control level - holding the "UP" button (or the control button on the key fob) for 5 seconds will open the gate up to the perforation opening level (a slight opening of the gate). This movement can be repeated until the gate is fully opened.

From the wall-mounted switch or the gate controller level - holding the "UP" button will move the gate for as long as the button is pressed and held, if it is released, the gate will stop moving.

*NOTE: The resistive safety edge may detect an error if the subbase is uneven. To eliminate such an error, level the subbase or set the bottom limit position higher.*

### **Photocells**

If an obstacle interrupts the photocell beam between the transmitter and receiver while the gate is closing, the gate will stop and reopen. The D5 LED will start glowing.

The controller will not react during the upward movement of the gate.

An error identified by photocells prevents any option of moving the gate down. The gate's upward movement can be controlled without any restrictions using the gate controller, remote control, or mobile application. Only one upward movement is possible when using the wall-mounted switch.

*NOTE: An error signalled by the LED may also designate erroneous settings on DIP electrical switches. The description is provided in the electrical diagram on page 3.*

### **Inertia brake**

If the inertia brake is activated (for example, if the gate closes too quickly), the safety circuit is interrupted, the motor is immediately disconnected from the power supply and cannot be restarted. The D7 LED will start glowing. The gate curtain can only be moved again in the emergency lifting system (NHK) mode, or after replacing the old inertia brake with a new one.

### **Warning light**

The warning light signals when the gate is moving and is essential for the safety of people nearby.



The light turns on automatically during the gate opening and closing, and remains on while the gate is in motion.

The light must be connected to the correct output, as indicated in the electrical diagram.

### Zone indicator light

The zone indicator light illuminates the area around the gate to improve visibility when manoeuvring a vehicle, especially after dusk.

It can be activated automatically during the gate opening, and the illumination time can be set via the Exalus Home application (if the controller is paired with the TR7 central unit).

The zone indicator light can also be manually activated from the application level or via the STOP button on the gate controller or the 3-button remote control.

*NOTE: The warning light or zone indicator light may malfunction if connected incorrectly. Make sure that the lights meet the parameters of the controller and are connected in accordance with the electrical diagram.*

## 7. Troubleshooting – LED Indicator Table

Marking	LED COLOUR	MEANING/STATUS	REMARKS
Main LED (RGB)	● / ● (blinking)	The device is not calibrated	The first launch mode, no control option from the application or remote control level
	● (permanent light)	Calibration mode - upward movement	Awaiting the configuration of the upper limit position
	● (permanent light)	Calibration mode - downward movement	Awaiting the configuration of the lower limit position
	● (permanent light)	Transmitter pairing mode	Readiness for adding a remote control or the TR7 central unit
	● (permanent light)	Calibration completed, the device is ready	Readiness for operation
	● ● ● (3 quick blinks)	Calibration interrupted – protection device error	Check the edge strip, photocell, brake
	● ● (2 blinks)	Reset to default settings completed	After pressing the UP button at the start of movement
	● ● ● (3 blinks - red light)	Erasure of a paired transmitter	Check the safety protection systems
D1	● / None	Button-level control	Activation of the SbS input (monostable button)
D2	●	The bottom reed switch input (IN_K1)	The LED is glowing when the bottom reed switch is closed (an option to indicate the lower position)
D3	●	The upper limit reed switch input (IN_K2)	The LED is glowing when the upper reed switch is closed (an option to indicate the upper position)
D4	● (permanent light)	Active 24V DC power supply	Correct voltage for peripherals - the light is permanently on
D5	●	A photocell error/beam interruption	LED is glowing: an obstacle or an error. The LED blinks for 10 minutes after the self-test error has cleared
D6	●	An error of the resistive/optical safety edge	LED is on: an error or short circuit has been detected. The LED blinks for 10 minutes after the error has been removed
D7	●	Powering the device	LED is on: Power supply correct
D8	●	An error of the inertia brake	Safety circuit is interrupted - the motor is immediately disconnected from the power supply