

# ZD611R Desktop Printer



## Quick Start Guide



### 1 Setup

**IMPORTANT**  
Go to [zebra.com/setup](http://zebra.com/setup)  
and install the driver for your printer.

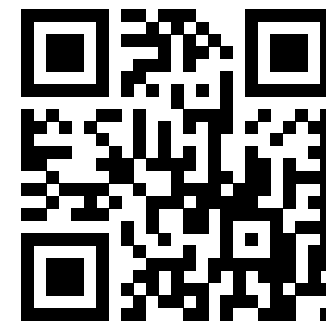

[zebra.com/setup](http://zebra.com/setup)



The driver **MUST** be installed before connecting the printer to the computer, or it will cause complications. If your Microsoft Windows-based computer does not have the driver installed for this printer, download it from [zebra.com/setup](http://zebra.com/setup) and install it before continuing.

### 2 Remove Packing



Slide the release latches (1) to the front to unlock the cover.

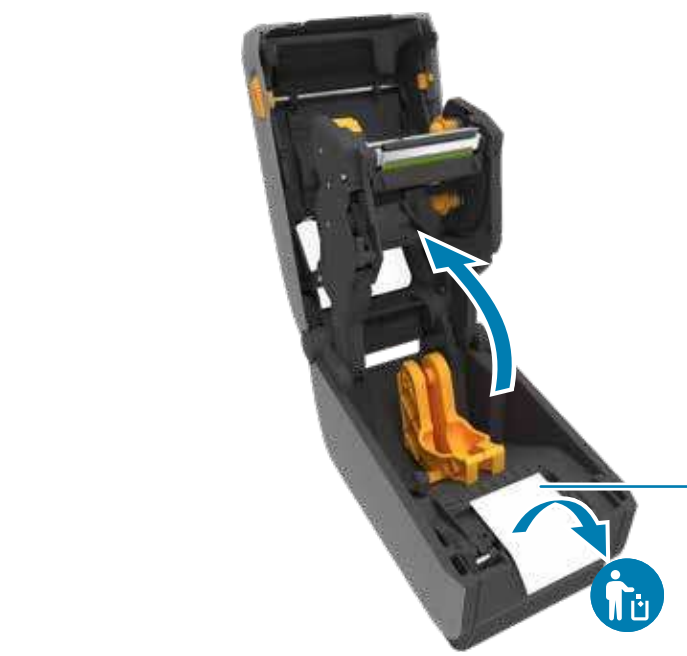

Open the printer and remove the packing (1).

### 3 Load Media

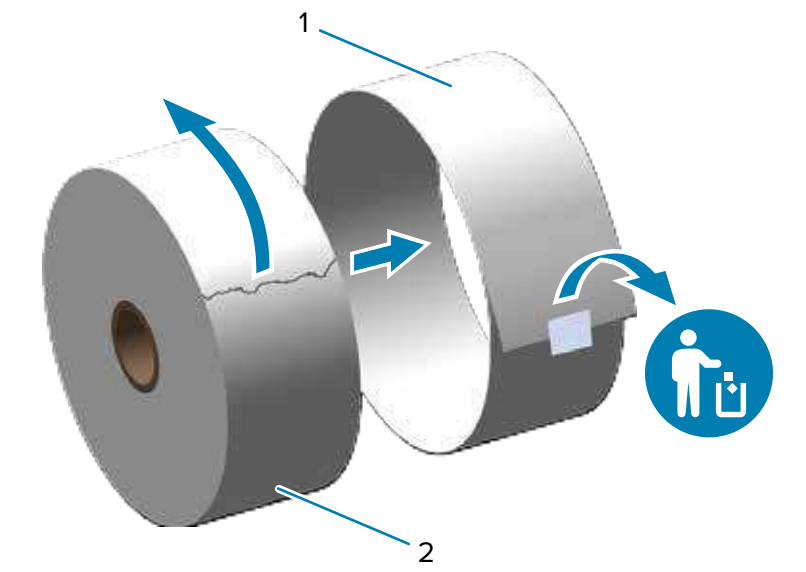

Unroll and discard the outer layer (2) of the media roll (1).

### 3 Load Media (continued)

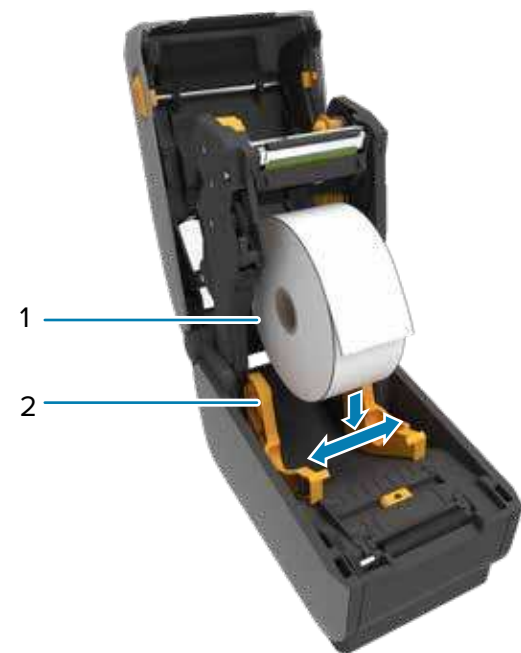

Spread the roll holders (1) open and place the roll (2) into the printer.



Verify the roll spins easily on the holder.



Pull the end of the roll past the front edge of the printer.

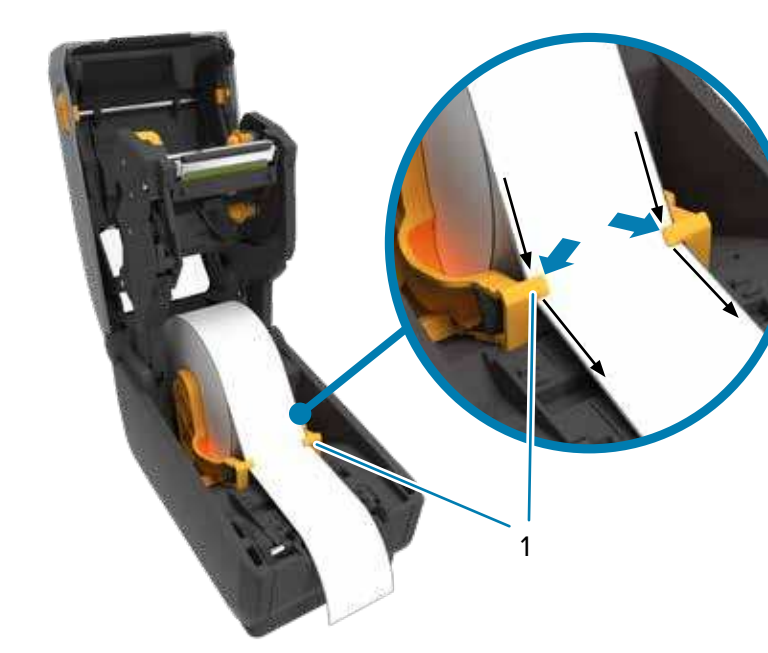

Press the media under the guides (1).

### 5 Adjust Sensor



Align the sensor (1) to the center of the roll for regular labels and receipts.

### 5 Adjust Sensor (continued)

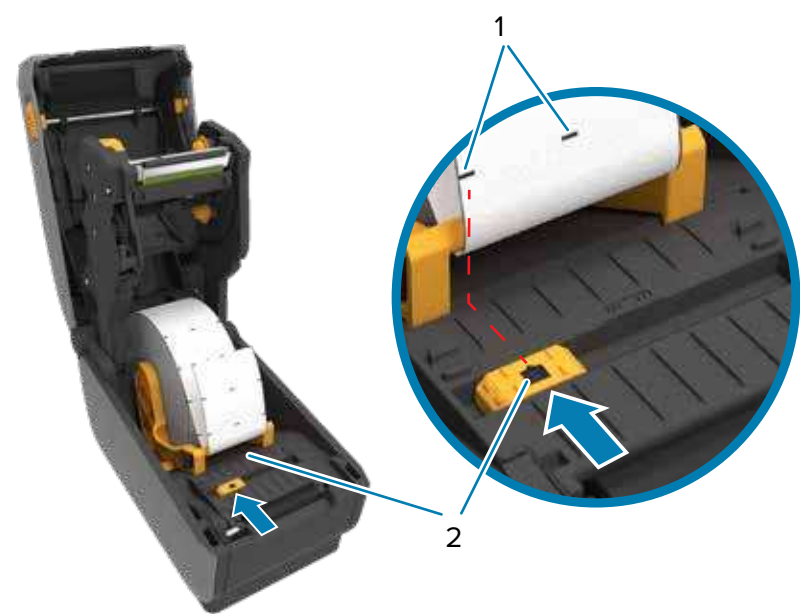

Align the sensor (2) to marks (1) away from the center of the roll for marked labels.

### 4 Load Ribbon

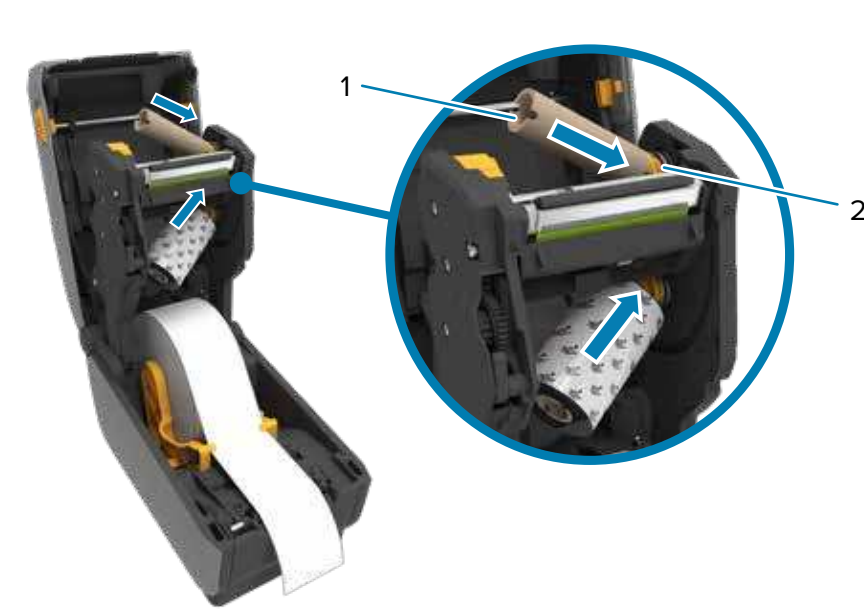

Push the right side of the spool (1) onto the spring-loaded spindle (2).

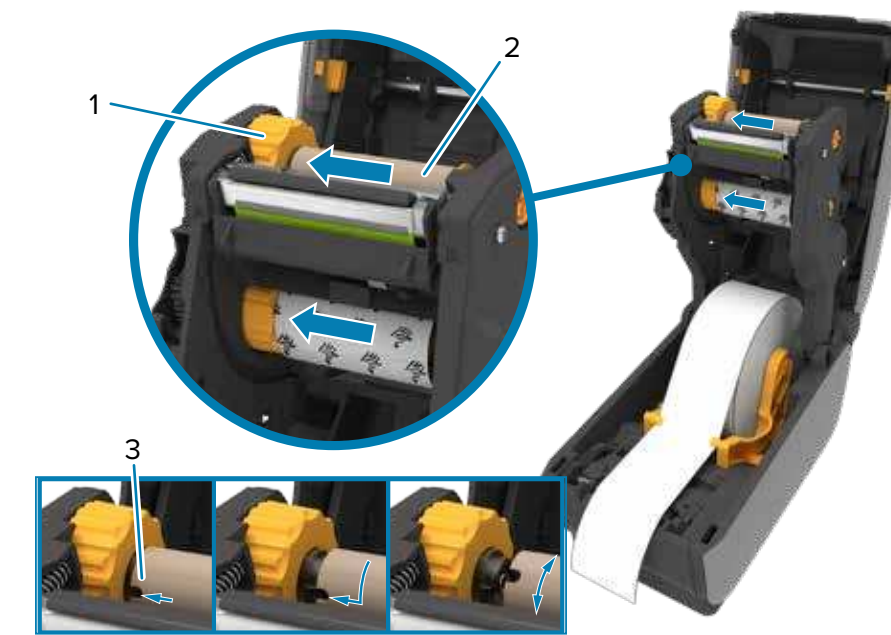

Place the left side of the spool (2) on the spindle (1) aligning it with the notches (3).

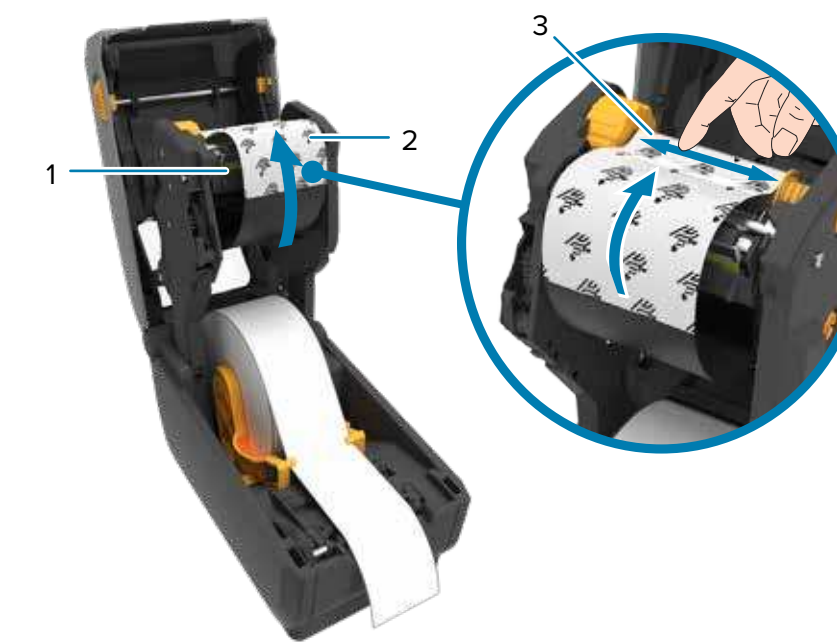

Pull the supply ribbon leader (2) up and over the printhead (1) and attach it to the take-up spool (3).

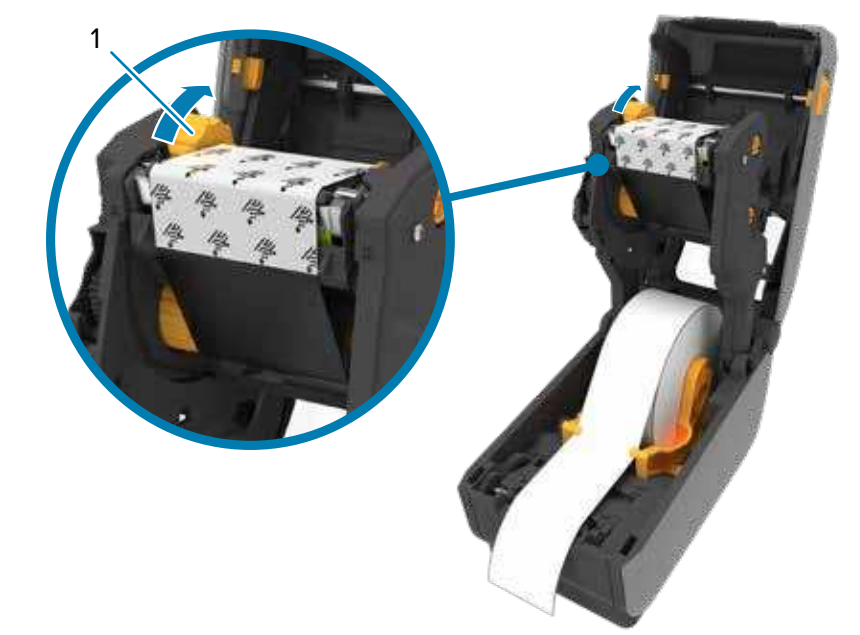

Turn the ribbon take-up wheel (1) to remove the slack and advance the ribbon.

## 6 Close Printer



Push down on the front edge of the printer until it locks.

## 7 Connect Power

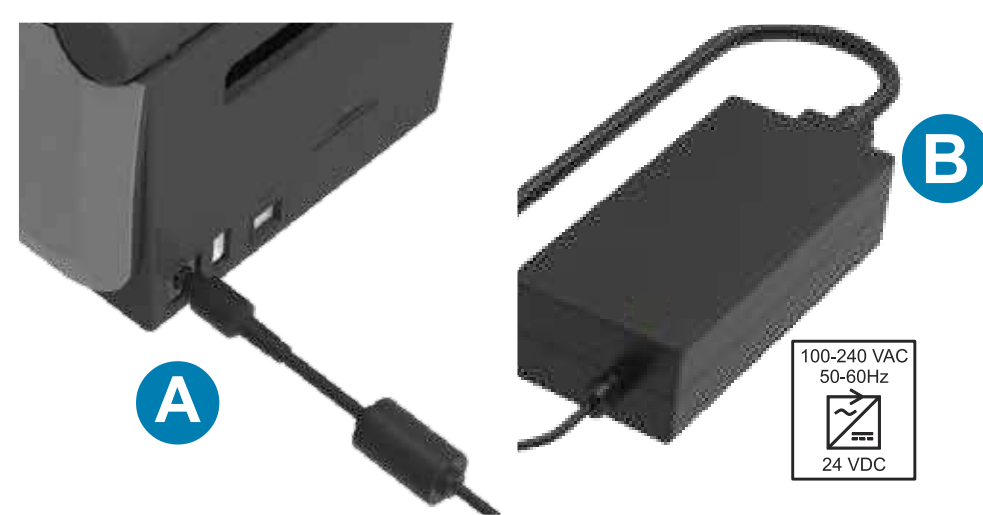

A. Plug the power supply into the printer.  
B. Plug the power cable into the power supply.



C. Plug the power cord into an appropriate receptacle.  
D. The power supply lights green.

## 8 Connect USB

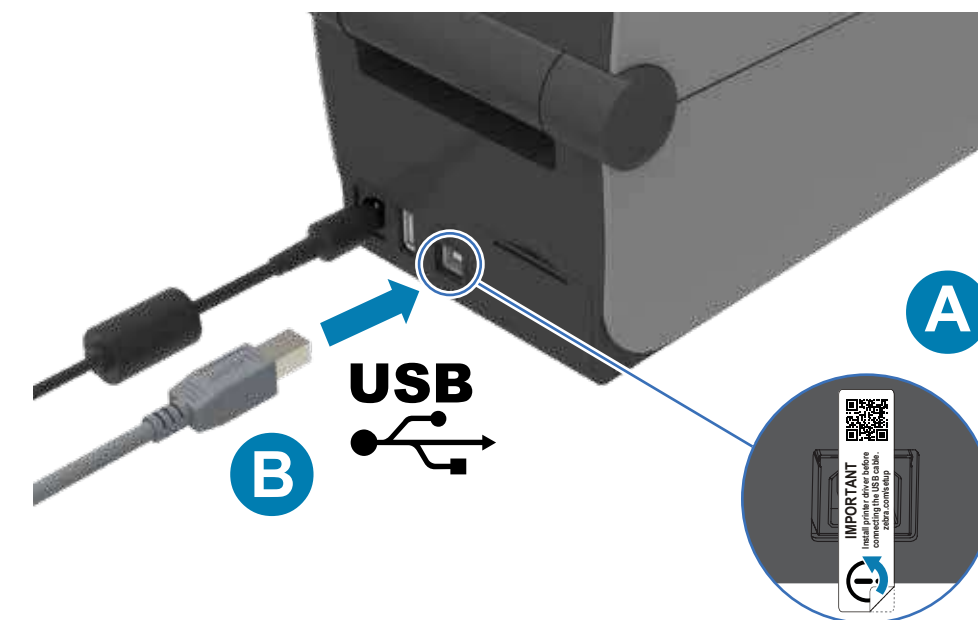

A. Remove the port blocker label.  
B. Connect the USB cable to the printer and your computer.

## 9 Power On



Press the power button (1).

## 9 Power On (continued)



When the printer is ready, the printer status light (1) will turn green.

## 10 Smart Calibration



Press and hold the Pause (1) and Cancel (2) buttons for two seconds to line up the labels.

## 11 Print Configuration Report

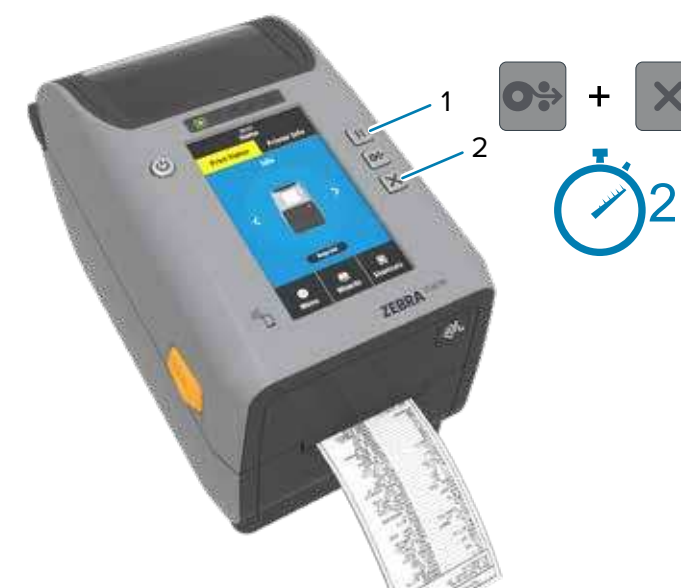

Press and hold the Feed (1) and Cancel (2) buttons for two seconds to print a configuration report.

## Media Out



When the media runs out, the printer and media status lights (1) will turn red.



Open the printer and discard the empty roll (1).

## Support and Information

|  |  |   |  |  |  |
|--|--|---|--|--|--|
|  |  | View user documentation and how-to videos.<br><a href="https://zebra.com/zd611r-info">zebra.com/zd611r-info</a> |  | View Quick Answers and Knowledge Base.<br><a href="https://zebra.com/knowledge">zebra.com/knowledge</a>                                  |  |
|  |  | Need to design a label?<br><a href="https://zebra.com/zebradesigner">zebra.com/zebradesigner</a>                |  | Join Community Connection of Zebra users and ambassadors.<br><a href="https://zebra.com/supportcommunity">zebra.com/supportcommunity</a> |  |
|  |  | Learn about genuine Zebra supplies.<br><a href="https://zebra.com/supplies">zebra.com/supplies</a>              |  | Contact Zebra about your printer.<br><a href="https://zebra.com/contact">zebra.com/contact</a>   |  |
|  |  | Need to manage your printer?<br><a href="https://zebra.com/ppme">zebra.com/ppme</a>                             |  | Need to secure your printer?<br><a href="https://zebra.com/printsecure">zebra.com/printsecure</a>  |  |

## Cleaning

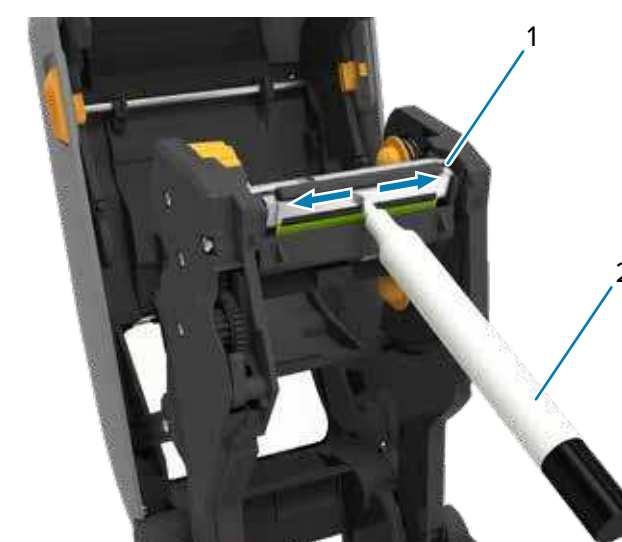

Clean printhead (1) with a cleaning pen (2). Clean from the middle to the outside. The cleaning pen is only for cleaning a printhead.

## Ribbon Out



When the ribbon runs out, the printer status and a flashing media status lights (1) will turn red.



Open the printer and discard the used ribbon. Keep the empty supply spool (2) to use for the next the ribbon take-up (1).



P1124876-01MIS

