



Installation and Maintenance

IM 1330-2

Group: Applied Air Systems

Part Number: IM 1330

Date: January 2022

Daikin Applied Self Contained Unit Controller MicroTech® II to MicroTech® III Unit Controller Conversion

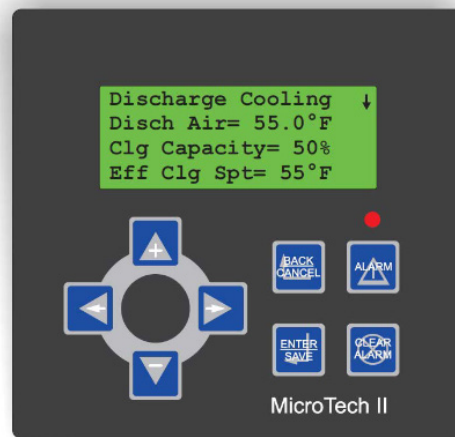

Introduction	3	Wiring Low Pressure Switches 3/4 Frost Protection Switches 3/4	16
Warnings and Disclaimers	3	Wiring Low Pressure Switches 5/6 Frost Protection Switches 5/6	16
Hazardous Information Messages	3	Wire Freezestat	17
Optional Parts	4	Wiring Water Flow Sensor	17
Network Communication Card	4	Wiring OAER Switch and Relay	18
Approximate Labor Hours	4	Wiring Modulating Heat Valve	18
Labeling Wires	4	Wiring Staged Heat	18
Installation	6	Wiring Waterside Economizer and Water Regulator/Bypass Valves	19
MicroTech I Display and Board Removal	6	Wiring Supply and Return Fan Enable	19
Removing Temperature Sensors, Pressure Sensors and Pressure Switches	6	Wiring the Supply Fan and Return/Exhaust Fan Variable Frequency Drives	20
Installing DIN Rails, MicroTech III Main Control Board, Expansion Modules, Relays, Terminal Blocks, and Wire Raceways	6	Wiring the Duct Static Pressure Sensor and Building Static Pressure Sensor	20
DIN Rails	6	Wiring of Network Communication Module	21
MicroTech III and Expansion Modules	7	Programming the MicroTech III and Variable Frequency Drive	22
Relays	7	Programming the MicroTech III	22
Terminal Blocks	7	Programming the Variable Frequency Drive	22
Wire Raceways	7	Appendix	23
Installing Remote HMI Display	7	Appendix A	23
Installing PC5, PC7, DHL Tubing and Duct Static Pressure Transducer	8	Appendix B	24
Installing Freezestat	9	Appendix C	26
Installing Actuators for Waterside Economizer	9	Appendix D	35
Installing Water Flow Sensor	9	Appendix E	36
Installing the Variable Frequency Drive	9	Appendix F	37
Wiring to the MicroTech III	11	Appendix G	42
Wiring the Terminal Blocks and Transformers	11	Appendix H	42
Wiring Power to the MicroTech III Main Control Board	12	Appendix I	43
Wiring Temperature Sensors	12	Appendix J	45
Wiring the S7 Switch, Smoke/Emergency Off, and External Time Clock/Tenant Override	14		
Wiring Fan Operation, Pump Signal and Alarm Output Circuits	14		
Wiring Pressure Switches (PC5, PC7 and DHL) and R63 Relay	15		
Compressor Enable (On/Off) Wiring	15		
Wiring High Pressure Switches 1/2 and R1/R2 Relays	15		
Wiring High Pressure Switches 3/4 and HP3/HP4 Relays	16		
Wiring High Pressure Switches 5/6 and HP5/HP6 Relays	16		
Wiring Low Pressure Switches 1/2, Frost Protection Switches 1/2, and Resistors	16		

Warnings and Disclaimers

The following compiles a list of warnings and notes associated with the installation and operation of this kit. Make sure to follow these warnings, as well as always having properly trained technicians and electricians, or Daikin-authorized technicians perform work.

Hazardous Information Messages

⚠ CAUTION

Cautions indicate potentially hazardous situations, which can result in personal injury or equipment damage if not avoided.

⚠ WARNING

Warnings indicate potentially hazardous situations, which can result in property damage, severe personal injury, or death if not avoided.

⚠ DANGER

Dangers indicate a hazardous electrical situation which will result in death or serious injury if not avoided.

⚠ DANGER

Dangers indicate a hazardous gas situation which will result in death or serious injury if not avoided.

ⓘ NOTICE

Notices give important information concerning a process, procedure, special handling or equipment attributes.

NOTE: This manual currently only supports the conversion of units with scroll compressors. Units with reciprocating compressors and unloading capabilities are not supported through this conversion document.

Parts Kit (300066936) Components

Description	Daikin Part Number	Quantity
Main Control Board - MTIII (MCB)	193407301	1
Expansion Module (EXP A,B, and C)	193407501	3
HMI Display	350147416	1
Controller Terminal Block - 2 pole	193410302	5
Controller Terminal Block - 3 pole	193410303	9
Controller Terminal Block - 5 pole	193410305	1
Controller Terminal Block - 6 pole	193410306	1
Controller Terminal Block - 7 pole	193410307	4
Controller Terminal Block - 8 pole	193410308	8
Terminal 2 x 2 spring Grey 2row Jumper Ports	349930641	20
Terminal 2x2 Spring Green 2row Jumper Ports (Ground)	349930647	5
Terminal Block End Stop Gray	874-144	10
Terminal Block End Plate Gray	349930741	10
Terminal Block Jumper 2 Pole	349930942	3
Terminal Block Jumper 3 Pole	349930943	3
Terminal Block Jumper 4 Pole	349930944	3
Terminal Block Jumper 5 Pole	349930945	10
Discharge Air Temperature Sensor (DAT)	193414602	1
Return Air Temperature Sensor (RAT)	332519704	1
Mixed Air Temperature Sensor (MAT)	193414602	1
Entering Water Temperature Sensor (EWT)	193414602	1
Sensor Plate	9101156960	2
Sensor Support	0497596010	2
Zone/Space Sensor w/ Tenant Override and Setpoint Adjust	910143408	1
Freezestat (FS1)	072502001	1
24 VAC, 0-10VDC Actuators (ACT 3 and ACT 4)	113139501	2
Relay Subbase	193413701	2
24 VAC Relays (OAER and R63)	193413601	2
DIN Rails (1 Meter)	349901938	2
White Wire Organizers 2" Depth	300044173	16
White Wire Organizers 2" Depth Cover	300044174	16
1 k ohm resistor for freezestat	044690110	2
1.5k ohm resistor for frost protection	044690151	1
Connector Set for Extension	193409401	3
Refrigerant Pressure Transducer (PSR 1,2)	331764611	2

NOTE: Additional Parts Required

- Label Maker
- 18 AWG Wire
- Spade Connectors

Optional Parts

The following parts are optional for the unit. Verify before starting conversion.

Description	Daikin Part Number	Quantity
Duct Static Pressure Sensor (SPS1)	910117462	1
Building Static Pressure Sensor (SPS2)	910117463	1
Entering Air Temperature Sensor	193414602	1
Leaving Air Temperature Sensor	193414602	1
Exhaust Air Temperature Sensor	193414602	1
Humidistat Sensor (units with frost protection)	910190890	1
Humidistat Sensor Support	910194091	1
Humidity Sensor, Duct mounted	910190890	1
Humidity Sensor, Wall mounted	067294901	1

Network Communication Card

Choose a Network Communication Card from the list below if required. A 10 pin connector will also be required with a Communication Card.

Communication Card Type	Part Number
BACnet MSTP	90016710
BACnet Lon CAV	90016711
BACnet IP	90016709
BAC Lon VAV	90016712
10 pin connector	300047027

Approximate Labor Hours

The MicroTech II to MicroTech III conversion process will require an estimated 32-48 hours of labor. The specified range of time required for completion is only to be used as a general guideline when preparing for the conversion process. Please note that the capabilities and experience of the service technician performing this work, as well as the individual jobsite conditions, could significantly affect the labor hour estimates.

Introduction

The purpose of this instruction manual is to guide a technician through the process of converting a MicroTech II (MT II) control panel to a MicroTech III (MT III) control panel on a Self-Contained unit. This manual currently only supports the conversion of units with scroll compressors. Units with reciprocating compressors and unloading capabilities are not support through this conversion document. The MicroTech III controller has an advanced navigation structure, improved metrics, trending data capability and network integration compatibility. Each Self-Contained unit will have small differences, such as the number of compressors or using a Variable Frequency Drive for the supply fan. Recognizing these differences and following the instructions throughout the manual will ensure a successful conversion.

 **NOTICE**

Follow all Lock-Out Tag-Out procedures to minimize risks of injury during this procedure. Always use proper rigging and lifting procedures! Always wear appropriate levels of PPE governed by the hazards which are present..

Labeling Wires

Figure 1 shows a typical control panel layout. Look for three to four electrical control boards mounted to the control panel: Main Control Board (MCB), Network Communication Board and Auxiliary Board(s) (See Figure 2, 3, and 4). The Network Communication Board will be mounted on top of the Main Control Board. Each Auxiliary Board will appear to be identical. The programming within each of the Auxiliary Boards defines its function. The only type of Auxiliary Board present in a Self-Contained unit will be the Compressor Control Boards (CCB). Reference IM 710 for more information on these boards. Before removing the three boards, each of the wires connected to the boards must be labeled with a label maker. Refer to charts in Appendix I and Appendix J for information on wire labeling. Labeling the wires will allow the technician to be more organized and rewire the control panel correctly once the MicroTech III is installed.

NOTE: The Unit Type in the Unit Configuration set in the MicroTech II controller influences the wiring options for each board. The technician will need to know the Unit Type to decide which wiring chart to follow in Appendix I and J. If the Unit Type = 0 or 2, use the Space Comfort Control (SCC) charts. If the Unit Type = 1 or 3, use the Discharge Air Control (DAC) charts.

Figure 1:

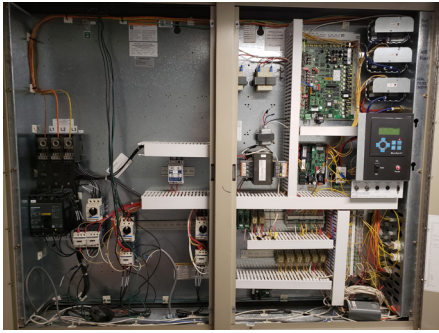

Figure 2:

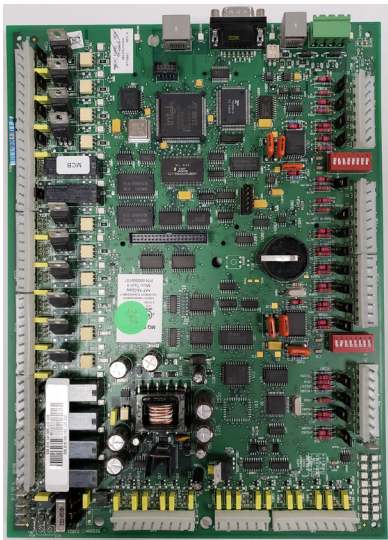

Figure 3:

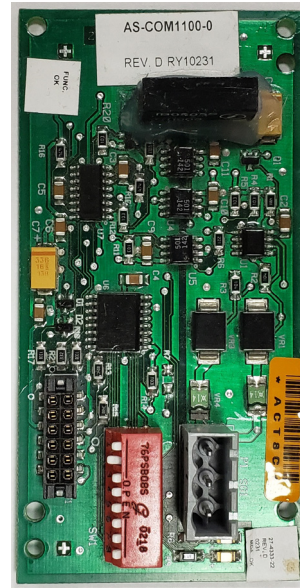

Figure 4:



MicroTech I Display and Board Removal

Once each of the wires are labeled, follow the directions below. Figure 5 shows the control panel with all wiring labeled and boards removed (not including the MicroTech II display).

1. Unplug all wires from Main Control Board and Auxiliary CCBs. Leave all paired wires in their respective plugs to keep them organized.
2. Unscrew each of the boards from the control panel.
3. Remove the wires from the back of the MicroTech II display.
4. Unscrew the MicroTech II display and remove from the control panel.

Figure 5:

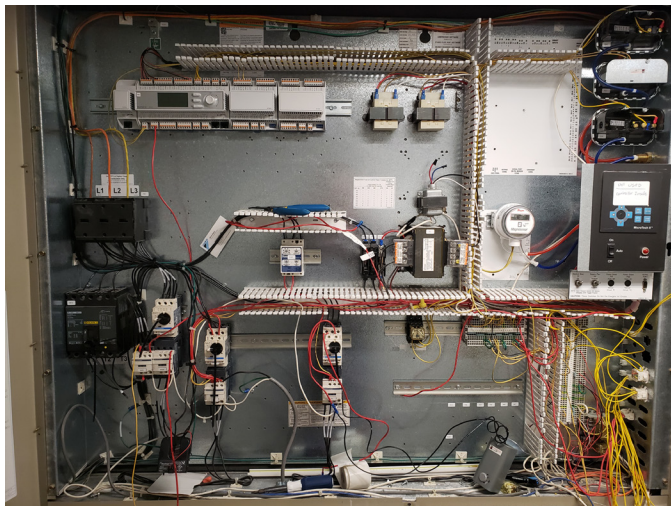

Removing Temperature Sensors, Pressure Sensors and Pressure Switches

The following temperature sensors will need to be removed from the unit: Zone/Space Sensor DAT, RAT, OAT, MAT, LWT, EWT. Be aware and take note of the mounting location for each of these sensors because new sensors will be remounted and wired to the MicroTech III Main Control Board later in this manual.

The PC5, PC7 and DHL do not need to be removed. Replace tubing if necessary. Be aware and take note of the high and low side of pressure designations to avoid erroneous readings after installation.

Installing DIN Rails, MicroTech III Main Control Board, Expansion Modules, Relays, Terminal Blocks, and Wire Raceways

NOTE: Use the image in Appendix H as a guide when laying out the components in the control panel.

DIN Rails

One DIN rail is required to mount the MicroTech III, expansion modules and communication module in the control panel. This kit includes a one-meter piece of DIN rail. Follow the directions below when installing the DIN Rail(s).

1. Cut the DIN rail to length as needed and position in the control panel as shown in Figure 6.
2. Use a level to ensure the components will mount properly to each DIN Rail.
3. Screw through the DIN rail holes and into the control panel sheet metal backing.
4. Adjust DIN rail(s) as needed because space is limited within the control panel.

Figure 6:

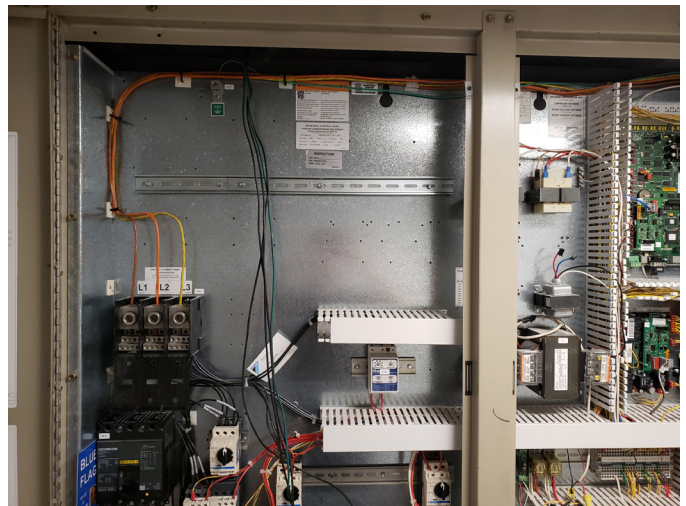

MicroTech III and Expansion Modules

Follow the directions below when installing the MicroTech III and Expansion Modules. Refer to chart in Table 1 to determine which Expansion Modules are required based on the unit's features.

1. Slide the MicroTech III Main Control Board onto the DIN rail and engage the tabs to secure it in place. Depending on the unit, one or more Expansion Modules may need to be connected to the MicroTech III Main Control Board.
2. If an Expansion Module is installed adjacent to the MicroTech III Main Control Board or other Expansion Module:
 - a. Slide the 4-pin connector into the left side of the Expansion Module.
 - b. Slide the other end into the right side of the MicroTech III Main Control Board or other Expansion Module. Multiple Expansion Modules can be mounted to the right of the prior module.
3. If the Expansion Module is not able to be installed next to the MicroTech III Main Control Board or other Expansion Module:
 - a. Slide the 4-pin remote connector for the remote Expansion Modules into the left side of the Expansion Module.
 - b. Wire the 4-conductor signal cable to the remote connector.
 - c. Wire the other side of the cable to the second 4-pin remote connector.
 - d. Slide the connector into the MicroTech III Main Control Board or other Expansion Module.
4. Once each of the Expansion Modules are installed, they must be addressed by setting the dip switches. In the lower right corner of an Expansion Module, there are six white switches with blue backing. Appendix A shows how these dip switches should be set, depending on the type of Expansion Board.

NOTE: The last Expansion Module must have the sixth dip switch in the "up" position. The sixth switch acts as an end-of-line resistor and stops the MicroTech III from looking for more Expansion Modules. See Appendix A for details.

Figure 7:

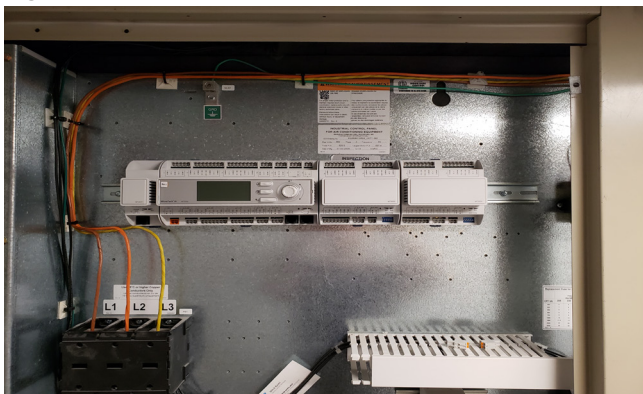

Table 1: Unit Features

Unit Features	Expansion Module A	Expansion Module B	Expansion Module C
Duct Static Pressure	X		
Relative Humidity	X		
CO2 Sensor	X		
Water Flow Switch	X		
Heating		X	
Compressorized Cooling Circuits 1-4			X
Compressorized Cooling Circuits 5-6	X		X

Relays

High Pressure Switch 1 (HP1), High Pressure Switch 2 (HP2), High Pressure Switch 3 (HP3), and High Pressure Switch 4 (HP4) each require a relay (R1, R2, R3, R4) to indicate a high pressure alarm on the MicroTech III. There may be more or less than four compressor circuits in the unit. These four relays already exist in the unit. If any of the High Pressure Switches open, their respective relay will de-energize and the set of dry contacts will open. This will open the circuit to generate a high pressure alarm on the MicroTech III. The R63 relay is necessary to indicate when the DHL switch is open. The R11 relay is required as part of the Water Flow Switch function. The R26 Relay may exist and is required for the Fan Operation Output Signal function.

Slide the necessary relays onto the DIN rail. Spacers can be used to separate the components on the DIN rail.

NOTE: If the unit does not have a Water Flow Switch or one is not required, relay R11 is not necessary.

Terminal Blocks

The MicroTech II control panel consists of two types of terminals blocks: general wiring terminal blocks and power terminal blocks. The general wiring terminal blocks are used for circuit interconnections and the power terminal blocks are used for a source of 24 VAC or 115 VAC power. The MicroTech II control panel should already be set up for these types of terminal blocks. However, reconfiguring and organizing the terminal blocks to may be necessary to support this conversion. Please see the Terminal Block Wiring part of this manual for more information.

Wire Raceways

The white wire raceways are designed to ensure an organized control panel. Mount the wire raceways as shown in the diagram in Appendix H. Fasten wire raceways to the control panel with screws.

Installing Remote HMI Display

Install the Remote HMI Display above the control panel in place of the old MicroTech II display. Mount the Remote HMI Display by using the magnets or the screw terminals with anchors found on the back of the display. See IM-1005 for details on wiring.

Installing PC5, PC7, DHL Tubing and Duct Static Pressure Transducer

Install new tubing for the pressure switches, if necessary, and confirm that it matches the diagram in Figure 8. See Figure 10 for an example of PC5, PC7 and DHL pressure switches installed in the unit. If the unit requires a Variable Frequency Drive and the supply fan is designed to run off a Duct Static Pressure set point, a Duct Static Pressure transducer (DSP) will need to be installed. If there is a Duct Static Pressure transducer currently installed in the MicroTech II control panel, it will need to be replaced. The Duct Static Pressure is installed by mounting it on a 6-inch piece of DIN rail. See Figure 9 below and Appendix H for mounting control panel mounting location.

Figure 8: New DSP Tubing Diagram

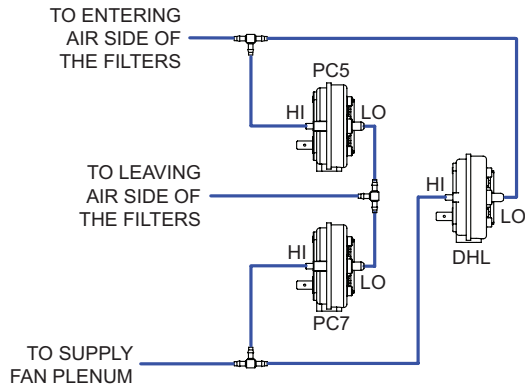

Figure 10:

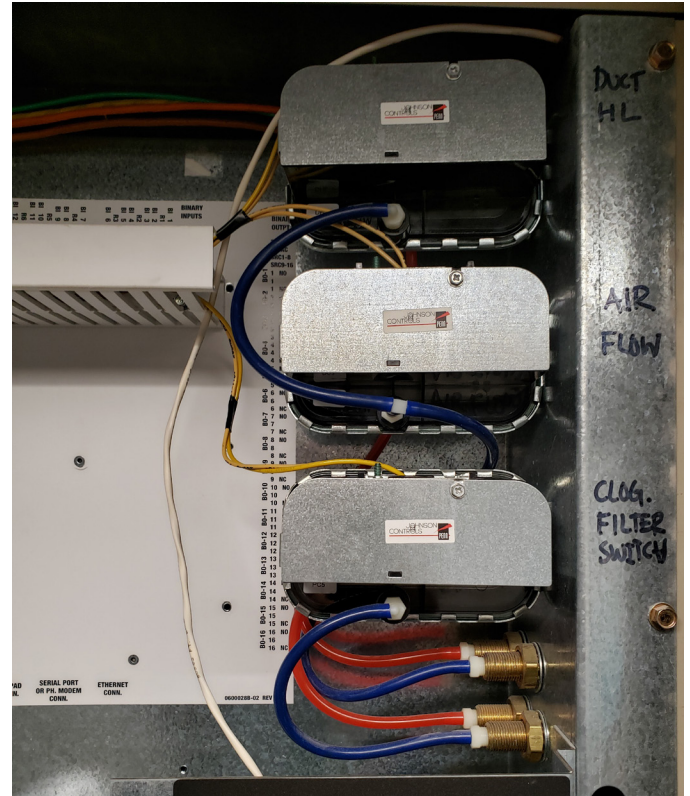

Figure 9: Duct Static Pressure (DSP) Transducer



Installing Freezestat

A non-averaging type freezestat (FS1) is used to protect hydronic coils from subfreezing temperatures. The control is mounted on the entering face of the economizer coil. Upon sensing a temperature above specification, the unit shuts down, opens the hydronic control valves, and sends an alarm indication via the MicroTech III controller. The freezestat has a field-adjustable set point range of 35°F to 45°F. To change the set point, turn the adjustment screw until the pointer is opposite the desired cutout point. The adjustment screw is accessible at the bottom of the freezestat switch or at the top when the cover is removed.

Installing Actuators for Waterside Economizer

A unit with Waterside Economizer Application requires two valves controlled by separate actuators. One valve is for the economizer and the other valve is for the water regulator/bypass. Each of these valves has their own actuator, but function oppositely from each other. When the economizer valve opens, the water regulator/bypass valve will close and vice versa. Each actuator will need to be mounted with its polarity wired for direct or reverse acting function. A 0 VDC signal will fully close the economizer valve and the water regulator/bypass valve will be fully open. A 10 VDC signal will fully open the economizer valve and the water regulator/bypass valve will be fully closed. See Figure 11.

NOTE: There may be several different types of valves currently installed depending on the age of the unit. The waterside economizer and water regulator/bypass valves currently installed in the MicroTech II Self-Contained Unit use floating point control. The MicroTech III Controller only supports direct, analog signal control. If the valves cannot be commanded using a 0-10 VDC signal, they will need to be replaced. Field modification may be required before installing the actuator.

Figure 11:



Installing Water Flow Sensor

If the unit contains a water flow sensor, it does not need to be replaced. Relay R11 is wired to the output of this switch to close a set of dry contact, which will complete a circuit on the MicroTechIII indicating water flow. If there is not a Water Flow Sensor, a jumper will need to be wired to the Main Control Board to avoid nuisance alarms on the MicroTech III. The wiring is described later in this manual.

Installing the Variable Frequency Drive

A unit designed for a Variable Air Volume Application will need a Variable Frequency Drive installed for desired operation. The Variable Frequency Drive can be mounted using screws on the outer frame of the unit to the left or right of control panel. Two holes need to be drilled below the Variable Frequency Drive and into the control panel for power and signal wiring conduit. See Figure 12 and Figure 13.

NOTE: If the unit already contains a Variable Frequency Drive, it must be able to be commanded through Modbus in order to properly function with a MicroTech III controller. Daikin only supports installing ABB (ACS320, ACH550, and ACH580), Schneider (ATV212) or Danfoss (FC102) Variable Frequency Drives to properly function with the MicroTech III controller. The installation location of the Variable Frequency Drive is dependent on choice of the technician. They must choose a location with proper ventilation to avoid overheating. An example of an ABB Variable Frequency Drive mounting is shown in Figure 12 and 13.

Figure 12: Actuators for Waterside Economizer



Figure 13: Actuators for Waterside Economizer



Wiring to the MicroTech III

NOTICE

Power must NOT be applied to the MicroTech III or other devices when wiring to the controller.

After the sensors, switches, relays, actuators, controllers and modules are installed, the wiring to the MicroTech III can begin. A full wiring diagram can be found in Appendix B. Use the wire raceways around the edges of the control panel to ensure neatness and terminate wires on the MicroTech III correctly. Terminating an energized wire on the incorrect terminal could open the internal MicroTech III fuse and effect the operation of the controller.

Wiring the Terminal Blocks and Transformers

Terminal Blocks

The MicroTech II should have two terminal blocks installed in the control panel. In order to keep the panel and wiring organized through this conversion, it is recommended that the terminal blocks be reconfigured as shown in Figure 14 and 15.

When re-wiring the unit, there will be a need for two power terminal blocks, 24 VAC and 115 VAC, each designated for a specific voltage potential. The individual green terminal blocks can be used as ground/common for each separate voltage potential. Mechanical jumpers must be installed across each of the power terminal blocks in order to create an equal potential through the block. The individual green terminal block pieces will be grounded to the unit's case through the DIN rail. Each side of Terminal Block 1 can source its power from the transformers in the unit. For example, the secondary of the 115 VAC to 24 VAC transformer will be wired into the 24 VAC + and Common/Ground side of Terminal Block 1.

Terminal Block 3 will be a set of general terminal blocks used for general wiring of the unit. General wiring includes relay circuitry and high voltage component circuitry.

NOTE: Be cautious while setting up and wiring components to each terminal block. Some components only function with certain voltages.

Figure 14: Terminal Block 1 and Terminal Block 3

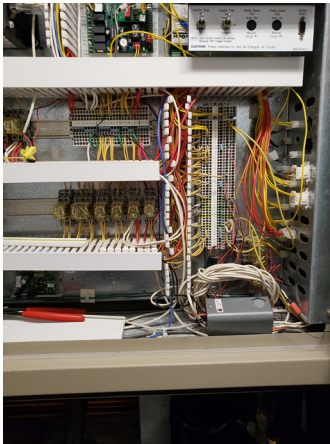
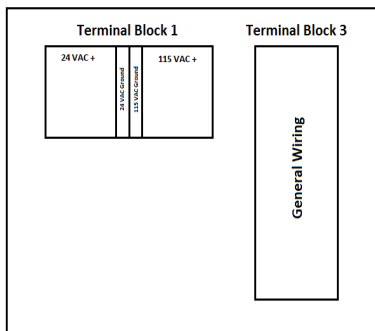

Figure 15: Terminal Block 1 and Terminal Block 3



Transformers

The secondary sides of the T1 and T2 transformers each consist of a positive (+) and a common potential. Wire secondary of each transformer to the correct locations on Terminal Block 1.

Wiring Power to the MicroTech III Main Control Board

The MicroTech III Main Control Board is powered by 24VAC from T2. On the Main Control Board, wire T1-G to 24 VAC + and T1-G0 to 24 VAC Common.

Wiring Temperature Sensors

Follow the directions below when wiring the temperature sensors to the MicroTech III.

1. Mount the DAT, RAT, MAT, OAT and EWT temperature sensors in the correct location.
2. Guide the wires for each sensor into the control panel.
3. Use the sensor plate and plastic sensor support when installing the DAT and RAT sensors.
4. Terminate the wires for each sensor as shown in the wiring diagram in Figure 16.

NOTE: The RAT sensor needs to be mounted far enough down the duct to avoid being influenced by the outside air temperature.

Figure 16: Sensor Wiring Diagram

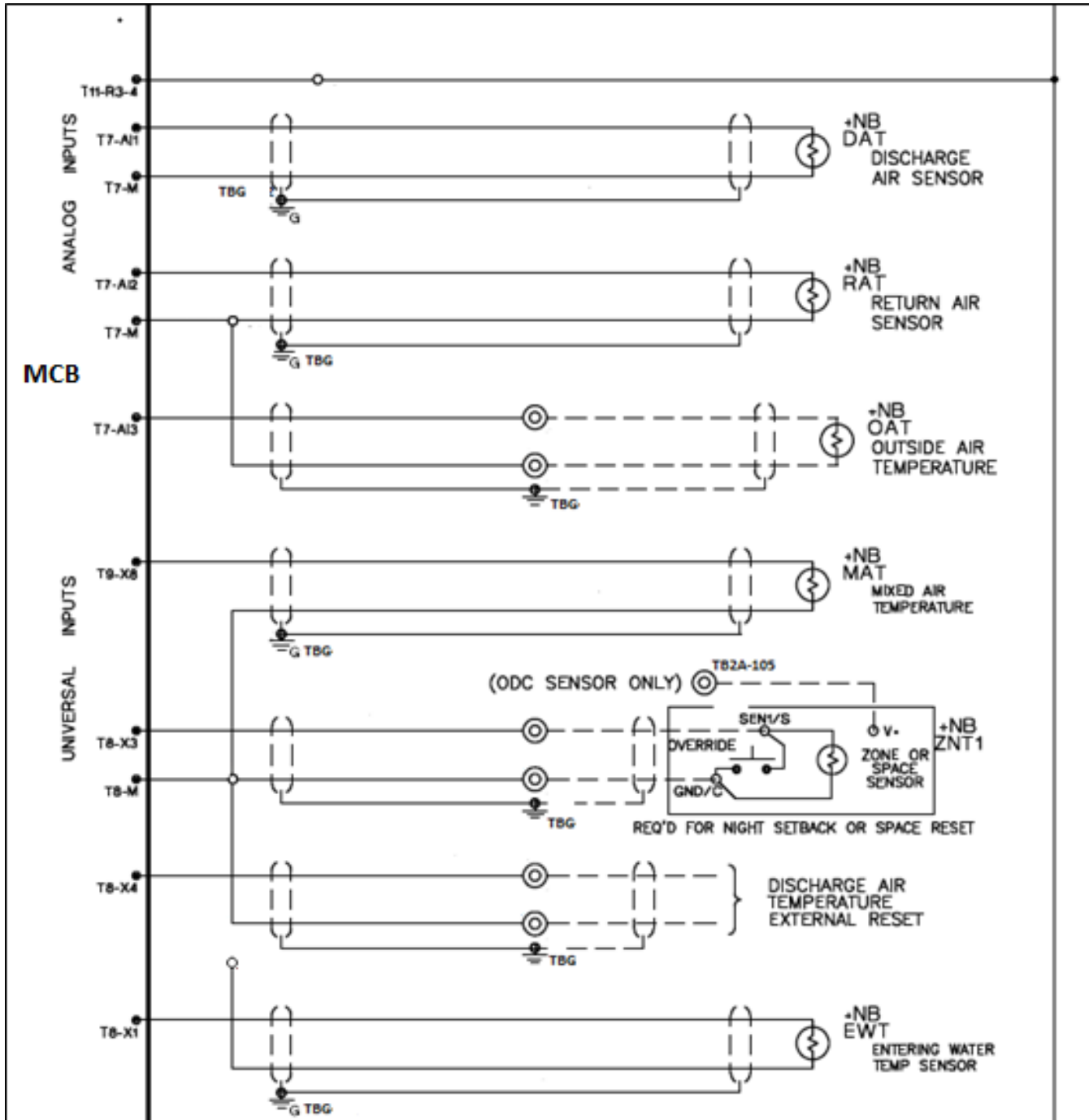

Wiring the S7 Switch, Smoke/Emergency Off, and External Time Clock/Tenant Override

A power source of 24 VAC needs to be supplied to the S7 Switch and Tenant Override circuit. The S7 Switch and External Time Clock/Tenant Override are wired in parallel to the MCB-DI3. When MCB-DI3 receives 24 VAC, the unit will be commanded into Occupied Mode. Wire the S7 Switch and External Time Clock/Tenant Override contacts (if applicable) as shown in Figure 17.

A power source of 24 VAC needs to be supplied to MCB-DI4 to allow the unit to run without an Emergency Off Fault alarm. The set of NC smoke detector contacts can be wired in series to MCB-DI4 as shown in Figure 17. When there is smoke detected, the NC contacts will open and 24 VAC will be removed from MCB-DI4 and cause an alarm.

Figure 17:

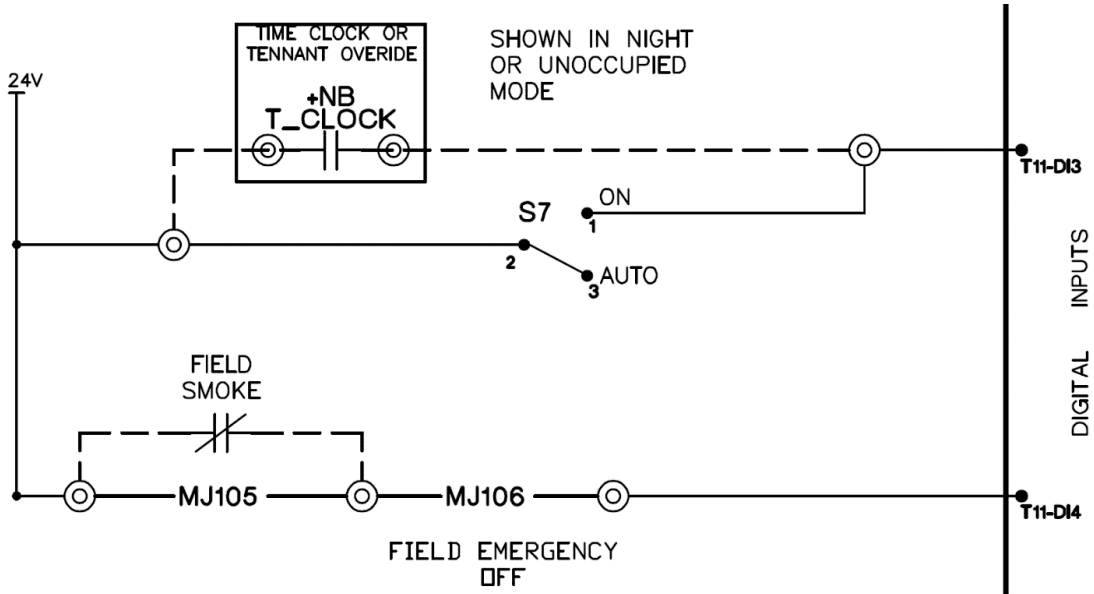

Wiring Fan Operation, Pump Signal and Alarm Output Circuits

If the MicroTech II Control Panel included External Alarm Output field wiring, Fan Operation field wiring, or Pump Signal field wiring, wire them to the specific Digital Output as shown by Figure 18. The Digital Output circuits are powered by 24 VAC and the relay coils must be rated at 24 VAC for proper function.

Figure 18:

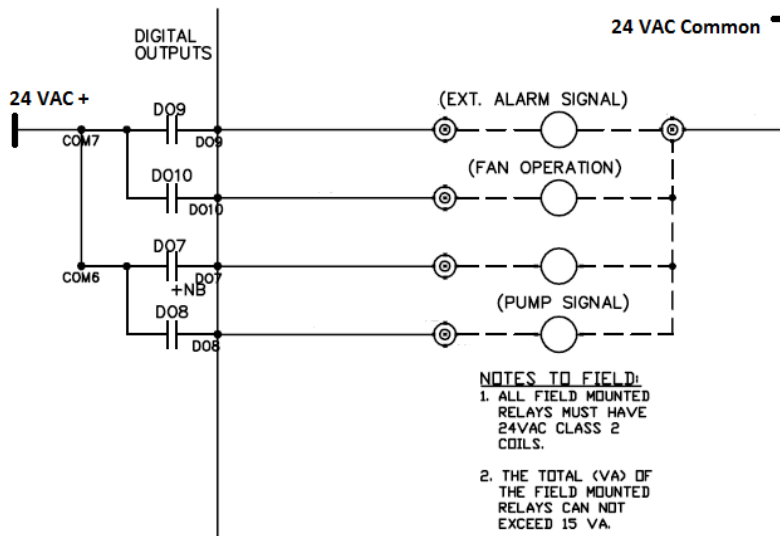

Wiring Pressure Switches (PC5, PC7 and DHL) and R63 Relay

The PC5 pressure switch wires directly to the MicroTech III as shown below in Figure 19. PC5 is a normally closed switch that completes a circuit between DI2 and M. If the switch opens, the circuit breaks and generates a dirty filter alarm.

The PC7 pressure switch is wired in series with the R63 NO contact and MicroTech III shown in Figure 19. PC7 is a normally closed switch that completes a circuit between DI1 and M. If the switch opens, the circuit breaks and an Airflow Fault alarm will occur after three attempts.

The DHL switch is wired in series with the R63 relay shown in Figure 20. The R63 relay is energized with 24 VAC from Terminal Block 1 as long as the DHL switch is closed. Two sets of NO dry contacts from the R63 relay are wired to the MicroTech III in DI1 and DI4 circuits and one set is wired into the Variable Frequency Drive.

NOTE: If the unit was selected for constant volume, then no DHL would be installed.

Figure 19:

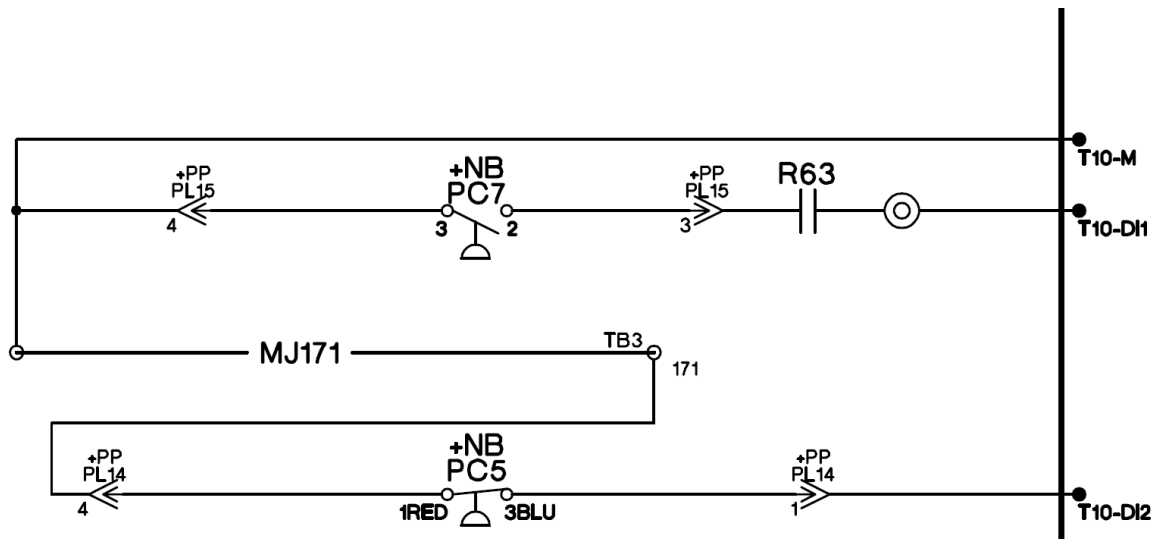

Figure 20:



Compressor Enable (On/Off) Wiring

Each fixed speed, scroll compressor is enabled or disabled through a Digital Output on the MicroTech III Main Control Board or Expansion Module A. Compressors 1-4 will be controlled through Digital Outputs 1-4 on the Main Control Board and Compressors 5-6 will be controlled through Digital Outputs 1-2 on Expansion Module A. Please see Appendix I and Appendix J for more information on wiring locations. In general, each compressor enable circuit includes a high pressure switch in series with the digital output, MMP, and compressor motor coil. When the high pressure switch is closed, the digital output is closed and the MMP is closed, the compressor motor coil will energize through 115 VAC. See Figure 21 for a wiring diagram reference.

Wiring High Pressure Switches 1/2 and R1/R2 Relays

R1 and R2 relay coils are wired in parallel to the HP1 and HP2 switches, respectively. When either of the high pressure switches open, the R1/R2 relays are de-energized and the 115 VAC circuit opens at DI5/DI6 on the MicroTech III Main Control Board. See Figures 21 and 22 for wiring.

Wiring High Pressure Switches 3/4 and HP3/HP4 Relays

The R3 and R4 relays are wired in parallel to the HP3 and HP4 switches. When either of the high pressure switches open, the R3/R4 relays are de-energized and their NO contacts open to break the dry X3/X4 and M circuit on the MicroTech III EXPC. See Figures 21 and 22 for wiring.

Wiring High Pressure Switches 5/6 and HP5/HP6 Relays

The R5 and R6 relays are wired in parallel to the HP5 and HP6 switches. When either of the high pressure switches open, the HP5/HP6 relays are de-energized and their NO contacts open to break the dry X7/X8 and M circuit on the MicroTech III EXPC. See Figures 21 and 22 for wiring.

Wiring Low Pressure Switches 1/2, Frost Protection Switches 1/2, and Resistors

For circuit number one, the LP1 and FP1 switches are wired in series with a 1.5kΩ resistor. For circuit number two, the LP2 and FP2 switches are wired in series with a 1kΩ resistor. The X2 input on the MicroTech III Main Control Board will read a resistance value input depending on which switch opens. Figure 21 shows the wiring for Low Pressure Switch 1 (LP1), Low Pressure Switch 2 (LP2), Frost Protection Switch 1 (FP1) and Frost Protection Switch 2 (FP2).

Wiring Low Pressure Switches 3/4 Frost Protection Switches 3/4

For circuit number three, the LP3 and FP3 are wired in series and into X1 on Expansion Module C. For circuit four, the LP4 and FP4 are wired in series into X2 on Expansion Module C. Figure 22 shows the wiring for the Low Pressure Switch 3 (LP3), Low Pressure Switch 4 (LP4), Frost Protection Switch 3 (FS3), and Frost Protection Switch 4 (FS4).

Wiring Low Pressure Switches 5/6 Frost Protection Switches 5/6

For circuit number five, the LP5 and FP5 are wired in series and into X5 on Expansion Module C. For circuit six, the LP6 and FP6 are wired in series into X6 on Expansion Module C. Figure 22 shows the wiring for the Low Pressure Switch 5 (LP5), Low Pressure Switch 6 (LP6), Frost Protection Switch 5 (FS5), and Frost Protection Switch 6 (FS6).

Figure 21:

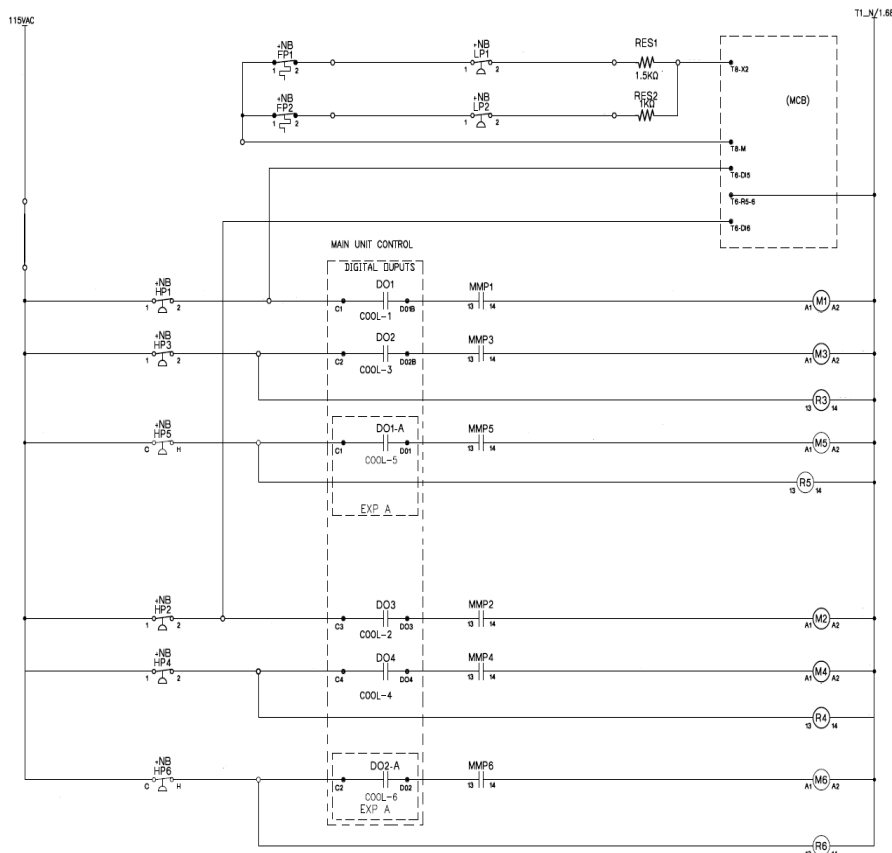
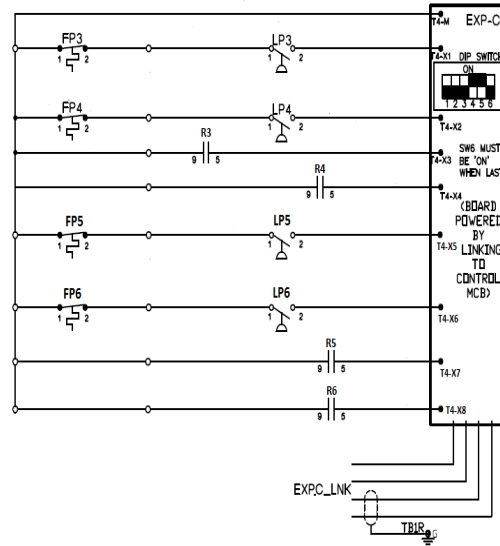

Figure 22:



Wire Freezestat

The Freezestat (FS1) is a temperature-based switch that is designed to open at low temperatures in order to protect the coil. The Freezestat should be wired in series with a 1 kΩ resistor. When the Freezestat opens the circuit between X5 and M on the MicroTech III Main Control Board, the unit will read an open signal and generate an alarm. See Figure 23 if OAER Switch does not exist.

Wiring Water Flow Sensor

The water flow sensor is powered by 24 VAC from transformer T2. Relay R11 closes a set of NO contacts on X5 on Expansion Module A when the water flow sensor detects water flow. See Figure 23.

NOTE: If there is no Water Flow Sensor on the unit, a jumper needs to be wired between X5 and M on the EXP-A to avoid nuisance alarms.

Figure 23:

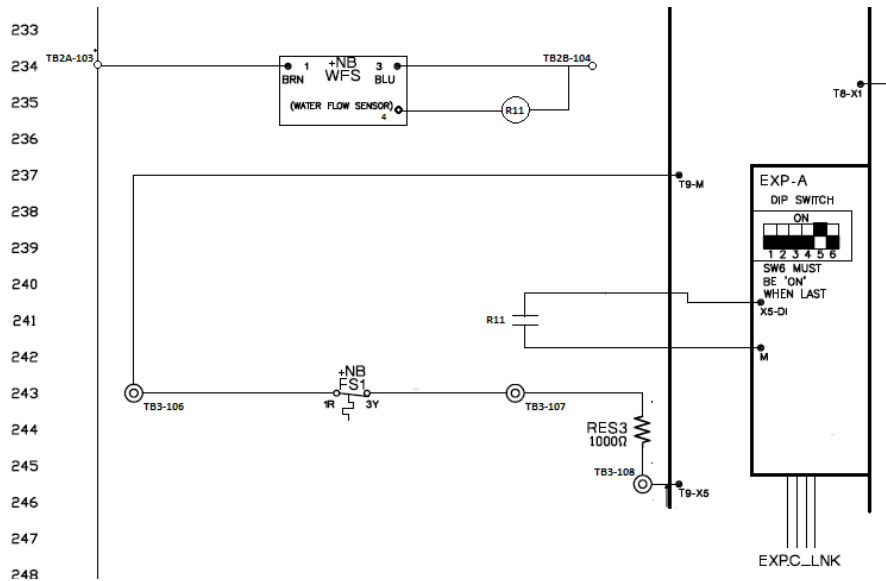

Wiring OAER Switch and Relay

The OAER Switch is a two-position switch that completes a circuit to energize the OAER relay when the return and outside air enthalpy is suitable for economizing. When the NO contacts of the OAER Relay close, this completes a circuit between MCB-X5 and M. A 1500 Ohm resistor is wired in series with the OAER Relay NO contacts. If a Freezestat exists, the OAER Relay and FS1 circuits are wired in parallel to MCB-X5. See Figure 24.

Figure 24:

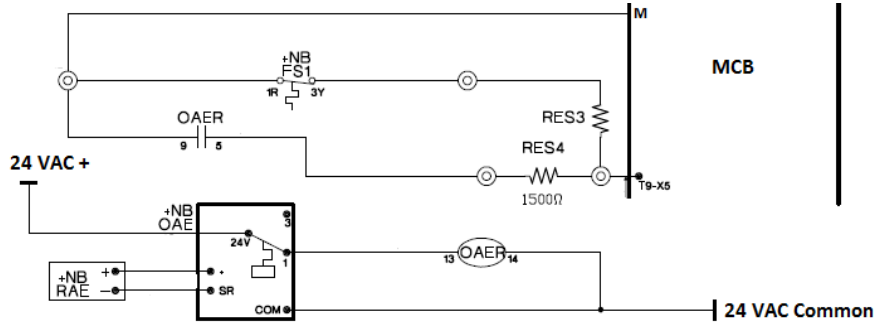

Wiring Modulating Heat Valve

The MicroTech II unit control panel may be equipped with modulating heat. In the MicroTech III controller, modulating heat is controlled through a 2-10VDC signal from the Main Control Board to a modulating valve. Since the MT II controlled unit uses a floating-point controlled heating valve, it either must be reconfigured to accept a 2-10 VDC signal or replaced. The valve is powered with 24 VAC and receives a voltage signal EXPB-X7. See Figure 25.

Figure 25:

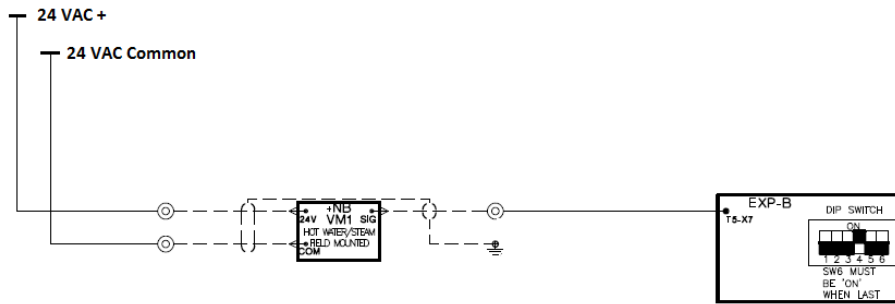

Wiring Staged Heat

The MicroTech II control panel may be equipped with staged heat. Each of the stages are controlled by DO1 through DO6 on Expansion Module B. Only four stages are shown in Figure 26. If there are six stages, wiring will be similar to the first four.

Figure 26:

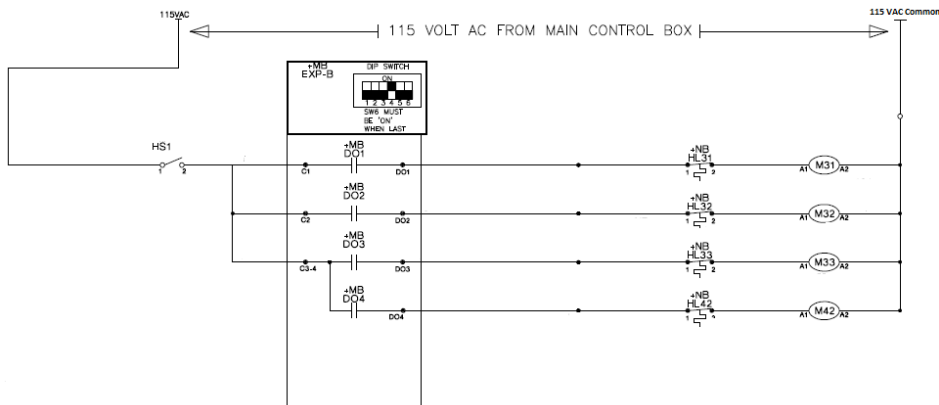

Wiring Waterside Economizer and Water Regulator/Bypass Valves

Follow the directions below when wiring the Waterside Economizer valve actuator (ACT3) and Water Regulator/Bypass valve actuator (ACT4). See Figure 27 for wiring information.

1. Supply 24+ VAC and 24 VAC Common to ACT3 and ACT4 from the respective power terminal blocks.
2. Wire the 2-10 VDC signal from MCB-X7 and connect to terminal 3 on the actuators.
3. Ground the actuators to the proper ground terminal block.

Figure 27:

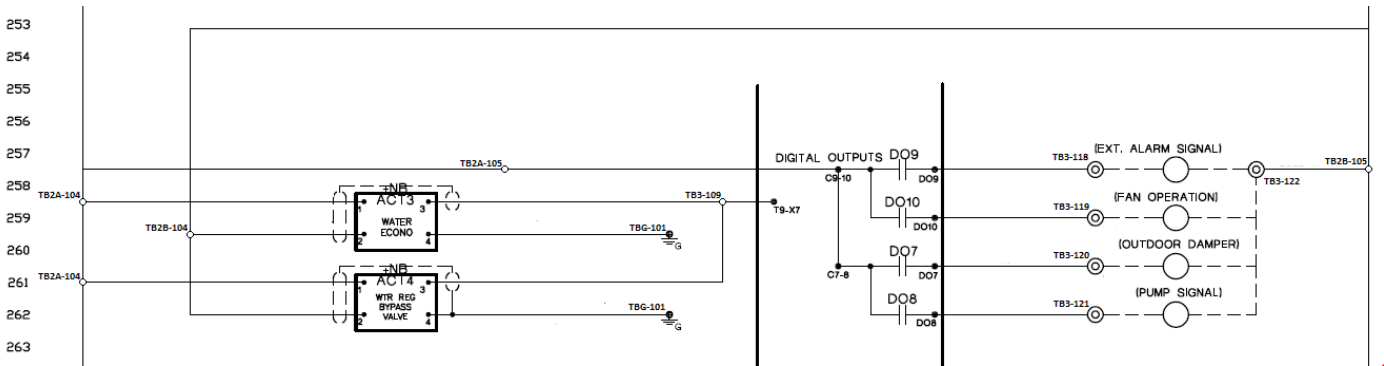

Wiring Supply and Return Fan Enable

The Supply and Return Fan motor contactors need to be wired in series with DO5. See Figure 28.

Figure 28:

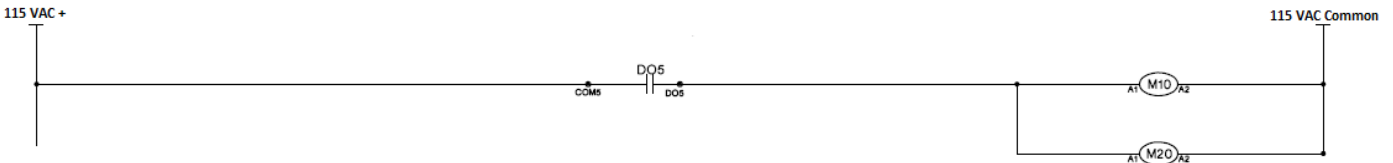

Wiring the Supply Fan and Return/Exhaust Fan Variable Frequency Drives

The Supply and Return/Exhaust Fan Variable Frequency Drives will be connected to the MicroTech III through a pair of Modbus communication wires. A normally closed set of contacts from the R63 relay are wired to the Variable Frequency Drive on terminal DI2.

If the R63 relay contacts are closed, this indicates that the DHL Switch is closed the Variable Frequency Drive is enabled to run. A normally closed set of contacts from a R25 relay can be wired to the Variable Frequency Drive on terminal DI5. The Variable Frequency Drive can be programmed to operate at a constant speed if the R25 contacts are closed.

See an example of the ABB Variable Frequency Drive wiring diagram in Figure 29. Wiring for Schneider and Danfoss Variable Frequency Drives can be found in Appendix G. Refer to manual OM 844 and OM1190 for information on Schneider and ABB Variable Frequency Drives, respectively.

NOTE: Once the Variable Frequency Drive is installed and wired correctly, the parameters for the Variable Frequency Drive must be set. See “Programming the Variable Frequency Drive” in this manual for instructions.

Figure 29:

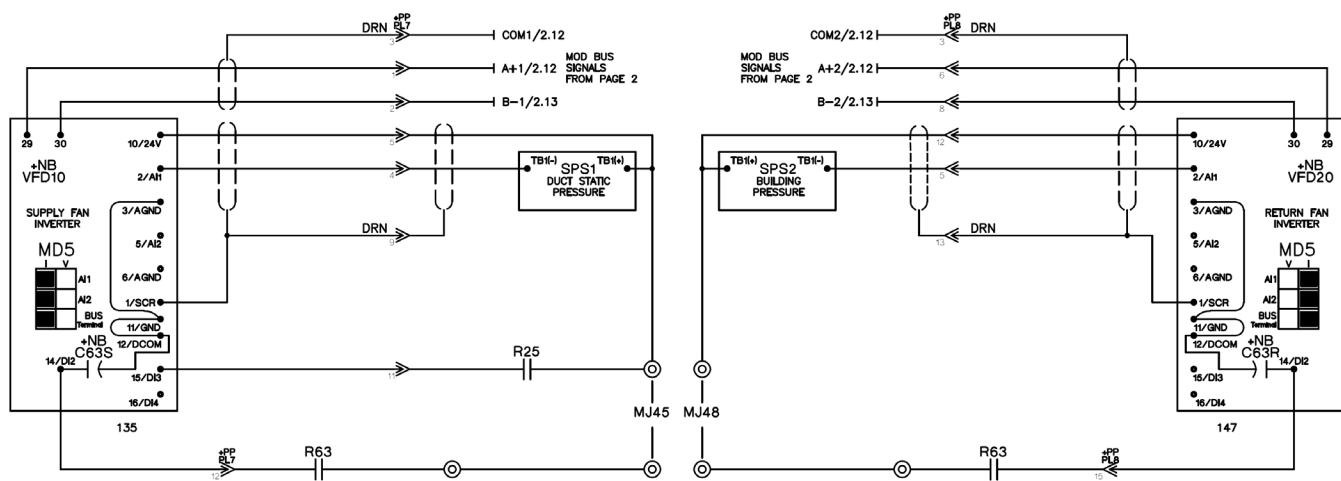

Wiring the Duct Static Pressure Sensor and Building Static Pressure Sensor

If there is an ABB, Schneider or Danfoss Variable Frequency Drive installed, the Duct Static Pressure and Building Static Pressure sensors wire directly to the Variable Frequency Drives.

The 4-20mA output signal from the Duct Static Pressure sensor is wired to the AI1 terminal on the ABB Variable Frequency Drive for Supply Fan. The MicroTech III reads in the Duct Static Pressure transducer signal through Modbus and sends a speed signal to the Variable Frequency Drive in order to maintain the Duct Static Pressure set point. See Figure 29. See Appendix G for Duct Static Pressure wiring on Schneider and Danfoss Variable Frequency Drives.

The 4-20mA output signal from the Building Static Pressure sensor is wired to the AI1 terminal on the ABB Variable Frequency Drive for RF/EF Fan. The MicroTech III reads in the Building Static Pressure sensor signal through Modbus and sends a speed signal to the Variable Frequency Drive in order to maintain the Building Static Pressure set point. See Figure 29. See Appendix G for Building Static Pressure wiring on Schneider and Danfoss Variable Frequency Drives.

Wiring of Network Communication Module

A Network communication module is optional to allow for communication between the unit controller and a Building Management System. There are three Communication Module options: BACnet MS/TP, BACnet IP, and LON (SCC and DAC). Check polarity before connecting the wires, if applicable. Do not wire the third reference conductor or shield to the network communication module. See to Figure 30 for BACnet MS/TP wiring example.

Figure 30:

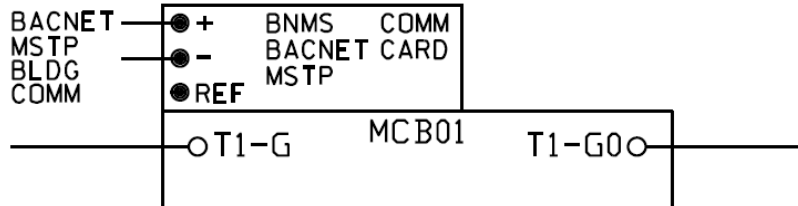

Programming the MicroTech III and Variable Frequency Drive

Programming the MicroTech III

Once the MicroTech III and all the auxiliary electrical devices are installed and wired, the controller will need to be programmed. There are three tasks when programming the MicroTech III controller: Verify and Update Software Code, Set Unit Configuration, and Set Parameters.

Verify and Update Software Code

The unit's software code must be updated to the newest code. See the SIL in Appendix C for instructions on how to upload software code to the MicroTech III controller.

Set Unit Configuration

Each MicroTech III has a unique Unit Configuration that must be set according to the unit's features and capabilities. See IM 919-4 for instructions and unit configuration options.

Set Parameters







After the software code is updated and the unit configuration is set, the parameters on the MicroTech III will need to be set according to the site's specific application.

Programming the Variable Frequency Drive

After the Variable Frequency Drive is installed and wired, the parameters need to be set. See charts in Appendix D through F and set the parameters depending on the type of drive.

Appendix A

Figure 31: Dip Switch Settings

Expansion Board A	Switch #5 in the up position (all others down)	
Expansion Board B	Switch #4 in the up position (all others down)	
Expansion Board C	Switch #4 and #5 in the up position (all others down)	
Expansion Board D	Switch #3 in the up position (all others down)	
Expansion Board E	Switch #3 and #5 in the up position (all others down)	
Dipswitch #6	Switch #6 must be in the up position on the last expansion board in the string regardless whether it is A, B, C, D, or E.	

Appendix B

Figure 32:

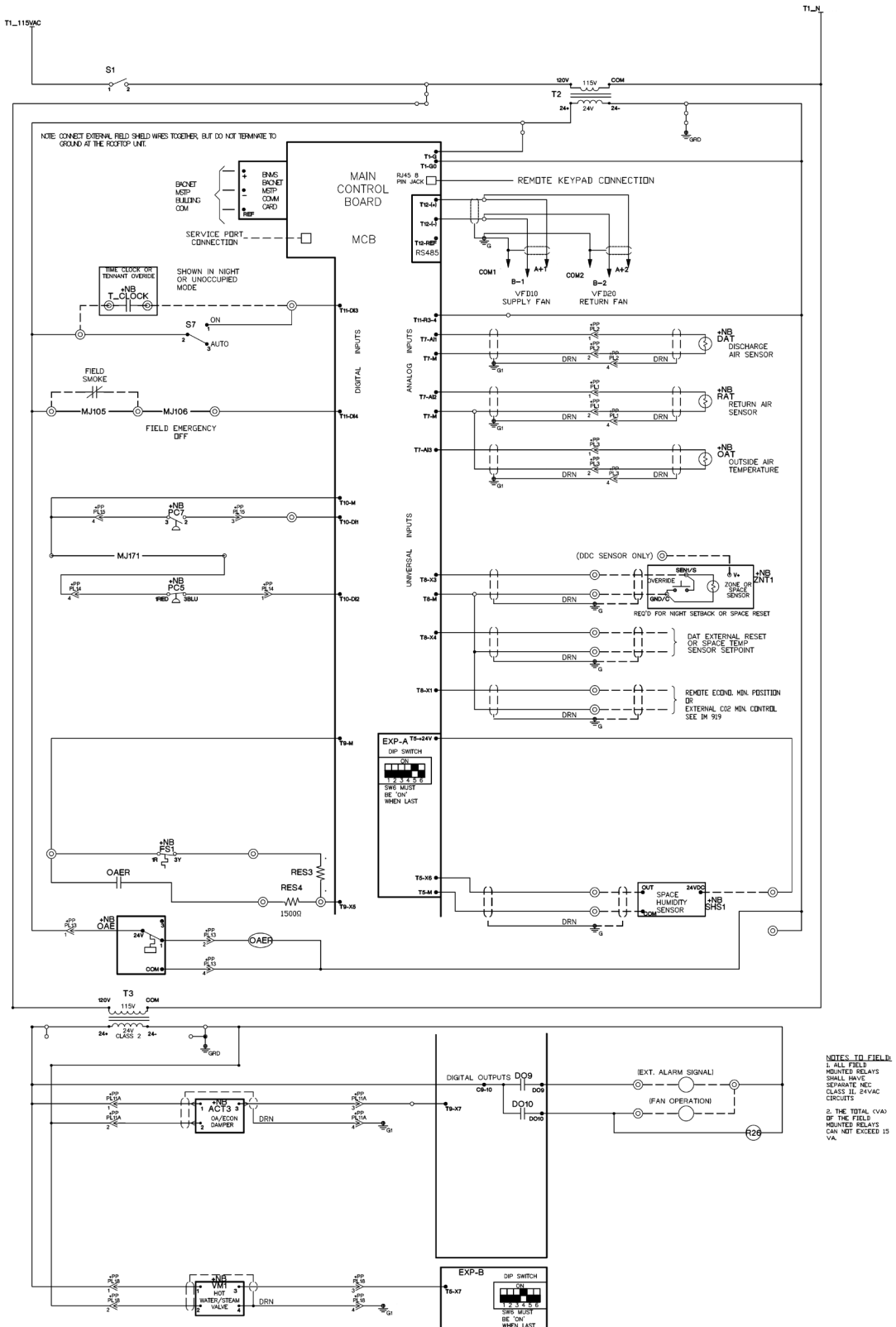
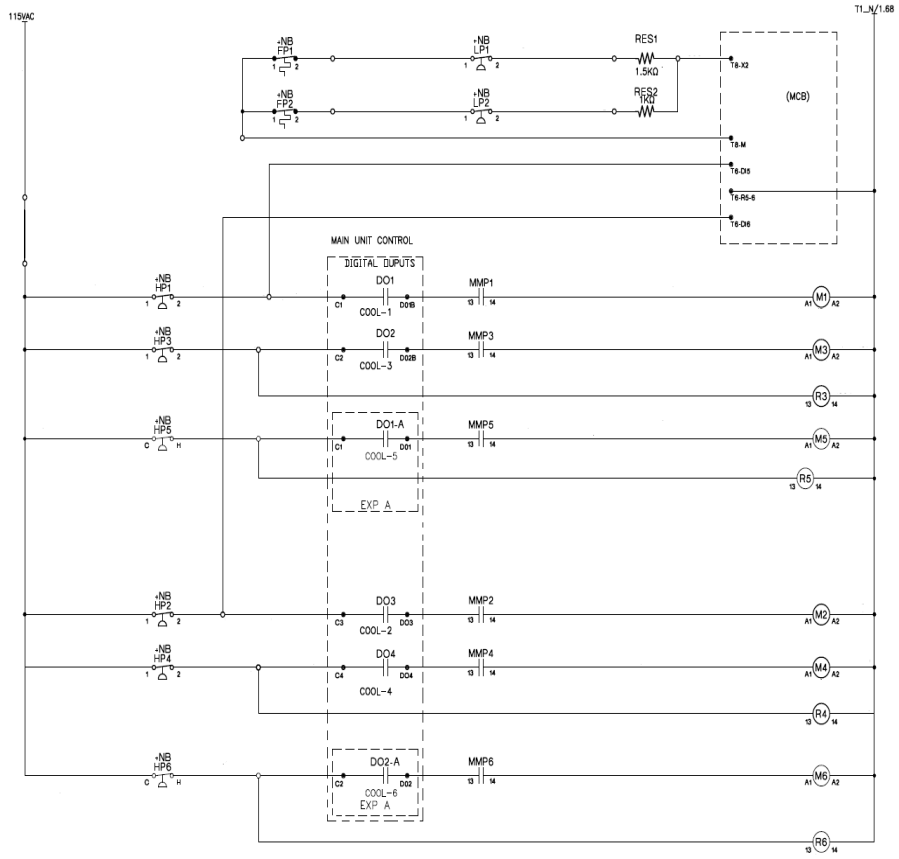

Figure 33:



Appendix C

Figure 34: Code Update SIL



Service Information Letter

Technical Response Center – Applied Air – Plymouth, MN

SIL-ALL-18-001 Date: February 16, 2018
 Originator: Faraz Currimbhoy, Technical Response Center
 Supersedes: SIL-ALL-17-016

Microtech III Controller Software Upgrade Procedures

Use this procedure to upgrade the MicroTech III controller application software and firmware.

Tools Required:

- 3/64" (1 mm) Allen Key
- Flat head screw driver to open control panel door
- SD memory card no larger than 2GB for firmware less than 8.46
- SD memory card no larger than 8GB with a FAT32 file system format for firmware higher than 8.46

Note – If the controller has a BSP version older than 8.40 or the APP version is earlier than 2506017300 contact Daikin Applied Technical Response group for support.

Preparing the SD Card

1. To download the software code files online, navigate to <http://www.daikinapplied.com/search.php>
2. Under the Search Literature section type "250601" under the text search box and click search

3. Scroll down to find the appropriate software version to download and save it to the Desktop.
 - a. 2506017xxx represents Roofpack, Maverick (MPS), and Self-Contained (SWP, SWT) code.
 - b. 2506018xxx represents Rebel (DPS) code

Note: (XXX) changes as the software versions are revised for the respective product lines below.



Figure 34 continued: Code Update SIL

4. Drag the zip file to the freshly formatted SD card and extract it to the root directory of the SD card. See picture below as an example of where the zip file resides on the SD card (E:\) directory.

Note: Every computer will have a different drive letter designation for the SD card. Root directory represents the first location that appears when opening the SD card since the Microtech III controller cannot see files from any folders.

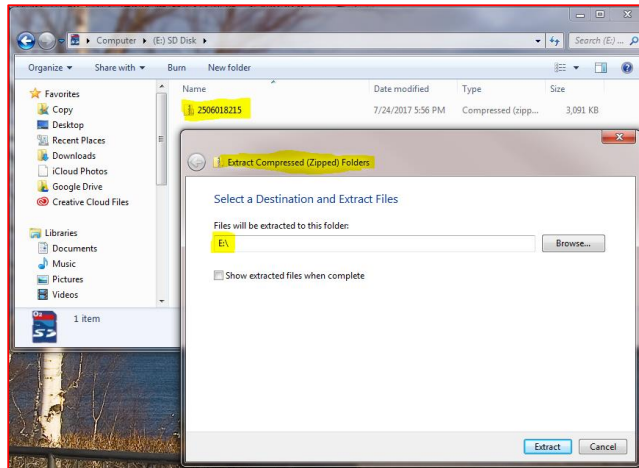

5. Once all the files are extracted there will be a total of 8-9 files appearing on the SD card. Total files counts can change with new software revisions. The list below show critical files needed for a software download.

- HMI.ucf • MBRT.ucf • OBH.ucf • POL687.ucf • POL687.hex (omitted after 513 and 214 codes)

Complete list of files including all critical ones shown below

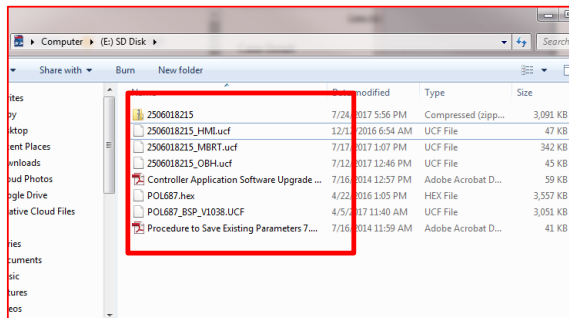

6. This completes preparing the SD card for the download process and should be now taken to the Microtech controller.

Saving Parameters to an SD Card

Note: DO NOT save parameters if the controller experienced a glitch in its operation and skip to the “Download Software to the Controller” section.

1. Enter the level 2 password.
2. From the Main Menu, **set the Control Mode to Off.**
3. Insert the SD memory card into the controller’s memory card slot. The label on the card should be facing to the rear, toward the controller.

Figure 34 continued: Code Update SIL

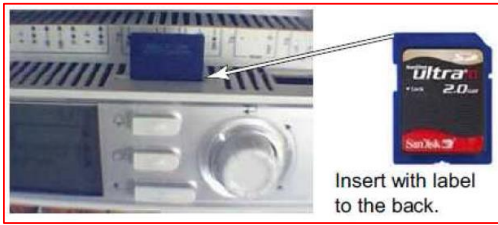

4. Save the existing configuration and parameters to the memory card.
 - a. From the Main Menu select Service Menus then Save/Restore Settings.
 - b. Set SaveToCard option to "Yes" and press the Enter button. Wait till "Yes" reverts to "No"

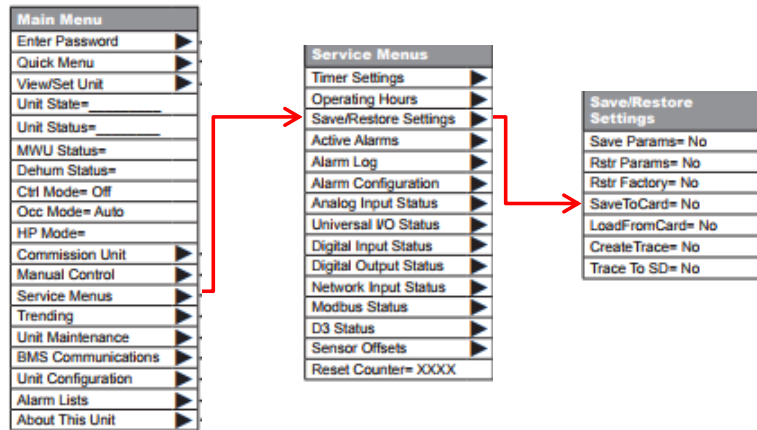

5. Remove the SD card from the controller and inserting the SD card into the Laptop.
6. Verify 2 parameter files (Param.bin & Param.ucf) saved and their file sizes are larger than 100 KB
7. If the param file sizes are less than 100 KB then repeat step 4

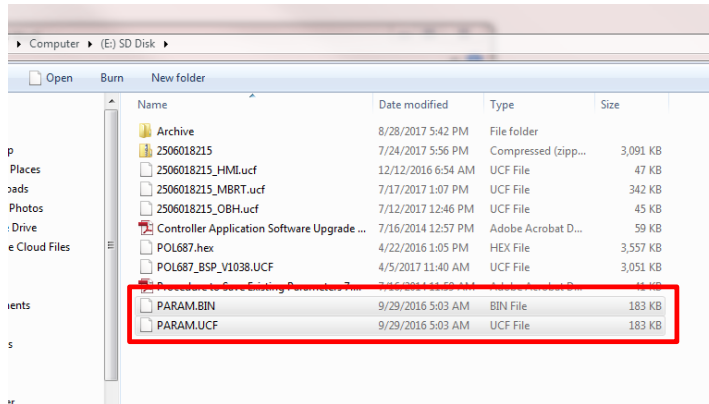

8. If the files are not saving to the existing SD card then check the SD card lock or try a different SD card

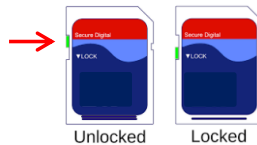

9. This completes saving parameters to the SD card

Figure 34 continued: Code Update SIL

Downloading Software to the Controller

1. Power the controller off and wait 15 seconds
2. Make sure that all communication modules that need to be updated are connected.
3. Insert the end of a 3/64" Allen Key or other similar tool in the service port on the controller and hold the service button depressed. (The service button will "click" once depressed).

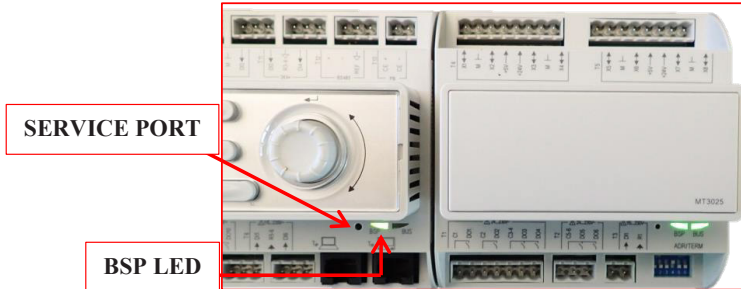

4. While holding the service button depressed, apply power to the controller.
5. Continue depressing the service button and observe the BSP LED begins to flash between red and green.
6. Release the service button after the flashing red/green sequence lasts for 3 or more seconds.
7. When the BSP LED's has stopped flashing between red and green check if the BSP LED is either off or amber. If off then repeat the download process again.
 - a. **Note:** If a BMS communication module is connected to the controller, wait for the controller to automatically reset (approximately 30 seconds) before proceeding to the next step.
 - b. **Note:** Updating from version 8.xx BSP to 10.xx BSP firmware will require repeating the download process twice. During some software downloads, the controller display may flash blue.
8. Cycle power to the controller after a solid amber BSP LED is present.
9. From the Main Menu scroll down to About this AHU and observe the APP version shows the same value as the zip file originally downloaded (2506017xxx or 8xxx).

Restoring Parameters to the Controller

1. Make sure the SD memory card is still within the controller's memory card slot.
2. Enter the Level 2 Password.
3. From the Main Menu select Service Menus then Save/Restore Settings.
4. Set the LoadFromCard parameter to Yes, and press the enter button.
 - a. The controller will reset but may perform an additional reset if a communication module is installed.
 - b. Wait 10 seconds after the main menu appears before proceeding

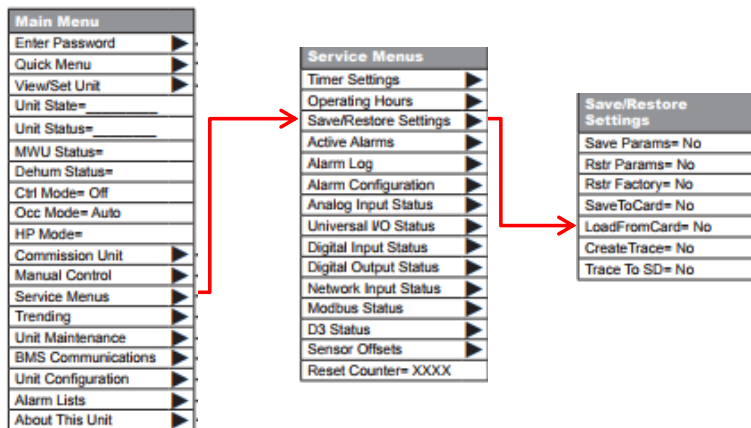
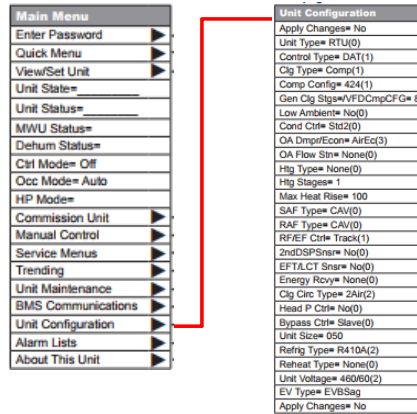

Figure 34 continued: Code Update SIL

5. From the Main Menu scroll down to About this AHU and observe the APP version has no square bracket “...]” at the end. If a square bracket appears then the parameter restore process failed and needs to be repeated.
6. Once the restore process is complete, remove the SD memory card by momentarily pushing it in and releasing to retract.
7. This completes the parameter restore from SD card process

Manually Programming the Unit Configuration

1. If a Save and Restore was not performed then setup the unit per the software configuration sticker installed on the unit door.
 - a. Description of each configurator value is shown under the “Unit Configuration Menu” list below. OM 920 also contains the unit configuration menu.
2. Enter the Level 2 Password.
3. From the Main Menu select Unit Configuration.
4. Scroll through each option within the Unit Configuration menu, changing any parameters not matching the software configuration sticker on the door.



5. Once all the values under the Unit Configuration menu are confirmed, set the Apply Changes parameter to Yes and press the enter button.
6. The controller will perform an automatic reset
7. If the controller did not reset then verify the APP version for an error as mentioned under the “Restore parameters to the controller” section, step 4.
8. This completes the download and programming process.
9. Proceed with setting up individual setting to commission the unit as required for the application.

Figure 34 continued: Code Update SIL

UNIT CONFIGURATION

Configuration Code Position	Description	Values (Default in Bold)	Special Condition	RTU	MPS	DPS	DPS_H	SCU
1	Unit Type	0=Applied Rooftop (RTU) 1=Self-Contained (SCU) 2=Commercial Rooftop (MPS) 3=Rebel Cool Only (DPS/DAH) 4=Rebel Heat Pump (DPS_H)		•	•	•	•	•
2	Control Type	0=Zone Control 1=DAT Control 2=1ZoneVAV		•	•	•	•	•
3	Cooling Type	0 = None 1=Standard Compressorized Clg 2=Chilled Water 3=F&BP 4=Variable Comp Circuit 1 5=Variable Comp Circuit 2 6=VRV 7=NA 8=NA 9=Digital Comp 1 Circuit 10=Digital Comp 2 Circuits		•	•	•	•	•
4	Compressorized Cooling Configuration	0=None 1=Generic Condenser 2=2Cmp/2Circ/3Stg 3=3Cmp/2Circ/4StgorVar (Var used for initial MPS026, 030&035 release) 4=2Cmp/2Circ/2or6StgorVar (6 stg if 7=2,3,4or5) 5=3Cmp/3Circ/3Stg_NoWRV 6=3Cmp/3Circ/3Stg_WRV 7=4Cmp/2Circ/4StgorVar 8=4Cmp/4Circ/4Stg_NoWRV 9=4Cmp/4Circ/4Stg_WRV A=6Cmp/2Circ/6StgorVar B=6Cmp/6Circ/6Stg_NoWRV C=6Cmp/6Circ/6Stg_WRV D=3Cmp/2Circ/5StgorVar E=4Cmp/2Circ/5or8StgorVar (Var used for initial MPS040) (8 stg if 7=2,3,4or5) F=8Cmp/4Circ/8Stg G=8Cmp/8Circ/8Stg H=6Cmp/3Circ/6Stg I=Not Used J=3 Cmp/3Circ/4Stg K=Spare L=1Var/1Circ M=Var/1STD/1Circ		•	•	•	•	•
5	Generic Condenser Stages	1 – 8 Stages (default = 8)		•	• (if 4=4, 5or 6)	• (if 4=4, 5or 6)		
6	Low Ambient	0 = No 1 = Yes	This position currently has no effect on unit operation.					
7	Condenser Control	0=Std Method 1 1=Std Method 2 2=Evap ABB 3=Evap MD2		•	•	•	•	

Figure 34 continued: Code Update SIL

		4=Evap MD3 5=Evap DF 6=Not Used 7=EBM 8=INV 9=INV w/MicroC OA Coil						
8	Damper Type	0=None 1=Single Position 30% 2=Single Position 100% 3=Economizer Airside 4=Economizer Waterside 5=100%OA_D3 6=AirEcon_D3 7=30%_D3 8=EconoAirsideFDD 9=EconFDD3	Values 1, 2, 5 & 7 only apply if Position 1 = 0 (RTU), 2 (MPS), 3 or 4 (DPS) Value 4 only applies if Position 1 = 1 (SCU)	•	•	•	•	•
9	OA Flow Station	0=None 1=DF_015-030 (800) 2=DF_036-042 (802) 3=DF_045-075 (047) 4=DF_080-135 (077) 5=Generic Flow Station 6=Generic Flow Station w/CO2		•	•	•	•	•
10	Heating Type	0=None 1=F&BP Control 2=Staged 3=Modulated Gas, 3-1 4=Modulated Gas 20-1 5=Steam or Hot Water 6=SCR Electric 7=MPSLoGas 8=MPSHiGas		•	•	•	•	•
11	Max Heating Stages	1-8 Stages (Default = 1)		•	•	•	•	•
12, 13, 14	Max Heat Rise	Three Digits (Default = 100)		•	•	•	•	•
15	Supply Fan Type	0=Constant Volume 1=VFD/ABB_BD 2=VFD/DF_BD 3=VFD/MD2_BD 4=VFD/MD3_BD 5=VFD/MD6_BD 6=EBMVAV_DD 7=EBMCAV_DD 8=ABBVAV_DD 9=ABBCAV_DD		•	•	•	•	•
16	Return Fan Type	0=CAV 1=RF_EF VFD/ABB 2=RF_EF VFD/DF 3=RF_EF VFD/MD2 4=RF_EF VFD/MD3 5=RF_EF VFD/MD6 6=PrpEx VFD/ABB 7=PrpEx VFD/DF 8=PrpEx VFD/MD2 9=PrpEx VFD/MD3 A=PrpEx VFD/MD6 B=None C=1StageExh D=2StageExh E=3StageExh F=EBMVAV_DD G=EBMCAV_DD H=ABBVAV_DD I=Not Used J=ABBCAV_DD		•	•	•	•	

Figure 34 continued: Code Update SIL

17	Return/Exhaust Fan Capacity Control Method	0=None 1=Tracking 2=Building Pressure 3=Speed 4=OADamper		•	•	•	•	
18	Second Duct Pressure Sensor	0=No 1= Yes		•				•
19	Entering Fan Temp Sensor	0=No 1=Yes		•	•	•	•	
20	Energy Recovery	0=None 1=ConstSpdWhl/NoRH 2=VarSpdWhl/Danfoss 3=VarSpdWhl/MD2 4=VarSpdWhl/MD3 5=VarSpdWhl/ABB 6=ConstSpdWhl/wRH		•	•	•	•	
21	Cooling Circuit Type	0=Individual 1=2,3 or 4 Circ. Water Condenser 2=2 Circ. Air Condenser	Values 0 and 1 are valid only when Position 1 = 1 (SCU)	•	•			•
22	Head Pressure Control	0=No 1=Yes	This position is valid only when Position 1 = 1 (SCU).					•
23	Bypass Valve Control	0=Slave 1=Bypass	This position is valid only when Position 1 = 1 (SCU).					•
24, 25, 26	Unit Size	Three digits (default 050)		•	•	•	•	•
27	Refrigerant Type	0=R22 1=R407C 2=R410A		•	•	•	•	•
28	Reheat Type	0=None 1=StgHG 2=ModHG 3=StdHtRht 4=ModLSC 5=ModHG&LSC		•	•	•	•	
29	Unit Voltage	0=208/60Hz 1=230/60Hz 2=460/60Hz 3=575/60Hz 4=208/50Hz 5=230/50Hz 6=460/50Hz 7=575/50Hz		•	•	•	•	•
30	EVType	0=None 1=EVB_Sag 2=EVB_DF 3=MTIII_Sag 4=MTIII_DF 5=MTIII_Sag_DF 6=MTIII_DF_Sag 7=MTIII_DF_C				•	•	

Figure 34 continued: Code Update SIL

**For questions about the procedure please contact the Technical Response team at:
TechresponseAAH@daikinapplied.com or 844-521-3928**

Appendix D

Table 2: ACS320 and ACH550 Parameters

MD4 Parameters		Unit	RoofPak & Self C	DPS 016-028 MPS 015-050	DPS 016-028 MPS 015-050	RPS / RDT / RCS	RPE / RDE	RoofPak	Maverick II & Rebel
#	Name		SAF, RAF & EAF	SAF	EAF	Condenser Fan	Condenser Fan	Energy Rec Wheel	Energy Rec Wheel
9802	COMM PROT SEL		STD MODBUS	STD MODBUS	STD MODBUS	Not Selected	STD MODBUS	STD MODBUS	STD MODBUS
9901	LANGUAGE		ENGLISH	ENGLISH	ENGLISH	ENGLISH	ENGLISH	ENGLISH	ENGLISH
9902	APPLIC MARCO		HVAC DEFAULT	HVAC DEFAULT	HVAC DEFAULT	HVAC DEFAULT	HVAC DEFAULT	HVAC DEFAULT	HVAC DEFAULT
9905	MOTOR NOM VOLT	V	460	460	460	460	460	460	460
9906	MOTOR NOM CURR	A	35	24	4	2.6	11.2	1.1	0.5
9907	MOTOR NOM FREQ	Hz	60	60	60	60	60	60	60
9908	MOTOR NOM SPEED	rpm	1775	1775	1140	1142	1775	1775	1775
9909	MOTOR NOM POWER	hp	30	20	3	1.5	5	1	0.2
1001	EXT1 COMMANDS		COMM	COMM	COMM	DI1	COMM	COMM	COMM
1102	EXT1/EXT2 SEL		EXT1	EXT1	EXT1	EXT1	EXT1	EXT1	EXT1
1103	REF1 SELECT		COMM	COMM	COMM	AI 1	COMM	COMM	COMM
1104	REF1 MIN	Hz	0	0	0	24	0	0	0
1105	REF1 MAX	Hz	60	60	60	60	60	60	60
1106	REF2 SELECT		KEYPAD	KEYPAD	KEYPAD	KEYPAD	KEYPAD	KEYPAD	KEYPAD
1201	CONST SPEED SEL		NOT SEL	NOT SEL	NOT SEL	DI 3	NOT SEL	NOT SEL	NOT SEL
1601	RUN ENABLE		COMM	COMM	COMM	DI 2	COMM	COMM	COMM
1604	FAULT RESET SEL		COMM	COMM	COMM	KEYPAD	COMM	COMM	COMM
1607	PARAM SAVE		DONE	DONE	DONE	DONE	DONE	DONE	DONE
1608	START ENABLE 1		COMM	COMM	COMM	DI 4	NOT SEL	COMM	COMM
1611	PARAMETER VIEW		LONG VIEW	LONG VIEW	LONG VIEW	LONG VIEW	LONG VIEW	LONG VIEW	LONG VIEW
2101	START FUNCTION		SCAN START	SCAN START	SCAN START	SCAN START	SCAN START	SCAN START	SCAN START
2202	ACCELER TIME 1	s	60	60	60	10	5	60	60
2203	DECELER TIME 1	s	60	60	60	10	30	60	60
2605	U/F RATIO		LINEAR	LINEAR	LINEAR	LINEAR	LINEAR	LINEAR	LINEAR
3003	EXTERNAL FAULT 1		DI 2(INV)	NOT SEL	NOT SEL	NOT SEL	NOT SEL	NOT SEL	NOT SEL
3009	BREAK POINT FREQ	Hz	45	45	45	45	45	45	45
3101	NUMBER TRIALS		5	5	5	5	5	5	5
3103	DELAY TIME	s	3	3	3	3	3	3	3
3104	AR OVERCURRENT		ENABLE	ENABLE	ENABLE	DISABLE	ENABLE	ENABLE	ENABLE
3404	OUTPUT1 DSP FORM		DIRECT	DIRECT	DIRECT	+0.0	+0.0	DIRECT	DIRECT
3405	OUTPUT1 UNIT		%	Hz	Hz	% SP	Hz	Hz	Hz
3415	SIGNAL3 PARAM		AI 1	SPEED	SPEED	AI 1	SPEED	SPEED	SPEED
3418	OUTPUT3 DSP FORM		+0.0	DIRECT	DIRECT	+0.0	DIRECT	DIRECT	DIRECT
3421	OUTPUT3 MAX		44ma	1800 rpm	1800 rpm	10v	1800rpm	1800 rpm	1800 rpm
4201	GAIN		The Daikin software version [will grow over time]						
4202	INTEGRATION TIME	s	279	252	228	106	103	202	204
5302	EFB STATION ID		SAF=1,R/EAF=2	1	2	1	4	3	3
5303	EFB BAUD RATE		192	192	192	96	192	192	192
5304	EFB PARITY		8 NONE 2	8 NONE 2	8 NONE 2	Values Vary	8 NONE 2	8 NONE 2	8 NONE 2
5306	EFB OK MESSAGES		Usually a big number that continues to grow						
5307	EFB CRC ERRORS		0	0	0	0	0	0	0
5308	EFB UART ERRORS		Should be a small number that rarely grows unless a MicroTech III communication problem occurred						
5309	EFB STATUS		ON-LINE	ON-LINE	ON-LINE	ON-LINE	ON-LINE	ON-LINE	ON-LINE
8120	INTERLOCKS		NOT SEL	NOT SEL	NOT SEL	DI 4	NOT SEL	NOT SEL	NOT SEL
1002	EXT2 COMMANDS		NOT SEL	NOT SEL	NOT SEL	DI 1	NOT SEL	NOT SEL	NOT SEL
1301	MINIMUM AI1	%	MicroTech III limits minimum speed to 20 hz			10	MicroTech III limits minimum speed to 20 hz		
1302	MAXIMUM AI1	%	MicroTech III limits maximum speed to 60 hz			50	MicroTech III limits maximum speed to 60 hz		
1303	FILTER AI1	s				0.1			
3502	INPUT SELECTION					AI 1			
4210	SET POINT SEL					AI 1			
1202	CONST SPEED 1	Hz				60			
1401	RELAY OUTPUT 1					FAULT			

Vary depending on motor nameplate voltage and hp
 These values vary depending on the application
 Not important, will be HVAC default values

Table 3: ACH580 Parameters

MD5 Parameters				
	#	Name	Unit	VALUE
GROUP 96 - SYSTEM				
	96.04	MACRO SELECT		HVAC DEFAULT
GROUP 99 - MOTOR DATA				
	99.06	MOTOR NOM CURR	A	Motor Specific
	99.07	MOTOR NOM VOLT	V	Motor Specific
	99.09	MOTOR NOM SPEED	RPM	Motor Specific
	99.10	MOTOR NOM POWER	HP	Motor Specific
GROUP 12 - STANDARD AI				
	12.15	AI1 UNIT SELECTION		MA
	12.19	AI1 SCALED AT AI1 MIN		200
	12.20	AI1 SCALED AT AI1 MAX		1000
	12.25	AI2 UNIT SELECTION		MA
	12.29	AI2 SCALED AT AI2 MIN		200
	12.30	AI2 SCALED AT AI2 MAX		1000
GROUP 20 - START/STOP/DIR				
	20.01	EXT1 COMMANDS		EMBEDDED FIELDBUS
	20.21	DIRECTION		FORWARD
	20.41	START INTERLOCK 1		NOT USED
	20.42	START INTERLOCK 2		NOT USED
GROUP 22 - REFERENCE SELECT				
	22.11	EXT SPEED REF1		EFB REF1
	22.22	CONSTANT SPEED SEL1		ALWAYS OFF
	22.41	SPEED REF SAFE	RPM	0
GROUP 28 - FREQUENCY REFERENCE CHAIN				
	28.11	EXT1 FREQUENCY REF1		EFB REF1
	28.22	CONSTANT FREQ SEL1		ALWAYS OFF
	28.41	FREQUENCY REF SAFE	Hz	0
	28.72	FREQ ACCELERATION TIME 1	S	60
	28.73	FREQ DECELERATION TIME 1	S	60
GROUP 31 - FAULT FUNCTIONS				
	31.01	External Event 1 Source		DI2
	31.14	NUMBER OF TRIALS		5
	31.16	DELAY TIME	S	3
	31.27	STALL FREQUENCY LIMIT	Hz	45
	31.25	AR OVERCURRENT		ENABLE
GROUP 46 - MONITOR / SCALING SETTINGS				
	46.02	FREQUENCY SCALING		1000
GROUP 58 - EMBEDDED FILEDBUS				
	58.01	PROTOCOL ENABLE		MODBUS RTU
	58.03	NODE ADDRESS		1 (SAF) or 2 (RF/EF)
	58.04	BAUD RATE		19.2 KBPS
	58.05	PARITY		8 NONE 2
	58.14	COMMUNICATION LOSS ACTION		SPEED REF SAFE
	58.15	COMMUNICATION LOSS MODE		CW/REF1/REF2
	58.16	COMMUNICATION LOSS TIME	S	25.0 S
	58.33	ADDRESSING MODE		MODE0
	58.06	Communication Control		Enabled
GROUP 71 - EXTERNAL PID1				
	71.32	GAIN		1.00
	71.33	INTEGRATION TIME	S	2155
GROUP 97 - MOTOR CONTROL				
	97.20	U/F RATIO		LINEAR

Appendix E

Figure 35: Parameters

Parameter	On the PC exactly...	Appears as...	Keypad Menu-then drop	Keypad Noun	Keypad Value	Comments
0-03	Regional Settings	North America	start at 0-0* Basic Settings	0-03 Regional Settings	[1] North America	Required change to allow many 60 Hz settings
1-21	Motor Power [HP]	enter dataplate value	start at 1-** Load and Motor	1-21 Motor Power [HP]	enter dataplate value	FACTORY ENTER
1-22	Motor Voltage	enter dataplate value	start at 1-** Load and Motor	1-22 Motor Voltage	enter dataplate value	FACTORY ENTER
1-23	Motor Frequency	60Hz	start at 1-** Load and Motor	1-23 Motor Frequency	60Hz	Almost always 60 Hz
1-25	Motor Nominal Speed	1760	start at 1-** Load and Motor	1-25 Motor Nominal Speed	1760	1760 is close, motor nameplate may be different.
1-73	Flying Start	Enabled	start at 1-** Load and Motor	1-73 Flying Start	[1] Enabled	
3-02	Minimum Reference	00.00	start at 3-0* Reference Limits	3-02 Minimum Reference	00.000	Modbus comms controls the lowest motor speed.
3-04	Reference Function	Sum	start at 3-0* Reference Limits	3-04 Reference Function	[0] Sum	Sum of all presets-Writes via modbus to parameter 3-10. Others will be zero.
3-15	Reference 1 Source	No Function	start at 3-1* References	3-15 Reference 1 Source	[0] No function	Duct Static P1: Signal between 53 & 55. Set switch A53 to ON for ma.
3-16	Reference 2 Source	No Function	start at 3-1* References	3-16 Reference 2 Source	[0] No Function	Duct Static P2: Signal between 54 & 55. Set switch A54 to ON for ma.
3-17	Reference 3 Source	No Function	start at 3-1* References	3-17 Reference 3 Source	[0] No Function	
3-41	Ramp 1 Ramp Up Time	60.00	start at 3-4* Ramp 1	3-41 Ramp 1 Ramp Up Time	60.00s	
3-42	Ramp 1 Ramp Down Time	60.00	start at 3-4* Ramp 1	3-42 Ramp 1 Ramp Down Time	60.00s	
5-01	Terminal 27 Mode	Input	start at 5-00 Digital I/O mode	5-01 Terminal 27 mode	[0] Input	Contacts between 27 and 12.
5-02	Terminal 29 Mode	Output	start at 5-00 Digital I/O mode	5-02 Terminal 27 mode	[1] Output	If not [1] then 5-31 is locked-out.
5-12	Terminal 27 Digital Input	External Interlock	start at 5-1* Digital Inputs	5-12 Terminal 27 Digital Input	[7] External Interlock	
5-14	Terminal 32 Digital Input	Fire Mode	start at 5-1* Digital Inputs	5-14 Terminal 32 Digital Input	[37] Fire Mode	
5-15	Terminal 33 Digital input	No Operation	start 5-1* Digital Inputs	5-15 Terminal 33 Digital Input	[0] No Operation	
5-31	Terminal 29 Digital Output	No Operation	start 5-3* Digital Outputs	5-31 Terminal 29 Digital Output	[60] Comparator 0	Must set 5-02 first, then 13-10, 13-11, and 13-12, then 5-31 last.
8-30	Protocol	FC (required for write to drive)	start at 8-3* FC Port Settings	8-30 Protocol	[2] RTU Modbus	Change via keypad, power cycle required. Wired +@#68, -@ #69, Shield at #61
8-31	Address	1 (found at default)	start at 8-3* FC Port Settings	8-31 Address	[1]SAF,[2]RAF,[3]EXH	Change via keypad, power cycle required. Choose MT3 address of VFD to be controlled
8-32	Baud rate	9600 Baud (found at default)	start at 8-3* FC Port Settings	8-32 Baud rate	[3] 19200 Baud	Change via keypad, power cycle required. 19,200 required for MT3 coms
8-33	Parity / Stop Bits	Even Parity, 1 Stop Bit (at default)	start at 8-3* FC Port Settings	8-33 Parity, Stop Bits	[3] No Parity, 2 Stop Bits	Change via keypad, power cycle required. Required for MT3 comms
8-35	Minimum Response Delay	need to enter new value = 100	start at 8-3* FC Port Settings	8-35 Minimum Response Delay	100ms	MT3 best operation this setting
8-50	Protocol	Logic OR (default)	8-50* Digital Bus	8-50 Coasting Select	[3] Logic OR	MT3 best operation this setting
8-53	Start Select	Logic OR (default)	8-50* Digital Bus	8-53 Start Select Logic OR	[3] Logic OR	Modbus OR Input 53
13-10.00	Comparator Operand	Alarm Number	Comparators-1 13-1*	13-10 Comparator Operand	[20] Alarm Number	Set 5-02 first, then 13-10, then 13-11 next
13-11.0	Comparator Operator	(equal)	Comparators-1 13-1*	13-11 Comparator Operator	[1] = (equal)	Set 13-10 first, then 13-11, then 13-12 next
13-12.0	Comparator Value	60.000	Comparators-1 13-1*	13-12 Comparator Value	60.000	Set 13-11 first, then 13-12, then 5-31 last
Switch- TERM.		Set to IN at highest address of 8-31				Set to IN at highest address of 8-31
Switch A53		set to = I			set to = I	Switch is behind keypad.
Switch A54		set to = I			set to = I	Switch is behind keypad.
IMPORTANT NOTES:						
Technical assistance from Danfoss 414-365-8639, cell 414-704-8997; Ken Fonstad or others.						
"Numeric" keypads only display the parameter value as a number, it is not followed by words as the "Graphical" keypad displays.						
Yellow shaded parameters are unique to MT3 controls and MODBUS communications						
Light Green shaded parameters are general in nature, some are FACTORY set from motor dataplate values.						
Danfoss FC102 drives are configured for FC port communications "out of the box". Use a PC and the MCT 10 software which performs a WRITE TO DRIVE that downloads all except the Modbus communications parameters into the drive. Additional instructions are						
Change the Communication parameters 8-30, 8-31, 8-32, & 8-33 with the keypad. Cycle the power.						
If unit will not communicate, FC102 terminals 68 & 69 might be accidentally exchanged.						
Keypad Password access parameters are 0-60, 0-61, 0-65 & 0-66. Full Access is normal. Graphic keypads can "transport" parameters to other drives. Use parameter 0-50 = [2] Copt All From LCP. Use 0-50 = [1] to Copt All To LCP. Numeric keypads cannot do this copy operation..						

P:\Engineering\ENG_data\AFD PARAMETER SOURCE FILES\170632800.xls
MT3 FC102 All Modbus

Appendix F

Figure 36: ATV 212 (MD2) Drive Parameters

PART NUMBER		REV B	PART DESCRIPTION				
170632000			Rooftop - MT3 SAF (set 321) PARAMETERS				
Code	Function Description	Unit	Drive	Voltage	HP	Application	
			ATV21	ALL	ALL	SAF/RAF, RT/SC	Logical Address
			Min. Value	Max. Value	Default Value	New Value	
AU1	Automatic acceleration/deceleration	1	0	2	1	0	0
AU4	Automatic function setting	1	0	4	0	1	40
CMOd	Command mode selection	1	0	2	0	2	3
FMOd	Frequency setting mode selection 1	1	1	5	1	4	4
FMSL	Meter selection	1	0	19	0		5
FM	Meter adjustment	1	1	1280	145	318	6
tyP	Default setting	1	0	9	0	7	7
Fr	Forward/reverse run selection (Operation panel)	1	0	3	0		8
ACC	Acceleration time 1	0.1sec	0,0	3200,0	10	60	9
DEC	Deceleration time 1	0.1sec	0,0	3200,0	10	60	10
FH	Maximum frequency	0.01Hz	30,00	200,00	50	60	11
UL	Upper limit frequency	0.01Hz	0,50	80,00	50	60	12
LL	Lower limit frequency	0.01Hz	0,00	60,00	0	20	13
vL	Base frequency 1	0.01Hz	25,00	200,00	50	60	14
vLv	Base frequency voltage 1	0.1V	50,0	660,0		McQuay load	409
Pt	V/F control mode selection 1	1	0	6	1		15
vb	Torque boost 1	0.10%	0,0	30,0	5		16
tHr	Motor electronic-thermal protection level 1	1%	10	100	100		600
OLM	Electric-thermal protection characteristic selection	1	0	7	0	1	17
Sr1	Preset-speed operation frequency 1	0.01Hz	0,00	60,00	15		18
Sr2	Preset-speed operation frequency 2	0.01Hz	0,00	60,00	20		19
Sr3	Preset-speed operation frequency 3	0.01Hz	0,00	60,00	25		20
Sr4	Preset-speed operation frequency 4	0.01Hz	0,00	60,00	30		21
Sr5	Preset-speed operation frequency 5	0.01Hz	0,00	60,00	35		22
Sr6	Preset-speed operation frequency 6	0.01Hz	0,00	60,00	40		23
Sr7	Preset-speed operation frequency 7	0.01Hz	0,00	60,00	45		24
F100	Low-speed signal output frequency	0.01Hz	0,00	80,00	0		100
F101	Speed reach setting frequency	0.01Hz	0,00	80,00	0		101
F102	Speed reach detection band	0.01Hz	0,00	80,00	2.5		102
F108	2nd always-active function selection	1	0	71	0		108
F109	Analog/contact input function selection (VIA/VIB)	1	0	2	0		109
F110	Always-active function selection	1	0	71	1		110
F111	Input terminal selection1 (F)	1	0	71	2	45	111
F112	Input terminal selection 2 (R)	1	0	71	6	0	112
F113	Input terminal selection 3 (RST)	1	0	71	10		113
F118	Input terminal selection 8 (VIA)	1	0	71	7		118
F130	Output terminal selection 1A (RY-RC)	1	0	255	4	14	130
F132	Output terminal selection 3 (FL)	1	0	255	11		132
F137	Output terminal selection 1B (RY-RC)	1	0	255	255		137
F139	Output terminal logic selection (RY-RC/OUT-NO)	1	0	1	0		139
F167	Frequency command agreement detection range	0.01Hz	0,00	80,00	2.5		167
F170	Base frequency 2	0.01Hz	25,00	200,00	50	60	170
F171	Base frequency voltage 2	0.1V	50,0	660,0			171
F172	Torque boost 2	0.10%	0,0	30,0	5		172
F173	Motor electronic-thermal protection level 2	1%	10	100	100		173
F185	Stall prevention level 2	1%	10	111	110		185
F200	Frequency priority selection	1	0	1	0		200
F201	VIA input point 1 setting	1%	0	100	0		201
F202	VIA input point 1 frequency	0.01Hz	0,00	200,00	0		202
F203	VIA input point 2 setting	1%	0	100	100		203
F204	VIA input point 2 frequency	0.01Hz	0,00	200,00	50		204

Figure 36 continued: ATV 212 (MD2) Drive Parameters

PART NUMBER		REV	PART DESCRIPTION				
170632000			Rooftop - MT3 SAF (set 321) PARAMETERS				
Code	Function Description	Unit	Drive	Voltage	HP	Application	
			ATV21	ALL	ALL	SAF/RAF, RT/SC	Logical Address
			Min. Value	Max. Value	Default Value	New Value	
F207	Frequency setting mode selection 2	1	1	5	2		207
F210	VIB input point 1 setting	1%	0	100	0		210
F211	VIB input point 1 frequency	0.01Hz	0,00	200,00	0		211
F212	VIB input point 2 setting	1%	0	100	100		212
F213	VIB input point 2 frequency	0.01Hz	0,00	200,00	50		213
F240	Starting frequency setting	0.01Hz	0,50	10,00	0.5		240
F241	Operation starting frequency	0.01Hz	0,00	80,00	0		241
F242	Operation starting frequency hysteresis	0.01Hz	0,00	80,00	0		242
F250	DC braking starting frequency	0.01Hz	0,00	80,00	0		250
F251	DC braking current	1%	0	100	50		251
F252	DC braking time	0.1sec	0,0	20,0	1		252
F256	Time limit for lower-limit frequency operation	0.1sec	0,0	600,0	0		256
F264	Input from external contacts-UP response time	0.1sec	0,0	10,0	0.1		264
F265	Input from external contacts-UP frequency step width	0.01Hz	0,00	80,00	0.1		265
F266	Input from external contacts-DOWN response time	0.1sec	0,0	10,0	0.1		266
F267	Input from external contacts-DOWN freq step width	0.01Hz	0,00	80,00	0.1		267
F268	Initial value of UP/DOWN frequency	0.01Hz	0,00	60,00	0	20	268
F269	Saving of changed value of UP/DOWN frequency	1	0	1	1		269
F270	Jump frequency 1	0.01Hz	0,00	80,00	0		270
F271	Jump width 1	0.01Hz	0,00	30,00	0		271
F272	Jump frequency 2	0.01Hz	0,00	80,00	0		272
F273	Jump width 2	0.01Hz	0,00	30,00	0		273
F274	Jump frequency 3	0.01Hz	0,00	80,00	0		274
F275	Jump width 3	0.01Hz	0,00	30,00	0		275
F294	Preset-speed operation frequency 15	0.01Hz	0,00	60,00	50		294
F295	Selection of bumpless	1	0	1	1		295
F300	PWM carrier frequency	0.1kHz	6,0	16,0			300
F301	Auto-restart control selection	1	0	4	3		301
F302	Regeneration power ride-through control (Deceleration stop)	1	0	2	0		302
F303	Retry selection (number of times)	1	0	10	3	5	303
F305	Over-voltage limit operation (Slowdown stop mode selection)	1	0	3	2		305
F307	Supply voltage correction (limitation of output voltage)	1	0	3	3		307
F311	Reverse-run prohibition	1	0	2	1		311
F312	Random mode	1	0	1	0		312
F316	Carrier frequency control mode selection	1	0	3	1		316
F320	Drooping gain	1%	0	100	0		320
F323	Drooping insensitive torque band	1%	0	100	10		323
F359	PID control waiting time	1sec	0	2400	0		359
F360	PID control	1	0	2	0		360
F362	Proportional gain	0.01	0,01	100,00	0.3		362
F363	Integral gain	0.01	0,01	100,00	0.2		363
F366	Differential gain	0.01	0,00	2,55	0		366
F400	Auto-tuning	1	0	2	0		400
F401	Slip frequency gain	1%	0	150	50		401
F402	Motor constant #1 (primary resistance)	0.10%	0,0	30,0			402
F415	Motor rated current	0.1A	0,1	200,0			415
F416	Motor no-load current	1%	10	100			416
F417	Motor rated speed	1min-1	100	15000			417
F418	Speed control response coefficient	1	1	150	40		418
F419	Speed control stability coefficient	1	1	100	20		419
F470	VIA bias	1	0	255	128		470

Figure 36 continued: ATV 212 (MD2) Drive Parameters

PART NUMBER		REV B	PART DESCRIPTION				
170632000			Roof-top - MT3 SAF (set 321) PARAMETERS				
Code	Function Description	Unit	Drive	Voltage	HP	Application	
			ATV21	ALL	ALL	SAF/RAF, RT/SC	Logical Address
			Min. Value	Max. Value	Default Value	New Value	
F471	VIA gain	1	0	255	148		471
F472	VIB bias	1	0	255	128		472
F473	VIB gain	1	0	255	148		473
F480	Exciting strengthening coefficient	1%	100	130	100		480
F481	Factory adjustment 1	1	0	9999	0		481
F482	Factory adjustment2	1	0	9999	442		482
F483	Factory adjustment3	0.1	0,0	300,0	100		483
F485	Stall cooperation gain at field weakening zone 1	1	10	250	100		485
F492	Stall cooperation gain at field weakening zone 2	1	50	150	100		492
F494	Motor adjustment factor	1	0	200	70		494
F495	Maximum voltage adjustment factor	1%	90	120	104		495
F496	Carrier change adjustment factor	0.1kHz	0,1	14,0	14		496
F500	Acceleration time 2	0.1sec	0,0	3200,0	20		500
F501	Deceleration time 2	0.1sec	0,0	3200,0	20		501
F502	Acceleration/deceleration 1 pattern	1	0	2	0		502
F503	Acceleration/deceleration 2 pattern	1	0	2	0		503
F504	Acceleration/deceleration selection (1/2/3)	1	1	2	1		504
F505	Acceleration/deceleration 1 and 2 switching frequency	0.01Hz	0,00	60,00	0		505
F506	S-pattern lower-limit adjustment amount	1%	0	50	10		506
F507	S-pattern upper-limit adjustment amount	1%	0	50	10		507
F601	Stall prevention level 1	1%	10	111	110		601
F602	Inverter trip retention selection	1	0	1	0		602
F603	Emergency stop selection	1	0	2	0		603
F604	Emergency DC braking time	0.1sec	0,0	20,0	1		604
F605	Output phase failure detection mode selection	1	0	5	3	5	605
F607	Motor 150%-overload time limit	1sec	10	2400	300		607
F608	Input phase failure detection mode selection	1	0	1	1		608
F609	Hysteresis for small current detection	1%	1	20	10		609
F610	Low current trip/alarm	1	0	1	0		610
F611	Small current detection current	1%	0	100	0		611
F612	Small current detection time	1sec	0	255	0		612
F613	Detection of output short-circuit during start-up	1	0	3	0		613
F615	Over-torque trip/alarm selection	1	0	1	0		615
F616	Over-torque detection level	1%	0	250	130		616
F618	Over-torque detection time	0.1sec	0,0	10,0	0.5		618
F619	Over-torque detection level hysteresis	1%	0	100	10		619
F621	Cumulative operation time alarm setting	0.1	0,0	999,9	610		621
F626	Over-voltage stall protection level	1%	100	150	140		626
F627	Under-voltage trip/alarm selection	1	0	2	0		627
F632	Thermal memory selection	1	0	1	0		632
F633	Trip at VIA low level input mode	1%	0	100	0		633
F634	Annual avg ambient temp (calculation for life alarms)	1	1	6	3		634
F645	Selection of PTC thermal	1	0	2	0		645
F646	Detection level of PTC	1ohm	100	9999	3000		646
F650	Rorced/Fire-speed control selection	1	0	1	0		650
F691	Inclination characteristic of analog output	1	0	1	1		691
F692	Meter bias	1%	0	100	0		692
F700	Prohibition of change of parameter settings	1	0	1	0		700
F701	Unit selection	1	0	1	1		701
F702	Free unit selection	0.01	0,00	200,00	0		702
F705	Inclination characteristic of free unit display	1	0	1	1		705

Figure 36 continued: ATV 212 (MD2) Drive Parameters

PART NUMBER		REV B	PART DESCRIPTION				
170632000			Rooftop - MT3 SAF (set 321) PARAMETERS				
			Drive ATV21	Voltage ALL	HP ALL	Application SAF/RAF, RT/SC	
Code	Function Description	Unit	Min. Value	Max. Value	Default Value	New Value	Logical Address
F706	Free unit display bias	0.01Hz	0,00	80,00	0		706
F707	Free step 1 (pressing a panel key once)	0.01Hz	0,00	80,00	0		707
F708	Free step 2 (panel display)	1	0	255	0		708
F710	Standard monitor display selection	1	0	10	0		710
F721	Panel stop pattern	1	0	1	0		721
F730	Prohibition of freq. setting on the operation panel (FC)	1	0	1	0		730
F732	Panel operation prohibition (Local/Remote keys)	1	0	1	0	1	732
F733	Panel operation prohibition (RUN/STOP keys)	1	0	1	0		733
F734	Prohibition of panel emergency stop operation	1	0	1	0		734
F735	Prohibition of panel reset operation	1	0	1	0		735
F738	Selection of AUF	1	0	1	0		738
F748	Selection of watt hour memory	1	0	1	1		748
F749	Display unit selection of watt hour	1	0	3	0		749
F800	Communication band speed	1	0	1	1		800
F801	Parity	1	0	2	1	=0; McQuay	801
F802	Inverter number; SAF=1;RAF=2;HW=3	1	0	247	1	=1;McQuay	802
F803	Communication error trip time	1sec	0	100	3	10	803
F805	Communication waiting time	0.01sec	0,00	2,00	0		805
F806	Setting master & slave for comm between inverters	1	0	4	0		806
F811	Communication input point 1 setting	1%	0	100	0		811
F812	Communication input point 1 frequency	0.01Hz	0,00	200,00	0		812
F813	Communication input point 2 setting	1%	0	100	100		813
F814	Communication input point 2 frequency	0.01Hz	0,00	200,00	0	=60;McQuay	814
F829	Selection of communication protocol	1	0	4	1		829
F851	Inverter action at network & communication break	1	0	4	4	0	851
F856	Number of motor poles for comm speed calculation	1	1	8	2		856
F870	Block write data 1	1	0	6	0		870
F871	Block write data 2	1	0	6	0		871
F875	Block read data 1	1	0	11	0		875
F876	Block read data 2	1	0	11	0		876
F877	Block read data 3	1	0	11	0		877
F878	Block read data 4	1	0	11	0		878
F879	Block read data 5	1	0	11	0		879
F880	Free notes	1	0	65535	0	321	880
F890	Parameter for option 1	1	0	65535	0		890
F891	Parameter for option 2	1	0	65535	0		891
F892	Parameter for option 3	1	0	65535	0		892
F893	Parameter for option 4	1	0	65535	0		893
F894	Parameter for option 5	1	0	65535	0		894
F895	Parameter for option 6	1	0	65535	0		895
F896	Parameter for option 7	1	0	65535	0		896
F897	Parameter for option 8	1	0	65535	0		897
F898	Parameter for option 9	1	0	65535	0		898
F899	Parameter for option 10	1	0	65535	0		899
F910	Step-out detection current level (for PM motors)	1%	10	150	100		910
F911	Step-out detection time (for PM motors)	0.1sec	0,0	25,0	0.0		911
F912	q-axis self-inductance (for PM)	0.01mH	0,00	650,00	0.00		912

Figure 36 continued: ATV 212 (MD2) Drive Parameters

PART NUMBER		REV B	PART DESCRIPTION				
170632000			Rooftop - MT3 SAF (set 321) PARAMETERS				
			Drive ATV21	Voltage ALL	HP ALL	Application SAF/RAF, RT/SC	
Code	Function Description	Unit	Min. Value	Max. Value	Default Value	New Value	Logical Address
F706	Free unit display bias	0.01Hz	0,00	80,00	0		706
F707	Free step 1 (pressing a panel key once)	0.01Hz	0,00	80,00	0		707
F708	Free step 2 (panel display)	1	0	255	0		708
F710	Standard monitor display selection	1	0	10	0		710
F721	Panel stop pattern	1	0	1	0		721
F730	Prohibition of freq. setting on the operation panel (FC)	1	0	1	0		730
F732	Panel operation prohibition (Local/Remote keys)	1	0	1	0	1	732
F733	Panel operation prohibition (RUN/STOP keys)	1	0	1	0		733
F734	Prohibition of panel emergency stop operation	1	0	1	0		734
F735	Prohibition of panel reset operation	1	0	1	0		735
F738	Selection of AUF	1	0	1	0		738
F748	Selection of watt hour memory	1	0	1	1		748
F749	Display unit selection of watt hour	1	0	3	0		749
F800	Communication band speed	1	0	1	1		800
F801	Parity	1	0	2	1	=0; McQuay	801
F802	Inverter number; SAF=1;RAF=2;HW=3	1	0	247	1	=1;McQuay	802
F803	Communication error trip time	1sec	0	100	3	10	803
F805	Communication waiting time	0.01sec	0,00	2,00	0		805
F806	Setting master & slave for comm between inverters	1	0	4	0		806
F811	Communication input point 1 setting	1%	0	100	0		811
F812	Communication input point 1 frequency	0.01Hz	0,00	200,00	0		812
F813	Communication input point 2 setting	1%	0	100	100		813
F814	Communication input point 2 frequency	0.01Hz	0,00	200,00	0	=60;McQuay	814
F829	Selection of communication protocol	1	0	4	1		829
F851	Inverter action at network & communication break	1	0	4	4	0	851
F856	Number of motor poles for comm speed calculation	1	1	8	2		856
F870	Block write data 1	1	0	6	0		870
F871	Block write data 2	1	0	6	0		871
F875	Block read data 1	1	0	11	0		875
F876	Block read data 2	1	0	11	0		876
F877	Block read data 3	1	0	11	0		877
F878	Block read data 4	1	0	11	0		878
F879	Block read data 5	1	0	11	0		879
F880	Free notes	1	0	65535	0	321	880
F890	Parameter for option 1	1	0	65535	0		890
F891	Parameter for option 2	1	0	65535	0		891
F892	Parameter for option 3	1	0	65535	0		892
F893	Parameter for option 4	1	0	65535	0		893
F894	Parameter for option 5	1	0	65535	0		894
F895	Parameter for option 6	1	0	65535	0		895
F896	Parameter for option 7	1	0	65535	0		896
F897	Parameter for option 8	1	0	65535	0		897
F898	Parameter for option 9	1	0	65535	0		898
F899	Parameter for option 10	1	0	65535	0		899
F910	Step-out detection current level (for PM motors)	1%	10	150	100		910
F911	Step-out detection time (for PM motors)	0.1sec	0,0	25,0	0.0		911
F912	q-axis self-inductance (for PM)	0.01mH	0,00	650,00	0.00		912

Appendix I

Self-Contained DAC MCB Analog Inputs

MicroTech II Analog Input	MicroTech II Component	Label	Special Notes	MicroTech III Wiring Location
MCB-AI1	Zone Temperature Sensor	N/A	Replace with Wall Sensor with 10kΩ Type 2 Thermistor.	MCB-X3
MCB-AI2	DAT Reset	If keeping: DAT Reset Signal and DAT Reset Common No label needed if replaced.	If a 0-10VDC signal: Keep DAT Reset wires. Remove wire from AI2, label as DAT Reset Signal. Remove common wire and label as DAT Reset Common. If 0-5 VDC: MicroTech III will not accept as DAT Reset Signal. DAT Reset Signal will need to be changed to 0-10VDC or 4-20mA.	MCB-X4
MCB-AI3	DAT	N/A	Replace with 10kΩ Type 2 Thermistor.	MCB-AI1
MCB-AI4	RAT	N/A	Replace with 10kΩ Type 2 Thermistor.	MCB-AI2
MCB-AI5	OAT	N/A	Replace with 10kΩ Type 2 Thermistor.	MCB-AI3
MCB-AI6	MAT	N/A	Replace with 10kΩ Type 2 Thermistor.	MCB-X8
MCB-AI7	EWT	N/A	Replace with 10kΩ Type 2 Thermistor.	MCB-X1
MCB-AI8	LWT	N/A	LWT Sensor not used on MicroTech III.	N/A
MCB-AI9	OA damper position	N/A	OA Damper feedback not used on MicroTech III.	N/A
MCB-AI10	Heating valve	N/A	Heating Valve feedback not used on MicroTech III.	N/A
MCB-AI11 (option)	Cooling valve	N/A	Cooling Valve feedback not used on MicroTech III.	N/A
MCB-AI11 (option)	Refrigerant Pressure #1	N/A	Replace with Refrigerant Pressure Transducer to operate with 410a refrigerant pressures. See parts list.	EXPA-X7
MCB-AI12	Refrigerant Pressure #2	N/A	Replace with Refrigerant Pressure Transducer to operate with 410a refrigerant pressures. See parts list.	EXPA-X8
MCB-AI13	Duct static pressure #1	N/A	MicroTech III will not accept 0-5VDC or 0-10VDC Duct Static Pressure signal. Duct Static Pressure transducer needs to be replaced with a transducer capable of 4-20mA output. Duct Static Pressure may be wired into SF Variable Frequency Drive.	EXPA-X2
MCB-AI14	Duct static pressure #2/ building static pressure (optional)	N/A	MicroTech III will not accept 0-5VDC or 0-10VDC Duct Static Pressure signal. Duct Static Pressure/Building Static Pressure transducer needs to be replaced with a transducer capable of 4-20mA output. MicroTech III will not accept a Building Static Pressure transducer on MicroTech III. Building Static Pressure will be wired into RF/EF Variable Frequency Drive. Duct Static Pressure #2 will be wired into the SF Variable Frequency Drive.	N/A
MCB-AI15	N/A	N/A	SF feedback not used on MicroTech III.	N/A
MCB-AI16	N/A	N/A	Not used.	N/A

Self-Contained SCC MCB Analog Inputs

MicroTech I ADI Digital Inputs	MicroTech I Component	Label	Special Notes	MicroTech III Wiring Location
MCB-AI1	Zone Temperature Sensor	N/A	Replace with Wall Sensor with 10kΩ Type 2 Thermistor.	MCB-X3
MCB-AI2	Remote Space Temperature Set Point (optional)	N/A	Replace with Wall Sensor with 10kΩ Type 2 Thermistor.	MCB-X4
MCB-AI3	DAT	N/A	Replace with 10kΩ Type 2 Thermistor.	MCB-AI1
MCB-AI4	RAT	N/A	Replace with 10kΩ Type 2 Thermistor.	MCB-AI2
MCB-AI5	OAT	N/A	Replace with 10kΩ Type 2 Thermistor.	MCB-AI3
MCB-AI6	MAT	N/A	Replace with 10kΩ Type 2 Thermistor.	MCB-X8
MCB-AI7	EWT	N/A	Replace with 10kΩ Type 2 Thermistor.	MCB-X1
MCB-AI8	LWT	N/A	LWT Sensor not used on MicroTech III.	N/A
MCB-AI9	OA Damper position	N/A	OA Damper feedback not used on MicroTech III.	N/A
MCB-AI10	Heating valve	N/A	Heating Valve feedback not used on MicroTech III.	N/A
MCB-AI11 (option)	Cooling valve	N/A	Cooling Valve feedback not used on MicroTech III.	N/A
MCB-AI11 (option)	Refrigerant Pressure #1	N/A	Replace with Refrigerant Pressure Transducer to operate with 410a refrigerant pressures. See parts list.	EXPA-X7
MCB-AI12	Refrigerant Pressure #2	N/A	Replace with Refrigerant Pressure Transducer to operate with 410a refrigerant pressures. See parts list.	EXPA-X8
MCB-AI13	Not Used	N/A	Not used.	N/A
MCB-AI14	Not Used	N/A	Not used.	N/A
MCB-AI15	Not Used	N/A	Not used.	N/A
MCB-AI16	Relative humidity	If keeping sensor: RH Signal and RH Common. No label needed if replaced	If RH sensor uses 0-10VDC output: Keep RH Sensor. Remove wire from AI-16, label as RH Signal. Remove common wire and label as RH Common. If 0-5 VDC: MicroTech III will not accept RH sensor input. RH sensor will need to be replaced with a sensor capable of 0-10VDC or 4-20mA output.	EXPA-X6

Self-Contained DAC-SCC MCB Binary Inputs

MicroTech II Binary Input	MicroTech II Component	Label	Special Notes	MicroTech III Wiring Location
MCB-BI1	External Time Clock/Tenant Override	Time Clock/Tenant Override/S7 On	Remove wire from BI1 and label as Time Clock. ON side of S7 switch connected to BI1 through terminal block.	MCB-DI3
MCB-BI2	Manual System Disable	N/A	Keep S7 switch, but OFF is not used on MicroTech III.	N/A
MCB-BI3	Remote Cool Enable	N/A	Remove Cool Enable not used in MicroTech III.	N/A
MCB-BI4	Remote Heat Enable	N/A	Remove Heat Enable not used in MicroTech III.	N/A
MCB-BI5	Heat Failure Alarm	N/A	Remove R24. No heat alarm from FSG available on MicroTech III.	N/A
MCB-BI6	Airflow Status	PC7 DI and PC7 Common	Keep Normally Open PC7 switch. Label wire from BI6 as PC7 Digital Input. Remove other PC7 wire from TB1 and label as PC7 Common.	PC7: MCB-DI3 and M
MCB-BI7	Freeze Alarm (Freezestat)	FS1-X5 and FS1 -M	Keep FS1 switch. Remove wire from BI7 and label as FS1-X5. Remove wire on other side of switch from terminal block and label FS1-M.	FS1: MCB X5 with 1k resistor in series with switch
MCB-BI8	Smoke Alarm	Smoke Alarm/Emergency Off	Keep Only Normally Closed Contacts for smoke alarm indication. Remove R61 and R66. Remove wire from BI8 and label as MCB-DI4.	MCB-DI4
MCB-BI9	Filter Switch	PC5-DI2 and PC5-M	Keep PC5 switch. Remove wire from BI9 and label as MCB-DI2. Disconnect wire from other side of PC5 switch (24VAC supply) and label as PC5-M.	PC5: MCB-DI2 and M
MCB-BI10	Not Used	N/A	Not used on MicroTech II or MicroTech III.	N/A
MCB-BI11	OAE Status	OAE Switch	Remove wires from MCB-BI11 and TB1B and label both as OAE switch. 1.5k resistor needs to be added in series with MicroTech III input.	MCB-X5 and M
MCB-BI12	Not Used	N/A	Not used on MicroTech II or MicroTech III.	N/A
MCB-BI13	Not Used	N/A	Remove EXS. MicroTech III receives EF status through MB.	N/A
MCB-BI14	DHL	DHL	Keep DHL. Disconnect wires from BI14 and TB1. Label both wires as DHL. R63 will need to be added in series for switch indication state.	N/A
MCB-BI15	Not Used	N/A	Not used on MicroTech II or MicroTech III.	N/A
MCB-BI16	Water Flow Switch	WFS 24VAC, WFS Common, WFS Out	Keep WFS. An additional relay (R11) will need to be wired into the output of the WFS. When the switch closes, the relay energizes and closes a set of NO contacts to close the circuit between EXPA-X5 and M. Label 24VAC Power and Common on WFS. Remove wire from BI15 and label.	EXPA-X5

Self-Contained DAC-SCC MCB Binary Outputs

MicroTech II MCB BO	MicroTech II Component	Label	Special Notes	MicroTech III Wiring Location
MCB-BO1	DAF On/Off	DO5-1 and DO5-2	On MicroTech III, MCB-DO5 is the fan enable. On MicroTech II, BO1 is in series with R67 relay (24VAC). This relay will be replaced with 120VAC relay and will become R63 on MicroTech III. DO5 will be wired in series with NO R63 relay contact in SF Variable Frequency Drive bypass circuit.	MCB-DO5
MCB-BO2	RF On/Off	N/A	NO open set of R63 relay contacts will be wired into RF/EF Variable Frequency Drive enable circuit. MCB-BO2 on MicroTech II does not have a similar function on MicroTech III. R68 will be removed and not used. Remove all associated wires with BO2 and R68.	N/A
MCB-BO3	Fan Operation Output Signal	DO10-1 and DO10-2	Remove both wires from BO3 and label. R26 relay will be kept and contacts will be used.	MCB-DO10
MCB-BO4	Alarm Output Signal	BO4-1 and BO4-2	Remove both wires from BO4 and label.	MCB-DO9
MCB-BO5	Close Waterside Economizer	N/A	MicroTech III does not use floating point control. Instead, it uses a direct analog signal for OA damper capacity. BO5 will not be used. ACT3 will be replaced unless it can be configured to accept analog signal.	MCB-X7
MCB-BO6	Open Waterside Economizer	N/A	MicroTech III does not use floating point control. Instead, it uses a direct analog signal for OA damper capacity. BO6 will not be used. ACT3 will be replaced unless it can be configured to accept analog signal.	MCB-X7
MCB-BO7	Close Bypass/Water Regulating Valve	N/A	MicroTech III does not use floating point control. Instead, it uses a direct analog signal for OA damper capacity. BO7 will not be used, remove wires. MicroTech III uses 2-10 VDC Signal on MicroTech III. May need to replace valve if it cannot accept analog signal.	MCB-X6
MCB-BO8	Open Bypass/Water Regulating Valve	N/A	MicroTech III does not use floating point control. Instead, it uses a direct analog signal for OA damper capacity. BO8 will not be used, remove wires. MicroTech III uses 2-10 VDC Signal on MicroTech III. May need to replace ACT 2 if it cannot accept analog signal.	MCB-X6
MCB-BO9	Close Heating Valve	N/A	MicroTech III does not use floating point control. Instead, it uses a direct analog signal for heating capacity (VM1). BO9 will not be used, remove wires. MicroTech III uses 2-10 VDC Signal on MicroTech III. May need to replace VM1 if it cannot accept analog signal.	EXPB-X7
(option)	Enable Electric Heat Stage 1	BO9-1 and BO9-2	If the unit is equipped with Staged or SCR electric heat, BO9 will be used for heat enable. Remove wires from BO9 and label.	EXPB-DO1
MCB-BO10	Open heating valve	N/A	MicroTech III does not use floating point control. Instead, it uses a direct analog signal for heating capacity (VM1). BO10 will not be used, remove wires. MicroTech III uses 2-10 VDC Signal on MicroTech III. May need to replace VM1 if it cannot accept analog signal.	EXPB-X7
(option)	Enable Electric Heat Stage 2	BO10-1 and BO10-2	If the unit is equipped with Staged or SCR electric heat, BO10 will be used for heat enable. Remove wires from BO10 and label.	EXPB-DO2

MCB-BO11	Cool Enable	N/A	Cool Enable not used on MicroTech III.	EXPB-DO1
MCB-BO12	VAV box output signal	DO10-1 and DO10-2	On MicroTech III, DO10 can be configured for VAV box output or Fan Operation. On MicroTech II, BO12 will wire into DO10s output if controller uses VAV box output signal instead of Fan Operation.	MCB-DO10
MCB-BO13	Decrease discharge fan Variable Frequency Drive speed	N/A	Remove and dispose of R46 relay and wiring. MicroTech III controls SF speed through MB.	N/A
MCB-BO14	Increase discharge fan Variable Frequency Drive speed	N/A	Remove and dispose of R47 relay and wiring. MicroTech III controls SF speed through MB.	N/A
MCB-BO15	Not used.	N/A	Not used on MicroTech II.	N/A
MCB-BO16	Not used.	N/A	Not used on MicroTech II.	N/A

Appendix J

Self-Contained CCB1 Binary Inputs

Binary Inputs for CCB1	MicroTech II Component	Label	Special Notes	MicroTech III Wiring Location
CCB1-BI1	Circuit #1 HP Switch Status	MCB DO1-1 and MCB DO1-2	HP1 on MicroTech II is in series with R1 relay. R1 relay NO contacts open when relay de-energized (HP1 opens). Remove NO contact wires from B1 and 24VAC. Label wires.	MCB-DO1, HP1 NO contacts go to MCB-D15
CCB1-BI2	Circuit #2 HP Switch Status	MCB DO3-1 and MCB DO3-2	HP2 on MicroTech II is in series with R2 relay. R2 relay NO contacts open when relay de-energized (HP2 opens). Remove NO contact wires from B2 and 24VAC. Label wires.	MCB-DO3, R3 NO contacts go to EXPC-X3
CCB1-BI3	Circuit #3 HP Switch Status (independent circuits only)	MCB DO2-1 and MCB DO2-2	HP3 on MicroTech II is in series with R3 relay. R3 relay NO contacts open when relay de-energized (HP3 opens). Remove NO contact wires from B3 and 24VAC. Label wires.	MCB-DO1, HP2 NO contacts go to MCB-D16
(option)	Circuit #1 FP1 Switch Status (dual circuits only)	FP1-1 and FP1-2	FP1 on MicroTech II has the same function as FP1 on MicroTech III. Remove both wires and label. FP1 will be re-wired in series with LP1 and 1.5kΩ resistor.	MCB-X2
CCB1-BI4	Circuit #4 HP Switch Status (independent circuits only)	MCB DO4-1 and MCB DO4-2	HP4 on MicroTech II is in series with R4 relay. R4 relay NO contacts open when relay de-energized (HP4 opens). Remove NO contact wires from B4 and 24VAC. Label wires.	MCB-DO4, R4 NO contacts go to EXPC-X4
(option)	Circuit #2 FP2 Switch Status (dual circuits only)	FP2-1 and FP2-2	FP2 on MicroTech II has the same function as FP2 on MicroTech III. Remove both wires and label. FP2 will be re-wired in series with LP2 and 1kΩ resistor.	MCB-X2
CCB1-BI5	Circuit #1 LP1 switch status and FP1 switch status (independent circuits only)	LP2-1 and LP2-2	LP1 on MicroTech II has the same function as LP1 on MicroTech III. Remove both wires and label. LP1 Will be rewired in series with FP1 and 1.5kΩ resistor.	MCB-X2
(option)	Circuit #1 LP1 switch status (dual circuits only)	LP1-1 and LP1-2	LP1 on MicroTech II has the same function as LP1 on MicroTech III. Remove both wires and label. LP1 will be re-wired in series with FP1 and 1kΩ resistor.	MCB-X2
CCB1-BI6	Circuit #2 LP2 switch status and FP2 switch status (independent circuits only)	LP2-1 and LP2-2	LP2 on MicroTech II has the same function as LP2 on MicroTech III. Remove both wires and label. LP2 Will be rewired in series with FP2 and 1.5kΩ resistor.	MCB-X2
(option)	Circuit #2 LP2 switch status (dual circuits only)	LP1-1 and LP1-2	LP2 on MicroTech II has the same function as LP2 on MicroTech III. Remove both wires and label. LP2 will be re-wired in series with FP2 and 1kΩ resistor.	MCB-X2
CCB1-BI7	Circuit #3 LP3 and FP3 (independent circuits only)	LP3 and FP3	LP3 and FP3 on MicroTech II has the same function as LP3 and FP3 on MicroTech III. Remove both wires and label. LP3 will be re-wired in series with FP3.	EXPC-X1
CCB1-BI8	Circuit #4 LP4 and FP4 (independent circuits only)	LP4 and FP4	LP4 and FP4 on MicroTech II has the same function as LP4 and FP4 on MicroTech III. Remove both wires and label. LP4 will be re-wired in series with FP4.	EXPC-X2
CCB1-BI9	Compressor #1 Status (NO M1 contact)	N/A	MicroTech III does not look for compressor feedback status. NO contacts of M1 will not be used. Remove and dispose wires from CCB1 and M1.	N/A
CCB1-BI10	Compressor #2 Status (NO M2 contact)	N/A	MicroTech III does not look for compressor feedback status. NO contacts of M2 will not be used. Remove and dispose wires from CCB1 and M2.	N/A
CCB1-BI11	Compressor #3 Status (NO M3 contact)	N/A	MicroTech III does not look for compressor feedback status. NO contacts of M3 will not be used. Remove and dispose wires from CCB1 and M3.	N/A
CCB1-BI12	Compressor #4 Status (NO M4 contact)	N/A	MicroTech III does not look for compressor feedback status. NO contacts of M4 will not be used. Remove and dispose wires from CCB1 and M4.	N/A

Self-Contained CCB2 Binary Inputs

Binary Inputs for CCB2	MicroTech II Component	Label	Special Notes	MicroTech III Wiring Location
CCB2-BI1	Circuit #5 HP Switch Status	EXPA DO1-1 and EXPA DO1-2	HP5 on MicroTech II is in series with R5 relay. R5 relay NO contacts open when relay de-energized (HP5 opens). Remove NO contact wires from BI1 and 24VAC. Label wires.	EXPA-DO1, R5 NO contacts go to EXPC-X7
CCB2-BI2	Circuit #6 HP Switch Status	EXPA DO2-1 and EXPA DO2-2	HP6 on MicroTech II is in series with R6 relay. R6 relay NO contacts open when relay de-energized (HP6 opens). Remove NO contact wires from BI1 and 24VAC. Label wires.	EXPA-DO1, R6 NO contacts go to EXPC-X8
CCB2-BI3	Not Used	N/A	Not used on MicroTech II.	N/A
N/A	N/A	N/A	N/A	N/A
CCB2-BI4	Not Used	N/A	Not used on MicroTech II.	N/A
N/A	N/A	N/A	N/A	N/A
CCB2-BI5	Circuit #5 LP Switch	LP5-1 and LP5-2,	LP5 and FP5 on MicroTech II has the same function as LP5 and FP5 on MicroTech III. Remove both wires and label. LP5 will be re-wired in series with FP5.	EXPC-X5
N/A	N/A	N/A	N/A	N/A
CCB2-BI6	Circuit #6 LP Switch	LP6-1 and LP6-2	LP6 and FP6 on MicroTech II has the same function as LP6 and FP6 on MicroTech III. Remove both wires and label. LP6 will be re-wired in series with FP6.	EXPC-X6
N/A	N/A	N/A	N/A	N/A
CCB2-BI7	Not Used	N/A	Not used on MicroTech II.	N/A
CCB2-BI8	Not Used	N/A	Not used on MicroTech II.	N/A
CCB2-BI9	Compressor #5 Status (NO M5 contact)	N/A	MicroTech III does not look for compressor feedback status. NO contacts of M2 will not be used. Remove and dispose wires from CCB2 and M5.	N/A
CCB2-BI10	Compressor #6 Status (NO M6 contact)	N/A	MicroTech III does not look for compressor feedback status. NO contacts of M4 will not be used. Remove and dispose wires from CCB1 and M6.	N/A
CCB2-BI11	Not Used	N/A	Not used on MicroTech II.	N/A
CCB2-BI12	Not Used	N/A	Not used on MicroTech II.	N/A

Self-Contained CCB1 Binary Outputs

OBA Outputs	MicroTech I Component	Label	Special Notes	MicroTech III Wiring Location
CCB1-BO1	Compressor #1 ON/OFF	CCB1-BO1-1 and CCB1-BO1-2	BO1 on MicroTech II correlates to DO1 on MicroTech III. Remove wires from BO1 and label.	MCB C1 and MCB DO1B
CCB1-BO2	Compressor #2 ON/OFF	CCB1-BO2-1 and CCB1-BO2-2	BO2 on MicroTech II correlates to DO3 on MicroTech III. Remove wires from BO2 and label.	MCB C3 and MCB DO3
CCB1-BO3	Pump Start	CCB1 BO3 -1 and CCB BO3-2	Pump Signal on MicroTech II (BO3) functions the same on MicroTech III (DO8). Remove wires from BO3 and label.	MCB-DO8
CCB1-BO4	Circuit #1 Liquid Line Solenoid Valve (Open/Close)	SV1	Remove wire from CCB1-BO4, label. SV1 will not be directly controlled by the MicroTech III.	N/A
CCB1-BO5	Circuit #2 Liquid Line Solenoid Valve (Open/Close)	SV2	Remove wire from CCB2-BO4, label. SV2 will not be directly controlled by the MicroTech III.	N/A
CCB1-BO6	Compressor #3 ON/OFF	CCB1 BO6-1 and CCB1 BO6-2	BO6 on MicroTech II correlates to DO2 on MicroTech III. Remove wires from BO6 and label.	MCB C2 and MCB DO2
CCB1-BO7	Circuit #1 HGBP Valve	CCB1-BO7	MicroTech III Controls the Bypass Valve through a 2-10VDC signal, not an open-close BO.	MCB-X6
CCB1-BO8	Circuit #2 HGBP Valve	CCB1-BO8	MicroTech III Controls the Bypass Valve through a 2-10VDC signal, not an open-close BO.	MCB-X6
CCB1-BO9	Compressor #4 ON/OFF	CCB1 BO9-1 and CCB1 BO9-2	BO9 on MicroTech II correlates to DO4 on MicroTech III. Remove wires from BO9 and label.	MCB C4 and MCB DO4

Self-Contained CCB2 Binary Outputs

Binary Outputs for CCB2	MicroTech II Component	Label	Special Notes	MicroTech III Wiring Location
CCB2-BO1	Compressor #5 ON/OFF	CCB2 BO1-1 and CCB2 BO1-2	BO1 on MicroTech II correlates to EXP A-DO1 on MicroTech III. Remove wires from BO1 and label.	EXPA C1 and EXPA DO1
CCB2-BO2	Compressor #6 ON/OFF	CCB2 BO2-1 and CCB2 BO2-2	BO2 on MicroTech II correlates to EXP A-DO2 on MicroTech III. Remove wires from BO2 and label.	EXPA C2 and EXPA DO2
CCB2-BO3	Pump Start	CCB1 BO3 -1 and CCB BO3-2	Pump Signal on MicroTech II (BO3) functions the same on MicroTech III (DO8). Remove wires from BO3 and label.	MCB-DO8
CCB2-BO4	Not Used	N/A	Not used on MicroTech II.	N/A
CCB2-BO5	Not Used	N/A	Not used on MicroTech II.	N/A
CCB2-BO6	Not Used	N/A	Not used on MicroTech II.	N/A
CCB2-BO7	Not Used	N/A	Not used on MicroTech II.	N/A
CCB2-BO8	Not Used	N/A	Not used on MicroTech II.	N/A
CCB2-BO9	Not Used	N/A	Not used on MicroTech II.	N/A



Daikin Applied Training and Development

Now that you have made an investment in modern, efficient Daikin equipment, its care should be a high priority. For training information on all Daikin HVAC products, please visit us at www.DaikinApplied.com and click on Training, or call 540-248-9646 and ask for the Training Department.

Warranty

All Daikin equipment is sold pursuant to its standard terms and conditions of sale, including Limited Product Warranty. Consult your local Daikin Applied Representative for warranty details. To find your local Daikin Applied Representative, go to www.DaikinApplied.com.

Aftermarket Services

To find your local parts office, visit www.DaikinApplied.com or call 800-37PARTS (800-377-2787). To find your local service office, visit www.DaikinApplied.com or call 800-432-1342.

This document contains the most current product information as of this printing. For the most up-to-date product information, please go to www.DaikinApplied.com.

Products manufactured in an ISO Certified Facility.