

WHEELS - GOBO, COLOUR & ANIMATION

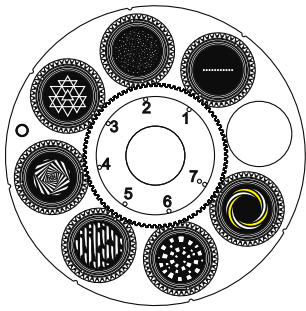

> Dimension/Tolerance/Requirement:

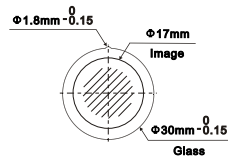

> Black&White Gobo: > Colour Gobo:

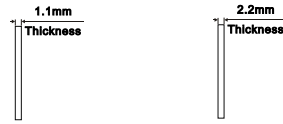

> Temperature Tolerance: 500°C

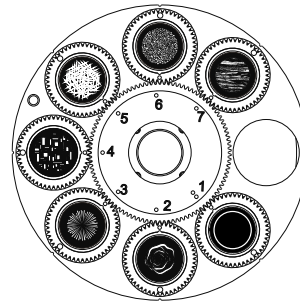

> Dimension/Tolerance/Requirement:

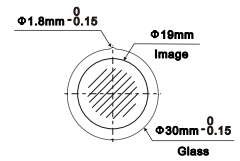

> Black & White Gobo:



> Temperature Tolerance: 500°C

GOBO WHEEL 1

Rotating Gobo

1	130	Dot Line 11	GPG0500190
2	075	Star Field	GPG0500194
3	018	Nested Triangle	GPG0500193
4	039	Infinite Stairs	GPG0500197
5	278	Bread Stix	GPG0500192
6	070	Circle of Square	GPG0500196
7	112Y	Nested Rings Yellow	GPG0500195

GOBO WHEEL 2

Rotating Gobo

1	410	Conical Tunnel Effect	GPG0500650
2	049	Smoke Rings	GPG0500198
3	047	Fireworks	GPG0500199
4	066	Abstract Square	GPG0500201
5	081	Iron Filings	GPG0500202
6	101	Deep Forest	GPG0500203
7	105	Tree Bark	GPG0500204

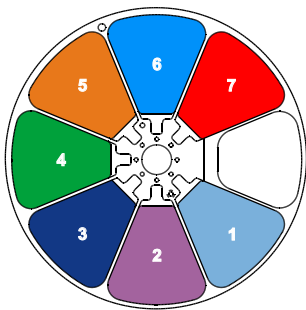

> Dimension:

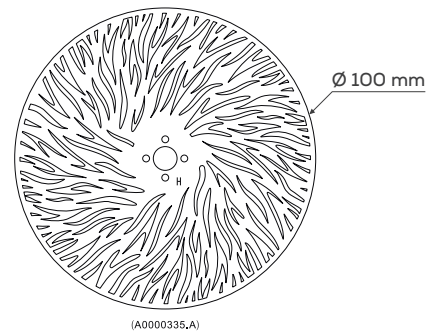
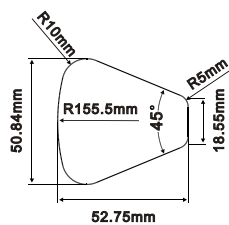

(A0000335,A)

COLOUR WHEEL

1	CTB 1/4	GPG0100097
2	Magenta	GPG0100098
3	Congo Blue	GPG0100099
4	Green	GPG0100100
5	Orange	GPG0100101
6	Blue	GPG0100102
7	Red	GPG0100103

ANIMATION WHEEL

-	-	GPA0000335D0
---	---	--------------

PRISMS & FROSTS

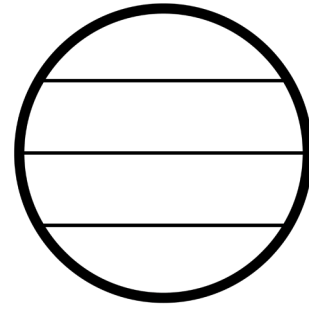
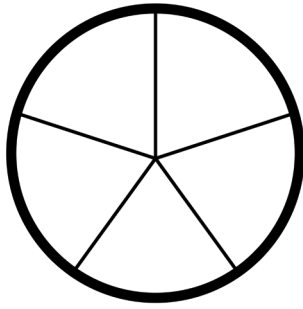

**PRISM 1**

DMX Channel 29 @ Std Mode / 41 @ Ext Mode

5-facet circular

-

**PRISM 2**

DMX Channel 31 @ Std Mode / 44 @ Ext Mode

4-facet linear

-



**FROST 1**

DMX Channel 33 @ Std Mode / 47 @ Ext Mode

Light 1°

-



**FROST 2**

DMX Channel 34 @ Std Mode / 48 @ Ext Mode

Heavy 5°

-

FIXTURE DRAWINGS

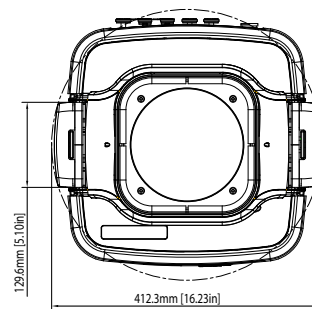
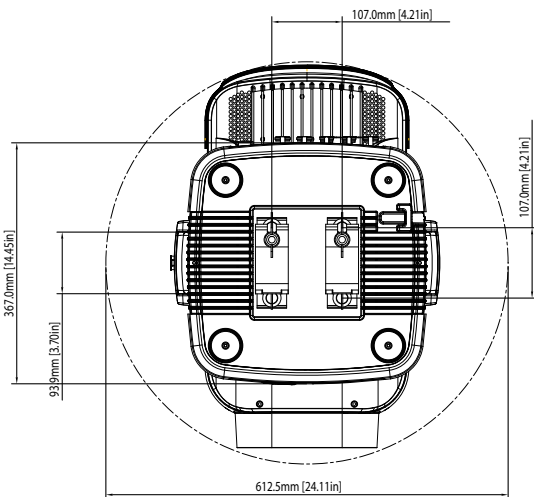
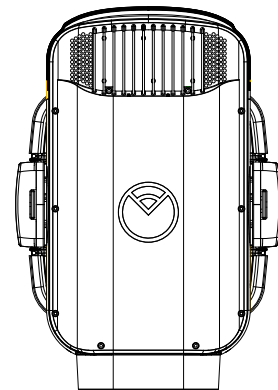
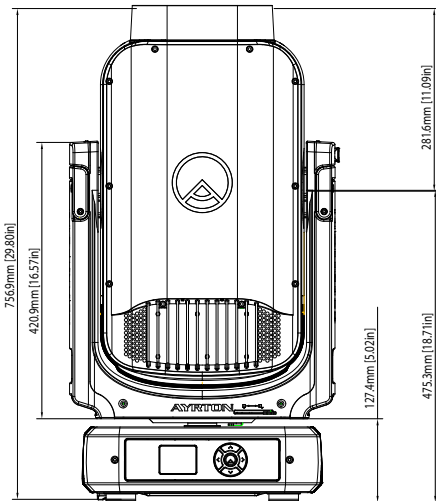
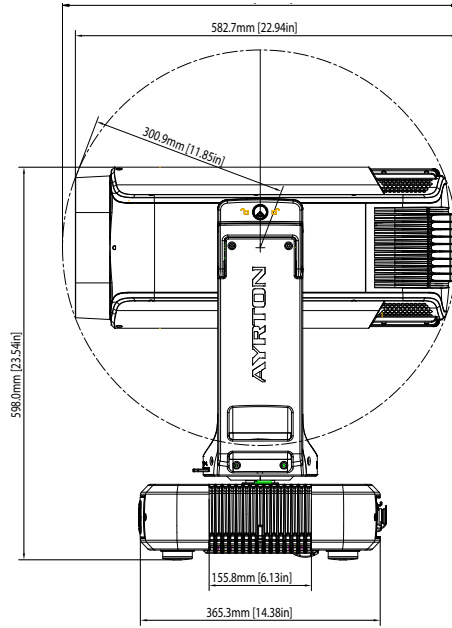
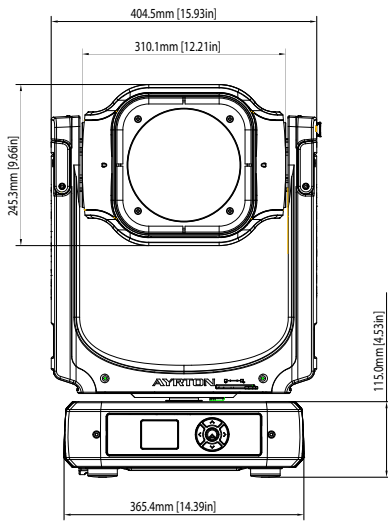

FOAM DRAWINGS

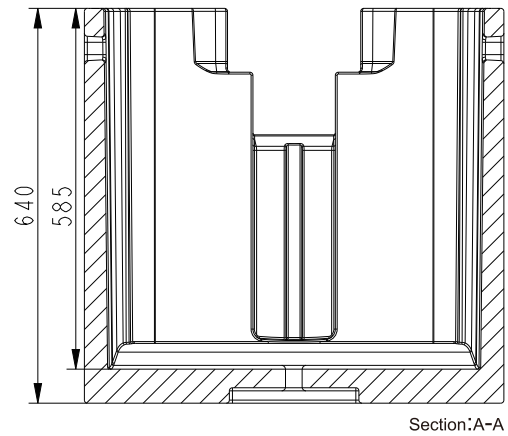
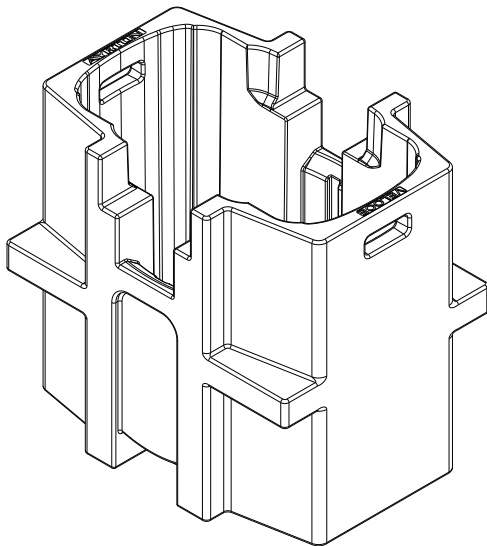
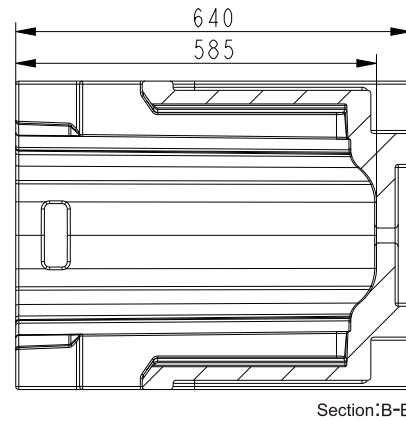
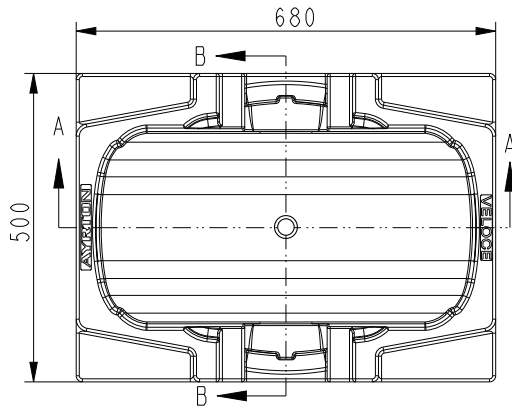

Dimension tolerance (mm):  $\pm 5$   
Version: 1.0

**⚠️ DISCLAIMER**

Errors and omissions for all information given in this document are possible. All information is subject to change without prior notice.