

# UPS5000-E-(400 kVA-600 kVA) Quick Guide (60 kVA Power Modules)

Issue: 06

Part Number: 31509985

Date: 2022-12-30



## 1 Overview

Model	UPS5000-E-400K-FMS	UPS5000-E-500K-FMS	UPS5000-E-600K-FMS
Weight (full configuration)	680 kg	800 kg	1025 kg
Dimensions (H x W x D)	2000 mm x 1200 mm x 850 mm		2000 mm x 1400 mm x 850 mm

### NOTICE

1. Before installation, read the user manual carefully to get familiar with product information and safety precautions.
2. Use insulated tools during installation and operation.
3. Only engineers certified by the Company or its agent are allowed to install, commission, and maintain the UPS. Otherwise, personal injury or equipment damage may occur, and the resulting UPS faults are beyond the warranty scope.

### UPS5000-E-400K-FMS

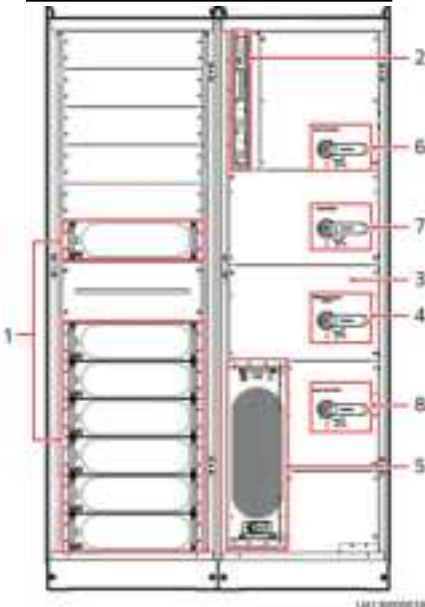

- (1) Power modules (2) Control module  
(3) Bypass module (4) Main input switch  
(5) Output switch (6) Maintenance bypass switch

### UPS5000-E-500K-FMS

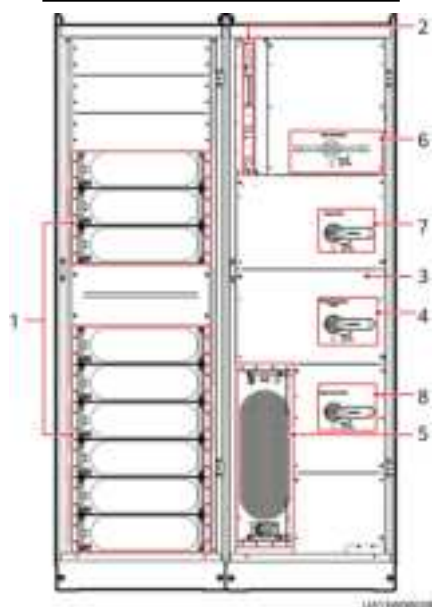

- (1) Power modules (2) Control module  
(3) Power distribution module covers (4) Maintenance bypass switch  
(5) Output switch (6) Bypass input switch

## UPS5000-E-600K-FMS

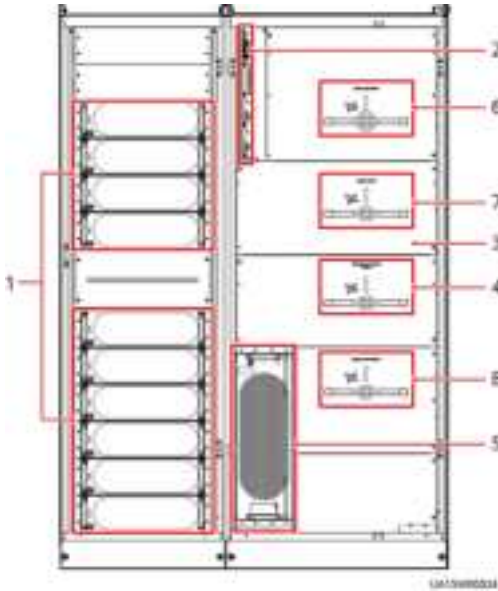

- (1) Power modules
- (2) Control module
- (3) Power distribution module covers
- (4) Maintenance bypass switch
- (5) Bypass module
- (6) Main input switch
- (7) Output switch
- (8) Bypass input switch

### NOTE

UPS5000-E-400K-SMS, UPS5000-E-500K-SMS, and UPS5000-E-600K-SMS are models in standard configuration. A UPS in standard configuration has no mains input switch, bypass input switch, or output switch.

## 2 Installing the UPS

### 2.1 Determining the UPS Installation Position

The UPS can be installed on the channel steel or floor. Determine the mounting hole positions using a marking-off template (unit: mm), drill holes, and install expansion sleeves based on site requirements.

A: Mounting holes on the channel steel    B: Mounting holes on the floor

### 400/500K Hole Dimensions

Unit: mm

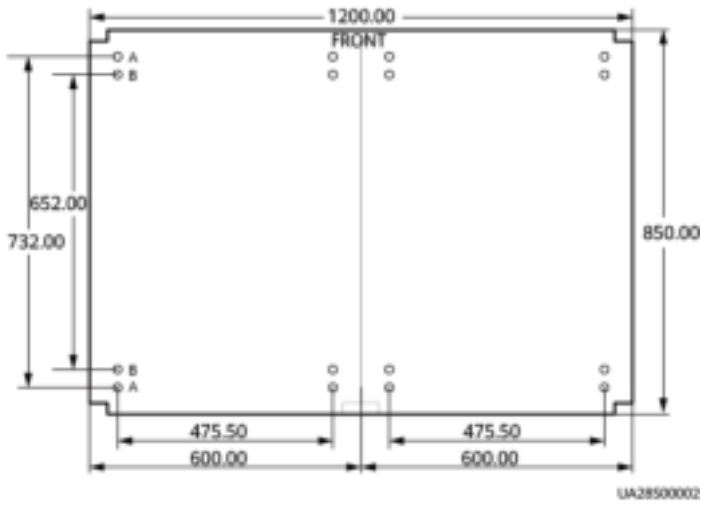

### 600K Hole Dimensions

Unit: mm

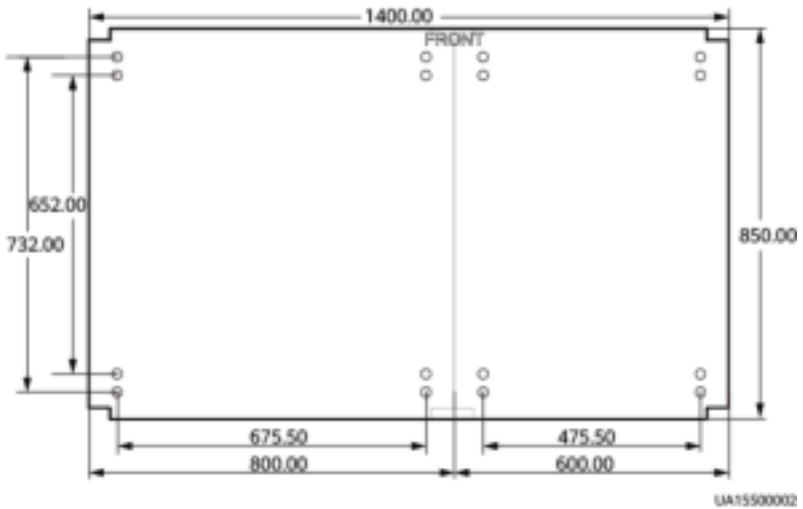

## 2.2 Securing the UPS

- Floor mounting: Secure the cabinet to the floor by using eight M12x60 expansion bolts.
- Channel steel mounting: Secure the cabinet to channel steel by using eight M12x60 common bolts.

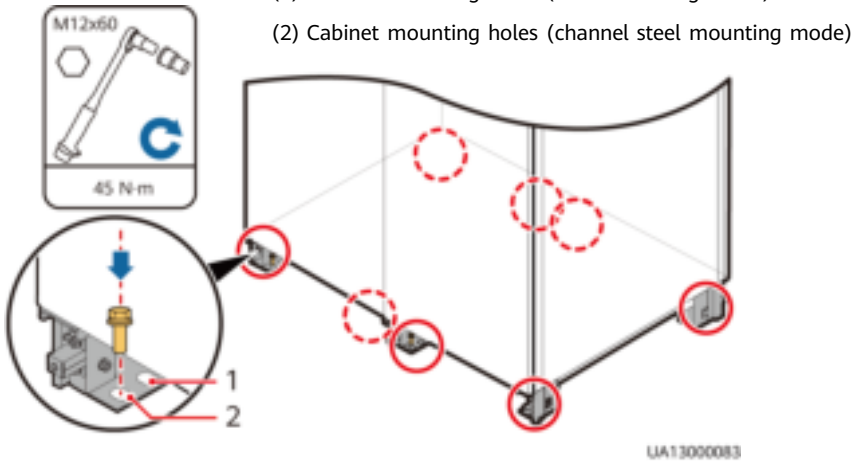

## 2.3 Installing the Front, Rear, Left, and Right Anchor Baffle Plates

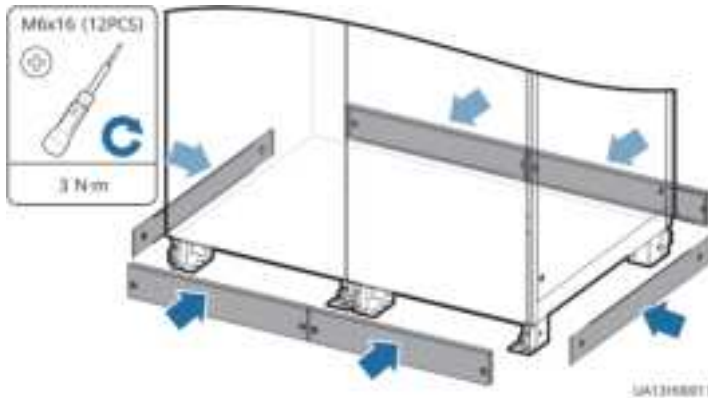

# 3 Installing Cables

## 3.1 UPS Cable Connection Reference

### WARNING

- Prepare cables away from the cabinets to prevent scraps from falling inside. Cable scraps may ignite and cause personal injury or device damage.
- After cables have been installed, clean the cabinets in a timely manner. Keep the cabinets and surrounding environment clean and tidy.
- You need to prepare terminals onsite. The stripped length of the copper wire should be the same as that of the part of the terminal that covers the conductor.

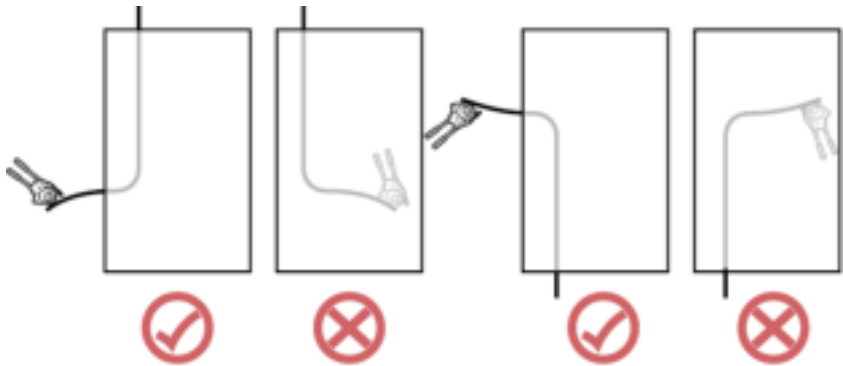

UA2110068

**NOTE**

The cabling route is for reference only. Connect cables based on site requirements.

### 3.2 Installing Cables

#### Scenario 1: Routing Cables from the Top

1. Open the front door of the bypass cabinet, and remove power distribution covers (UPS5000-E-400K-FMS is used as an example).
2. Remove the top cover from the cabinet based on cable routes and dimensions.



UA13H00017

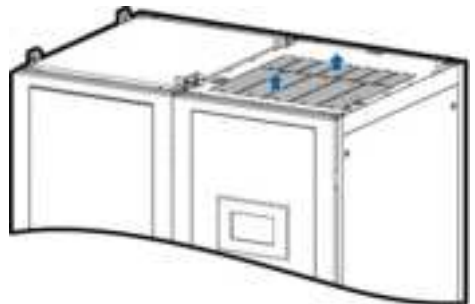

UA13H00019

3. Remove the copper bar between the mains and bypass inputs. (Skip this step if there is only one power source.)

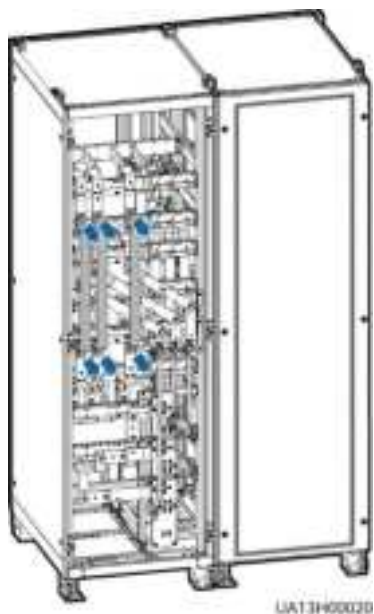

4. Connect the ground cable to the UPS.

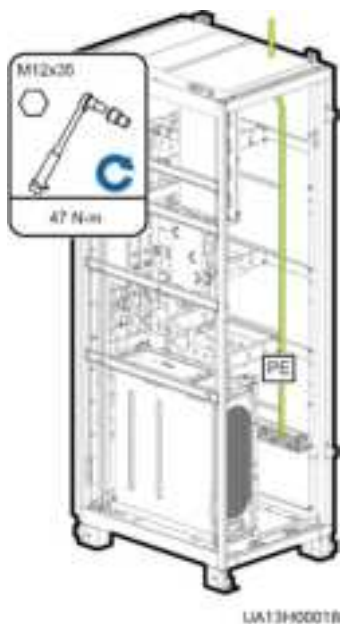

5. Connect the mains input power cable.

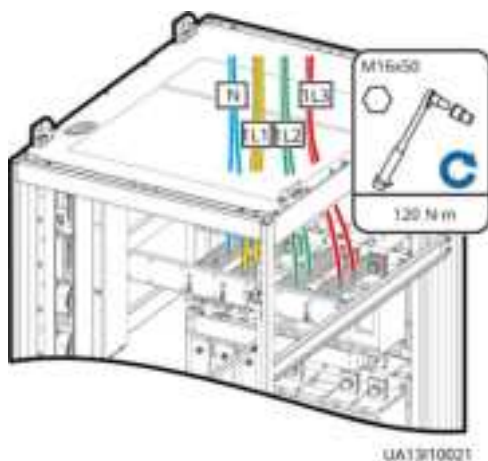

6. Connect the output power cable.

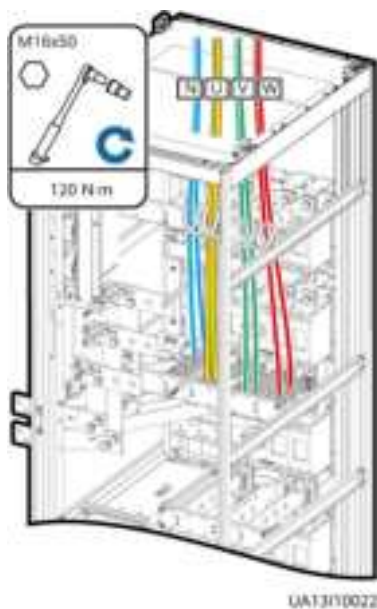

7. Connect the bypass input power cable.

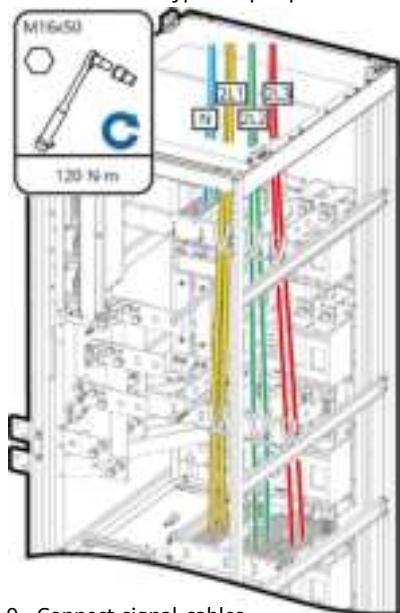

UA13110025

8. Connect the battery cable.

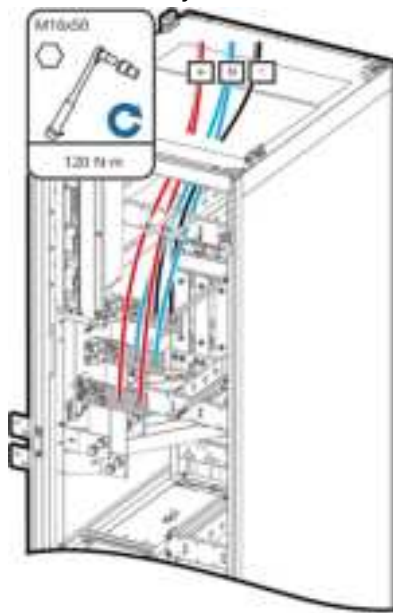

UA13000152

9. Connect signal cables.

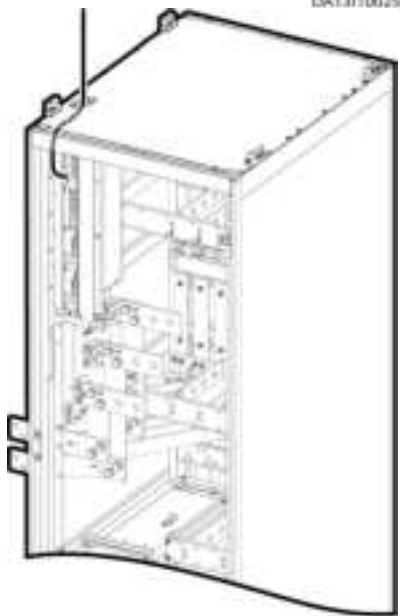

UA13110024

**NOTE**

Route a neutral wire from the middle of the positive and negative battery strings. Take a battery string consisting of 40 batteries as an example. A neutral wire is routed from the middle of positive and negative battery strings, each consisting of 20 batteries.

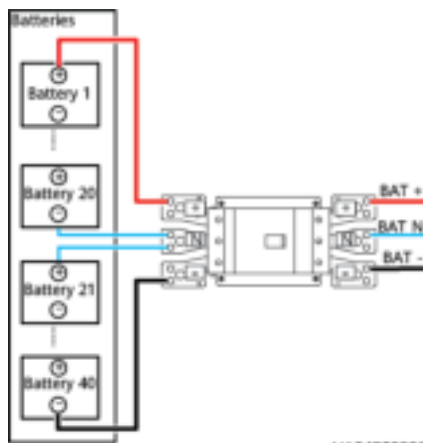

UA24P0001

**NOTE**

The figure shows the signal cable routing and is for reference only. Connect the cable based on the actual situation.

**NOTE**

For the cable connection method for the TN-C system, see the user manual.

## Scenario 2: Routing Cables from the Bottom

1. Remove the cable covers from the bottom of the cabinet, drill holes in the covers, attach grommet strips to the hole edges for protecting cables, and reinstall the cable covers.
2. Connect power cables and signal cables.

### NOTE

For the screw specifications and torque used for connecting cables in a bottom cable routing scenario, refer to the top cable routing scenario. This section only shows the cable routes in the bottom cable routing scenario.

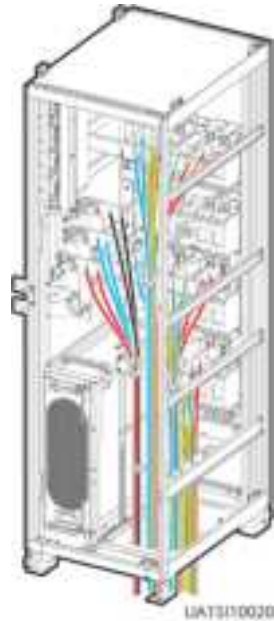

## 4 Verifying the Installation

1. Check that there is no foreign matter in the cabinet.

- (1) Switches
- (2) Mains input wiring copper bars
- (3) Battery input wiring copper bars
- (4) Output wiring copper bars
- (5) Bypass input wiring copper bars
- (6) Rear of the cabinet

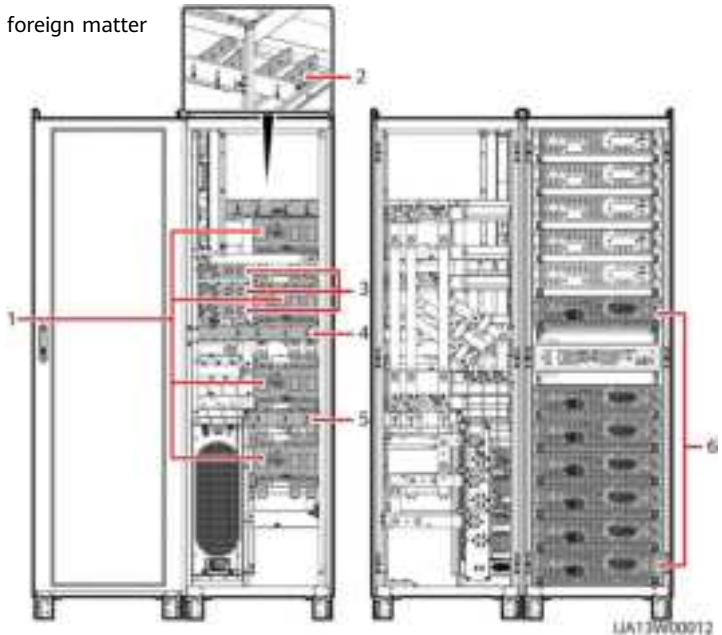



- After routing cables and checking cable connections, use sealing putty to fill in the gap between the cables and the cabinets. (Remove the paper protective film from the sealing putty and retain the transparent film. When using the putty, ensure that the transparent film faces upward.)

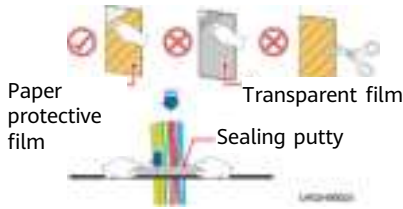

#### NOTICE

Sealing putty must be used as a whole and the gap can be sealed only from the top.

- After verifying the installation, reinstall all the covers.
- Do not remove the dust cover before power-on to prevent dust from entering the UPS.



## 5 Powering On and Starting the UPS

#### NOTICE

- Before powering on the UPS, ensure that the UPS has passed all check items in the *UPS5000 Commissioning and Acceptance Report* and Chapter 4.
- Measure the voltage and frequency of the mains and bypass inputs of the UPS, or the voltage and frequency output from the external input power distribution cabinet (PDC) to the UPS. Ensure that the line voltage is in the range of 138–485 V AC and the frequency is in the range of 40–70 Hz.

### 5.1 Powering On the UPS

Turn on the upstream bypass and mains input switches.

(For a UPS in full configuration) Turn on the UPS bypass input switch, output switch, and mains input switch.

After the UPS is powered on, initialization begins. The MDU displays an initialization progress bar.

## 5.2 Initial Startup

1. Obtain the startup password through the app. After the application is approved, enter the password on the service authorization screen of the device to complete device authorization.

### NOTICE

Technical support engineers can obtain the service authorization code through the app. For details, see the *Data Center Facility Deployment Guide*.

2. Set the language, time, date, network parameters, system parameters, and battery parameters on the **Settings Wizard** screen.

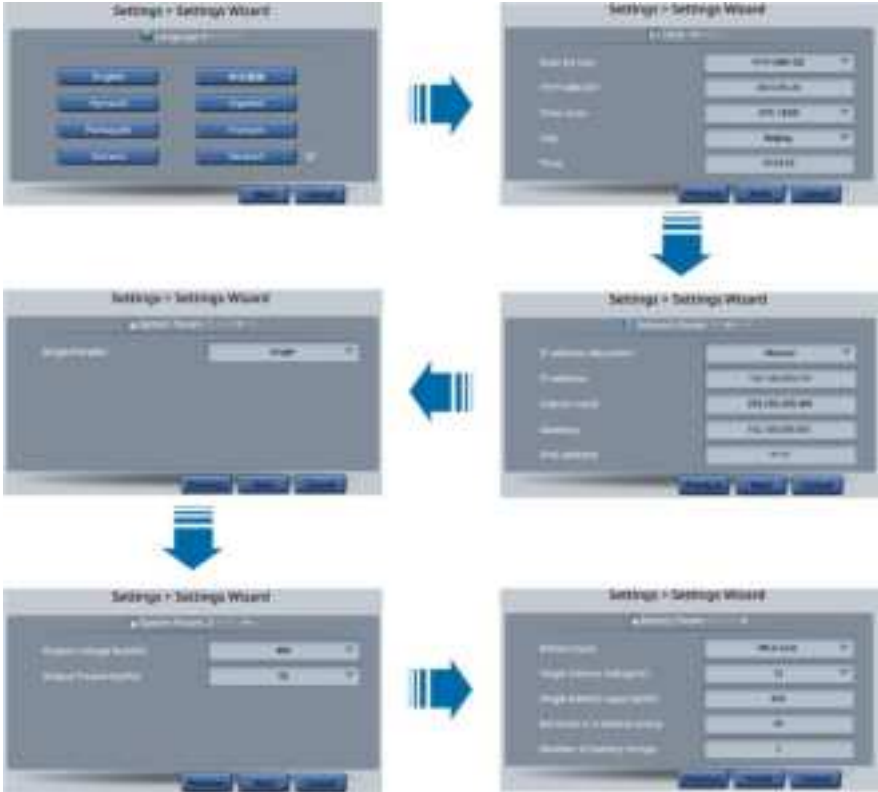

3. After you perform the settings, the **Bypass mode** and **No battery** alarms are reported by the MDU and do not need to be cleared. If there is any other alarm, you need to rectify the fault.
4. If the system has connected to the remote EPO switch, you need to choose **Monitoring > UPS System > Running Parameter > System Settings** on the WebUI and set **EPO detection** to **Enable**.
5. View the system running status diagram on the MDU to check that the UPS is working in bypass mode.

## 5.3 Starting the Inverter

1. On the main menu, choose **Common Functions** and tap **Inv. ON**.
2. In the displayed login window, enter the user name and password, and tap .
3. In the displayed dialog box, tap **Yes** to start the inverter.

### NOTE

To ensure system security, change the LCD and WebUI passwords after the first login.

System User	LCD Preset Password	WebUI Preset Password
admin (system administrator)	000001	Changeme
operator (common user)	000001	Changeme

### 5.3 Powering On Loads

1. After the inverter starts, the UPS works in normal mode. The **Bypass mode** alarm disappears.
2. After confirming that the battery strings are properly connected, turn on the battery string input circuit breaker. If there are multiple battery strings, turn on the circuit breaker for each battery string and then the general circuit breaker between battery strings and the UPS. The **No battery** alarm disappears from the MDU.
3. Turn on the UPS downstream output switch to supply power to the loads.

### 5.4 (Optional) Setting Parameters for the BCB Box

1. On the LCD, choose **Settings** > **Dry Contact Settings**, set **MUE05A connection** to **Enable**, and set **BCB connection [OL]** and **Battery breaker [STA]** to **Enable**.

## 6 Shutting Down the UPS

#### NOTICE

After the inverter is shut down, if the bypass is normal, the UPS transfers to bypass mode; if the bypass is not normal, the UPS supplies no power. Before shutting down the UPS, ensure that all loads have shut down.

### 6.1 Shutting Down the Inverter to Transfer the UPS to Bypass Mode

On the system LCD, choose **Common Functions** > **Inv. OFF**. After confirmation, the inverter is shut down.

### 6.2 Powering Off a Single UPS

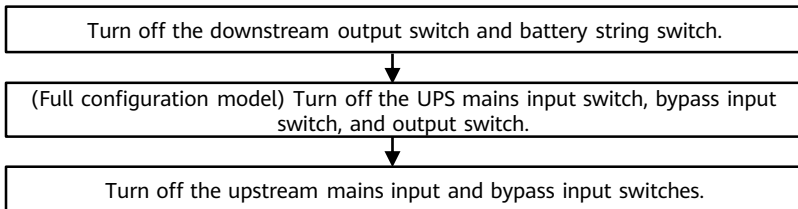

**Huawei Digital Power Technologies Co., Ltd.**

Huawei Digital Power Antuoshan Headquarters

Futian, Shenzhen 518043

People's Republic of China

[www.huawei.com](http://www.huawei.com)