

Single Pack SC12G 220-240V 50/60Hz CSIR

Codice Imballo Singolo: **195B4483**

Posizione	Titolo	Codice	Quantità
1	Compressor SC12G	104G8224	1
2	Starting relay	117U6003	1
3	Starting capacitor (80 μ F 220V, 6.3mm)	117U5017	1
4	Cord relief	103N1004	1
5	Cover	103N2009	1
6	Bolt joint for one compressor M6 \varnothing 16mm	118-1917	1

Secop GmbH • Lise-Meitner-Straße 29 • 24941 Flensburg, Germany • Tel: +49 46149410 • www.secop.com

Secop non si assume alcuna responsabilità per eventuali errori presenti in cataloghi, brochure e altro materiale stampato. Secop si riserva il diritto di modificare i propri prodotti senza preavviso. Ciò vale anche per i prodotti già ordinati, a condizione che tali modifiche possano essere apportate senza che siano necessarie modifiche successive alle specifiche già concordate. Tutti i marchi presenti in questo materiale sono di proprietà delle rispettive aziende. Secop e il logo Secop sono marchi di Secop GmbH. Tutti i diritti sono riservati.

Model

Designation	SC12G	220-240V/50Hz 1~ 220-240V/60Hz 1~	Sales code:	104G8224
-------------	--------------	-----------------------------------	-------------	-----------------

Compressor design

Oil type	Polyolester	Refrigerant(s)	R134a
Oil viscosity	22cST	Displacement	12,87cm ³ / 0,79cu.in
Oil quantity	500cm ³ / 16,9fl.oz	Compressors on pallet	80
Refr. charge - tech. limit	1300g / 45,9oz		
Free gas volume comp.	1510cm ³ / 51,1fl.oz		
Weight	12,7kg / 28lbs		
Motor protection	1# internal		
Winding resistance main	6,9Ω (at 25°C)		
Winding resistance aux	11Ω (at 25°C)		
Max. winding temp.	125°C / 257°F		
Max. discharge temp.	135°C / 275°F		



General - Configurations with SC12G

	Conf. 1	Conf. 2	Conf. 3	Conf. 4
Motorconfiguration	CSIR	CSIR	RSIR	RSIR
Power supply (nominal)	220-240V/50Hz	208-230V/60Hz	220-240V/50Hz	208-230V/60Hz
Number of phases	1	1	1	1
Voltage range	187-254V	198-254V	187-254V	198-254V
Approvals	CCC, VDE, KC	CCC, VDE, KC	CCC, VDE, KC	CCC, VDE, KC
Starting torque	HST	HST	LST	LST
Note	- / -			

Applications with SC12G

	Conf. 1	Conf. 2	Conf. 3	Conf. 4
Refrigerant	R134a	R134a	R134a	R134a
Application	LBP+MBP+HBP	LBP	LBP+MBP+HBP	LBP
System cooling	fan 3m/s	fan 3m/s	fan 3m/s	fan 3m/s
Hot gas defrost	OK	OK	OK	OK
Long interval pull down	OK	OK	OK	OK

Electrical data - Configurations with SC12G

	Conf. 1	Conf. 2	Conf. 3	Conf. 4
Starting device type	relay	relay	PTC	PTC
Run capacitor	- / -	- / -	- / -	- / -
Start capacitor	80μF	80μF	- / -	- / -
LRA (locked rotor amps / 4s)	13A	13A	12,6A	
RLA (rated load amps / 1s)	2,5A	2,5A	2,5A	- / -A
Cut in current	17A	17A	12,6A	

Model

Designation

SC12G

220-240V/50Hz 1~ 220-240V/60Hz 1~

Sales code:

104G8224

Compressor dimensions

Housing	A Height	209mm / 8,23in
	B Height	203mm / 7,99in
	C Length shell	218mm / 8,58in
	D Length w. cover	255mm / 10,04in
	E Width	151mm / 5,94in

Connectors	Suction	Discharge	Process
	X	Y	Z
Diameter [mm]	øi 10,11-10,29	øi 6,41-6,59	øi 6,41-6,59
(i:inside, o:outside) [in]	øi 0,4-0,41	øi 0,25-0,26	øi 0,25-0,26
Material	copper	copper	copper
Horizontal angle ±2°	37°	37°	143°
Vertical angle ±2°	30°	0°	150°
Position l/h/w [mm]	107/183/55	115/100/63	-107/183/55
[in]	4,2/7,2/2,2	4,5/3,9/2,5	-4,2/7,2/2,2
Straight tube l. [mm]	12	12	12
[in]	0,5	0,5	0,5

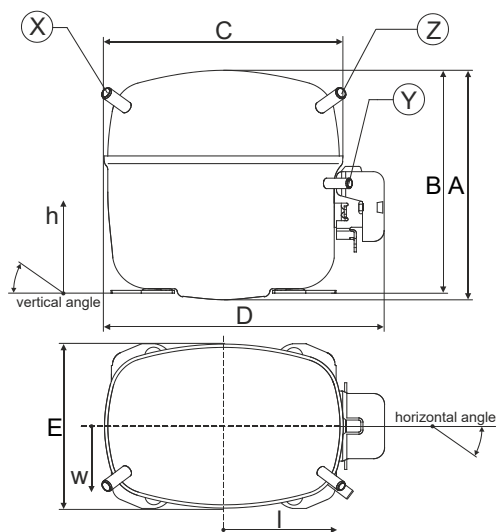

Compressor fixation

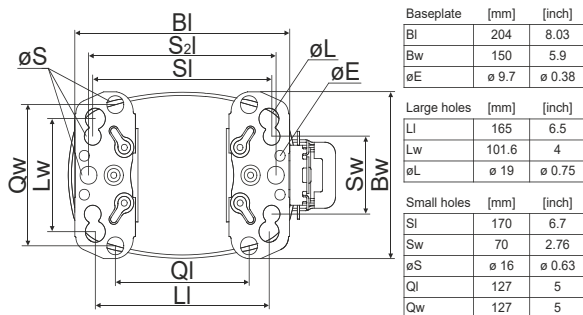

Bolt joint

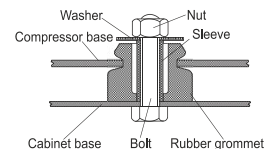

Snap-on

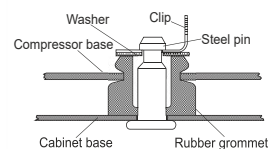

Mounting accessories

	one comp.	multi pack
Bolt joint M6 ø16mm	118-1917	118-1918
Bolt joint ø1/4" ø16mm	118-1946	
Bolt joint ø1/4" ø19mm	118-1949	
Snap-on ø7,3 ø16mm	118-1947	118-1919

Application notes

Provision for PE Grounding is located at the PE Stamp on the compressor

Model

Designation	SC12G	220-240V/50Hz	Conf. 1	Sales code:	104G8224
-------------	--------------	----------------------	----------------	-------------	-----------------

Configuration

Motorconfiguration	CSIR
Power supply (nominal)	220-240V/50Hz 1~
Refrigerant	R134a
Application	LBP+MBP+HBP
Voltage range	187-254V
Starting torque	HST
Approvals	CCC VDE KC

Electrical accessories / wiring diagram

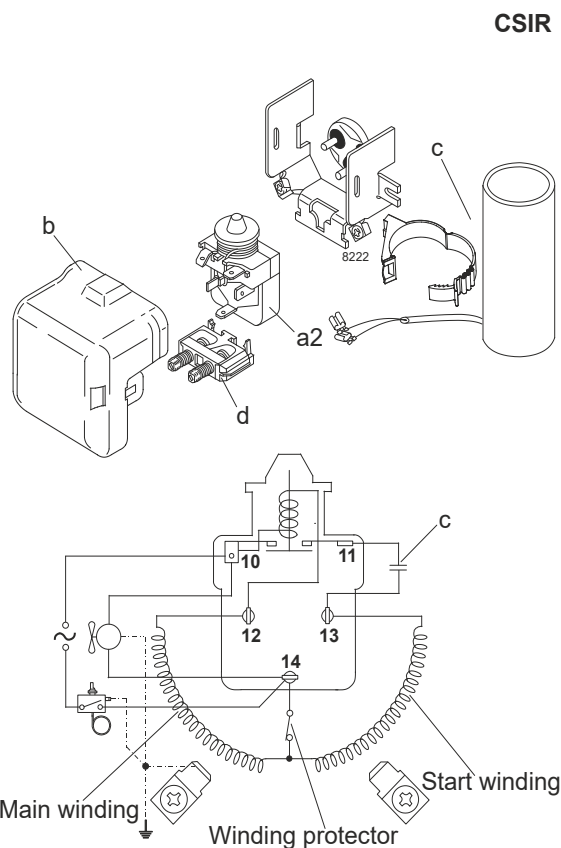

Ambient/ machine room temperatures minimum /maximum

Ambient temperature range:	10 - 43°C / 50 - 110°F
Machine room temperature range:	10 - 48°C / 50 - 119°F
Compressor cooling:	fan 3m/s

Operation Limits

Operation pressure range

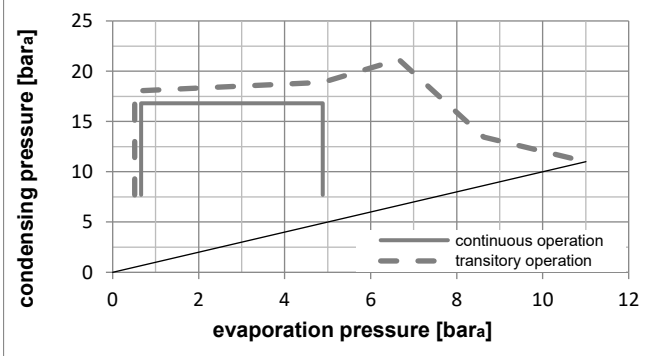
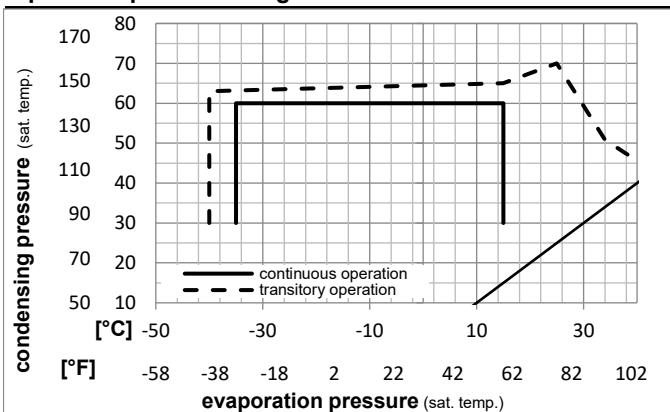

Components

a2	assy. relay	117U6003
c	start capacitor (80μF)	117U5017
d	cord relief	103N1004
b	plastic cover	103N2009

Model

Designation	SC12G	220-240V/50Hz	Conf. 1	Sales code:	104G8224
-------------	--------------	----------------------	----------------	-------------	-----------------

Optimization + standard conditions

R134a, 220V/50Hz, CSIR, fan 3m/s, CCC, VDE, KC

		Evaporating pressure (saturation temperature)				Condensing pressure (saturation temperature)			Return gas temp.			Liquid temp.			Cooling capacity			COP	EER	Power consumption			
		pe	pc	RGT	Tliq	[W]	[Btu/h]	[kcal/h]	[W/W]	[Btu/Wh]	[kcal/Wh]	P1	I	Ref. mass flow									
[°C]	[°F]											[W]	[A]	[kg/h]									
-23	-10	54	130	32	90	32	90	247,5	845	213,0	1,03	3,52	0,89	240,3	1,87	4,81							ASHRAE LBP
-7	20	54	130	35	95	46	115	615,0	2100	529,3	1,60	5,47	1,38	383,9	2,34	13,42							ASHRAE MBP
7,2	45	54	130	35	95	46	115	1170,4	3997	1007,3	2,29	7,81	1,97	511,8	2,84	25,97							ASHRAE HBP
-35	-31	40	104	20	68	40	104	123,3	421	106,1	0,75	2,55	0,64	165,0	1,73	2,70							EN12900 LBP
-10	14	45	113	20	68	45	113	547,2	1869	470,9	1,61	5,51	1,39	339,2	2,15	12,81							EN12900 MBP
5	41	50	122	20	68	50	122	994,8	3397	856,1	2,10	7,16	1,80	474,7	2,67	25,07							EN12900 HBP

Performance tables

R134a, 220V/50Hz, CSIR, fan 3m/s, CCC, VDE, KC

	pe		Cooling capacity			COP	EER	P1	I	m	
	[°C]	[°F]	[W]	[Btu/h]	[kcal/h]	[W/W]	[Btu/Wh]	[kcal/Wh]	[W]	[A]	[kg/h]
[°C / °F]	-35	-31	102,6	350	88,3	0,65	2,21	0,56	158,5	1,69	2,21
cond. pressure	-25	-13	234,7	802	202,0	1,03	3,51	0,89	228,1	1,84	5,09
pc= 45/113	-15	5	435,5	1487	374,8	1,44	4,93	1,24	301,4	2,03	9,49
return gas temp.	-10	14	567,7	1939	488,5	1,67	5,71	1,44	339,2	2,15	12,42
RGT= 32/90	0	32	907,8	3100	781,2	2,18	7,44	1,88	416,6	2,42	20,07
liquid temp	5	41	1120,5	3827	964,3	2,46	8,39	2,11	456,0	2,58	24,95
Tliq= 45/113	15	59	1643,6	5613	1414,5	3,07	10,48	2,64	535,5	2,93	37,23
[°C / °F]	-35	-31	64,6	221	55,6	0,44	1,49	0,38	147,9	1,63	1,54
cond. pressure	-25	-13	175,0	598	150,6	0,77	2,63	0,66	226,8	1,83	4,18
pc= 55/131	-15	5	348,0	1188	299,5	1,12	3,82	0,96	311,1	2,09	8,38
return gas temp	-10	14	464,1	1585	399,4	1,31	4,46	1,12	355,1	2,24	11,22
RGT= 32/90	0	32	767,6	2621	660,6	1,72	5,88	1,48	446,1	2,57	18,77
liquid temp	5	41	959,8	3278	826,0	1,95	6,65	1,68	493,0	2,76	23,65
Tliq= 55/131	15	59	1437,3	4909	1237,0	2,44	8,34	2,10	588,7	3,17	36,10

Model

Designation	SC12G	208-230V/60Hz	Conf. 2	Sales code:	104G8224
-------------	--------------	----------------------	----------------	-------------	-----------------

Configuration

Motorconfiguration	CSIR
Power supply (nominal)	208-230V/60Hz 1~
Refrigerant	R134a
Application	LBP
Voltage range	198-254V
Starting torque	HST
Approvals	CCC VDE KC

Electrical accessories / wiring diagram

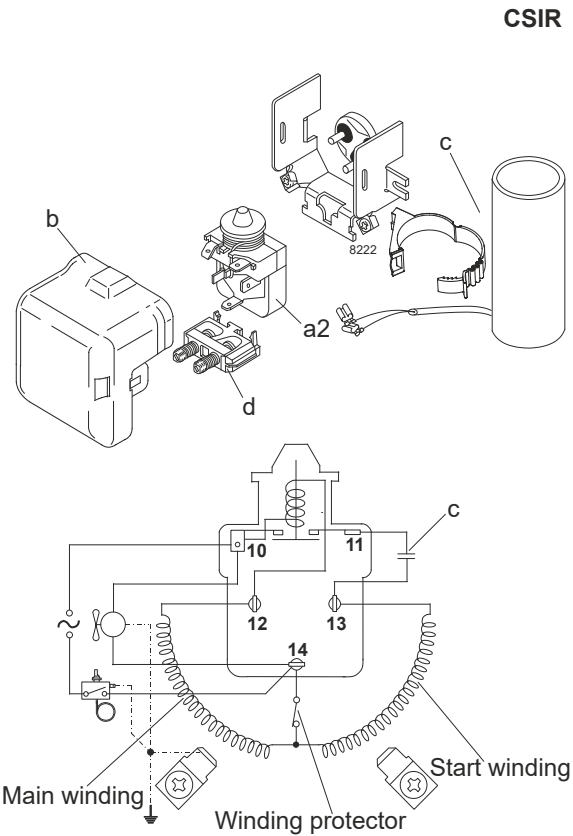

Ambient/ machine room temperatures minimum /maximum

Ambient temperature range:	10 - 43°C / 50 - 110°F
Machine room temperature range:	10 - 48°C / 50 - 119°F
Compressor cooling:	fan 3m/s

Operation Limits

Operation pressure range

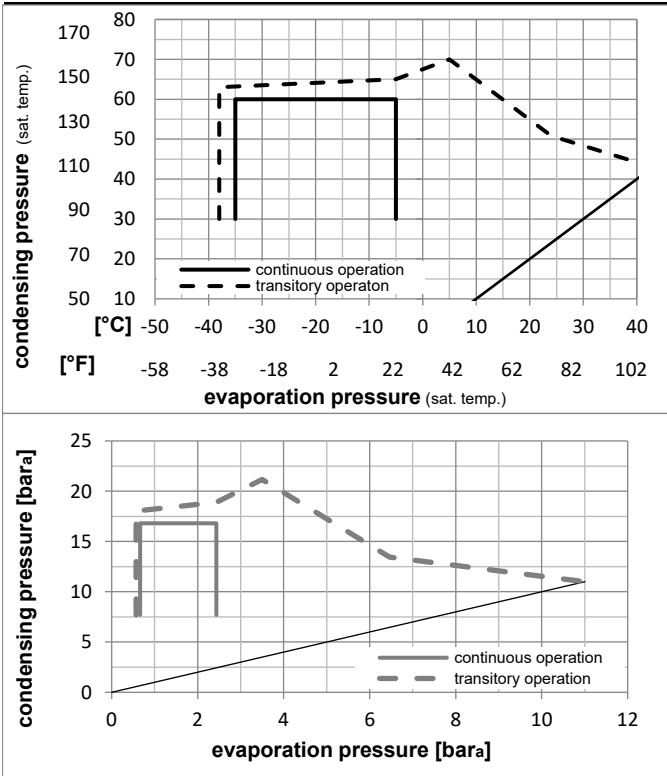

Components

a2	assy. relay	117U6003
c	start capacitor (80μF)	117U5017
d	cord relief	103N1004
b	plastic cover	103N2009

Model

Designation **SC12G** **208-230V/60Hz** Conf. 2 Sales code: **104G8224**

Optimization + standard conditions

R134a, 230V/60Hz, CSIR, fan 3m/s, CCC, VDE, KC

	Evaporating pressure (saturation temperature)				Condensing pressure (saturation temperature)			Return gas temp.	Liquid temp.	Cooling capacity	COP	EER	Power consumption			Ref. mass flow
	pe	pc	RGT	Tliq	[W]	[Btu/h]	[kcal/h]						P1	I	m	
[°C]																
[°F]																
	-23	54	32	32	288,0	983	247,8	1,03	3,51	0,88	280,6	2,06	5,59	ASHRAE LBP		
	-10	130	90	90												
	-7	54	35	46	718,1	2452	618,0	1,60	5,47	1,38	448,6	2,57	15,67	ASHRAE MBP		
	20	130	95	115												
	7,2	54	35	46	1367,9	4671	1177,2	2,29	7,81	1,97	598,1	3,12	30,35	ASHRAE HBP		
	45	130	95	115												
	-35	40	20	40	142,9	488	123,0	0,74	2,54	0,64	192,4	1,90	3,14	EN12900 LBP		
	-31	104	68	104												
	-10	45	20	45	638,9	2182	549,8	1,61	5,51	1,39	396,3	2,36	14,95	EN12900 MBP		
	14	113	68	113												
	5	50	20	50	1162,6	3970	1000,5	2,10	7,16	1,80	554,8	2,94	29,30	EN12900 HBP		
	41	122	68	122												

Performance tables

R134a, 230V/60Hz, CSIR, fan 3m/s, CCC, VDE, KC

	pe		Cooling capacity			COP	EER	P1	I	m	
	[°C]	[°F]	[W]	[Btu/h]	[kcal/h]	[W/W]	[Btu/Wh]	[kcal/Wh]	[W]	[A]	[kg/h]
[°C / °F]	-35	-31	118,7	405	102,2	0,64	2,19	0,55	184,8	1,86	2,56
cond. pressure	-30	-22	187,4	640	161,2	0,83	2,84	0,72	224,9	1,93	4,05
pc= 45/113	-25	-13	273,3	933	235,2	1,03	3,51	0,88	266,3	2,02	5,92
return gas temp.	-23	-10	306,9	1048	264,1	1,09	3,74	0,94	280,6	2,05	6,66
RGT= 32/90	-20	-4	379,3	1295	326,4	1,23	4,20	1,06	308,7	2,12	8,24
liquid temp	-15	5	508,2	1735	437,3	1,44	4,93	1,24	352,1	2,23	11,08
Tliq= 45/113	-5	23	846,1	2889	728,1	1,92	6,55	1,65	441,2	2,51	18,60
[°C / °F]	-35	-31	74,2	254	63,9	0,43	1,47	0,37	172,4	1,79	1,77
cond. pressure	-30	-22	131,0	448	112,8	0,60	2,06	0,52	217,7	1,89	3,13
pc= 55/131	-25	-13	203,3	694	175,0	0,77	2,62	0,66	264,7	2,01	4,86
return gas temp	-23	-10	232,0	792	199,6	0,83	2,82	0,71	281,0	2,06	5,55
RGT= 32/90	-20	-4	294,0	1004	253,0	0,94	3,20	0,81	313,3	2,15	7,05
liquid temp	-15	5	405,8	1386	349,2	1,12	3,81	0,96	363,4	2,30	9,77
Tliq= 55/131	-5	23	704,3	2405	606,1	1,51	5,14	1,30	467,5	2,64	17,12

Model

Designation	SC12G	220-240V/50Hz	Conf. 3	Sales code:	104G8224
-------------	--------------	----------------------	----------------	-------------	-----------------

Configuration

Motorconfiguration	RSIR
Power supply (nominal)	220-240V/50Hz 1~
Refrigerant	R134a
Application	LBP+MBP+HBP
Voltage range	187-254V
Starting torque	LST
Approvals	CCC VDE KC

Electrical accessories / wiring diagram

RSIR

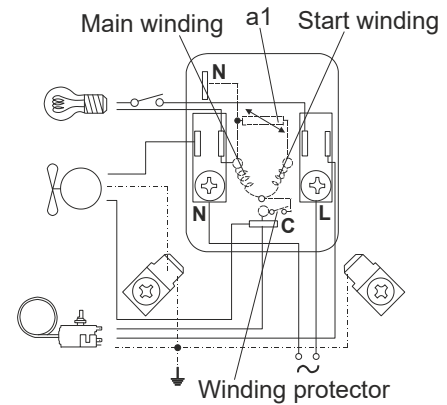
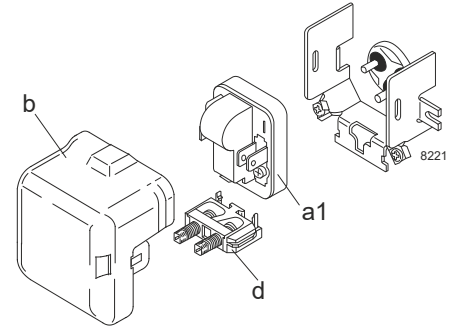

Ambient/ machine room temperatures minimum /maximum

Ambient temperature range:	10 - 43°C / 50 - 110°F
Machine room temperature range:	10 - 48°C / 50 - 119°F
Compressor cooling:	fan 3m/s

Operation Limits

Operation pressure range

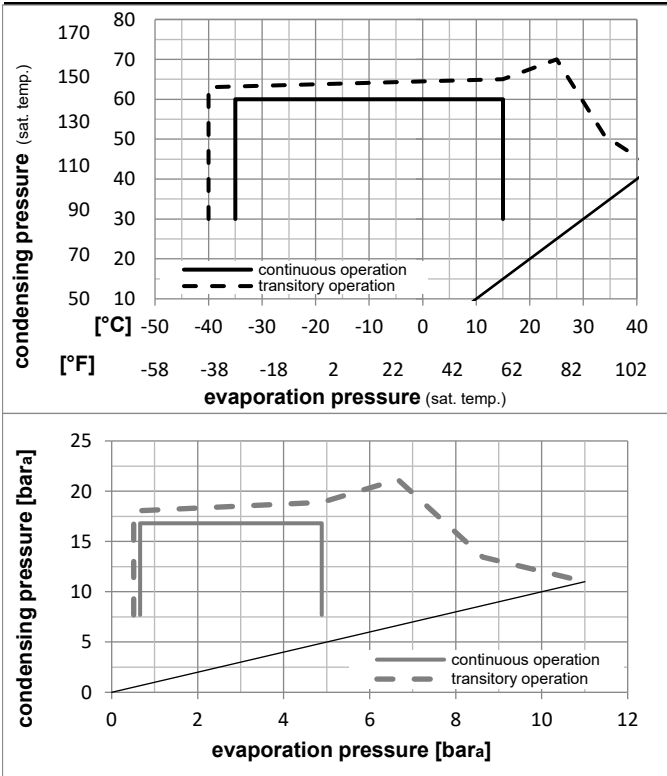

Components

a1	PTC starter (220V, 250hm, 6.3mm)	103N0011
d	cord relief	103N1004
b	plastic cover	103N2009

Model

Designation **SC12G** **220-240V/50Hz** Conf. 3 Sales code: **104G8224**

Optimization + standard conditions

R134a, 220V/50Hz, RSIR, fan 3m/s, CCC, VDE, KC

		Evaporating pressure (saturation temperature)			Condensing pressure (saturation temperature)			Return gas temp.			Liquid temp.			Cooling capacity			COP	EER	Power consumption			
		pe	pc	RGT	Tliq	[W]	[Btu/h]	[kcal/h]	[W/W]	[Btu/Wh]	[kcal/Wh]	P1	I	m								
[°C]	[°F]	[°C]	[°F]	[°C]	[°F]							[W]	[A]	[kg/h]								
-23	-10	54	130	32	90	247,5	845	213,0	1,03	3,52	0,89	240,3	1,87	4,81							ASHRAE LBP	
-7	20	54	130	35	95	615,0	2100	529,3	1,60	5,47	1,38	383,9	2,34	13,42							ASHRAE MBP	
7,2	45	54	130	35	95	1170,4	3997	1007,3	2,29	7,81	1,97	511,8	2,84	25,97							ASHRAE HBP	
-35	-31	40	104	20	68	123,3	421	106,1	0,75	2,55	0,64	165,0	1,73	2,70							EN12900 LBP	
-10	14	45	113	20	68	547,2	1869	470,9	1,61	5,51	1,39	339,2	2,15	12,81							EN12900 MBP	
5	41	50	122	20	68	994,8	3397	856,1	2,10	7,16	1,80	474,7	2,67	25,07							EN12900 HBP	

Performance tables

R134a, 220V/50Hz, RSIR, fan 3m/s, CCC, VDE, KC

	pe		Cooling capacity			COP	EER	P1			I	m
	[°C]	[°F]	[W]	[Btu/h]	[kcal/h]	[W/W]	[Btu/Wh]	[kcal/Wh]	[W]	[A]	[kg/h]	
[°C / °F]	-35	-31	102,6	350	88,3	0,65	2,21	0,56	158,5	1,69	2,21	
cond. pressure	-25	-13	234,7	802	202,0	1,03	3,51	0,89	228,1	1,84	5,09	
pc= 45/113	-15	5	435,5	1487	374,8	1,44	4,93	1,24	301,4	2,03	9,49	
return gas temp.	-10	14	567,7	1939	488,5	1,67	5,71	1,44	339,2	2,15	12,42	
RGT= 32/90	0	32	907,8	3100	781,2	2,18	7,44	1,88	416,6	2,42	20,07	
liquid temp	5	41	1120,5	3827	964,3	2,46	8,39	2,11	456,0	2,58	24,95	
Tliq= 45/113	15	59	1643,6	5613	1414,5	3,07	10,48	2,64	535,5	2,93	37,23	
[°C / °F]	-35	-31	64,6	221	55,6	0,44	1,49	0,38	147,9	1,63	1,54	
cond. pressure	-25	-13	175,0	598	150,6	0,77	2,63	0,66	226,8	1,83	4,18	
pc= 55/131	-15	5	348,0	1188	299,5	1,12	3,82	0,96	311,1	2,09	8,38	
return gas temp	-10	14	464,1	1585	399,4	1,31	4,46	1,12	355,1	2,24	11,22	
RGT= 32/90	0	32	767,6	2621	660,6	1,72	5,88	1,48	446,1	2,57	18,77	
liquid temp	5	41	959,8	3278	826,0	1,95	6,65	1,68	493,0	2,76	23,65	
Tliq= 55/131	15	59	1437,3	4909	1237,0	2,44	8,34	2,10	588,7	3,17	36,10	

Model

Designation	SC12G	208-230V/60Hz	Conf. 4	Sales code:	104G8224
-------------	--------------	----------------------	----------------	-------------	-----------------

Configuration

Motorconfiguration	RSIR
Power supply (nominal)	208-230V/60Hz 1~
Refrigerant	R134a
Application	LBP
Voltage range	198-254V
Starting torque	LST
Approvals	CCC VDE KC

Electrical accessories / wiring diagram

RSIR

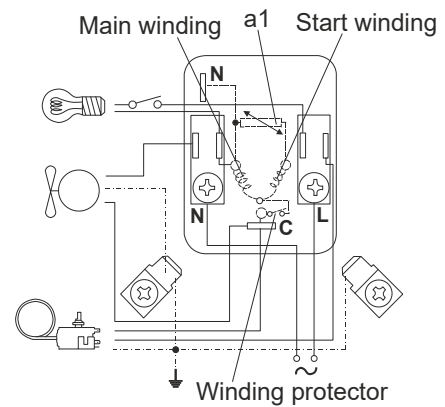
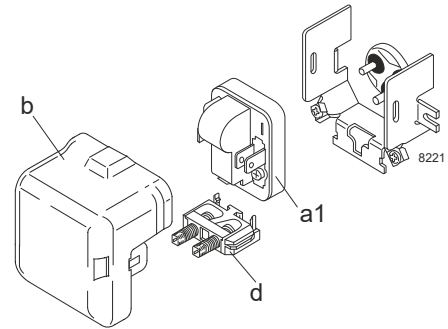

Ambient/ machine room temperatures minimum /maximum

Ambient temperature range:	10 - 43°C / 50 - 110°F
Machine room temperature range:	10 - 48°C / 50 - 119°F
Compressor cooling:	fan 3m/s

Operation Limits

Operation pressure range

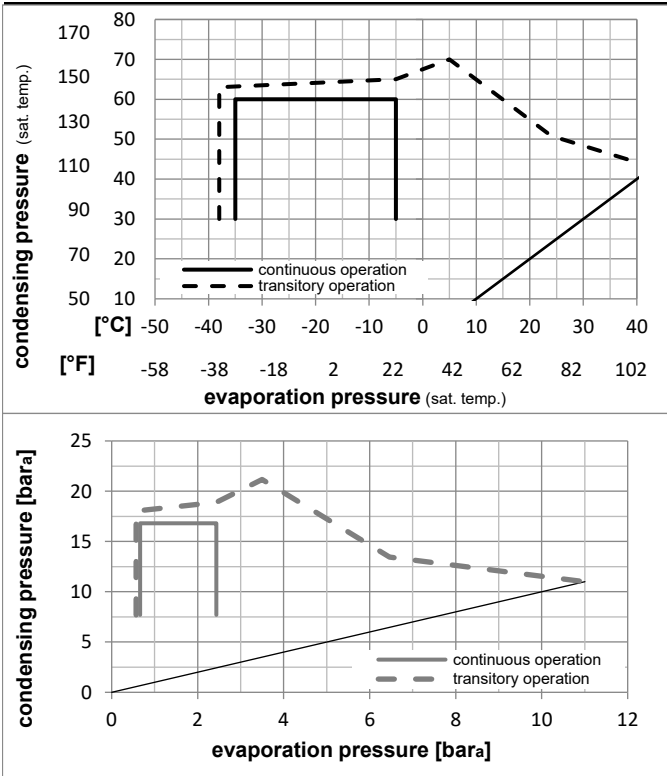

Components

a1	PTC starter (220V, 250hm, 6.3mm)	103N0011
d	cord relief	103N1004
b	plastic cover	103N2009

Model

Designation **SC12G** **208-230V/60Hz** Conf. 4 Sales code: **104G8224**

Optimization + standard conditions

R134a, 230V/60Hz, RSIR, fan 3m/s, CCC, VDE, KC

		Evaporating pressure (saturation temperature)				Condensing pressure (saturation temperature)						Power consumption			
		Return gas temp.		Liquid temp.		Cooling capacity		COP	EER		P1	I	Ref. mass flow		
		pe	pc	RGT	Tliq	[W]	[Btu/h]	[kcal/h]	[W/W]	[Btu/Wh]	[kcal/Wh]	[W]	[A]	[kg/h]	
[°C]	[°F]	[°C]	[°F]	[°C]	[°F]										
-23	54	32	32	288,0	983	247,8	1,03	3,51	0,88	280,6	2,06	5,59	ASHRAE LBP		
-10	130	90	90												
-7	54	35	46	718,1	2452	618,0	1,60	5,47	1,38	448,6	2,57	15,67	ASHRAE MBP		
20	130	95	115												
7,2	54	35	46	1367,9	4671	1177,2	2,29	7,81	1,97	598,1	3,12	30,35	ASHRAE HBP		
45	130	95	115												
-35	40	20	40	142,9	488	123,0	0,74	2,54	0,64	192,4	1,90	3,14	EN12900 LBP		
-31	104	68	104												
-10	45	20	45	638,9	2182	549,8	1,61	5,51	1,39	396,3	2,36	14,95	EN12900 MBP		
14	113	68	113												
5	50	20	50	1162,6	3970	1000,5	2,10	7,16	1,80	554,8	2,94	29,30	EN12900 HBP		
41	122	68	122												

Performance tables

R134a, 230V/60Hz, RSIR, fan 3m/s, CCC, VDE, KC

	pe		Cooling capacity			COP	EER	P1	I	m	
	[°C]	[°F]	[W]	[Btu/h]	[kcal/h]	[W/W]	[Btu/Wh]	[kcal/Wh]	[W]	[A]	[kg/h]
[°C / °F]	-35	-31	118,7	405	102,2	0,64	2,19	0,55	184,8	1,86	2,56
cond. pressure	-30	-22	187,4	640	161,2	0,83	2,84	0,72	224,9	1,93	4,05
pc= 45/113	-25	-13	273,3	933	235,2	1,03	3,51	0,88	266,3	2,02	5,92
return gas temp.	-23	-10	306,9	1048	264,1	1,09	3,74	0,94	280,6	2,05	6,66
RGT= 32/90	-20	-4	379,3	1295	326,4	1,23	4,20	1,06	308,7	2,12	8,24
liquid temp	-15	5	508,2	1735	437,3	1,44	4,93	1,24	352,1	2,23	11,08
Tliq= 45/113	-5	23	846,1	2889	728,1	1,92	6,55	1,65	441,2	2,51	18,60
[°C / °F]	-35	-31	74,2	254	63,9	0,43	1,47	0,37	172,4	1,79	1,77
cond. pressure	-30	-22	131,0	448	112,8	0,60	2,06	0,52	217,7	1,89	3,13
pc= 55/131	-25	-13	203,3	694	175,0	0,77	2,62	0,66	264,7	2,01	4,86
return gas temp	-23	-10	232,0	792	199,6	0,83	2,82	0,71	281,0	2,06	5,55
RGT= 32/90	-20	-4	294,0	1004	253,0	0,94	3,20	0,81	313,3	2,15	7,05
liquid temp	-15	5	405,8	1386	349,2	1,12	3,81	0,96	363,4	2,30	9,77
Tliq= 55/131	-5	23	704,3	2405	606,1	1,51	5,14	1,30	467,5	2,64	17,12

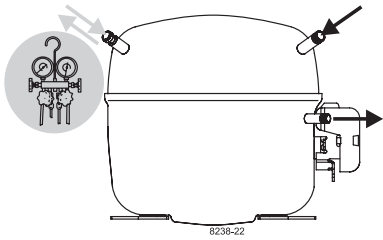

SC Compressors

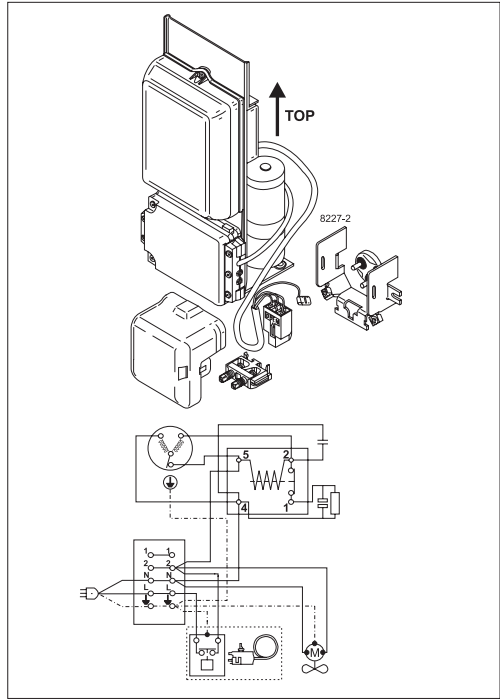
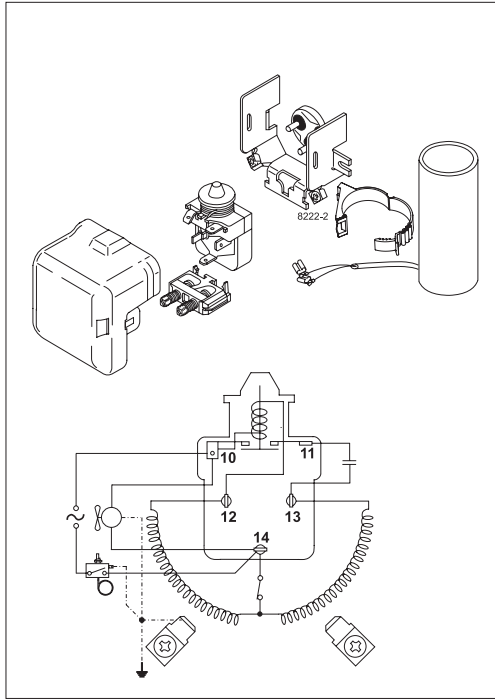
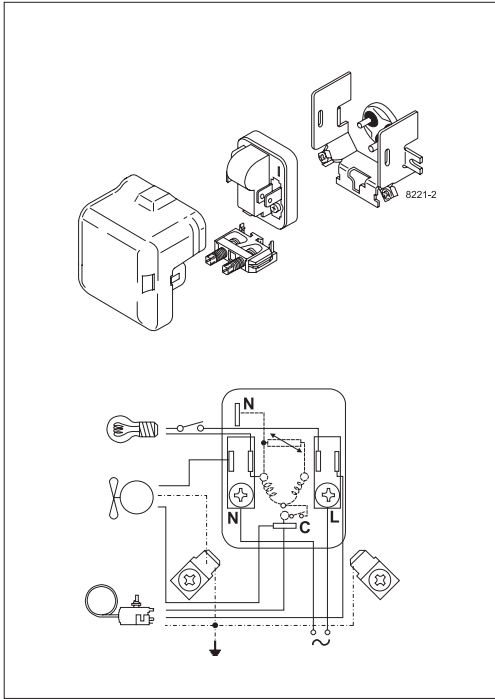

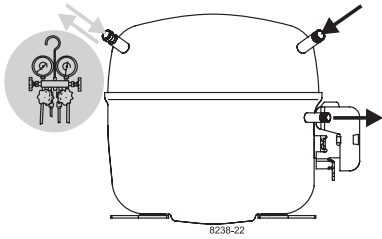

SC Compressors

Service/Repair – R290

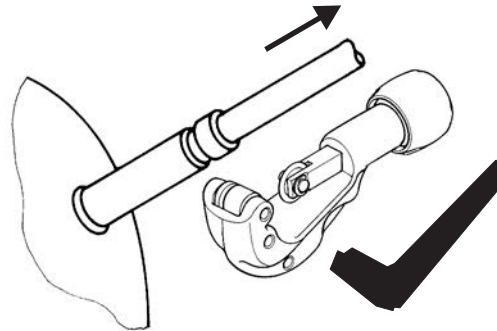
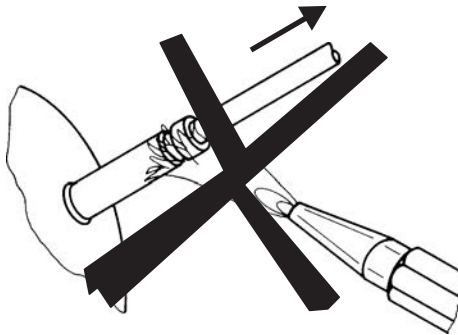

8545

Secop accepts no responsibility for possible errors in catalogs, brochures, and other printed material. Secop reserves the right to alter its products without notice. This also applies to products already on order provided that such alterations can be made without subsequent changes being necessary to specifications already agreed. All trademarks in this material are the property of the respective companies. Secop and the Secop logotype are trademarks of Secop GmbH. All rights reserved. www.secop.com