



XE Pump Series

Owner's Manual

Contents

Pump Warnings.....	2
Overview.....	5
Installation.....	6
Operation.....	9
Troubleshooting.....	14
Maintenance.....	15
Winterization.....	16
Shaft Seal Change.....	17
Replacement Parts.....	20

TriStar® XE
MaxFlo® XE
Super Pump® XE

Hayward Pool Products
1415 Vantage Park Dr., Suite 400
Charlotte, NC 28203
Phone (908)-355-7995
www.hayward.com



HAYWARD®

IMPORTANT SAFETY INSTRUCTIONS



Basic safety precautions should always be followed, including the following: Failure to follow instructions can cause severe injury and/or death.

⚠ This is the safety-alert symbol. When you see this symbol on your equipment or in this manual, look for one of the following signal words and be alert to the potential for personal injury.

⚠ WARNING warns about hazards that could cause serious personal injury, death or major property damage and if ignored presents a potential hazard.

⚠ CAUTION warns about hazards that will or can cause minor or moderate personal injury and/or property damage and if ignored presents a potential hazard. It can also make consumers aware of actions that are unpredictable and unsafe.

The **NOTICE** label indicates special instructions that are important but not related to hazards.

⚠ WARNING - Read and follow all instructions in this owner's manual and on the equipment. Failure to follow instructions can cause severe injury and/or death.

⚠ WARNING – This product should be installed and serviced only by a qualified professional.

⚠ CAUTION – All electrical wiring MUST be in conformance with all applicable local codes, regulations, and the National Electric Code (NEC).

USE OF NON-HAYWARD REPLACEMENT PARTS VOIDS WARRANTY.

ATTENTION INSTALLER - THIS MANUAL CONTAINS IMPORTANT INFORMATION ABOUT THE INSTALLATION, OPERATION, AND SAFE USE OF THIS VARIABLE SPEED PUMP THAT MUST BE FURNISHED TO THE END USER OF THIS PRODUCT. FAILURE TO READ AND FOLLOW ALL INSTRUCTIONS COULD RESULT IN SERIOUS INJURY.

⚠ WARNING – To reduce risk of injury, do not permit children to use or climb on this product. Closely supervise children at all times. Components such as the filtration system, pumps, and heaters must be positioned to prevent children from using them as a means of access to the pool.

⚠ CAUTION – This pump is intended for use on permanently installed swimming pools and may also be used with hot tubs and spas if so marked. Do NOT use with storable pools. A permanently installed pool is constructed in or on the ground or in a building such that it cannot be readily disassembled for storage. A storable pool is constructed so that it is capable of being readily disassembled for storage and reassembled to its original integrity. Though this product is designed for outdoor use, it is strongly advised to protect the electrical components from the weather. Select a well-drained area, one that will not flood when it rains. It requires free circulation of air for cooling. Do not install in a damp or non-ventilated location. If installed within an outer enclosure or beneath the skirt of a hot tub or spa, adequate ventilation and free circulation of air must be provided to prevent overheating of the motor.

For warranty information, please go to www.hayward.com/warranty.

SAVE THESE INSTRUCTIONS



⚠ WARNING – Pool and spa components (seals, gaskets, etc.) have a finite life. All components should be inspected frequently and replaced at least every ten years, or if found to be damaged, broken, cracked, missing, or not securely attached.



⚠ WARNING – Risk of Electric Shock. All electrical wiring **MUST** be in conformance with applicable local codes, regulations, and the National Electric Code (NEC). Hazardous voltage can shock, burn, and cause death or serious property damage. To reduce the risk of electric shock, do **NOT** use an extension cord to connect unit to electric supply. Provide a properly located electrical receptacle. Before working on pump or motor, turn off power supply to the pump.

⚠ WARNING – To reduce the risk of electric shock replace damaged wiring immediately. Locate conduit to prevent abuse from lawn mowers, hedge trimmers and other equipment.

⚠ WARNING – Risk of Electric Shock. In accordance with the National Electric Code (NEC), connect only to a branch circuit protected by a ground-fault circuit-interrupter (GFCI). Contact a qualified electrician if you cannot verify that the circuit is protected by a GFCI. The unit must be connected only to a supply circuit that is protected by a ground-fault circuit-interrupter (GFCI). Such a GFCI should be provided by the installer and should be tested on a routine basis. To test the GFCI, push the test circuit button. The GFCI should interrupt power. Push the reset button. Power should be restored. If the GFCI fails to operate in this manner, the GFCI is defective. If the GFCI interrupts power to the pump without the test button being pushed, a ground current is flowing, indicating the possibility of an electric shock. Do not use this pump. Disconnect the pump and have the problem corrected by a qualified service representative before using.

⚠ WARNING – Failure to bond pump to pool structure will increase risk for electrocution and could result in injury or death. To reduce the risk of electric shock, see installation instructions and consult a professional electrician on how to bond pump. Also, contact a licensed electrician for information on local electrical codes for bonding requirements.

Notes to electrician: Use a solid copper conductor, size 8 or larger. Run a continuous wire from external bonding lug to reinforcing rod or mesh. Connect a No. 8 AWG (8.4 mm²) [No. 6 AWG (13.3 mm²) for Canada] solid copper bonding wire to the pressure wire connector provided on the pump housing and to all metal parts of swimming pool, spa, or hot tub, and to all electrical equipment, metal piping (except gas piping), and conduit within 5 ft. (1.5 m) of inside walls of swimming pool, spa, or hot tub. **IMPORTANT** - Reference NEC codes for all wiring standards including, but not limited to, grounding, bonding and other general wiring procedures.

⚠ WARNING – Suction Entrapment Hazard. Suction in suction outlets and/or suction outlet covers, which are damaged, broken, cracked, missing, or unsecured cause severe injury and/or death due to the following entrapment hazards (symbols complements of APSP):



Hair Entrapment - Hair can become entangled in suction outlet cover.

Limb Entrapment - A limb inserted into an opening of a suction outlet sump or suction outlet cover that is damaged, broken, cracked, missing, or not securely attached can result in a mechanical bind or swelling of the limb.



Body Suction Entrapment - A differential pressure applied to a large portion of the body or limbs can result in an entrapment.



Evisceration/ Disembowelment - A negative pressure applied directly to the intestines through an unprotected suction outlet sump or suction outlet cover which is damaged, broken, cracked, missing, or unsecured can result in evisceration/disembowelment.



Mechanical Entrapment - There is potential for jewelry, swimsuits, hair decorations, fingers, toes, or knuckles to be caught in an opening of a suction outlet cover resulting in mechanical entrapment.



▲ WARNING – To Reduce the risk of Entrapment Hazards:



- When outlets are small enough to be blocked by a person, a minimum of two functioning suction outlets per pump must be installed. Suction outlets in the same plane (i.e. floor or wall), must be installed a minimum of three feet (3') [0.91 meter] apart, as measured from near point to near point.
- Dual suction fittings shall be placed in such locations and distances to avoid “dual blockage” by a user.
- Dual suction fittings shall not be located on seating areas or on the backrest for such seating areas.
- The maximum system flow rate shall not exceed the values shown in the “Pipe Sizing Chart” found in section 4.3 below.
- Never use pool or spa if any suction outlet component is damaged, broken, cracked, missing, or not securely attached.
- Replace damaged, broken, cracked, missing, or not securely attached suction outlet components immediately.
- In addition to two or more suction outlets per pump installed in accordance with latest APSP standards and CPSC guidelines, follow all national, state, and local codes applicable.
- Installation of a vacuum release or vent system, which relieves entrapping suction, is recommended.



▲ WARNING – Hazardous Pressure. Pool and spa water circulation systems operate under hazardous pressure during start-up, normal operation, and after pump shut-off. Stand clear of circulation system equipment during pump start-up. Failure to follow safety and operation instructions could result in violent separation of the pump housing and cover due to pressure in the system, which could cause property damage, severe personal injury, or death. Before servicing pool and spa water circulation system, all system and pump controls must be in off position and filter manual air relief valve must be in open position. Before starting pump, all system valves must be set in a position to allow system water to return back to the pool. Do not change filter control valve position while pump is running. Before starting pump, fully open filter manual air relief valve. Do not close filter manual air relief valve until a steady stream of water (not air or air and water mix) is discharged from the valve. All suction and discharge valves **MUST** be OPEN when starting the circulation system. Failure to do so could result in severe personal injury and/or property damage.



▲ WARNING – Separation Hazard. Failure to follow safety and operation instructions could result in violent separation of pump components. Strainer cover must be properly secured to pump housing with strainer cover lock ring. Before servicing pool and spa circulation system, all system and pump controls must be in off position and filter manual air relief valve must be in open position. Do not operate pool and spa circulation system if a system component is not assembled properly, damaged, or missing. Do not operate pool and spa circulation system unless filter manual air relief valve body is in locked position in filter upper body. All suction and discharge valves **MUST** be OPEN when starting the circulation system. Failure to do so could result in severe personal injury and/or property damage.

▲ WARNING – Never operate the circulation system at more than 50 PSI maximum.

▲ WARNING – Fire and burn hazard. Motors operate at high temperatures and if they are not properly isolated from any flammable structures or foreign debris they can cause fires, which may cause severe personal injury or death. It is also necessary to allow the motor to cool for at least 20 minutes prior to maintenance to minimize the risk for burns.

▲ WARNING – Failure to install according to defined instructions may result in severe personal injury or death.

SAVE THESE INSTRUCTIONS

Overview

This manual contains information for the proper installation and operation of the Hayward XE variable speed pump family and MUST be followed precisely.

Product Dimensions

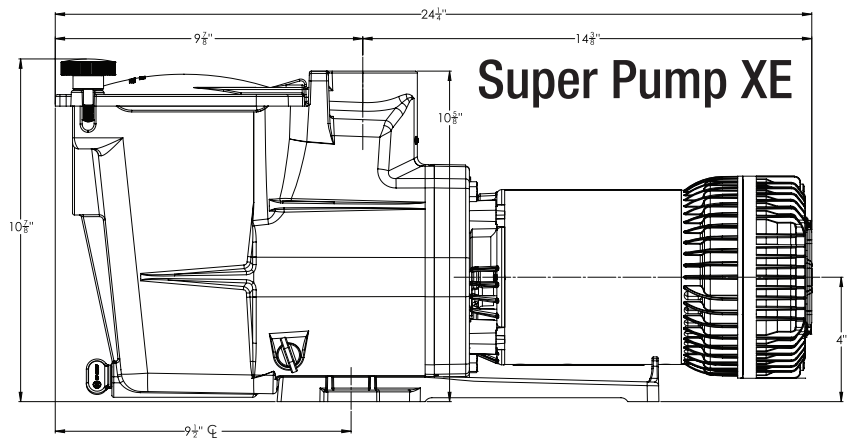
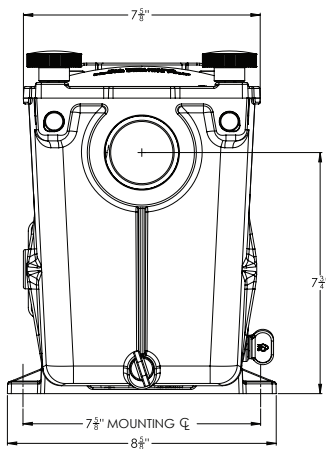
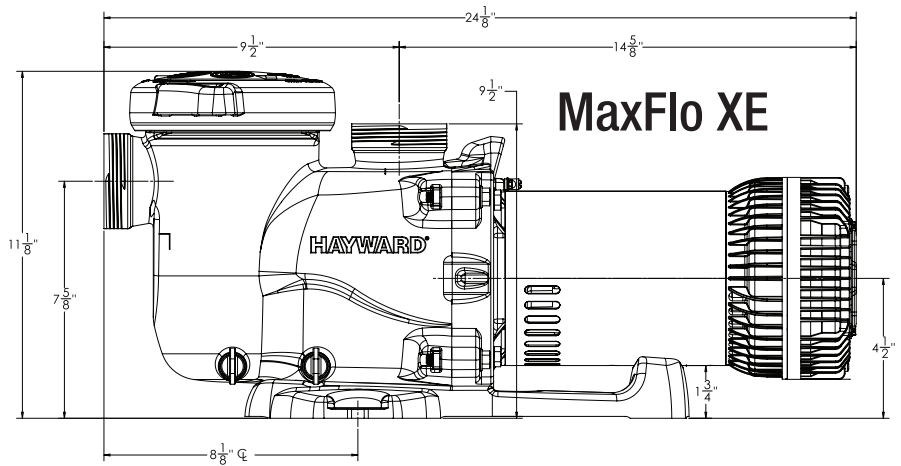
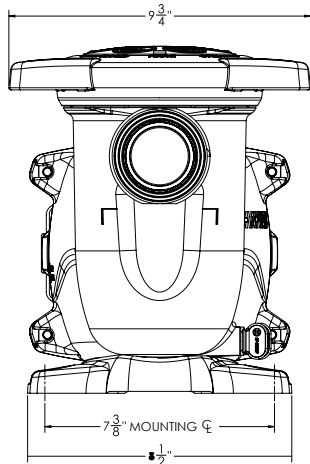
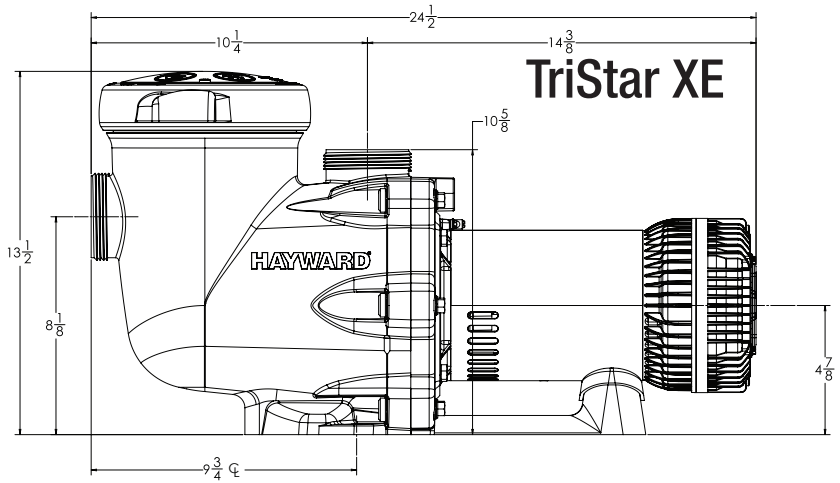
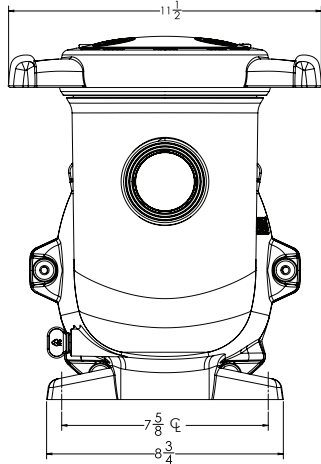

Installation

Pump Location

Locate pump as close to the pool as possible, in compliance with local codes. To reduce friction loss, suction lines should be as direct as they can be. Suction lines should have continuous slope upward from lowest point in line. Joints must be tight (but not over-tightened). Suction line diameter must equal or be larger than the discharge line diameter.

Though the pump is designed for outdoor use, it is advised to place pump and filter in the shade to shield them from continuous direct heat. Select a well-drained area that will not flood when it rains. Do NOT install pump and filter in a damp or non-ventilated location. Keep motor clean. Pump motors require free circulation of air for cooling.

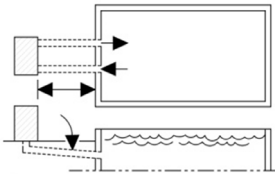

Pump Mounting

Install pump on a level concrete slab or other rigid base to meet all local and national codes. Secure pump to base with screws or bolts to further reduce vibration and stress on pipe or hose joints. The base must be level, rigid, and vibration free.

Pump mount must:

- Allow pump inlet height to be as close to water level as possible.
- Allow use of short, direct suction pipe (to reduce friction losses).
- Allow for valves in suction and discharge piping.
- Be protected from excess moisture and flooding.
- Allow adequate access for servicing pump and piping.

Pipe Sizing Chart

MAXIMUM RECOMMENDED SYSTEM FLOW RATE BY PIPE SIZE		
Pipe Size in. [mm]	Maximum Flow Rate GPM [LPM]	Minimum Straight Pipe Length "L" in. [mm] *
1 1/2" [50]	45 [170]	7 1/2" [190]
2" [63]	80 [300]	10" [254]
2 1/2" [75]	110 [415]	12 1/2" [317]
3" [90]	160 [600]	15" [381]

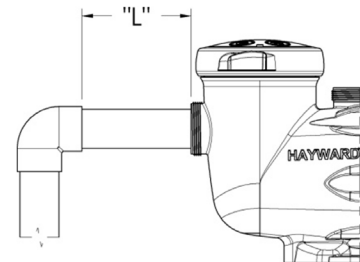

Note: It is recommended that a minimum length of straight piping (shown as "L" in above diagram), equivalent to 5 pipe size diameters, be used between the pump suction inlet and any plumbing fittings (elbows, valves, etc.).

When installing the XE pump, care should be taken to ensure proper pipe and equipment sizing to handle the maximum flow required. It is recommended to set the maximum speed in order to not exceed the maximum flow rate.

⚠ WARNING – Hazardous Pressure. Pumps, filters, and other equipment/ components of a swimming pool filtration system operate under pressure. Incorrectly installed and/or improperly tested filtration equipment and/or components may fail resulting in severe personal injury or death.



Plumbing

1. Use PTFE tape to seal threaded connections on molded plastic components. All plastic fittings must be new or thoroughly cleaned before use. NOTE - Do NOT use Plumber's Pipe Dope as it may cause cracking of the plastic components. When applying PTFE tape to plastic threads, wrap the entire threaded portion of the male fitting with one to two layers of tape. Wind the tape clockwise as you face the open end of the fitting, beginning at the end of the fitting. The pump suction and outlet ports have molded-in thread stops. Do NOT attempt to force hose connector fitting past this stop. It is only necessary to tighten fittings enough to prevent leakage. Tighten fitting by hand and then use a tool to engage fitting an additional 1 ½ turns. Use care when using PTFE tape as friction is reduced considerably; do NOT over-tighten fitting or you may cause damage. If leaks occur, remove connector, clean off old PTFE tape, re-wrap with one to two additional layers of PTFE tape, and re-install connector.
2. Fittings (elbows, tees, valves, etc.) restrict flow. For better efficiency, use the fewest possible fittings. Avoid fittings that could cause an air trap. Pool and spa fittings MUST conform to the International Association of Plumbing and Mechanical Officials (IAPMO) standards.

Electrical

⚠ WARNING – All electrical wiring MUST conform to local codes, regulations, and the National Electric Code (NEC).

⚠ WARNING – Ground and bond pump before connecting to electrical power supply. Failure to ground and bond pump can cause serious or fatal electrical shock hazard. Do NOT ground to a gas supply line. To avoid dangerous or fatal electrical shock, turn OFF power to pump before working on electrical connections. Fire Hazard - match supply voltage to pump nameplate voltage. Insure that the electrical supply available agrees with the pump's voltage, phase, and cycle, and that the wire size is adequate for the amps rating and distance from the power source. Use copper conductors only.



Electrical Specs

Refer to motor nameplate for voltage and current ratings. Use copper conductors only. For indoor & outdoor use. Connect pump to an appropriately sized/rated branch circuit protector in accordance with local codes, regulations, and the National Electric Code (NEC). A disconnecting means located at least 5 ft. from the inside wall of the pool, spa, or hot tub must be provided.

Voltage

Voltage at pump MUST NOT be more than 10% above or below nameplate rated voltage, or components may overheat, causing overload tripping and reduced component life. If voltage is less than 90% or more than 110% of rated voltage when pump is running at full load, consult the power company.

Grounding and Bonding

1. Install, ground, bond, and wire pump in accordance with local or national electrical code requirements.
2. Permanently ground pump. Use green ground terminal provided under access plate; use size and type wire required by code. Connect ground terminal to electrical service ground.
3. Bond pump to pool structure. Bonding will connect all metal parts within and around the pool with a continuous wire. Bonding reduces the risk of a current passing between bonded metal objects, which could potentially cause electrical shock if grounded or shorted. Reference NEC codes for all wiring standards including, but not limited to, grounding, bonding and general wiring procedures.
4. Use a solid copper conductor, size 8 or larger. Run wire from external bonding lug to reinforcing rod or mesh. Connect a No. 8 AWG (8.4 mm²) [No. 6 AWG (13.3 mm²) for Canada] solid copper bonding wire to the pressure wire connector provided on the motor housing and to all metal parts of swimming pool, spa, or hot tub, and to all electrical equipment, metal piping (except gas piping), and conduit within 5 ft. (1.5 m) of inside walls of swimming pool, spa, or hot tub.

Input Power

⚠ WARNING – All electrical wiring MUST conform to local codes, regulations, and National Electric Code (NEC).

Pump MUST be permanently connected to circuit. Connect pump to an appropriately sized/rated branch circuit protector in accordance with local codes, regulations, and the National Electric Code (NEC). Use the circuit breaker as the master On-Off switch.

Wiring Connections

1. TURN OFF THE ELECTRICAL POWER AT THE CIRCUIT BREAKER.
2. Loosen the four screws securing the wiring compartment cover and remove the cover to gain access to the drive wiring compartment.
3. Move the selectable input voltage jumper to the appropriate position as shown below (comes set for 230 VAC from the factory). Pull the jumper straight up off the connector to disconnect. Connect line power supply wiring to the appropriate terminals. Connect ground wiring to the ground screw. Exit wiring must be routed through the conduit using proper watertight fittings.

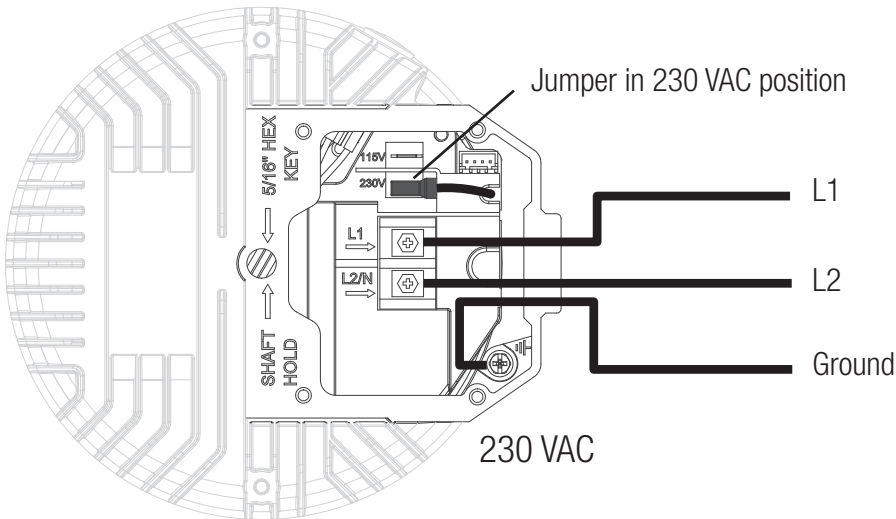

ATTENTION: ROUTE WIRING DIRECTLY FROM FIELD CONDUIT TO TERMINAL BLOCK AS SHOWN. DO NOT BUNDLE EXCESS WIRING INSIDE DRIVE ENCLOSURE.

- USE COPPER CONDUCTORS ONLY
- ACCEPTABLE FOR FIELD WIRING
- NOT SUITABLE FOR USE WITH RIGID METAL CONDUIT
- REMOVE TEST LEADS PRIOR TO INSTALL

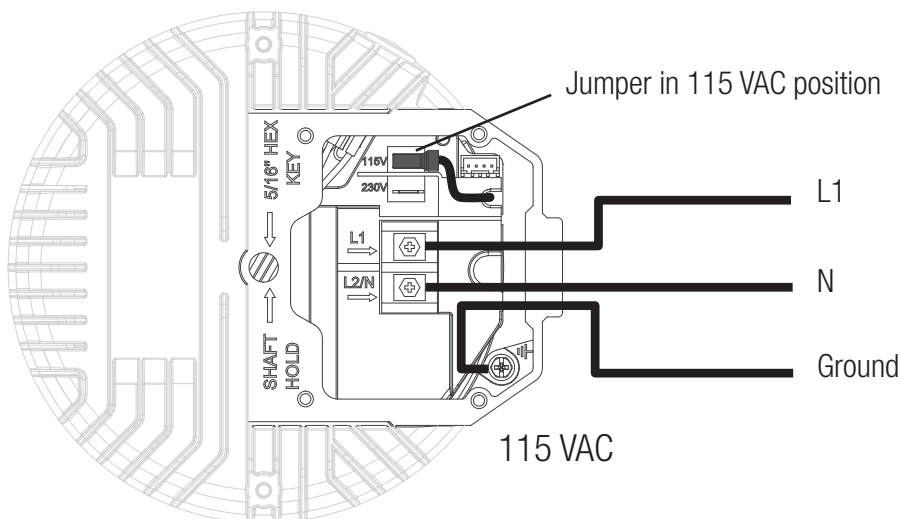

4. Connect the pump to the pool bonding system as described on page 7. A lug for bonding is provided on the top of the motor.
5. After all electrical connections have been made, replace the wiring compartment cover, taking care to make sure it is properly aligned with the motor drive. Tighten the four screws to secure. Note: The wiring compartment cover must be installed properly to provide environmental protection for the wiring compartment.



Operation

Prior to Start-Up

If it is necessary to perform a water pressure test prior to initial use to ensure plumbing system is functioning properly, then the following criteria should be maintained for this test:

1. Have a professional perform this test.
2. Ensure all Hayward pump and system components are removed from system prior to performing test.

⚠ WARNING – If circulation equipment must remain in the plumbing system during water pressure test, do not apply more than 10 psi pressure to the system. Be sure water pressure has been released, using the filter manual air relief valve, before removing pump strainer cover.

⚠ WARNING – All suction and discharge valves **MUST** be OPEN, as well as filter air relief valve (if available) on filter, when starting the circulating pump system. Failure to do so could result in severe personal injury.

Starting/Priming the Pump

Fill strainer housing with water to suction pipe level. If water leakage occurs from anywhere on the pump or filter, **DO NOT** start the pump. If no leakage occurs, stand at least 10 feet from pump and/or filter and proceed with starting the pump. To start the pump for priming, use Manual Override described in the Pump Control and Programming section below.

⚠ WARNING – Return to filter to close filter manual air relief valve when a steady stream of water (not air or air and water) is discharged from valve. Failure to do so could result in severe personal injury.

⚠ ATTENTION – NEVER OPERATE THE PUMP WITHOUT WATER. Water acts as a coolant and lubricant for the mechanical shaft seal. NEVER run pump dry. Running pump dry may damage seals, causing leakage, flooding, and voids warranty. Fill strainer housing with water before starting motor.

⚠ ATTENTION – Do NOT add chemicals to pool/spa system directly in front of pump suction. Adding undiluted chemicals may damage pump and voids warranty.

⚠ ATTENTION – Before removing strainer cover:

1. STOP PUMP before proceeding.
2. CLOSE VALVES in suction and outlet pipes.
3. RELEASE ALL PRESSURE from pump and piping system using filter manual air relief valve. See filter owner’s manual for more details.
4. Remove strainer cover and fill strainer housing with water.
5. Clean and lubricate strainer cover O-ring with “Jack’s 327” if necessary.
6. Replace strainer cover on strainer housing.
7. OPEN VALVES in suction and outlet pipes.

Note: Tighten strainer cover (lock ring or hand knobs) by hand only. Do not use tools or wrenches.

Turn on power and wait for pump to prime, which can take up to ten (10) minutes. Priming time will depend on vertical length of suction lift and horizontal length of suction pipe. If pump does NOT prime within 10 minutes, stop motor and determine cause. Be sure all suction and discharge valves are open when pump is running. See Troubleshooting Guide.

Pump Control and Programming

The XE Pump user interface consists of a single push button with an LED indicator ring as shown below.

The push button allows the user to:

- Program the daily schedule
- Enter Manual Override mode
- Clear motor/drive errors

Button function quick reference:

Operating Mode	Button Press	Action
Normal Operation	Quick Press	Start manual override
	Press and hold 4 seconds	Start programming mode
Manual Override	Quick Press	Change manual override speeds
	Press and Hold 4 seconds	Exit manual override



The LED indicator communicates operating mode and pump status.

Operating Mode or Status	LED Behavior
Normal Operation	Solid Green
Manual Override	Slow Flashing ON/OFF
Programming – Interval 1	Quick Flashing - One Blink
Programming – Interval 2	Quick Flashing - Two Blinks
Programming – Interval 3	Quick Flashing - Three Blinks
Press & Hold Confirmation	Three Rapid Flashes
System Errors	See Table on page 15

Operating Speeds

There are six speeds available on the XE pumps. When programming the Daily Schedule (page 11), refer to this information.



Normal Operation – The Daily Schedule

The XE pump will operate on a 24 hour daily schedule which runs continuously and restarts every 24 hours. This 24 hour schedule is split into 3 time intervals which are each programmable to one of several different speeds. The default schedule from the factory is shown below:

24 Hour Daily Schedule - Default			
	Interval 1	Interval 2	Interval 3
Duration	4 Hours	8 Hours	12 Hours
Speed	50%	50%	50%

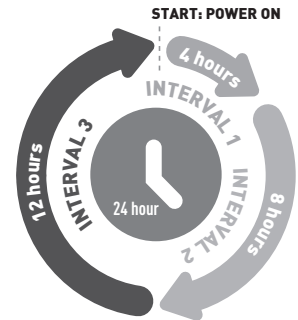

To prime the system, the pump will run for 8 minutes at maximum speed whenever power is first applied.

The daily schedule starts as soon as power is applied to the pump. After priming, the pump will run at the speed programmed in Interval 1 for four hours, and then it will change to the speed programmed in Interval 2 for eight hours, and finally the speed of Interval 3 for twelve hours. After the end of Interval 3, the pump will return to the start of Interval 1. This daily schedule will run continuously until power is removed from the pump.

In order to ensure the pump operates throughout the day at the desired speed, apply power to the pump at a time suitable for the application.

If it is desired that the pump run at 50% at all times, apply power to the pump and use the default schedule. If different speeds are desired, program the daily schedule as shown on page 11.

Important: Any time power is removed and re-applied to the pump, such as turning off a switch or breaker, the pump will restart the daily schedule at the beginning of Interval 1. The start of the daily schedule will always be the time at which power is applied to the pump. Note that when power is removed from the pump, the LED will blink for a short period and you must wait for the LED to fully turn off before reapplying power. This may take up to 30 seconds. If power is applied while the LED is still blinking, the motor will not start for 6 minutes. This delay can be overridden if the button is pressed.

Programming the Daily Schedule

The daily 24 hour schedule can be programmed using the push button on the motor drive housing. Each of the three time intervals can be programmed to one of the pump's available speeds. In the programming information and diagrams below, they are represented as "Speed 1, Speed 2, etc.", moving from fastest to slowest. "STOP" is also a selection if you want the pump be off during an interval. Note that exact pump speeds may vary due to input voltage and system conditions.

- Speed 1 (fastest)
- Speed 2
- Speed 3
- Speed 4
- Speed 5
- Speed 6 (slowest)
- STOP

Programming the pump follows a simple process of pressing the button to cycle through available speeds (from fastest to slowest), and pressing and holding the button to save the speed to a given interval. An overview is shown below.

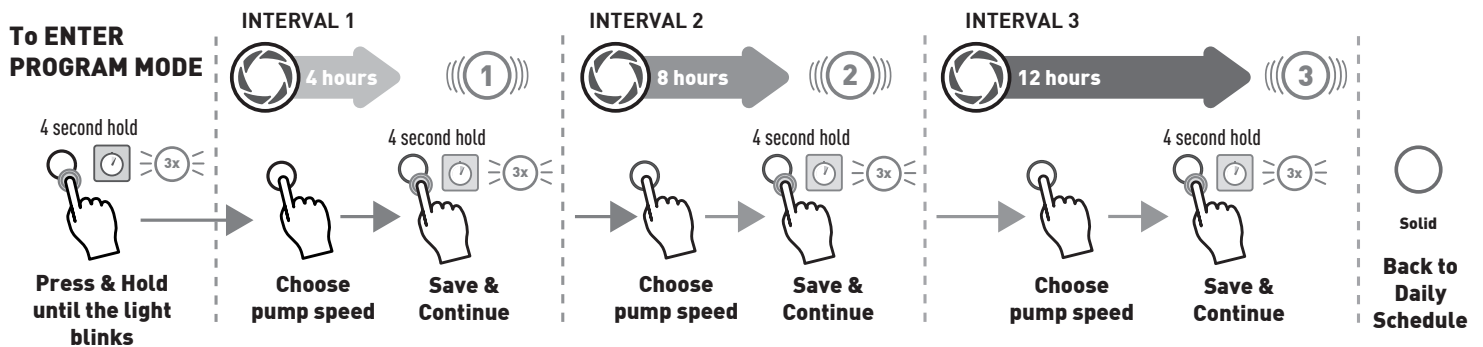

Detailed Programming Procedure

1. While power is applied to the pump, press and hold the button for 4 seconds. When the button has been held long enough, the LED ring will rapidly flash 3 times, at which point the button may be released and the pump will enter programming mode.

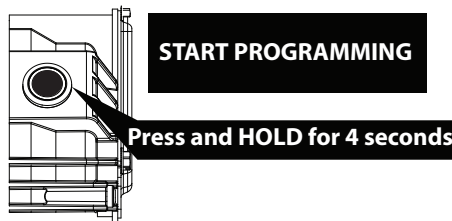

2. Once in programming mode, the LED ring will communicate which interval is being programmed. The first interval is Interval 1, and the LED ring will repeatedly flash one time, followed by a pause.
3. To save a speed to Interval 1:
 - a. Adjust the speed of the pump to the desired speed by pressing the button. The first press always brings you to maximum speed (Speed 1=100%) and each press after will decrease the speed until it reaches STOP and then the cycle will repeat. Refer to the diagram below.

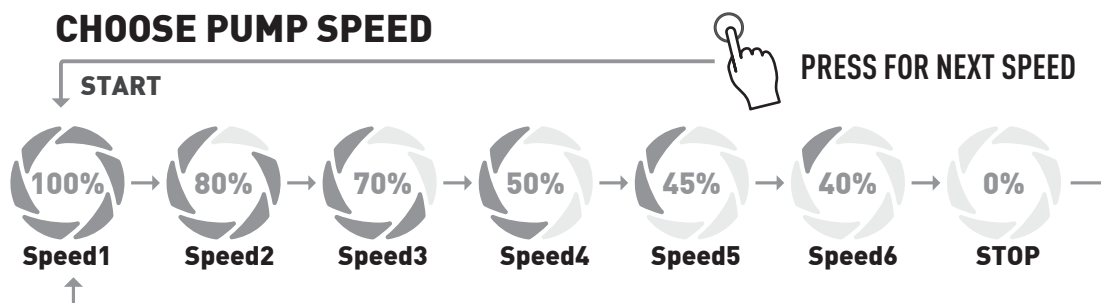

- b. Once the desired speed is reached, press and hold the button for 4 seconds to save the speed. The LED will flash 3 times to confirm.

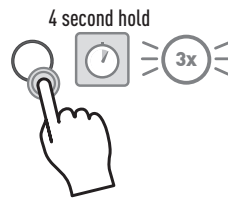

Press & Hold

4. After saving a speed to Interval 1, the process will continue for programming Interval 2. The LED ring will repeatedly flash twice followed by a pause to indicate that the user is currently programming Interval 2.
 - a. The initial speed for Interval 2 will be the speed that was programmed for Interval 1. If this is desired, press and hold for 4 seconds. If not, follow the same procedure as step three to cycle through the available speeds, first press brings you to Speed 1, each additional press advances until the desired speed is reached. Press and hold the button for 4 seconds to save the desired speed to Interval 2.
5. Once Interval 2 has been saved, programming mode will continue to the last interval and the LED will repeatedly flash 3 times followed by a pause to indicate that the user is currently programming Interval 3.
 - a. The initial speed for Interval 3 will be the speed that was programmed for Interval 2. If this is desired, press and hold for 4 seconds. If not, follow the same procedure as above. Once a speed has been selected, press and hold the button for 4 seconds to save the speed to Interval 3.
 - b. Once Interval 3 has been saved, the pump will exit programming mode and will restart.
 - c. The pump will be stopped for a few seconds while it restarts.
6. After the pump has restarted, the new schedule will take effect.
7. The new schedule will retain the same 24 hour cycle as the previous schedule.
 - a. Example: if the previous schedule started at 8:00AM, the new schedule will also start at 8:00AM regardless of when the programming occurred.
 - b. If the desire is to change the start time of the schedule, simply remove and reapply power to the pump using a switch or breaker. The schedule will then start from when power was reapplied to the pump.

Example Program

Desired schedule starting at 8:00AM every day (apply power at 8:00AM to start program) - 80% for 4 hours, 40% for 8 hours and OFF for 12 hours

80% for 4 hours / 40% for 8 hours / 0% for 12 hours

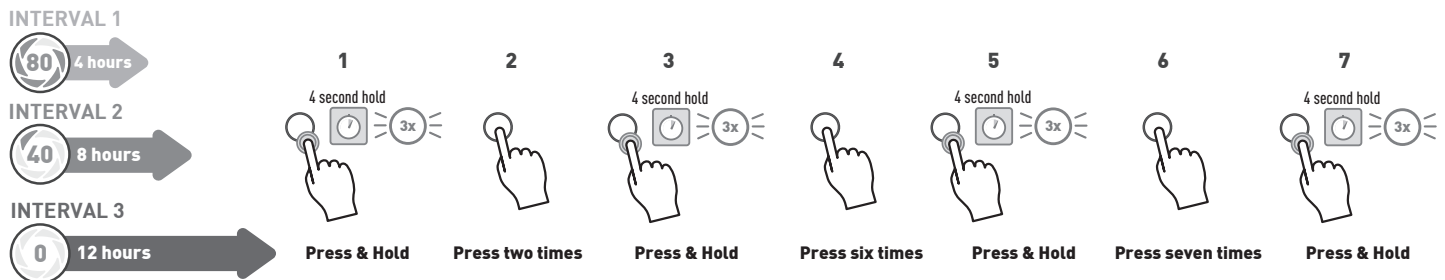

Important: If power is lost/removed from the pump during programming, any changes made to the schedule will not be saved. While in programming mode, if no commands are entered by using the button within 2 minutes, then the pump will default to normal operation. In this case, any change made to the schedule WILL be saved.

For the schedule to start at 8:00AM, remove and reapply power at 8:00AM.



Manual Override

During normal operation, the pump speed can be manually overridden for 3 hours by a quick press and release of the button.

OVERRIDE MODE - 3 hours



Manual Override Speeds

There are 3 speeds available in manual override mode:

- HIGH
- MED
- LOW
- STOP

To cycle through the speeds press the button additional times while in override mode. Manual override mode will always start at HIGH.

Note: Initiating override mode will not change the start time for the daily schedule. While in override mode, the pump will operate at a single speed for 3 hours and then will revert back to normal operation according to the daily schedule. This does not apply to the STOP function and the pump will remain stopped until manual override is cancelled or a manual override speed is selected.

Manual Override Example

If the daily schedule started at 8:00AM, and the daily schedule was Speed 1 - 4 hours, Speed 3 - 8 hours, and STOP - 12 hours. Pressing the button for manual override at 7:00PM would result in a 3 hour override from 7:00PM-10:00PM and when completed, the schedule would resume in Interval 3, which is programmed as STOP. The start of the daily schedule remains at 8:00AM.

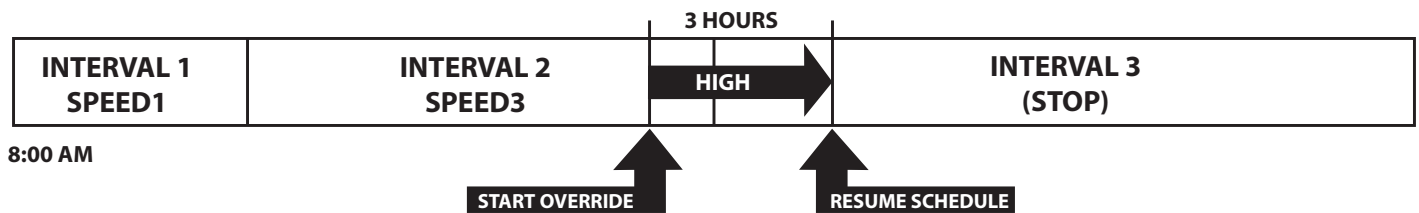

The manual override mode can also be canceled by pressing and holding the button for 4 seconds while override mode is active. This will cause the pump to resume the daily schedule in the same manner as if the manual override expired.

Changing between Operating Modes

Operating Mode	Button Press	Action
Normal Operation	Quick Press	Start manual override
Manual Override	Quick Press	Change manual override speeds
	Press and Hold 4 seconds	Exit manual override



Priming Mode

The XE pump has a built in self-priming feature which will cause the pump to operate at maximum speed for 8 minutes in order to self-prime after certain conditions.

The pump will prime when either of the following conditions are met:

- Power is first applied to the pump
OR
- An interval with a programmed speed follows an interval which was set to (STOP)
OR
- When completing programming or exiting override mode

Example:

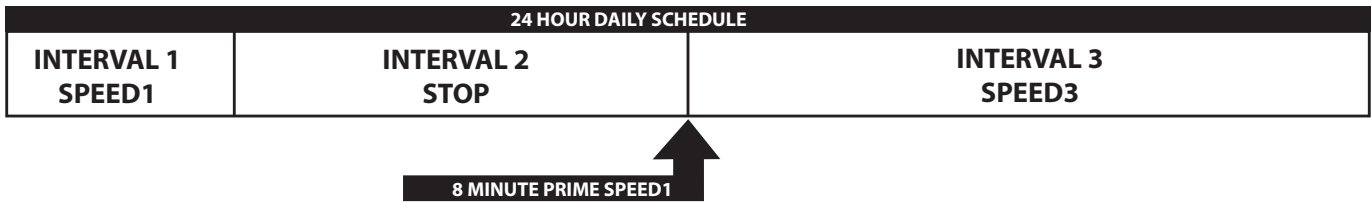

The pump will prime at the start of Interval 3 for 8 minutes, since Interval 2 was set to STOP.

If the desire is to prevent the pump from entering the 8 minute self-prime sequence, then this feature may be disabled by pressing and holding the button for 10 seconds during normal operation. To enable, press and hold again for 10 seconds.

Controlling the XE Pump with a Standard Timeclock

The XE line of pumps can be controlled by pump timers in the same manner as a typical single speed pump. The benefit of this configuration is that a timeclock with battery backup can ensure the start/stop time of the daily schedule in the event of power interruptions or routine maintenance. When using a pool pump timer, program your pump's three intervals to the desired settings. Set the timer to turn ON at the desired time of day. Set the timer to turn OFF 15 minutes earlier than the ON setting. Pump programming can be used to further customize the schedule similar to automation. Refer to your timeclock manufacturer's manual for wiring information.

Controlling the XE pump with a Pool Automation Control

The XE line of pumps can be controlled by automation controls using an ON/OFF output. This operation uses the automation control's high voltage relay to apply/remove power to the pump. If your pool automation control features a schedule function for the relay output, the pump can be turned on and off daily at preset times and be allowed to run for a fixed amount of time. Because there is no means of communication to the XE pumps, the automation control will not be able to offer remote programming or speed control, it will only turn the pump on and off to run the programmed daily schedule.

The most common application may be to run the pump at a single speed by setting all Interval speeds the same and have the pool control power it on and off each day. If various speeds are desired, combine Interval programming with the pool control's schedule to gain more control over the pump's operation. For example, you can control the exact amount of run time and end the operation in the middle of any Interval. Restarting the pump will always restart the daily schedule at Interval 1 so running two or more schedules in one day will allow you to repeat Interval(s) within a 24 hour period. This type of control is not available if the pump is connected to constant power.

When using a pool automation control, input wiring to the XE pump shown on page 8 will come directly from the relay output of the control. Refer to your specific pool control's manual for these wiring instructions.



Troubleshooting

Motor does not restart right away after power cycling and the LED is blinking

1. When removing power, ensure the LED turns off completely by waiting at least 30 seconds before reapplying power to the pump.

Motor Will NOT Start

1. Check wiring according to the diagrams on page 8. Verify input voltage to the pump.
2. Be sure the pump is wired for the available field supply voltage/current according to the pump data nameplate.
3. Check for and correct any improper or loose wiring connections; open switches or relays; tripped circuit breakers, or blown fuses.
4. Manually check the rotation of the motor shaft for free movement and lack of obstruction. Correct if necessary.

Motor shuts OFF and LED is not Solid ON

1. Check for low voltage or power drop at the motor (frequently caused by undersized wiring). Contact a qualified professional to verify the electrical connections.

Motor Hums, But Does NOT Start

1. Impeller jammed with debris. Have a qualified repair professional open the pump and remove the debris.

Pump Won't Prime

1. Empty pump/strainer housing. Make sure the pump/strainer housing is filled with water and the cover o-ring is clean. Ensure the o-ring is properly seated in the cover o-ring groove. Ensure the o-ring sealing surface is lubricated with "Jack's 327" and that the strainer cover is locked firmly in position. Lubricant will help to create a tighter seal.
2. Loose connections on the suction side. Tighten the pipe/union connections.
Note: Any self-priming pump will not prime if there are suction air leaks. Leaks will result in bubbles emanating from the return fittings on the pool wall.
3. Leaking O-ring or packing glands on valves. Tighten, repair, or replace the valves.
4. Strainer basket or skimmer basket loaded with debris. Remove the strainer housing cover or the skimmer cover. Clean the basket, and refill the strainer housing with water. Tighten the cover.
5. Suction side clogged. Contact a qualified repair professional. You should have 5" - 6" of vacuum at the strainer cover (your pool dealer can confirm this with a vacuum gauge). You may be able to check by removing the skimmer basket and holding an object over the bottom port with the skimmer full and the pump running. If no suction is felt, check for line blockage.
 - a. If the pump develops a vacuum, check for a blocked suction line or a dirty strainer basket. An air leak in the suction piping may be the cause.
 - b. If the pump does not develop a vacuum and the pump has sufficient "priming water":
 - i. Re-check the strainer housing cover and all threaded connections for suction leaks. Check if all system hose clamps are tight.
 - ii. Check voltage to ensure that the motor is rotating at full rpm's.
 - iii. Open the housing cover and check for clogging or obstruction in suction. Check the impeller for debris.
 - iv. Remove and replace the shaft seal only if it is leaking.

Low Flow – Generally

1. Clogged or restricted strainer or suction line. Contact a qualified repair professional.
2. Undersized pool piping. Correct the piping size.
3. Plugged or restricted discharge line of filter, valve partially closed (high gauge reading). Sand filters – backwash as per manufacturer's instructions; D.E. filters – backwash as per manufacturer's instructions; Cartridge filters – clean or replace the cartridge.
4. Air leak in suction (bubbles issuing from return fittings). Re-tighten the suction and discharge connections using PTFE tape. Inspect other plumbing connections, and tighten as required.
5. Plugged, restricted, or damaged impeller. Replace the impeller including a new seal assembly.

Noisy Pump

1. Air leak in suction piping, cavitations caused by restricted or undersized suction line or leak at any joint, low water level in pool, and unrestricted discharge return lines. Correct the suction condition or throttle return lines, if practical. Holding your hand over the return fitting will sometimes prove this, or by putting in a smaller eyeball fitting.
2. Vibration due to improper mounting, etc. Mount the pump on a level surface and secure the pump to the equipment pad.
3. Foreign matter in the pump housing. Loose stones/debris hitting the impeller could be the cause. Clean the pump housing.
4. Motor bearings noisy from normal wear, rust, overheating, or concentration of chemicals causing seal damage, which will allow chlorinated water to seep into bearings wiping out the grease causing bearing to whine. All seal leaks should be replaced at once.

System Errors

During normal operation (not programming mode), the XE pump can communicate errors through its LED Indicator. Errors are displayed by flashing the LED. The number of flashes will indicate the type of error as shown in the table below.

# of Flashes	Error Condition	Troubleshooting Steps
1	DC voltage out of range	Indicates that internal DC bus voltage is either too high or too low. Verify that line voltage is within 10% of pump rated voltage at the terminal block. Also, verify that power supply connections are properly made at the circuit breaker as well as at the terminal block, and that the voltage change jumper is set correctly for the intended line voltage connection.
2	Motor current too high	Indicates that motor current is too high. Check impeller, diffuser, shaft seal, and motor for any issues or binding.
3	IPM temperature too high	Indicates that the internal components of the motor drive have become overheated. Motor airflow path should be checked for obstructions and cleared if present. Also, check ambient temperature and verify against motor nameplate.
4	Pump has stalled	Indicates that the motor drive has lost control over motor shaft rotation, or that the motor drive was not able to start the motor. Check impeller, diffuser, shaft seal, and motor for any issues or binding.
5	Internal motor/drive failure	Indicates that there is a problem within the motor and/or motor drive assembly, and that the motor/drive assembly may need to be replaced. Contact Hayward Technical Service for additional assistance.

Note: All errors can be manually reset by pressing the button when the error is shown, or by cycling power applied to the pump after the error has occurred. If the troubleshooting steps listed above do not help to resolve the error condition, then the problem may be internal to the motor/drive. Contact Hayward Technical Service at (908) 355-7995 for additional assistance.

Maintenance

- Clean strainer basket regularly. Do NOT strike basket. Inspect cover gasket regularly and replace as necessary.
- Hayward pumps have self-lubricating motor bearings and shaft seals. No lubrication is necessary.
- Keep motor clean. Keep motor air vents free of obstructions to avoid damage. Do NOT use water to hose off motor.
- Occasionally, shaft seals must be replaced, due to wear or damage. Replace with genuine Hayward seal assembly kit. See “Shaft Seal Change Instructions” in this manual.

Storage / Winterization

 **WARNING** – Separation Hazard. Do not purge the system with compressed air. Purging the system with compressed air can cause components to explode, with risk of severe injury or death to anyone nearby. Use only a low pressure (below 5 PSI), high volume blower when air purging the pump, filter, or piping.

 **ATTENTION** – Allowing the pump to freeze with water in it will void the warranty.

 **ATTENTION** – Use ONLY propylene glycol as antifreeze in your pool/spa system. Propylene glycol is non-toxic and will not damage plastic system components; other anti-freezes are highly toxic and may damage plastic components in the system. Drain all water from pump and piping when expecting freezing temperatures or when storing pump for a long time (see instructions below). Gravity drain system as far as possible. Keep motor dry and covered during storage. To avoid condensation/corrosion problems, do NOT cover or wrap pump with plastic film or bags.

Storing Pump For Winterization

 **WARNING** – To avoid dangerous or fatal electrical shock hazard, turn OFF power to motor before draining pump. Failure to disconnect power may result in serious personal injury or death.

1. Drain water level below all inlets to the pool.
2. Remove drain plugs and strainer cover from strainer housing.
3. Disconnect pump from mounting pad, wiring (after power has been turned OFF), and piping.
4. Once the pump is fully drained of water, re-install the strainer cover and drain plugs. Store pump in a dry area.



HAYWARD®

Shaft Seal Change Instructions - TriStar XE

IMPORTANT SAFETY INSTRUCTIONS

PLEASE READ AND FOLLOW ALL INSTRUCTIONS

When servicing electrical equipment, basic safety precautions should always be observed including the following. Failure to follow instructions may result in injury

- **⚠ WARNING** – To reduce risk of injury, do not permit children to use this product.
- Disconnect all electrical power service to pump before beginning shaft seal replacement.
- Only qualified personnel should attempt rotary seal replacement. Contact your local authorized Hayward Dealer or service center if you have any questions.

Exercise extreme care in handling both the rotating and the stationary sections of the two-part replacement seal. Foreign matter or improper handling will easily scratch the graphite and ceramic sealing surfaces.

Removing the Motor Assembly

1. Remove the six (6) 5/16" x 2" hex head bolts, which hold the motor assembly to the pump/strainer housing, using a 1/2" wrench or socket.
2. Slide the motor assembly out of the pump/strainer housing, exposing the diffuser. Remove the two diffuser screws, and pull the diffuser off of the seal plate to expose the impeller.

Removing the Impeller

3. To prevent the motor shaft from turning, secure using a 5/16" hex wrench in the socket on the motor shaft.
4. Rotate the impeller screw clockwise (note that screw has left-hand thread) and remove. Remove the impeller by rotating counterclockwise.

Removing the Ceramic Seat

5. Remove the spring seal assembly and seal plate from the motor by removing the four (4) 3/8" x 1" bolts that secure it to the motor, using a 9/16" wrench or socket. Remove the motor support bracket from the seal plate.
6. Press the ceramic seat with rubber cup out of the seal plate. Use a small screwdriver to tap seal out.
STOP - Clean all recesses & parts to be reassembled. Inspect gaskets & replace if necessary.

Seal Installation

7. Clean and lightly lubricate the motor shaft and seal recesses in the seal plate with a dilute solution of non-granulated liquid-type soap. Gently wipe the polished face of the ceramic seal with a soft cotton cloth. Lubricate the rubber cup on the ceramic seat and press it firmly into the recess of the seal plate, with the polished ceramic surface facing out.
8. Reassemble the motor to the seal plate using the four (4) 3/8" x 1" bolts, and re-attach the motor support to the seal plate. Ensure that the upper two housing bolts are installed in the seal plate prior to mounting the motor to the seal plate.
9. Gently wipe the black, polished surface of the spring seal assembly with a soft cotton cloth.
10. Press the spring seal assembly onto the motor shaft, with the black polished surface facing the ceramic seat.

Replacing the Impeller and Diffuser

11. Screw the impeller onto the motor shaft in a clockwise direction, and screw the impeller screw into the motor shaft in a counterclockwise direction. Tighten snugly by holding motor shaft with wrench as noted in step #4. Place the impeller ring back onto the impeller, with flange facing towards the diffuser.
12. Place the diffuser over the impeller and onto the seal plate, aligning the three pins on the diffuser with the three holes on the seal plate. Replace the two diffuser screws.

Replacing the Motor Assembly

13. Slide the motor assembly, with the diffuser in place, into pump/strainer housing, being careful not to disturb the diffuser gasket.
14. Fasten assembly to pump/strainer housing using the six (6) 5/16" x 2" bolts. (Be sure housing gasket is in place, and lubricated. Replace if damaged). Tighten bolts alternately and evenly to 185 inch-pounds according to housing bolt torque pattern detail.



HAYWARD®

Shaft Seal Change Instructions - MaxFlo XE

IMPORTANT SAFETY INSTRUCTIONS

PLEASE READ AND FOLLOW ALL INSTRUCTIONS

When servicing electrical equipment, basic safety precautions should always be observed including the following. Failure to follow instructions may result in injury.

- **⚠ WARNING**— To reduce risk of injury, do not permit children to use this product.
- Disconnect all electrical power service to pump before beginning shaft seal replacement.
- Only qualified personnel should attempt rotary seal replacement. Contact your local authorized Hayward Dealer or service center if you have any questions.

Exercise extreme care in handling both the rotating and the stationary sections of the two-part replacement seal. Foreign matter or improper handling will easily scratch the graphite and ceramic sealing surfaces.

Removing the Motor Assembly

1. Remove the four (4) 5/16" x 1.75" hex head bolts, which hold the motor assembly to the pump/strainer housing, using a 1/2" wrench or socket.
2. Slide the motor assembly out of the pump/strainer housing, exposing the diffuser. Remove the three (3) diffuser screws and pull the diffuser off of the seal plate to expose the impeller.

Removing the Impeller

3. To prevent the motor shaft from turning, remove the wiring compartment cover, and secure the shaft using a 5/16" hex wrench.
4. Remove the impeller by rotating counterclockwise.

Removing the Ceramic Seat

5. Remove the spring seal assembly and seal plate from the motor by removing the four (4) 3/8" x 1" bolts that secure it to the motor, using a 9/16" wrench or socket.
 6. Press the ceramic seat with rubber cup out of the seal plate. If tight, use a small screwdriver to tap seal out.
- STOP - Clean all recesses & parts to be reassembled. Inspect gaskets & replace if necessary.

Seal Installation

7. Clean and lightly lubricate the motor shaft and seal recesses in the seal plate with a dilute solution of non-granulated liquid-type soap. Gently wipe the polished face of the ceramic seal with a soft cotton cloth. Lubricate the rubber cup on the ceramic seat and press it firmly into the recess of the seal plate, with the polished ceramic surface facing out.
8. Reassemble the motor to the seal plate using the four (4) 3/8" x 1" bolts. Torque the bolts to 100 in-lbs.
9. Gently wipe the black, polished surface of the spring seal assembly with a soft cotton cloth.
10. Press the spring seal assembly onto the motor shaft, with the black polished surface facing the ceramic seat.

Replacing the Impeller and Diffuser

11. Screw the impeller onto the motor shaft in a clockwise direction. Tighten snugly by holding motor shaft with wrench as noted in step #3. Replace the wiring compartment cover.
12. Place the diffuser over the impeller and onto the seal plate, aligning the three (3) pins with the matching holes in the seal plate. Note: Flat side of diffuser rim will face up. Replace the three (3) diffuser screws and torque to 20 in-lbs.

Replacing the Motor Assembly

13. Slide the motor assembly, with the diffuser in place, into pump/strainer housing, being careful not to disturb the diffuser gasket.
14. Fasten assembly to pump/strainer housing using the four (4) 5/16" x 1.75" bolts. (Be sure housing gasket is in place, and lubricated. Replace if damaged). Tighten bolts alternately and evenly to 185 inch-pounds. Looking at the back of the pump, start with the top right, move diagonal to the bottom left, then up to the top left and last across to the bottom right.



Shaft Seal Change Instructions - Super Pump XE

IMPORTANT SAFETY INSTRUCTIONS
PLEASE READ AND FOLLOW ALL INSTRUCTIONS

When servicing electrical equipment, basic safety precautions should always be observed including the following. Failure to follow instructions may result in injury.

- **⚠ WARNING** – To reduce risk of injury, do not permit children to use this product.
- Disconnect all electrical power service to pump before beginning shaft seal replacement.
- Only qualified personnel should attempt rotary seal replacement. Contact your local authorized Hayward Dealer or service center if you have any questions.

Exercise extreme care in handling both the rotating and the stationary sections of the two-part replacement seal. Foreign matter or improper handling will easily scratch the graphite and ceramic sealing surfaces.

Removing the Motor Assembly

1. Remove the four (4) 3/8" x 2" hex head bolts, which hold the motor assembly to the pump/strainer housing, using a 9/16" wrench or socket.
2. Slide the motor assembly out of the pump/strainer housing, exposing the diffuser. Pull the diffuser off of the seal plate to expose the impeller.

Removing the Impeller

3. To prevent the motor shaft from turning, remove the wiring compartment cover, and secure the shaft using a 5/16" hex wrench. Remove the impeller by rotating counterclockwise.

Removing the Ceramic Seat

4. Remove the spring seal assembly from the impeller and remove the seal plate from the motor.
5. Press the ceramic seat with rubber cup out of the seal plate. If tight, use a small screwdriver to tap seal out.

STOP - Clean all recesses & parts to be reassembled. Inspect gaskets & replace if necessary.

Seal Installation

6. Clean and lightly lubricate the motor shaft and seal recesses in the seal plate with a dilute solution of non-granulated liquid-type soap. Gently wipe the polished face of the ceramic seal with a soft cotton cloth. Lubricate the rubber cup on the ceramic seat and press it firmly into the recess of the seal plate, with the polished ceramic surface facing out.
7. Reassemble the motor to the seal plate.
8. Gently wipe the black polished surface of the spring seal assembly with a soft cotton cloth.
9. Press the spring seal assembly onto the impeller shaft, with the black polished surface facing the ceramic seat.

Replacing the Impeller and Diffuser

11. Screw the impeller onto the motor shaft in a clockwise direction. Tighten snugly by holding motor shaft with wrench as noted in step #3. Replace the wiring compartment cover
12. Place the diffuser over the impeller onto the seal plate

Replacing the Motor Assembly

14. Slide the motor assembly, with the diffuser in place, into pump/strainer housing, being careful not to disturb the diffuser gasket.
15. Fasten assembly to pump/strainer housing using the four (4) 3/8" x 2" bolts. (Be sure housing gasket is in place, and lubricated. Replace if damaged). Tighten bolts alternately and evenly to 80 inch-pounds. Looking at the back of the pump, start with the top right, move diagonal to the bottom left, then up to the top left and last across to the bottom right.



HAYWARD®

Replacement Parts

TriStar XE

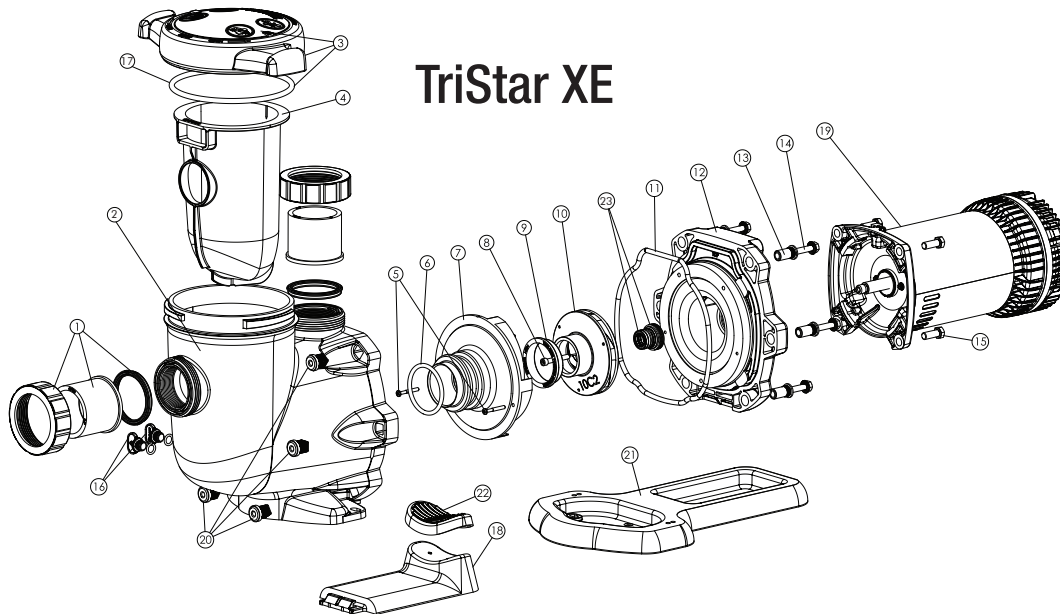

Ref. No.	Part No.	Description
1	SPX3200UNKIT	Union Connector Kit (Includes 2 Nuts, Connectors & Gaskets)
2	SPX3200A	Pump Strainer Housing, 2" x 2 1/2" with Drain Plugs
3	SPX3200DLS	Strainer Cover Kit (Includes Strainer Cover, Lock Ring & O-Ring)
4	SPX3200M	Strainer Basket
5	SPX3200Z8	Diffuser Screw
6	SPX4000Z1	Diffuser O-Ring
7	SPX3200B3	Diffuser
8	SPX3200Z1	Impeller Screw
9	SPX3021R	Impeller Ring
10A	SPX3207C	1.25THP Impeller with Impeller Screw
10B	SPX3210C	1.85THP Impeller with Impeller Screw
10C	SPX3215C	2.25THP Impeller with Impeller Screw
11	SPX3200T	Housing O-Ring
12	SPX3200E	Seal Plate
13	SPX3200Z211	Housing Insert/Seal Plate Spacer Kit
14	SPX3200Z3	Housing Bolt
15	SPX3200Z5PAK4	Motor Bolt (package of 4)
16	SPX4000FG	Drain Plug with O-Ring
17	SPX3200S	Strainer O-Ring
18	SPX3200GA	Motor Support
19A	SPX3207X10XEPE	1.25 HP Power End includes #5-#12, #15, #18, #19, #22, #23
19B	SPX3210X15XEPE	1.85 HP Power End includes #5-#12, #15, #18, #19, #22, #23
19C	SPX3215X20XEPE	2.25 HP Power End includes #5-#12, #15, #18, #19, #22, #23
20	SPX3200Z211	Housing Insert/Seal Plate Spacer Kit
21A	SPX3200WF	Optional Riser Base (aligns with Pentair® WhisperFlo® pump*)
21B	SPX3200SR	Optional Riser Base (aligns with Pentair® WhisperFlo® pump*)
22	SPX3200Q2	Motor Support Adapter
23A	SPX3200SA	Shaft Seal Assembly
23B	SPX4000SAV	Shaft Seal Assembly (Viton)

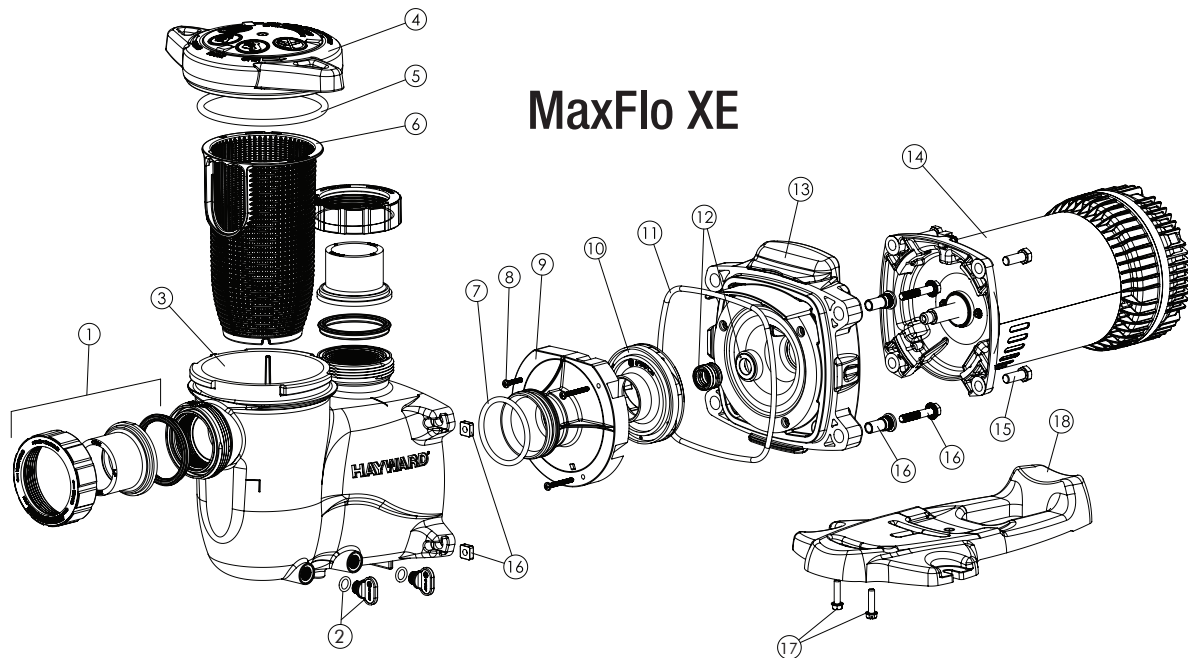

MaxFlo XE

Ref. No.	Part No.	Description
1	SPX2700UNKIT	Union Connector Kit (Includes 2 Nuts, Connectors & Gaskets)
2	SPX4000FG	Drain Plug with O-Ring
3	SPX2300AA	Pump Strainer Housing with Drain Plugs
4	SPX2300DLS	Strainer Cover Kit (Includes Strainer Cover, Lock-Ring & O-Ring)
5	SPX2300Z4	Strainer Cover O-Ring
6	SPX2300M	Strainer Basket
7	SX220Z2	Diffuser O-Ring
8	SPX2300Z3PAK3	Diffuser Screws (3 Pack)
9	SPX2300B	Diffuser
10A	SPX2710CM	1.65 THP Impeller
10B	SPX2715CM	2.25 THP Impeller
11	GMX600F	Housing O-Ring
12A	SPX2700SA	Shaft Seal Assembly
12B	SPX2700SAV	Shaft Seal Assembly (Viton)
13	SPX2300E	Seal Plate
14A	SPX2310X15XEPE	1.65 HP Power End includes #7-#15
14B	SPX2315X20XEPE	2.25 HP Power End includes #7-#15
15	SPX3200Z5PAK4	Motor Bolt (package of 4)
16	SPX2700ZPAK	Hardware Pack (Includes 4 Housing Bolts, Seal-Plate Spacers & Square Nuts)
17	SPX1600Z52	Motor Support Base Mount Screws
18	SPX2300G	Motor Support (VSP) with Base Mount Screws



HAYWARD®

Super Pump XE

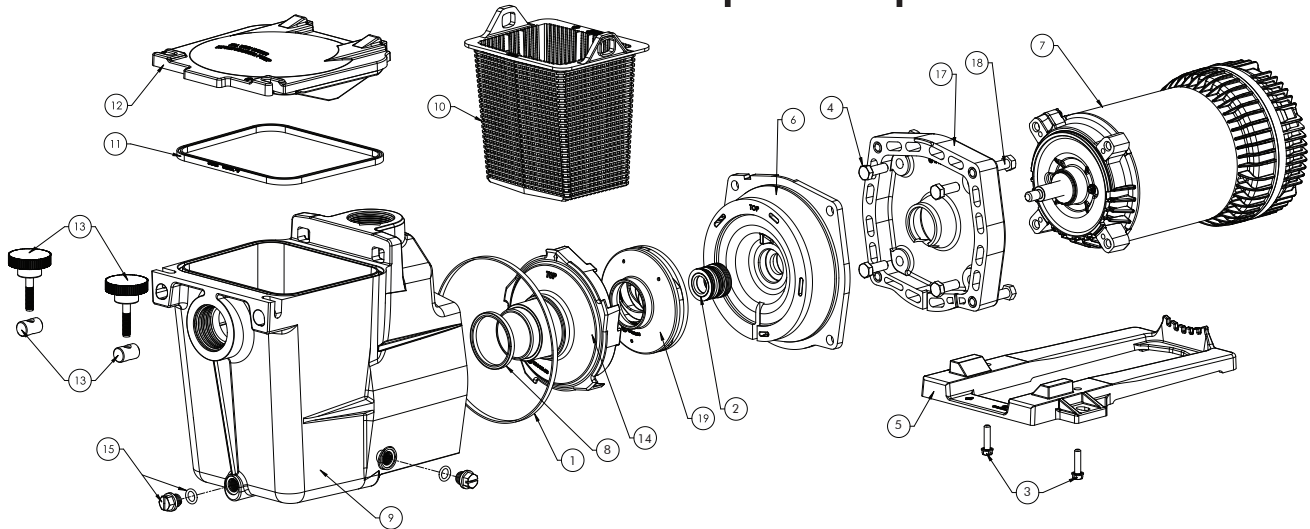

Ref. No.	Part No.	Description
1	SPX1600T	Housing Gasket
2A	SPX1600Z2	Shaft Seal Assembly
2B	SPX1600Z2VIT	Shaft Seal Assembly (Viton)
3	SPX1600Z52	Mounting Foot Screws (Set of 2)
4	SPX3200Z5PAK4	Motor Cap Screws (Set of 4)
5	SPX2600G1	Mounting Foot, VSP (Includes Screws)
6	SPX2600E5	Seal Plate
7A	SPX2610X15XEPE	1.65 HP Power End includes #2, #4, #6-#8, #14, #17, #19
7B	SPX2615X20XEPE	2.25 HP Power End includes #2, #4, #6-#8, #14, #17, #19
8	SPX1600R	Diffuser Gasket
9	SPX1620AA	Pump Strainer Housing With Gasket
10	SPX1600M	Basket
11	SPX1600S	Strainer Cover Gasket
12	SPX1600D	Strainer Cover
13	SPX1600PN	Swivel Nut & Hand Knob
14	SPX2600B	Diffuser
15	SPX1700FG	Drain Plug with Gasket
17	SPX1600F5	Motor Mounting Plate
18	SPX1600Z4	Housing Cap Screw
19A	SPX2610C	1.65 THP Impeller
19B	SPX2615C	2.25 THP Impeller



Supplier's Declaration of Conformity

47 CFR § 2.1077 Compliance Information

Unique Identifier: TriStar XE, MaxFlo XE, Super Pump XE
FCC Responsible Party:
Hayward Pool Product
400 Connell Drive, Suite 6100
Berkeley Heights, NJ 07922
hayward.com

This device complies with part 15 of the FCC Rules. Operation is subject to the following two conditions: (1) This device may not cause harmful interference, and (2) this device must accept any interference received, including interference that may cause undesired operation.

Changes or modifications not expressly approved by Hayward could void the user's authority to operate this equipment.

NOTE: This equipment has been tested and found to comply with the limits for a Class B digital device, pursuant to Part 15 of the FCC Rules. These limits are designed to provide reasonable protection against harmful interference in a residential installation. This equipment generates, uses and can radiate radio frequency energy and, if not installed and used in accordance with the instructions, may cause harmful interference to radio communications. However, there is no guarantee that interference will not occur in a particular installation. If this equipment does cause harmful interference to radio or television reception, which can be determined by turning the equipment off and on, the user is encouraged to try to correct the interference by one or more of the following measures:

- Reorient or relocate the receiving antenna.
- Increase the separation between the equipment and receiver.
- Connect the equipment into an outlet on a circuit different from that to which the receiver is connected.
- Consult the dealer or an experienced radio / TV technician for help.

This Class B digital apparatus complies with Canadian ICES-003.

Cet appareil numérique de la classe B est conforme à la norme NMB-003 du Canada.

For further information or consumer
technical support, visit our website at
www.hayward.com
US: 908-355-7995



Tristar XE, MaxFlo XE and Super Pump XE are registered trademarks
of Hayward Industries, Inc. © 2023 Hayward Industries, Inc.

All other trademarks not owned by Hayward are the property of their respective owners. Hayward is not in any way
affiliated with or endorsed by those third parties. For patent information, refer to www.hayward.com/patents.

