

ST5540

HIOKI

ST5541

Instruction Manual

LEAK CURRENT HiTESTER

EN

Contents

Measurement Flowchart..... 1
 Introduction.....2
 Inspection.....2
 Checking the contents of the package2
 Safety Notes.....3
 Usage Notes.....5

Chapter 1 Overview 7

1.1 Instrument Overview7
 1.2 Features8
 1.3 What is Leakage Current? 10
 1.4 Leakage Current Measurement
 Complying with Standards 11
 1.5 Types of Leakage Current 12
 1.6 Types of Leakage Current
 Measurement 13

Chapter 2 Instrument Labels and Screens 23

2.1 Instrument Labels and Functions
 24
 2.2 Screen configuration outline27
 2.3 About the Touch Panel 30

Chapter 3 Setting Preparations 31

3.1 Power switch, breaker ON/OFF 31
 3.2 Connecting the Power Cord 3..... 2
 ■Connecting the instrument power cord32
 ■Connecting the power cord of the
 equipment under test33
 ■Making connections to terminals S10, S12
 and S1335
 3.3 Connecting equipment under

 ■Connect the terminal 36
 3.4 Turning Power On and OFF38
 ■Turning Power On 38
 ■Turning Power Off 40
 3.5 Pre-Test Inspection 41
 ■Checking measurement frequency 43
 ■Connection/VA check screen 44

Chapter 4 Settings 47

4.1 Selecting a Network48
 4.2 Selecting the Grounding Class of
 Equipment Under Test49
 ■Registering an Equipment Name/
 Control Number..... 50
 4.3 Selecting a Measurement Mode
 (opens the measurement screen)
51
 4.4 Setting the Measurement Range
 (Auto/Hold)54
 4.5 Setting the Filter59
 4.6 Setting the Allowable Value61
 ■Turning lower limit values on and off for
 specific leakage current measurements .. 63
 4.7 Selecting the Type of Target
 Current 64
 4.8 Changing the Measurement
 Method (Auto/Manual)67
 ■Setting automatic measurement items 68
 ■Setting the measurement delay
 (delay time) 70
 ■Setting the measuring time 73

Chapter 5 Measurement Preparations 75

5.1 Connecting the Test Lead 75
 ■Using L2200 Test Lead 77
 ■Using the 9195 Enclosure Probe

- Using Alligator Clips (when using two or three test leads)78

Chapter 6 Measurements 79

- 6.1 Making manual measurements 79
- 6.2 Making automatic measurements 82
- 6.3 Measurement examples 83
 - Earth leakage current measurement 83
 - Touch current measurement 84
 - Patient leakage current measurement* (Patient connection - Earth) 90
 - Patient leakage current measurement* (external voltage on a SIP/SOP)..... 93
 - Patient leakage current measurement* (external voltage on a specific F-type applied part) 95
 - Patient leakage current measurement* (external voltage on metal accessible part not protectively earthed) 97
 - Patient auxiliary current measurement* 99
 - Total patient leakage current measurement* (Patient connection - Earth) 100
 - Free current measurement (Enclosure - Enclosure) 101
- 6.4 Saving Measurement Data (As required) 102
 - Checking Saved Measurement Data 104
 - Displaying Saved Measurement Data 104
 - Selecting Saved Measurement Data 105
 - Deleting Saved Data 105
- 6.5 Saving Measurement Conditions (Panel Save Function) (as required) 106
- 6.6 Printing Measurement Data (as required) 108
 - Setting up and connecting a printer 108

Chapter 7 Instrument System Settings 115

- System Screen Configuration 116
- 7.1 Setting the Mode (To use the instrument as a voltmeter) 117

- 7.2 Panel Load(Loading Saved Measurement Conditions)..... 120
- 7.3 Initializing the Instrument 121
- 7.4 Setting the Display Language 123
- 7.5 Checking Fuses(During Earth leakage current and protective conductor current measurements) 123
- 7.6 Self-Test 124
- 7.7 Power On Polarity Switching (to keep equipment under test on during polarity switching) .. 126
 - Connect the isolation transformer..... 126
 - Setting Power On Polarity Switching 127
 - Relay check 2 128
- 7.8 Auto Measure Setting (set instrument status) 129
- 7.9 Setting Lower Limit Values (factor) 130
- 7.10 Setting Indication Unit 131
- 7.11 Setting Date and Time 132
- 7.12 Interface Setting (For Communication and Printing) 133
- 7.13 Setting the Beep Sound 135
- 7.14 Setting the Backlight 136

Chapter 8 Controlling the Instrument From a Computer (RS-232C, USB interface) 139

- 8.1 ST5540/ST5541 Remote Interface Overview (USB connection) ... 140
- 8.2 Connect and be sure to tighten the screws on the connector.. 141
 - Installation and operation procedures 143
 - Specifications of RS-232C..... 144
 - Specifications of USB 144

8.3	Setting Communication Conditions on the HiTESTER	145
8.4	Command Message Description	146
	■ Message Format	146
	■ Output Queue and Input Buffer	151
	■ Event Registers	152
8.5	Initialization Items	153
8.6	Message Reference	154
	■ Common Messages	154
	■ Messages Specific to the HiTESTER.....	154
8.7	Command Message Description	162
	■ Common Messages	163
	■ Specific commands	165
8.8	To Transfer All Saved Data to a Computer	243
8.9	Troubleshooting	244

Chapter 9 External Control 245

9.1	Description of Signals	246
9.2	Connecting to the EXT I/O Terminal	247
9.3	Electrical Specifications	249
9.4	Internal Circuit Configuration ..	250
9.5	Timing Chart	251
	■ Panel load function at EXT I/O start	253
9.6	Example of Output Signal Connection	254

Chapter 10 Specifications 255

10.1	Basic Functions.....	255
10.2	Auxiliary measurement functions*	256
10.3	Measurement System	256
10.4	Accuracy	258

■ Network Section	259	
10.5	Other Functions	261
10.6	System-related Functions	263
10.7	User interface	264
10.8	EXT I/O	264
10.9	Relay output for medical equipment (only ST5540)	264
10.10	PC Interfaces	265
10.11	Printer	265
10.12	General Specifications	266
10.13	Compliant standards	268
10.14	Measurement Networks	269
	■ Network A (for Electrical Appliance and Material Safety Law)	269
	■ Network B1 (for JIS T 0601-1:1999)	270
	■ Network B2 (for IEC 60601-1:2005 3rd) ..	271
	■ Network C (for IEC 60990)	272
	■ Network D (for UL)	274
	■ Network E (General-purpose 1)	275
	■ Network F (General-purpose 2)	275
	■ Network G (for IEC61010-1)	276

Chapter 11 Maintenance and Service 279

11.1	Cleaning and Storage	279
11.2	Repair and Servicing	280
11.3	Replacing Fuses	282
11.4	Instrument Disposal	283

Appendix A1

Appendix1	Terminology	A1
Appendix2	List of instrument status, other test condition and special test condition	A4
Appendix3	List of default settings	A7
Appendix4	External Dimensions	A29

Measurement Flowchart

Be sure to read "Usage Notes" (p. 5) before measuring.

The flowchart does not show the detailed procedures but the rough workflow.

Connect the power cord

See "Connecting the instrument power cord" (p. 32)

See "Connecting the power cord of the equipment under test"

(p. 33)

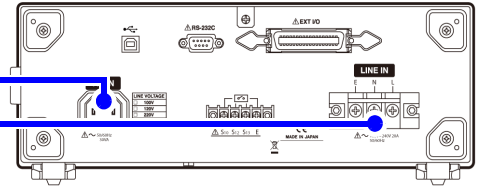

Connecting equipment under test to the instrument

See "3.3 Connecting equipment under test to the instrument" (p. 36)

The actual connection procedure will vary with the power supply of the equipment under test.

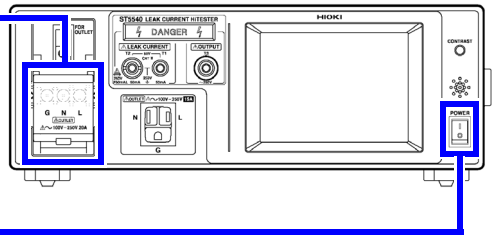

Turn on the power switch of the HiTESTER

See "3.4 Turning Power On and OFF" (p. 38)

Pre-Operation Inspection

See "3.5 Pre-Test Inspection" (p. 41)

Settings

See "Chapter 4 Settings" (p. 47)

Settings depend on measurement method (Manual or Automatic)

Manual measurement : Perform settings from (p. 48) to (p. 67)

Automatic measurement : Perform settings from (p. 48) to (p. 73)

Turn on the circuit breaker

See "3.1 Power switch, breaker ON/OFF" (p. 31)

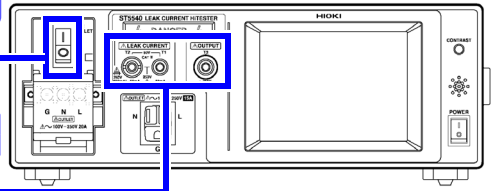

Connect test leads

See "5.1 Connecting the Test Lead" (p. 75)

Measurements

See "Chapter 6 Measurements" (p. 79)

Manual : Free-run measurement

(Measurement conditions can be changed during ongoing measurements)

Automatic : Set measurement conditions and measuring time to perform automatic measurements.

After automatic measurement ends

See "6.4 Saving Measurement Data (As required)" (p. 102)

See "6.5 Saving Measurement Conditions (Panel Save Function) (as required)" (p. 106)

See "6.6 Printing Measurement Data (as required)" (p. 108)

Turn off breakers and instrument power

See "3.1 Power switch, breaker ON/OFF" (p. 31)

See "3.4 Turning Power On and OFF" (p. 38)

Disconnect test leads and equipment under test

Introduction

Thank you for purchasing the HIOKI Model "ST5540/ST5541 Leak Current HiTester". To obtain maximum performance from the instrument, please read this manual first, and keep it handy for future reference.

Inspection





When you receive the instrument, inspect it carefully to ensure that no damage occurred during shipping. In particular, check the accessories and connectors. If damage is evident, or if it fails to operate according to the specifications, contact your dealer or Hioki representative.

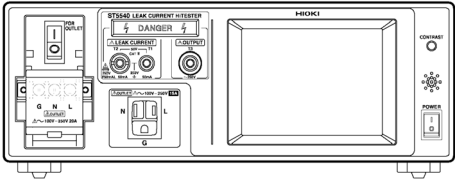
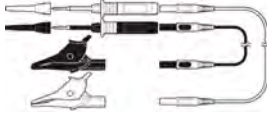
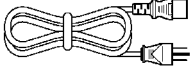

- Before using the instrument, make sure that the insulation on the test leads is undamaged and that no bare conductors are improperly exposed. Using the Model L2200 Test Lead in such conditions could cause an electric shock, so contact your dealer or Hioki representative for replacements.
- Before using the instrument, make sure that the insulation on the power cords is undamaged and that no bare conductors are improperly exposed. Using the instrument in such conditions could cause an electric shock, so contact your dealer or Hioki representative for replacements.
- Use the original packing materials when transporting the instrument, if possible.

Checking the contents of the package

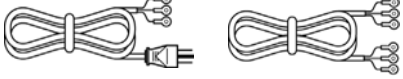
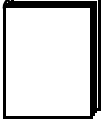
Confirm that these contents are provided.

- | | |
|--|--|
| <input type="checkbox"/> "ST5540/ST5541 Leak Current HiTester"..... 1 | <input type="checkbox"/> Spare fuse for main instrument 1
(250 V F50 mA) |
|  | <input type="checkbox"/> L2200 Test Lead.....1set
(1 red, 1 black) |
| <input type="checkbox"/> Power cord (for main instrument)..... 1 |  |
|  | <input type="checkbox"/> Test lead(red) 1
(only ST5540) |
| <input type="checkbox"/> Power cord for equipment under test..... 2
(for [LINE IN]) |  |
|  | <input type="checkbox"/> Instruction manual..... 1 |
| <input type="checkbox"/> Enclosure Probe..... 1 |  |
|  | <input type="checkbox"/> CD-ROM 1 |
| |  |

Safety Notes



This instrument is designed to comply with IEC 61010 Safety Standards, and has been thoroughly tested for safety prior to shipment. However, mis-handling during use could result in injury or death, as well as damage to the instrument. Using the instrument in a way not described in this manual may negate the provided safety features.

Be certain that you understand the instructions and precautions in the manual before use. We disclaim any responsibility for accidents or injuries not resulting directly from instrument defects.

This manual contains information and warnings essential for safe operation of the instrument and for maintaining it in safe operating condition. Before using it, be sure to carefully read the following safety precautions.



Safety Symbols

	In the manual, the symbol indicates particularly important information that the user should read before using the instrument.
	The symbol printed on the instrument indicates that the user should refer to a corresponding topic in the manual (marked with the symbol) before using the relevant function.
	Indicates a fuse.
	Indicates a grounding terminal.
	Indicates AC (Alternating Current).
	Indicates the ON side of the power switch.
	Indicates the OFF side of the power switch.
	Indicates that the product conforms to regulations set out by the EC Directive.
	WEEE marking: This symbol indicates that the electrical and electronic appliance is put on the EU market after August 13, 2005, and producers of the Member States are required to display it on the appliance under Article 11.2 of Directive 2002/96/EC (WEEE).

The following symbols in this manual indicate the relative importance of cautions and warnings.

	Indicates that incorrect operation presents an extreme hazard that could result in serious injury or death to the user.
	Indicates that incorrect operation presents a significant hazard that could result in serious injury or death to the user.
	Indicates that incorrect operation presents a possibility of injury to the user or damage to the instrument.
	Indicates advisory items related to performance or correct operation of the instrument.

Other Symbols

	Indicates a prohibited action.
See	Indicates the location of reference information.
*	Indicates that descriptive information is provided below.
<i>(Example)</i> <i>Leakage current</i>	For information on text in italics, refer to "Appendix1 Terminology" (p. A1).
	Indicates descriptions relating to the RS-232C only.
	Indicates descriptions relating to the USB only.

Accuracy

We define measurement tolerances in terms of f.s. (full scale), rdg. (reading) and dgt. (digit) values, with the following meanings:

f.s. (maximum display value):	The maximum displayable value. This is usually the name of the currently selected range.
rdg. (reading or displayed value):	The value currently being measured and indicated on the measuring instrument.
dgt. (resolution):	The smallest displayable unit on a digital measuring instrument, i.e., the input value that causes the digital display to show a "1" as the least-significant digit.

Measurement categories

This instrument complies with CAT II (300 V) safety requirements.

To ensure safe operation of measurement instruments, IEC 61010 establishes safety standards for various electrical environments, categorized as CAT II to CAT IV, and called measurement categories.

CAT II :	Primary electrical circuits in equipment connected to an AC electrical outlet by a power cord (portable tools, household appliances, etc.) CAT II covers directly measuring electrical outlet receptacles.
CAT III :	Primary electrical circuits of heavy equipment (fixed installations) connected directly to the distribution panel, and feeders from the distribution panel to outlets.
CAT IV :	The circuit from the service drop to the service entrance, and to the power meter and primary overcurrent protection device (distribution panel).

Using a measurement instrument in an environment designated with a higher-numbered category than that for which the instrument is rated could result in a severe accident, and must be carefully avoided.

Use of a measurement instrument that is not CAT-rated in CAT II to CAT IV measurement applications could result in a severe accident, and must be carefully avoided.

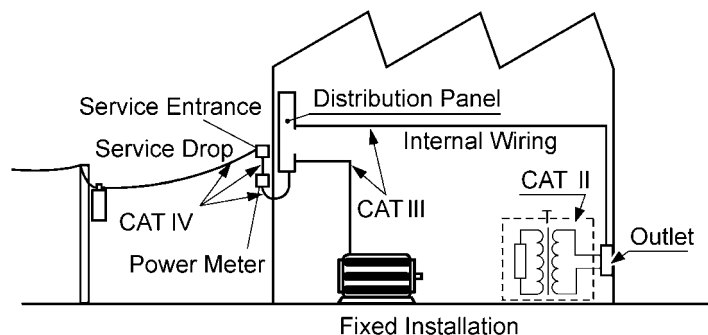







Usage Notes



Follow these precautions to ensure safe operation and to obtain the full benefits of the various functions.

Avoid the following locations that could cause an accident or damage to the instrument.

	Exposed to direct sunlight Exposed to high temperature		In the presence of corrosive or explosive gases
	Exposed to water, oil, other chemicals, or solvents Exposed to high humidity or condensation		Exposed to strong electromagnetic fields Near electromagnetic radiators
	Exposed to high levels of particulate dust		Near induction heating systems (e.g., high-frequency induction heating systems and IH cooking utensils)
	Subject to vibration		

WARNING

Avoid obstructing the ventilation holes on the sides of the instrument, as it could overheat and be damaged, or cause a fire.

NOTE

If the instrument operates abnormally or displays an abnormal indication, turn off the power switch immediately, and contact your dealer or Hioki representative.

Precautions before measurement

WARNING

- Before turning on the instrument, confirm that the voltage of the power source matches the voltage specification indicated on the instrument's power connector ([AC IN]). (The voltage specification (100, 120, 220 or 240 V) ordered by the customer is marked with a black dot ● in the line voltage column on the rear panel.)

Note that using the power supply with improper voltage may damage the instrument and result in electrical hazards.

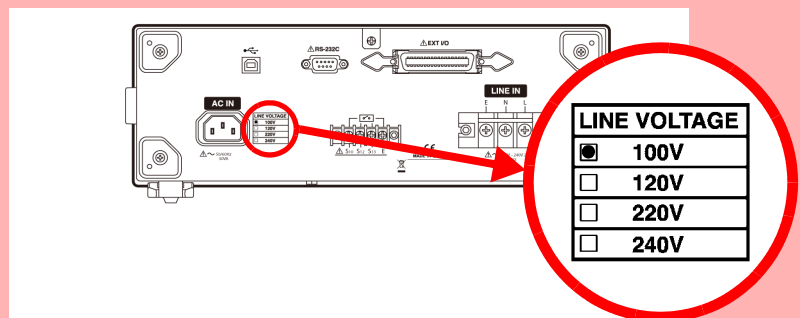

- To avoid electrical accidents and to maintain the safety specifications of this instrument, connect the power cord provided only to a 3-contact (two-conductor + ground) outlet.

CAUTION

Do not use excessive force on the touch panel, and do not use sharp objects that could damage the touch screen.

Fuse

! WARNING

- Replace the fuse only with one of the specified characteristics and voltage and current ratings. Using a non-specified fuse or shorting the fuse holder may cause a life-threatening hazard.
Measurement terminal section : 250 V F50 mA
- To avoid electric shock, turn off the power switch and disconnect the power cord and test leads before replacing the fuse.
- Since a blown fuse cannot be repaired or replaced by the customer, contact your dealer or nearest Hioki sales office.
Use the VA check function for power supply fuse and blown fuse check function for measurement circuit fuse to check for blown fuses.

Connection

! CAUTION

- Always turn both devices OFF when connecting and disconnecting an interface connector and test lead. Otherwise, an electric shock accident may occur.
- To avoid damaging the power cord, grasp the plug, not the cord, when unplugging it from the power outlet.
- To avoid breaking the test lead or enclosure probe, do not bend or pull them.
- When the power is turned off, do not apply voltage or current to the measurement terminals. Doing so may damage the instrument.
- L (Line), N (Neutral) and G (Ground) are indicated on the terminal block of the instrument, and the contacts of the power cord of the device to be measured are denoted L, N and E (Earth). If the power cord does not include an earth (E) line, connect only the L and N terminals.
For details regarding the terminal block, refer to "3.3 Connecting equipment under test to the instrument" (p. 36).

Measurement

! WARNING

To avoid the risk of electric shock when test leads are connected to the T1 - T3 terminals, do not touch the part of the test lead that is beyond the finger barrier.
The terminals output high voltages in some measurement modes.

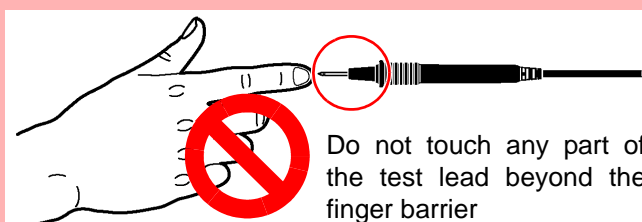

Do not touch any part of the test lead beyond the finger barrier

Overview

Chapter 1

1.1 Instrument Overview

To ensure the safe use of electrical products, it is necessary to conduct electrical safety tests such as insulation resistance, withstand voltage, ground resistance, and leakage current.

Complying with laws and standards regarding medical electrical equipment as well as non-medical electrical equipment, this instrument can be used to measure leakage current in all types of electrical products from computers to medical equipment. It consists of measurement networks that simulate the human body and a high-frequency volt meter.

It is also capable of switching power supply polarities and making measurements under simulated single-fault conditions in equipment under test.

To simplify leakage current testing, all test operations can be selected and run from a touch panel on the display screen.

Applicable lines of business and product applications

Manufacturers of medical electrical equipment	Type approval testing, shipment inspection
Dealers of medical electrical equipment	Maintenance, inspection
Service technicians for medical electrical equipment (authorized service technicians)	Maintenance, inspection
Clinical engineers, hospitals	Maintenance, inspection
Clinical engineering schools	For educational purposes
Authorized electricians for operating rooms, ICUs, and CCUs	Isolation transformer inspection
Public organizations	Type inspection
Manufacturers of general electrical equipment	Type inspection, shipment inspection
Users of general electrical equipment	Maintenance, inspection
General electrical equipment installers	Maintenance, inspection
Service technicians for general electrical equipment	Maintenance, inspection
Manufacturers of general electrical equipment parts	Type inspection, shipment inspection
Manufacturers of power supply equipment	Type inspection, shipment inspection
Manufacturers of electrical automobiles	Type inspection, shipment inspection

1.2 Features

◆ Wide range of measurement networks in compliance with standards and laws

To test electrical equipment for leakage current, it is necessary to use a measurement network that simulates the human body in compliance with applicable standards or laws.

The instrument includes the 8 measurement networks below.

- | | | | |
|---------------|---|--------------|------------------------|
| 1. Network A | :For compliance with Electrical Appliance and Material Safety Law | 5. Network D | :For UL |
| 2. Network B1 | :For JIS T0601-1:1999 | 6. Network E | :For general-purpose 1 |
| 3. Network B2 | :IEC 60601-1:2005 3rd
Complies with JIS T 0601-1:2012 | 7. Network F | :For general-purpose 2 |
| 4. Network C | :For IEC60990 | 8. Network G | :For IEC 61010-1 |

The use of these networks enables instrument compliance with other standards.

◆ Leakage current measurement mode

Once a measurement network is selected, the instrument displays a leakage current measurement mode corresponding to the applicable standard or law.

1. Earth leakage current
2. Touch current (Enclosure - Earth)
3. Touch current (Enclosure - Enclosure)
4. Touch current (Enclosure - Line)
5. Patient auxiliary current
6. Patient leakage current (Patient connection - Earth)
7. Patient leakage current (external voltage on a SIP/SOP^{*})
8. Patient leakage current (external voltage on a specific F-type applied part)
9. Patient leakage current
(external voltage on metal accessible part not protectively earthed)
10. Total patient leakage current (Patient connection - Earth)
11. Total patient leakage current (external voltage on a SIP/SOP^{*})
12. Total patient leakage current (external voltage on a specific F-type applied part)
13. Total patient leakage current
(external voltage on metal accessible part not protectively earthed)
14. Free current (Enclosure - Enclosure)
15. Enclosure - Earth leakage current
16. Enclosure - Enclosure leakage current
17. Enclosure - Line leakage current
18. Patient leakage current I
19. Patient leakage current II
20. Patient leakage current III

*SIP(Signal Input Part)/SOP(Signal Output Part)

◆ Power on polarity switching function

This function makes it possible to continue testing without shutting down the equipment under test when polarities are changed, which shortens the duration of the test.

(Be sure to use an isolation transformer when using power on polarity switching.)

◆ Rated current 20 A

The instrument provides a rated current of 20 A and a rated voltage of 250 V.

◆ **Function for checking for blown fuses**

The instrument allows you to check for unintended blown fuses in networks. Check for blown fuses before and after measurements to enable high-reliability measurements.

◆ **Ease of operation**

All operations are performed using the touch panel. The display shows operable keys and the interactive system guides you through measurement procedures.

◆ **Interfaces**

The RS-232C, EXT I/O and USB interfaces are provided as standard equipment to enable the easy transfer of measurement data with a computer. The EXT I/O connector allows external control.

◆ **Printing (with optional printer)**

Connect the optional 9442 Printer to print out measurement data and saved measurement data.

◆ **Monitor function**

The instrument is equipped with a function to monitor the power supply voltage and current of equipment under test.

1.3 What is Leakage Current?

High voltage is present in an electrical appliance that uses a commercial power supply as its main power source. Touching such equipment may expose a person to an electrical shock when current passes through the body to ground. This electrical shock is the result of "leakage current" or "touch current." Normally, electrical equipment is grounded to protect against electrical shocks. Current regularly flows through the grounding wire, but should an abnormality (due to faulty design or fault) occur in equipment, the resulting electrical shock may cause serious personal injury and sometimes lead to the death of the victim. For this reason, leakage current measurements including *single-fault conditions*^{*1} are strictly regulated.

Leakage current measurements performed according to the applicable standard makes it possible to verify the safety of equipment.

^{*1}What is a *single-fault condition*?

This refers to when equipment has a fault in a safety protection measure, or a fault that may result in a hazardous condition.

Leakage current testing includes the following three *single-fault conditions*.

1. Disconnected grounding wire (not applicable in current tests of leakage current)
2. One wire in the power cord is disconnected (neutral power supply wire)
3. External equipment damage^{*2}
(patient leakage current II and patient leakage current III)

^{*2} In JIS T0601-1:1999 classified as a single-fault condition.

Not a *single-fault condition*, the instrument is capable of switching polarity during measurements and retaining a recording of the phase with the highest leakage current.

1.4 Leakage Current Measurement Complying with Standards

Electrical safety standards and laws are enacted for electrical products according to fields of application. Each standard and law specifies a circuit network for simulating the human body, and prescribes network performance, as well as measuring locations, type (e.g., AC, DC) of current to be measured, allowable values, and other characteristics.

Listed below are various standards that require leakage current measurement.

Standards requiring leakage current measurement

(Refer to the User's Guide for information on other standards.)

Electrical equipment	
IEC 60065:2001 +A1:2005	Audio, video, and similar electronic apparatus - Safety requirements
IEC60335-1:2010	Safety of household and similar electrical appliances. - Part 1: General requirements
IEC 60950-1:2005	Safety of information technology equipment
IEC 60990:1999	Methods of measuring touch current and protective conductor current
UL2231-1, UL2231-2	Personnel Protection Systems for EV
Electric measuring instruments	
IEC 61010-1:2010	Safety requirements for electrical equipment used in measurements, control and laboratories Current measurement circuits for testing in damp conditions
Medical electrical equipment	
JIS T 0601-1:1999 JIS T 0601-1:2012	Medical electrical equipment-Part1:General requirements for basic safety and essential performance
IEC 60601-1:2005 3rd	Medical electrical equipment Part 1: General requirements for safety

1.5 Types of Leakage Current

Leakage current can largely be classified as shown in the table below.

Types of Leakage Current	Overview	Reference Page
Earth leakage current	This refers to electric current that flows through a <i>protective earth conductor</i> to the ground.	P.13
Touch current Enclosure leakage current	Touch current is electric current that flows through a person who touches an ungrounded enclosed section of equipment. It does not include current that flows to the human body in contact with an <i>applied part</i> .	P.14
Patient leakage current	Patient leakage current flows through the body of someone connected to the <i>applied part</i> . Test items vary based on the type of <i>applied part</i> .	P.15
Patient auxiliary current	Electric current that flows between <i>applied parts</i> and through a patient during normal operation of medical equipment that is not intended to have any physiological effect.	P.15
Total patient leakage current	When multiple <i>applied parts</i> are attached to a patient, the total leakage current must be measured. The sum of patient leakage current of <i>applied parts</i> is total patient leakage current.	P.19
Protective conductor current	Electric current that flows through a protective earth conductor (grounding wire) during normal operating conditions	P.20

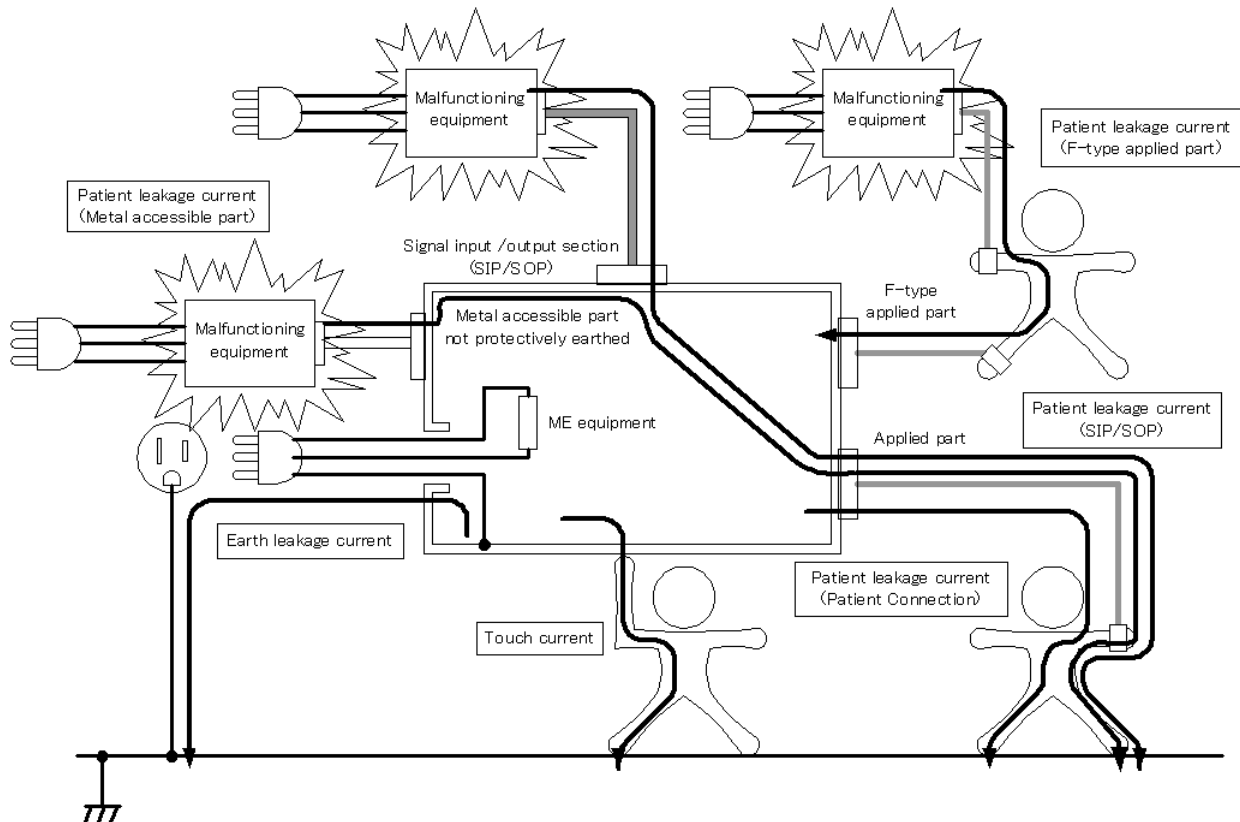

1.6 Types of Leakage Current Measurement

Earth leakage current measurement

Class-II equipment does not require the measurement of Earth leakage current since it has no protective earth conductor.

Earth leakage current is measured by inserting a resistance equivalent to the human body in the *protective earth conductor*. Using a clamp (Clamp On HiTester) for measuring current does not satisfy the standard.

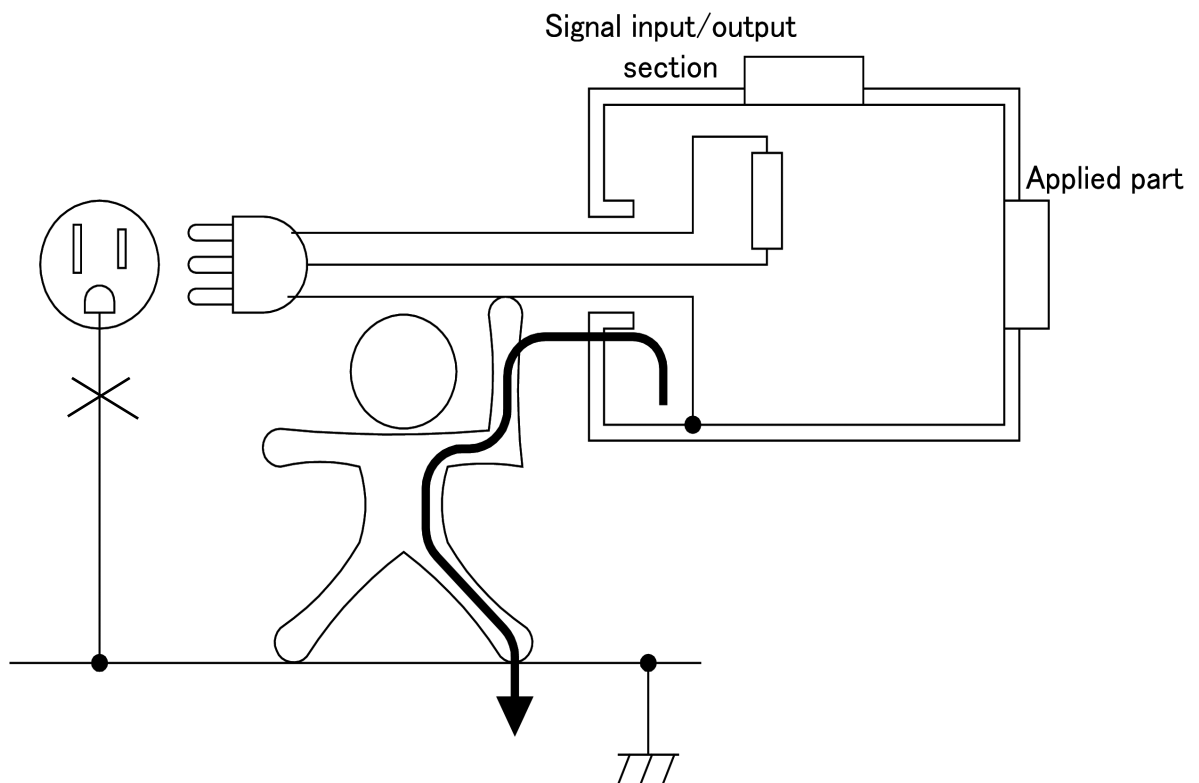

1.6 Types of Leakage Current Measurement

Touch current measurement

Class-I equipment does not require the measurement of enclosure leakage current since metal enclosures must be grounded for electrical protection. However, when the *protective earth conductor* becomes disconnected (single fault), the enclosure is no longer grounded for protection and must be measured.

For *Class-II* equipment, all enclosures are ungrounded for electrical protection and must be tested.

Ungrounded equipment are often made of plastics and other insulated materials. Since leakage current flows through the human body, the standard stipulates that a probe is applied to metal foil the size of a hand pressed against the insulated material. Use the 9195 enclosure probe supplied with the instrument for measurements involving this instrument.

There are two paths for touch current to flow: "enclosure → human body → earth" and "enclosure → human body → enclosure." Note that for "enclosure → human body → enclosure" to occur a person must touch two electrically isolated (separate) enclosure sections not two sections on the same enclosure.

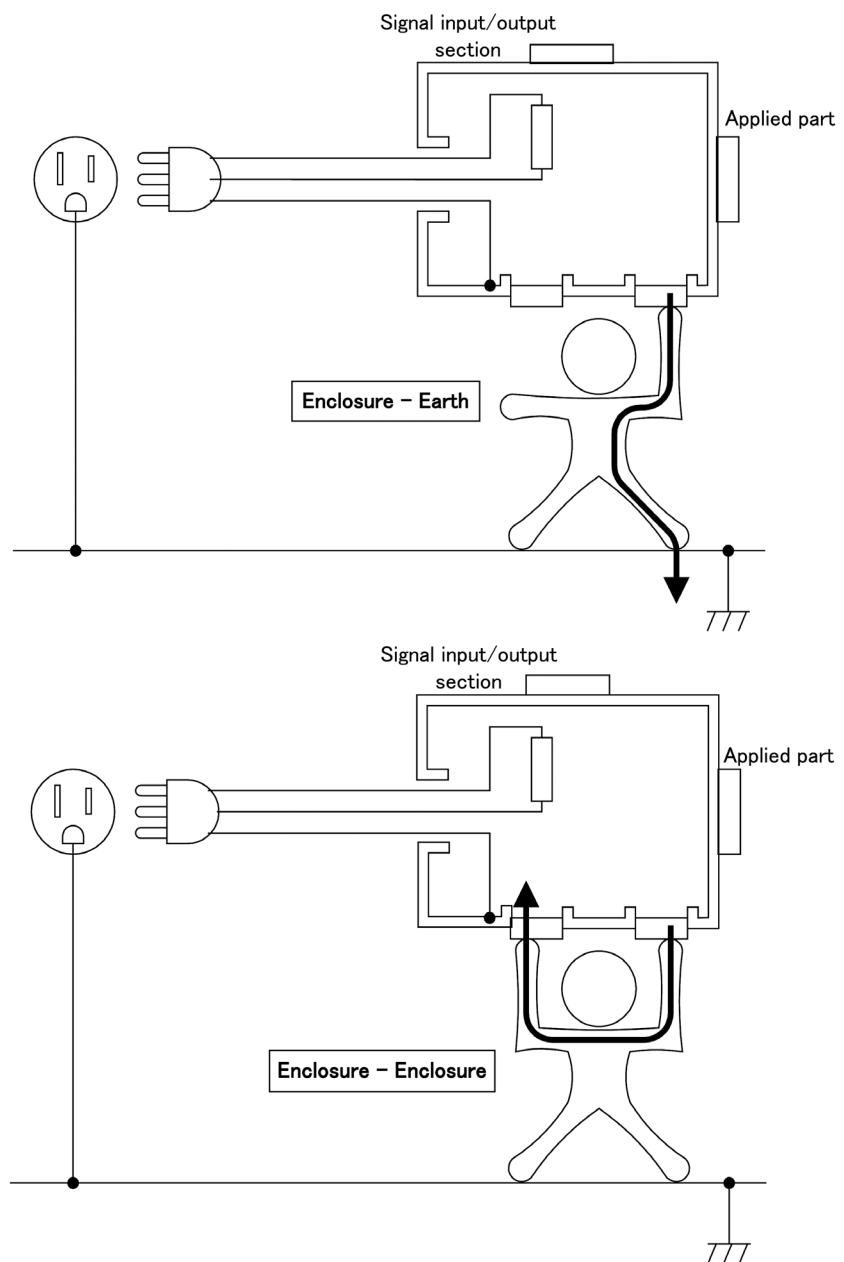

Patient auxiliary current

Patient auxiliary current is current that flows through an "applied part - human body - applied part" path. Regardless of the medical equipment class, type of applied parts, and signal input/output selection, all medical equipment with multiple applied parts must undergo this measurement.

Make both AC and DC measurements for this type of leakage current.

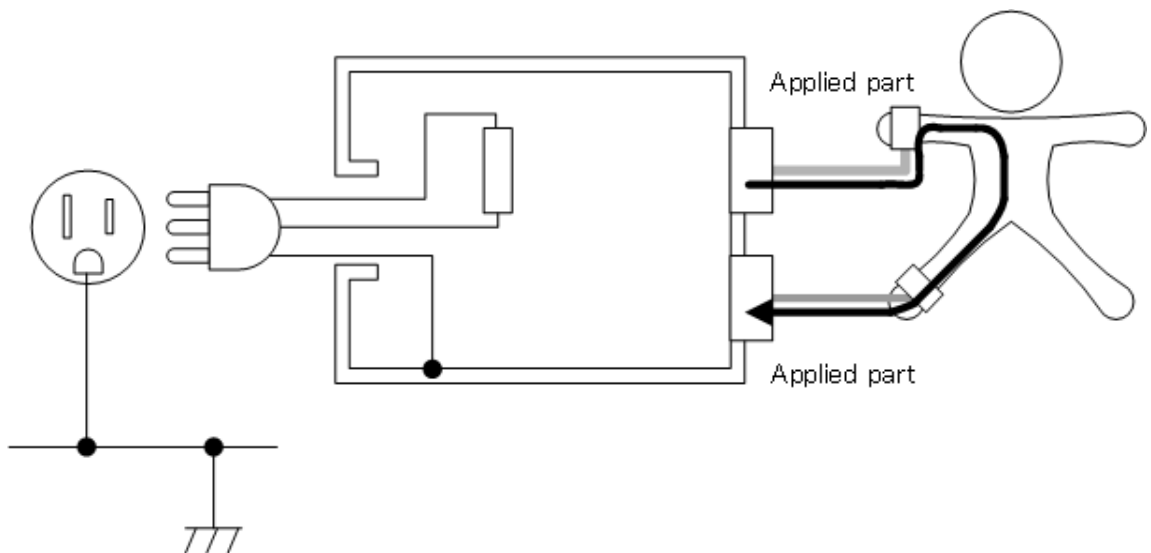

Patient leakage current measurement (Patient connection - Earth)

This is electric current that flows through an "*applied part* → human body → ground" path.

Regardless of medical equipment class, type of *applied parts* and *signal input/output section*, all medical equipment with *patient connections* must undergo this measurement.

Make both AC and DC measurements for this type of leakage current.

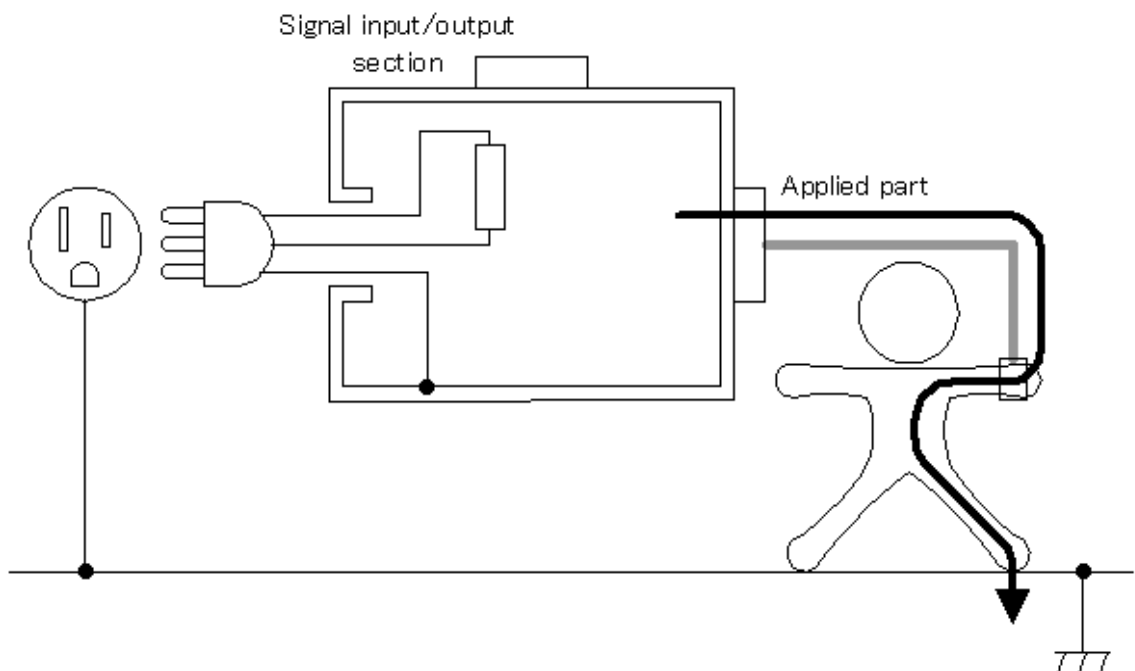

1.6 Types of Leakage Current Measurement

Patient leakage current measurement (external voltage on a SIP/SOP)

This is electric current that flows through an "applied part → human body → ground" path. Measure medical instruments with a *signal input/output section* and *applied parts* other than F-type. Measure assuming that medical equipment with a broken *signal input/output section* is connected. Instead of connecting damaged medical equipment to generate a *single-fault condition*, input a voltage that is 110% of the rated voltage.

(Use the T3 terminal on the instrument)

IEC 60601-1:2005 3rd Edition stipulates that the connection of damaged medical equipment does not constitute a *single-fault condition*, but handles it as a *normal condition*.

NOTE

JIS T0601-1:1999 treats patient leakage current II as patient leakage current I plus a *single fault condition*.

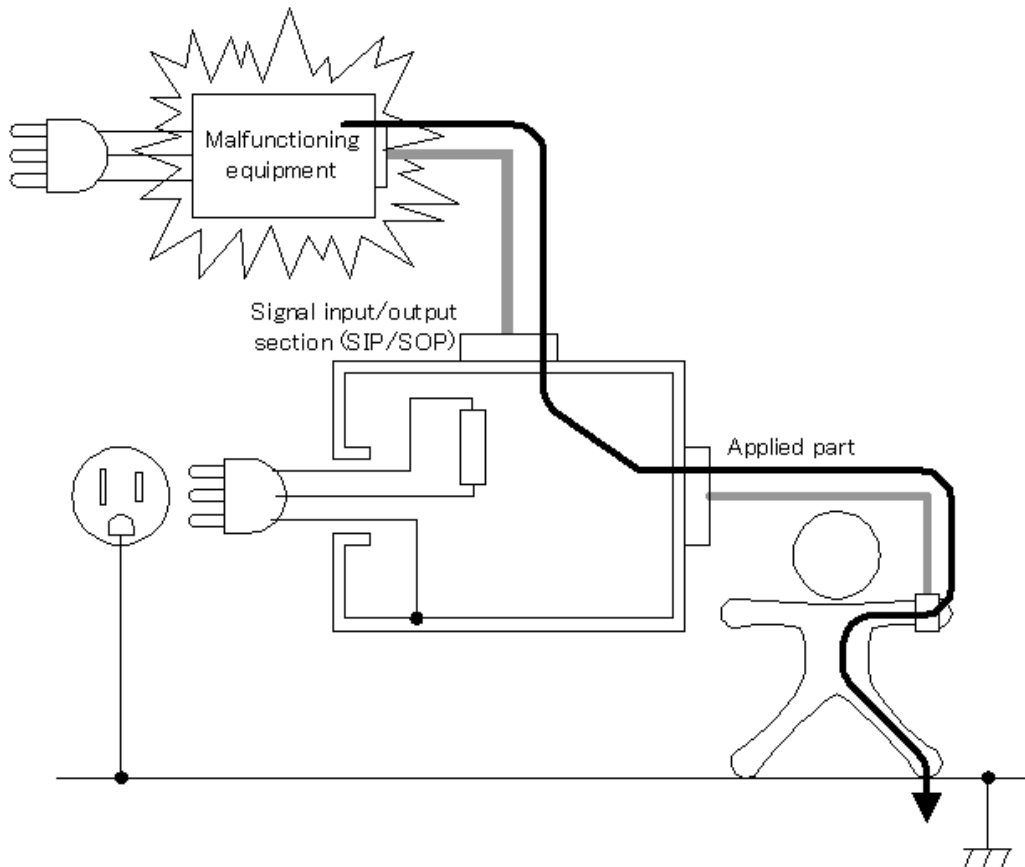

Patient leakage current measurement (external voltage on a specific F-type applied part)

This is electric current that flows through an "*applied part* of malfunctioning medical equipment → human body → *F-type applied part*" path.

The measurement of this leakage current is required only for medical devices with an *F-type applied part*. Instead of connecting damaged medical equipment to generate a *single-fault condition*, input a voltage that is 110% of the rated voltage.

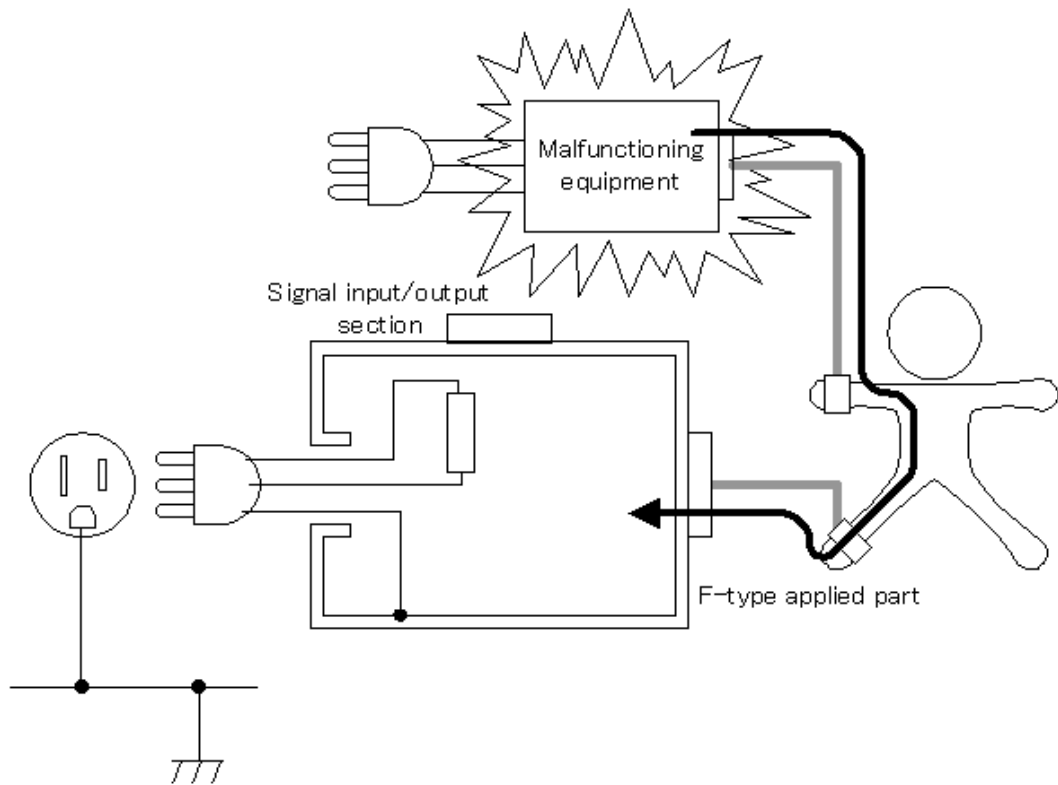

1.6 Types of Leakage Current Measurement

Patient leakage current measurement (external voltage on metal accessible part not protectively earthed)

Additions to IEC 60601-1:2005 3rd Edition

Patient leakage current is current that takes the following route: "metal accessible part not protectively earthed → *applied part* → human body → Earth." Use this standard to measure medical equipment with *patient connection* of *applied parts* that are not protectively earthed (B-type or BF-type) and with metal accessible parts that are not protectively earthed.

Instead of connecting damaged medical equipment to generate a *single-fault condition*, input a voltage that is 110% of the rated voltage to metal accessible parts not protectively earthed. (Use the T3 terminal on the instrument)

This test is not required for *CF-type applied parts*.

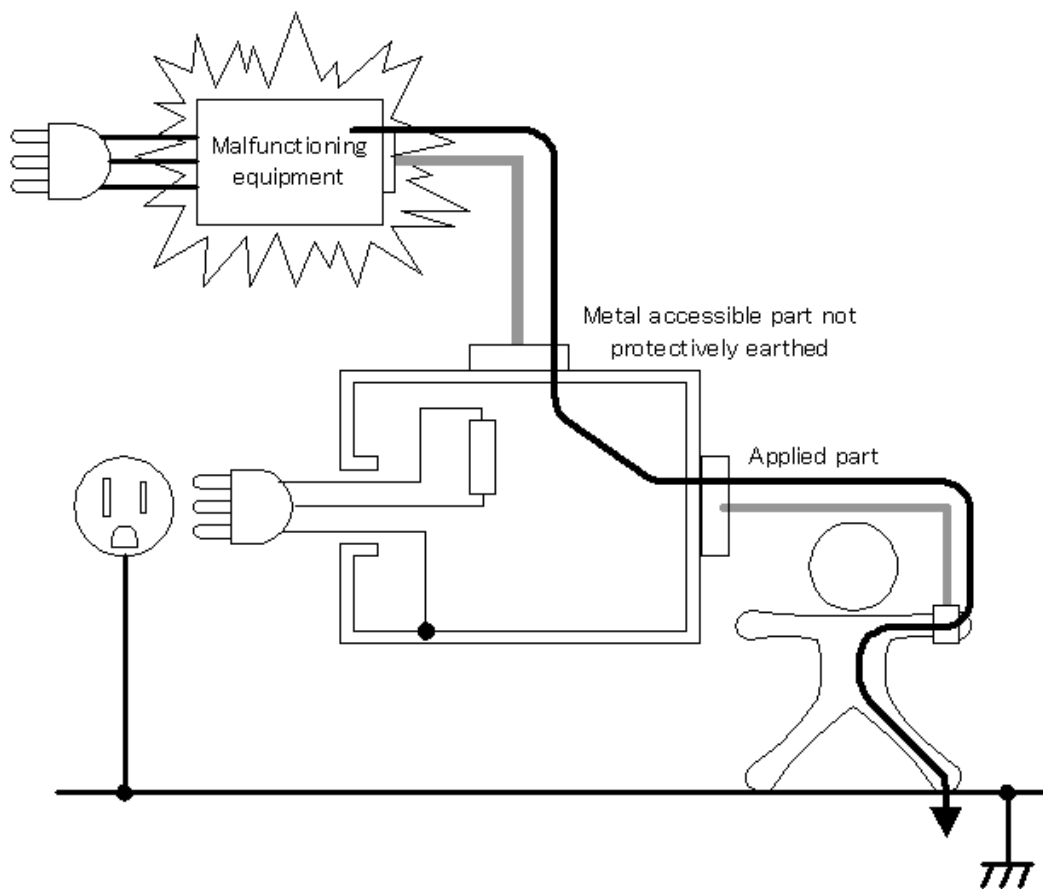

Total patient leakage current measurement

1

Chapter 1 Overview

Total patient leakage current is the total of all leakage current to or from *patient connections* of all the same type of *applied parts* (*B-Type*, *BF-Type* and *CF-Type applied parts*) simultaneously connected. When there are two or more *patient connections* that go to different functions and are not electrically connected together, the total patient leakage current for *B-Type applied parts* must be measured.

If required, measure all patient leakage current components (*patient connection* - earth, external voltage on an SIP/SOP, external voltage on an *F-type applied part*, external voltage on a metal accessible part that is not protectively earthed.)

(The figure shows patient - earth.)

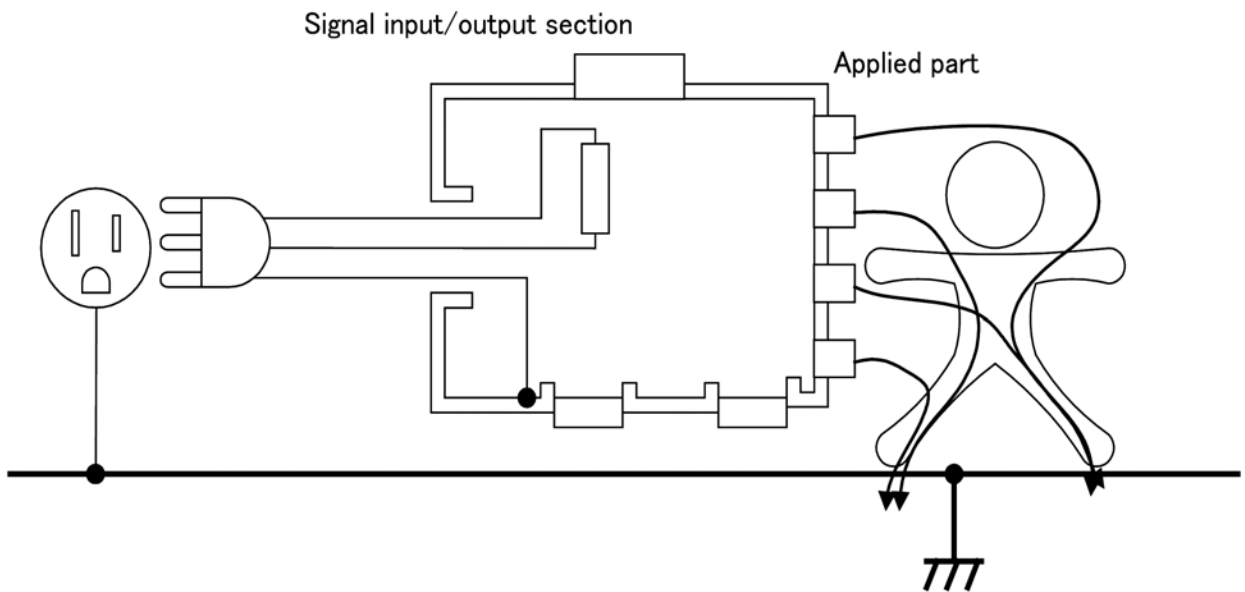

1.6 Types of Leakage Current Measurement

Protective conductor current measurement

A protective conductor current measurement measures the electric current that flows through a protective earth conductor (grounding wire) during normal operating conditions.

Like Earth leakage current, class II equipment does not have a protective earth wire and therefore does not require measurement of protective conductor current.

To measure the protective conductor current, place a resistor with a resistance so small as to be negligible in the protective earth wire circuit.

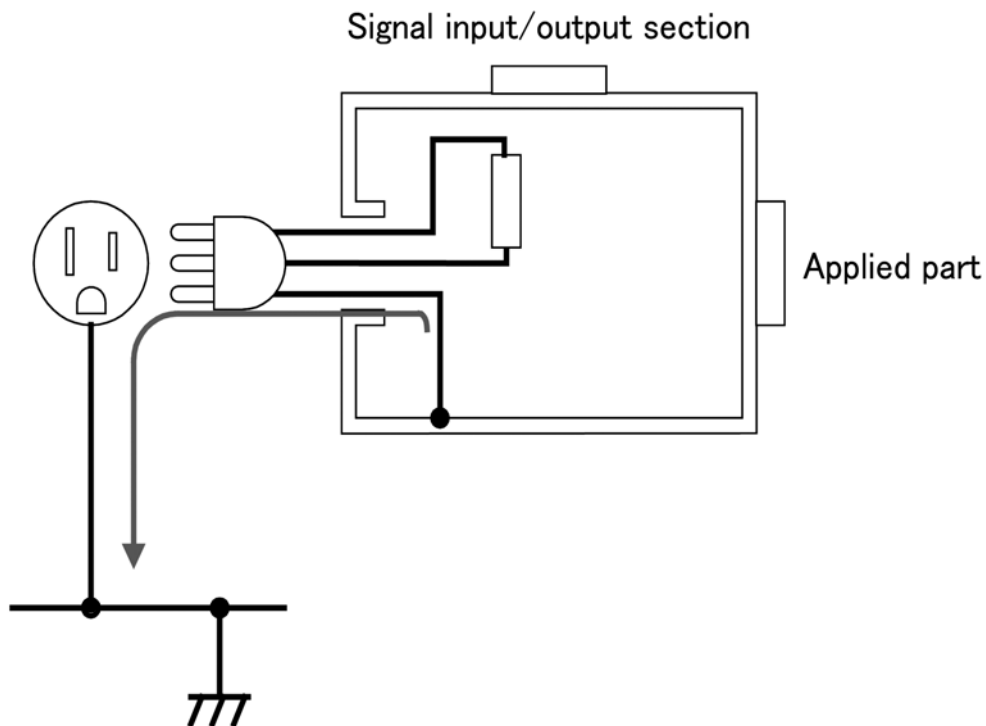

List of Leakage-Current Measurement Items

	Measurement	Normal condition	Single-fault condition	(Description of fault)	(Other conditions)
General electrical equipment	Touch current Enclosure - Line	○	○	1. One wire in the power cord is disconnected. 2. protective earth conductor is disconnected*	Situation other than touch current (Enclosure - Line) is applicable 1. Functional grounding wire is disconnected 2. Grounding wire for patient connection and power supply circuit for measurement are disconnected 3. A voltage that is 110% of the rated voltage is applied between an isolated signal input/output section and earth (Not medical equipment)
	Touch current •Enclosure - Earth •Enclosure - Enclosure	○	○		
Medical electrical equipment	Earth leakage current	○	○	1. One wire in the power cord is disconnected.	1. Functional grounding wire is disconnected (Class I only) 2. Grounding wire for patient connection and power supply circuit for measurement are disconnected (Class I only)
	Patient leakage current (Patient connection - Earth)/ (Patient leakage current I)	○	○	1. One wire in the power cord is disconnected. 2. The protective earth conductor is disconnected.	1 Functional grounding wire is disconnected 2. Grounding wire for patient connection and power supply circuit for measurement are disconnected
	Patient leakage current (external voltage on a SIP/SOP)/ (Patient leakage current II)	○	○	1. One wire in the power cord is disconnected. 2. The protective earth conductor is disconnected.	1. Functional grounding wire is disconnected 2. Metal accessible part not protectively earthed and grounding wire is disconnected 3. A voltage that is 110% of the rated voltage is applied between an isolated signal input/output section and earth
	Patient leakage current (external voltage on a specific F-type applied part)/ (Patient leakage current III)	×	×		1. A voltage that is 110% of the rated voltage is applied between an F-applied part and earth. (Does not qualify as a single fault condition under IEC 60601-1: 2005 3rd Edition.) 2. Metal accessible part not protectively earthed and grounding wire is disconnected 3. Functional grounding wire is disconnected
	Patient leakage current (external voltage on metal accessible part not protectively earthed)	×	×	1. The protective earth conductor is disconnected.	1. Applied to metal accessible part not protectively earthed 2. Functional grounding wire is disconnected
	Patient auxiliary current	○	○	1. One wire in the power cord is disconnected. 2. The protective earth conductor is disconnected.	Functional grounding wire is disconnected

* Measurement with a disconnected protective earth conductor is applicable only to Class-I equipment.

1.6 Types of Leakage Current Measurement

ST5540/ST5541 List of functions

	item	ST5540	ST5541
Network	Network A	○	○
	Network B1	○	–
	Network B2	○	–
	Network C	○	○
	Network D	○	○
	Network E	○	○
	Network F	○	○
	Network G	○	○
Testing leakage current mode	Earth leakage current	○	○
	Touch current	○	○
	Patient auxiliary current	○	–
	Patient leakage current	○	–
	Total patient leakage current	○	–
	Free current	○	○
	Enclosure - Earth leakage current	○	○
	Enclosure - Enclosure leakage current	○	○
	Enclosure - Line leakage current	○	○
	Patient leakage current I	○	–
	Patient leakage current II	○	–
	Patient leakage current III	○	–
Major functions	Power on polarity switching function	○	○
	Rated current 20 A	○	○
	Function for checking for blown fuses	○	○
	Frequency band switching	○	–
	110% voltage output terminal (T3 terminal)	○	–
	S10, S12, S13, E terminal	○	–

Instrument Labels and Screens

Chapter 2

2

Chapter 2 Instrument Labels and Screens

2.1 Instrument Labels and Functions



Front Panel

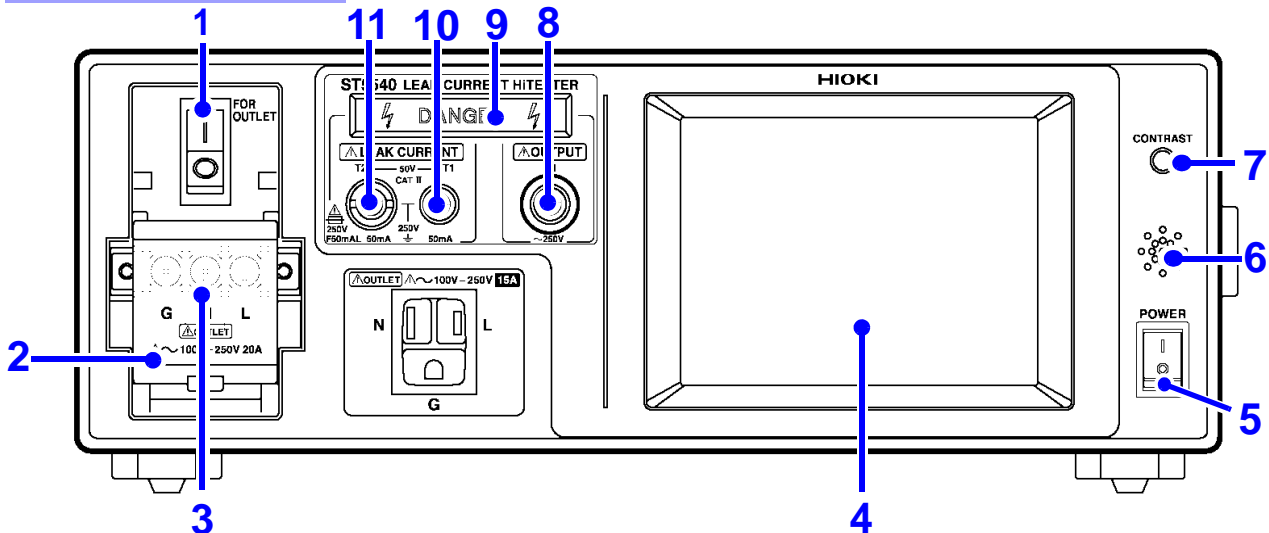

1. Circuit breaker

Detects overcurrent in the power line for equipment under test and activates a protective device.
(Rated current : 20 A)

- | : ON (for normal measuring operation)
- : OFF (idle condition or when overcurrent protection device has been triggered)

See (p. 31)

2. Terminal block cover

Covers the terminal block to prevent electric shock.
Turn the circuit breaker off (○) before opening the cover.

See (p. 37)

3. Terminal block

Outputs voltage based on the power supplied to [LINE IN] (p. 25).

Also used to connect the power cord of equipment under test.

See (p. 36)

4. Liquid crystal display unit (LCD)

Five-inch liquid crystal display unit with a touch panel function.

Also provided with input key functions.

The backlight (p. 136) can be set to turn OFF automatically.

5. Power switch

Turns the main instrument ON and OFF.

See (p. 38)

6. Buzzer

Generates a beep sound when a key is pressed, and activates a warning buzzer.

See (p. 135)

7. Contrast adjustment dial

Used to adjust screen contrast.

Turning the dial to the right darkens the display; turning to the left lightens the display.

Use this dial when the display requires adjustment.

8. 110% voltage output terminal (terminal T3)

Insulates the voltage supplied to [LINE IN] (p. 25) using the built-in transformer and outputs a 1:1 voltage from terminal T3. Effective only when B1 or B2 network is selected. (only ST5540)

See (p. 75)

NOTE Input 110% of the rated voltage to [LINE IN] (p. 25) using the isolation transformer to use the T3 terminal. The T3 terminal will only output a 110% of the rated voltage when the same voltage is input to [LINE IN].

9. Warning lamp

Lights when high voltage is generated at the T1 - T3 terminals.

10. Measuring terminals (terminals T1)

11. Measuring terminals (terminals T2)

Used to measure leakage current other than Earth leakage current. The T2 terminal is provided with a protective fuse.

(fuse rating : 250 V, F50 mA)

See (p. 75), (p. 282)

Rear Panel

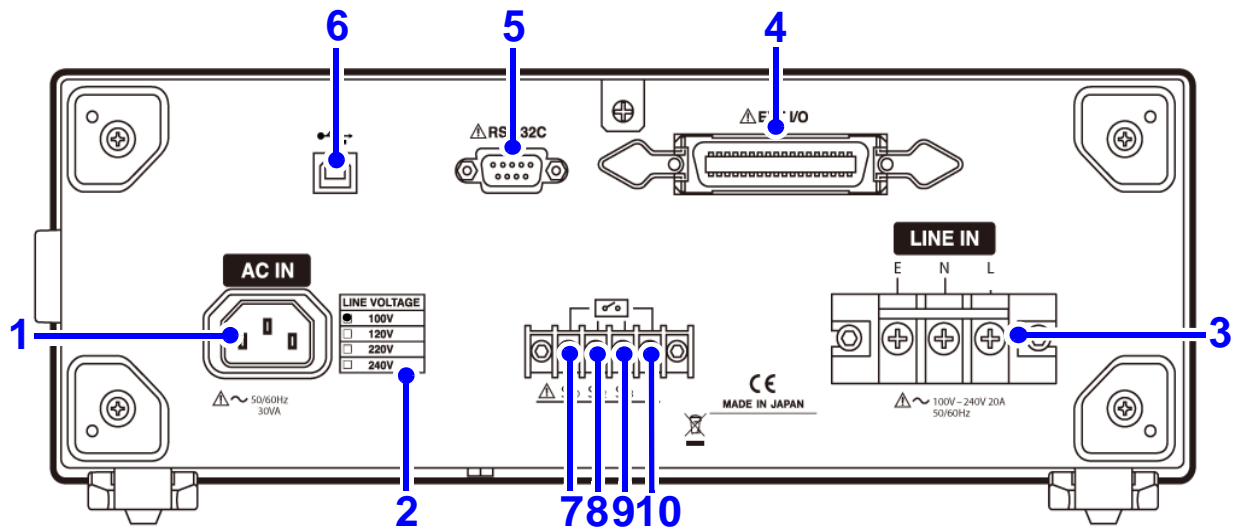

1. Power inlet [AC IN]

Used for input of the power supply to operate the instrument.
Used to connect the power cord provided.

2. Power source rating

Marked with a black dot (●) in the power line voltage specification section.

3. Inlet for power line of equipment under test [LINE IN]

Used for input of the power supply for equipment under test.

Used to connect the power cord provided.
(Maximum rating: 250 V/20 A)

NOTE Correct measurements are not made when no voltage is input to [LINE IN].

See (p. 33)

4. EXT I/O connector

Input/output terminal for external control.
(The proper connector is required for connection.)

See (p. 245)

5. RS-232C connector

Used to connect an RS-232C cable or 9444 Connection Cable (for the 9442 Printer).
(The 9442 Printer, 9444 Connection Cable, and other accessories are optional products.)

See (p. 139)

6. USB connector

Used to connect a USB cable.
(The USB terminal provides communication functions but no storage capacity.)

See (p. 139)

7. S10 terminal*

Terminal for connecting function ground terminal and power supply system for measurement. Connect to E (earth) for [LINE IN].

Enables connection to earth during leakage current measurements. (only ST5540)

See (p. 35)

8. S12 terminal*

Terminal for connecting patient connection to ground for power supply circuit for measurement. Connect to E (earth) for [LINE IN].

Enables connection to earth during leakage current measurements. (only ST5540)

See (p. 35)

9. S13 terminal*

Terminal providing ground connection for metal accessible part not protectively earthed. Connect to E (earth) for [LINE IN]. Enables ground connection during leakage current measurements. (only ST5540)

See (p. 35)

10. E terminal

Connected to E (earth) of [LINE IN].

This is a permanent connection that cannot be changed.

* Setting enabled only when B1 or B2 network is selected.

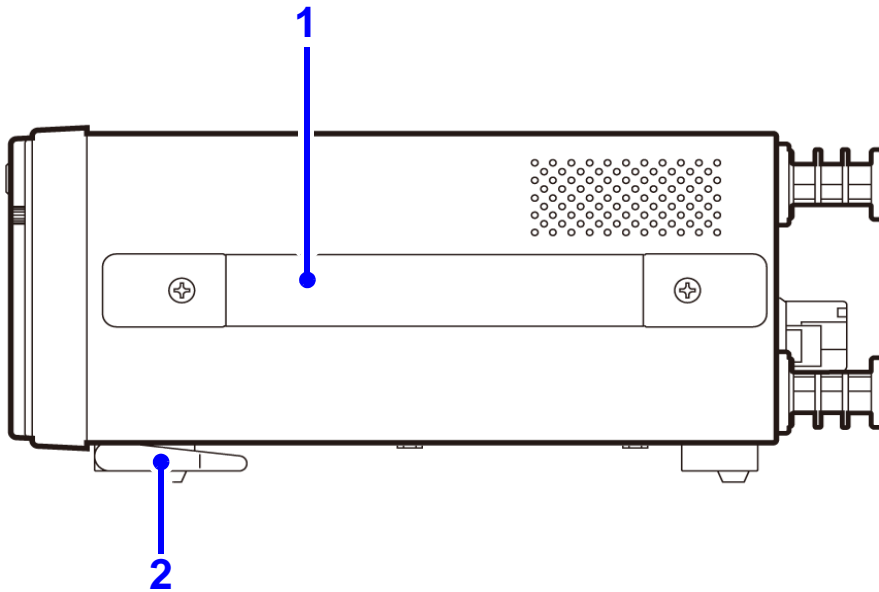
Side Panel**1. Handle**

Used to carry the instrument.

2. Stand

Used to tilt the instrument.

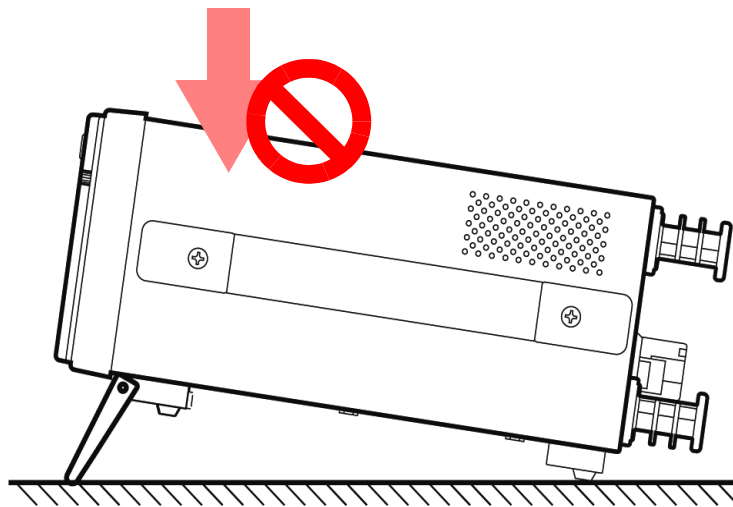
**! CAUTION**

Take the following precautions to prevent electric shock accidents and damage to the instrument.

- Use M3 screws to attach rack mount brackets after removing the feet.
- When the rack mount brackets are removed to restore the instrument to its original condition, be sure to use the original screws.
- The screws used must not penetrate more than 5 mm below the metal panels.
- Do not apply heavy downward pressure with the stand extended. The stand could be damaged.

2.2 Screen configuration outline

The following example shows screens that appear after selecting network A. (Screens for networks C to G look the same as the screen for network A only the network keys differ. Due to the larger number of measurement mode keys, selecting network B1 opens three initial screens and selecting B2 opens four initial screens.)

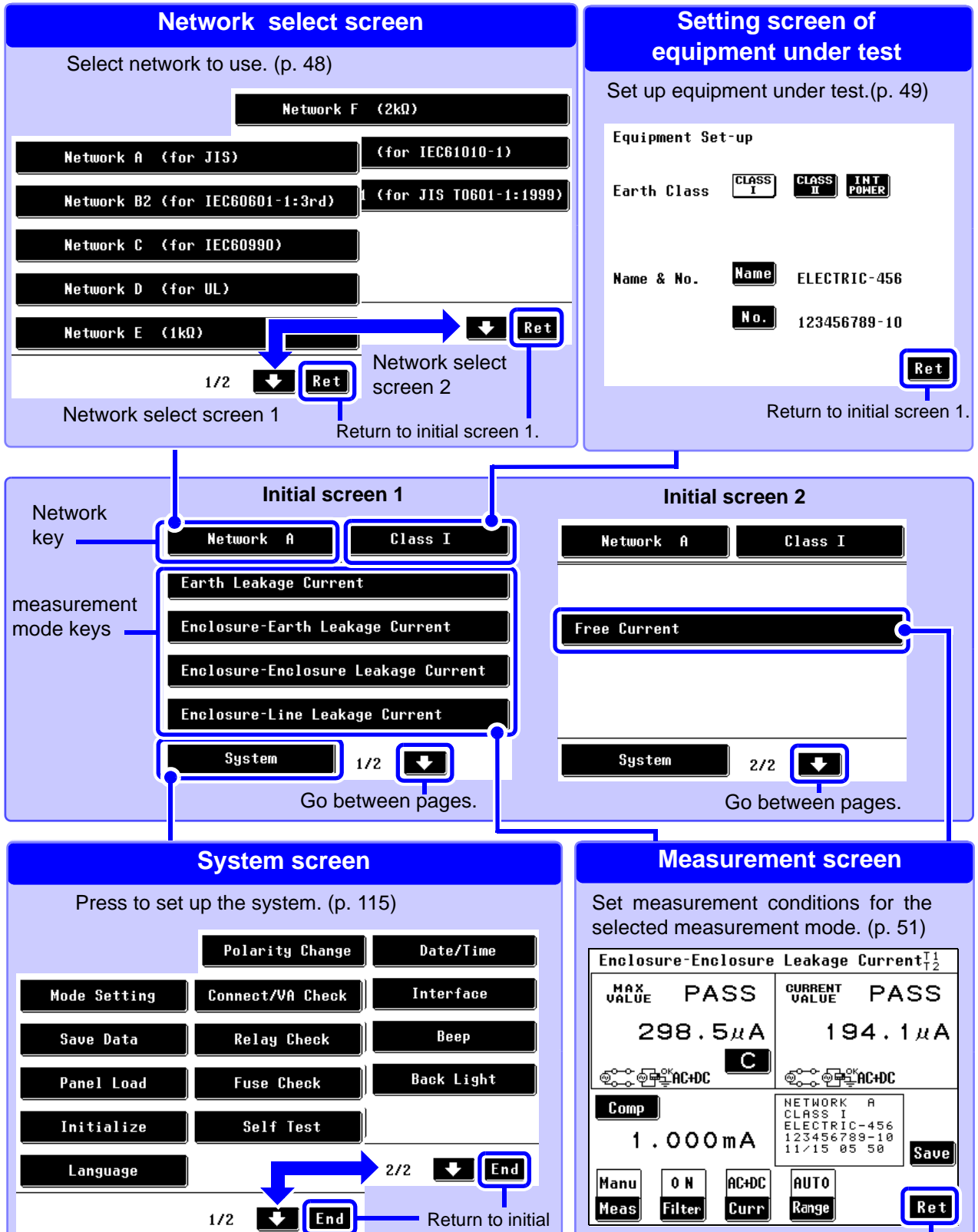

2.2 Screen configuration outline

Shared measurement screen displays

The following describes shared measurement screen displays.
 (Screen example : Earth leakage current measurement screen)

Result of comparison between maximum value and allowable value.

- PASS** : Maximum value is equal to or less than the Upper limit value.
- FAIL** : Maximum value is greater than the Upper limit value.
- LOW** : Maximum value is equal to or less than the Lower limit value.

Range Up:
 Measurements exceed the guaranteed accuracy range. (PASS or FAIL is not determined)

Range Down:
 Measurements drop below the guaranteed accuracy range. (PASS or FAIL is not determined)

Result of comparison between current measurement value and allowable value.

- PASS** : Current measurement value is equal to or less than the Upper limit value.
- FAIL** : Current measurement value is greater than the Upper limit value.
- LOW** : Current measurement value is equal to or less than the Lower limit value.

Range Up:
 Measurements exceed the guaranteed accuracy range. (PASS or FAIL is not determined)



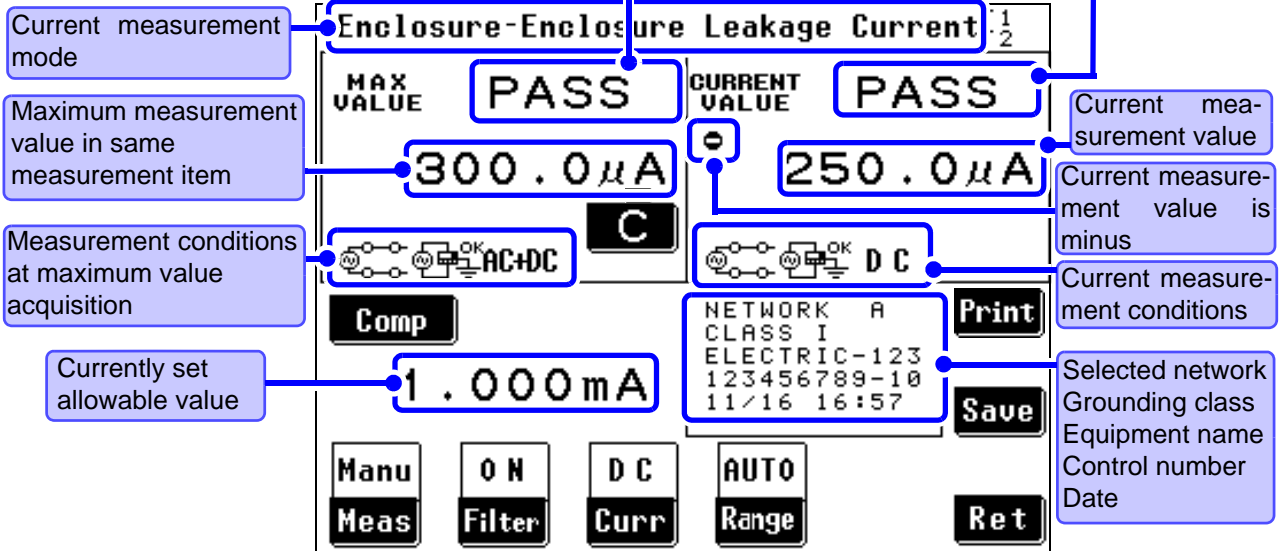





Range Down:
 Measurements drop below the guaranteed accuracy range. (PASS or FAIL is not determined)









Measurement screen (manual measurement)

Key description

Shared keys

	Clears the maximum value. Unless this key is pressed, the maximum value is not cleared even if measurement conditions are changed in the same measurement mode. Changing the measurement mode clears the maximum value.
	Displays the allowable value setting screen. See "4.6 Setting the Allowable Value" (p. 61)
	The measurement condition setup screen appears. See "4.8 Changing the Measurement Method (Auto/Manual)" (p. 67)
	Displays the filter setting screen. (When a filter selection is available) Used to turn the filter ON and OFF, or change the setting of the filter. See "4.5 Setting the Filter" (p. 59)
	Displays the screen for setting the target current. (When an target current selection is available) See "4.7 Selecting the Type of Target Current" (p. 64)
	Displays the screen for setting the measurement range. Switches the range between Auto and Hold. See "4.4 Setting the Measurement Range (Auto/Hold)" (p. 54)
	Displays the screen for selecting data to be saved. See "6.4 Saving Measurement Data (As required)" (p. 102)
	Starts transmitting data to the 9442 Printer (option). This key is displayed only when the interface setting is set to "Printer". See "6.6 Printing Measurement Data (as required)" (p. 108)
	Exits the currently selected measurement mode, and returns to the system screen.

Specific keys (not displayed for some measurement method)

	Applies a high voltage to a test lead connected to the T3 terminal. See "6.3 Measurement examples" (p. 83)
	Starts automatic measurements. See "6.2 Making automatic measurements" (p. 82)
	During automatic measurement : Stops automatic measurements. During application : Stops output of high voltage. During printing : Terminates printing. See "6.2 Making automatic measurements" (p. 82) See "6.3 Measurement examples" (p. 83) See "Printing" (p. 111)
	Displayed only when the frequency range is set from 0.1 Hz. Press this key to adjust the measurement value. (Measurement values are automatically adjusted when set from 15 Hz.)
	Displayed when patient leakage current (patient - earth) and internally powered equipment are selected. See "Measuring the internally powered equipment 1" (p. 91)
	See "Measuring the internally powered equipment 2" (p. 92)

2.3 About the Touch Panel

The HiTESTER uses a touch panel for setting and changing all of the measurement conditions. Gently touch the black keys on the screen to make settings and selections. A key turns white and has a concave look when selected. In this manual, lightly touching a soft key area on the screen is termed "pressing" a key.

CAUTION

Do not use excessive force on the touch panel, and do not use sharp objects that could damage the touch screen.

Keys on screen

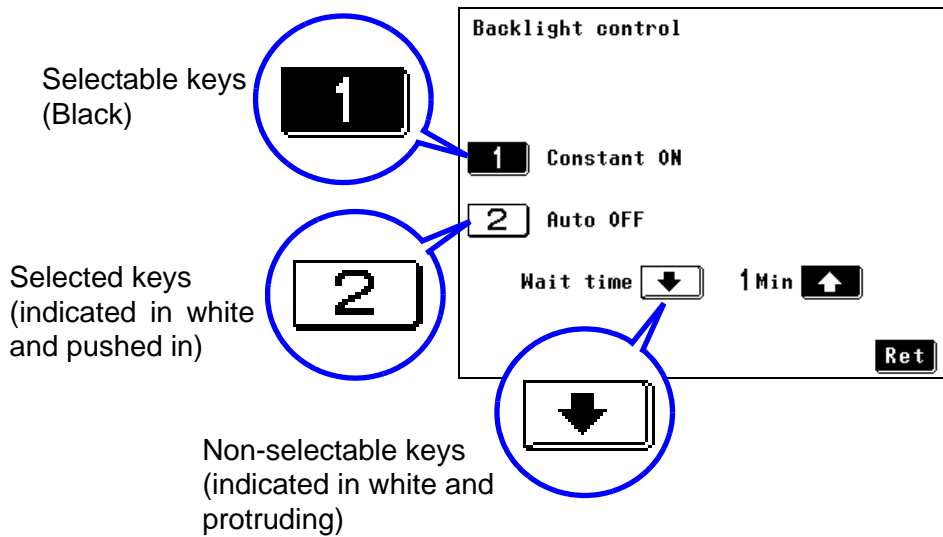

NOTE

Keys whose key captions appear as dotted lines are keys for measurement modes not required for the selected grounding class.

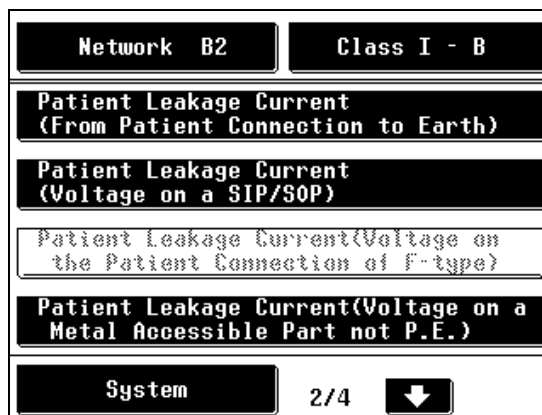

Setting Preparations

Chapter 3

3.1 Power switch, breaker ON/OFF

3

Chapter 3 Setting Preparations

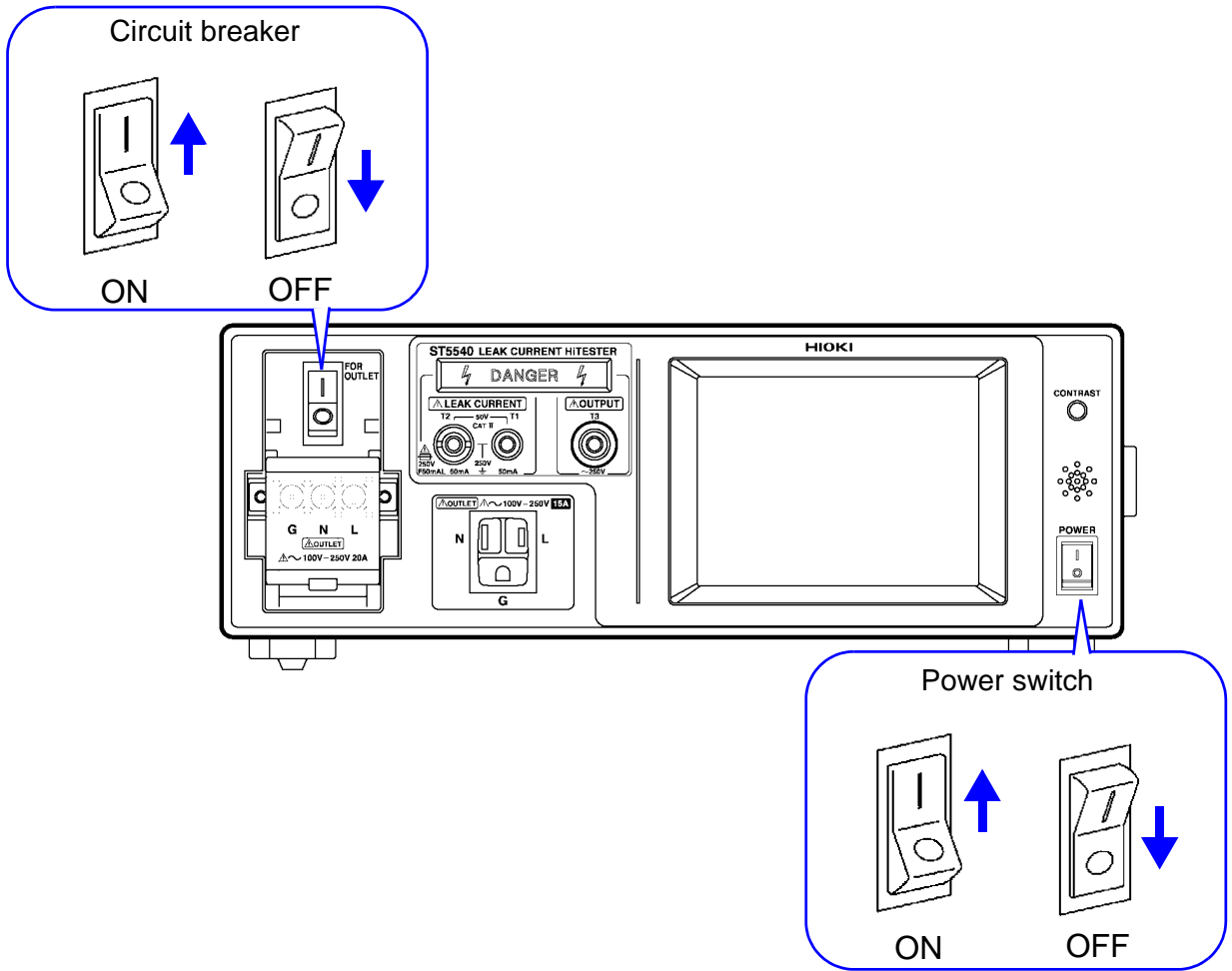

3.2 Connecting the Power Cord



Connecting the instrument power cord

! WARNING

- Before turning on the instrument, confirm that the voltage of the power source matches the voltage specification indicated on the instrument's power connector ([AC IN]). (The voltage specification (100, 120, 220 or 240 V) ordered by the customer is marked with a black dot ● in the line voltage column on the rear panel.) Note that using the power supply with improper voltage may damage the instrument and result in electrical hazards.

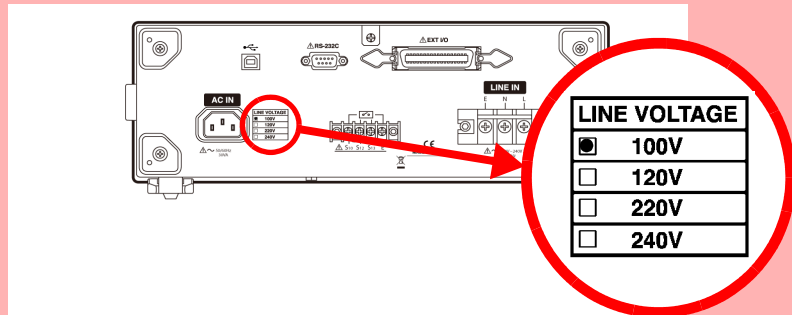

- To avoid electrical accidents and to maintain the safety specifications of this instrument, connect the power cord provided only to a 3-contact (two-conductor + ground) outlet.

! CAUTION

To avoid damaging the power cord, grasp the plug, not the cord, when unplugging it from the power outlet.

Preparation items : Power cord for main instrument

1. Confirm that the main power switch on the front panel of the main instrument and the circuit breaker are turned off.

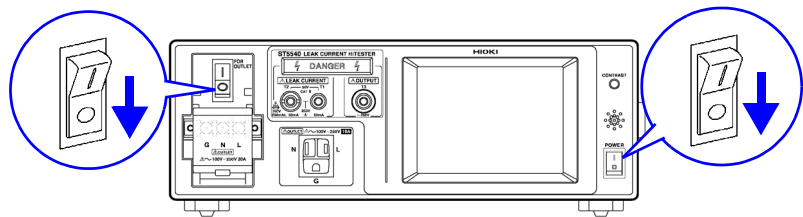

2. Connect the power cord to the [AC IN] power inlet on the rear panel of the main instrument, and insert the power cord plug into a power outlet that supplies the voltage specified for the instrument.

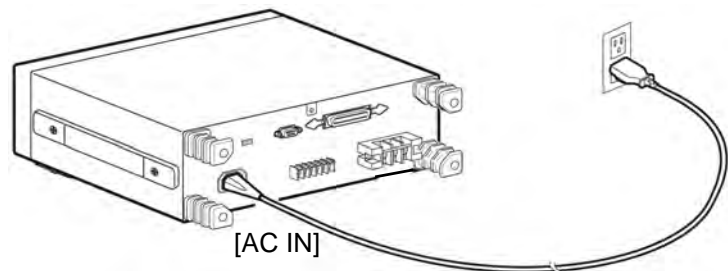

NOTE

The ground (G) for the power inlet [AC IN] is a protective earth conductor and is

Connecting the power cord of the equipment under test

Preparation items : Power cord for equipment under test
Isolation transformer (separately purchased)

1. Confirm that the main power switch on the front panel of the main instrument and the circuit breaker are turned off.

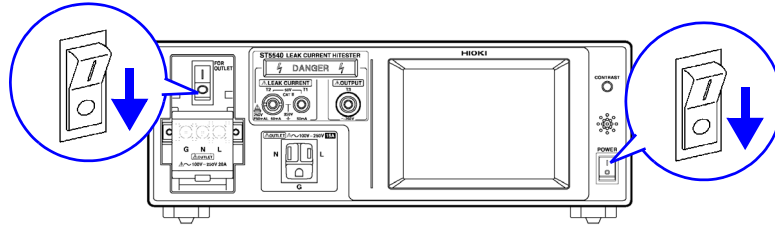

2. Connect the supplied power cord of the equipment under test to the [LINE IN] line power terminal block for equipment under test on the rear panel of the instrument.
3. Connect the plug of the power cord to the isolation transformer.
4. Connect the isolation transformer plug to a power supply with the voltage specified by the equipment under test.

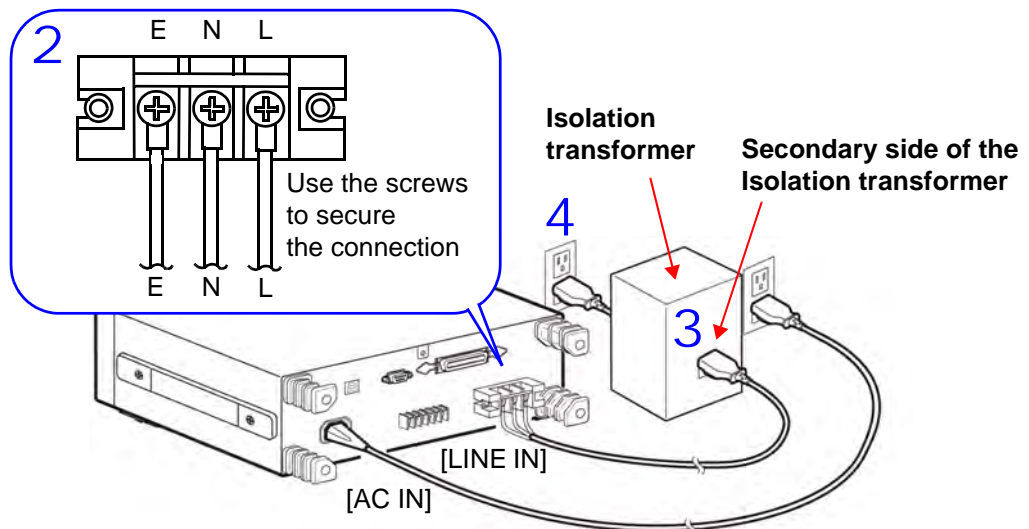

! WARNING

- When the power on polarity switching function is used, be sure not to connect the neutral wire on the secondary side of the isolation transformer to ground. If it is connected to ground, a ground fault will occur.
- Use a voltmeter or voltage detector to make sure that terminal E [LINE IN] is at ground potential (approx. 0 V). Failure to make this confirmation could lead to electric shock or damage the instrument or the equipment under test.
- When connecting the power cord of the equipment under test to the [LINE IN] terminal, use a cord suitable for the capacity of the equipment under test. Using a power cord with another rating may result in fire.

3.2 Connecting the Power Cord

NOTE

- Use of network B1 or B2 requires the connection of an isolation transformer capable of outputting a voltage equivalent to 110% of the rated power supply voltage of the equipment under test.
- When network C is selected, an isolation transformer is required. However, when the power on polarity switching function is not used, connect the neutral wire on the secondary side to ground. When the function is used, not to connect the neutral wire to ground.
- The [LINE IN] and [AC IN] power supplies are isolated from each other.
- Use the cable supplied with the ST5540 and ST5541 instruments to connect the equipment under test [LINE IN]. Do not connect any other electrical appliance to this inlet.
- The [LINE IN] terminal cannot be used to connect a single-phase three-wire or center-grounded power supply (for example, a stabilized power supply).
- Nor will the input of 110% of a rated 250 V power supply voltage be a problem.

Description of isolation transformer

The standard requires that an isolation transformer is used for performing leakage current measurements.

Should the equipment under test break down during measurements, unforeseen current could be generated resulting in tripping the earth leakage breaker. Such an event could shut down other electrical equipment used in the same facility, which could cause a serious accident. Since an isolation transformer isolates equipment under test from the earth leakage breaker, equipment breakdown will not have an impact on the earth leakage breaker or on any other equipment.

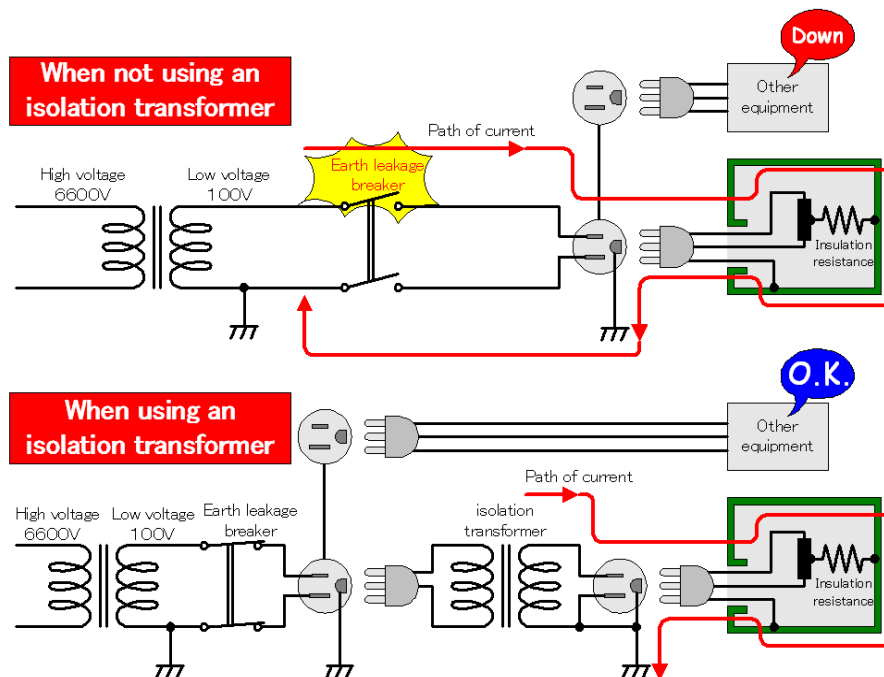

NOTE

Voltage fluctuations of $\pm 10\%$ from the rated supply voltage are taken into account. Nor will the input of 110% of a rated 250 V power supply voltage be a problem.

Making connections to terminals S10, S12 and S13

1. Make sure that the connection to [LINE IN] is correct.

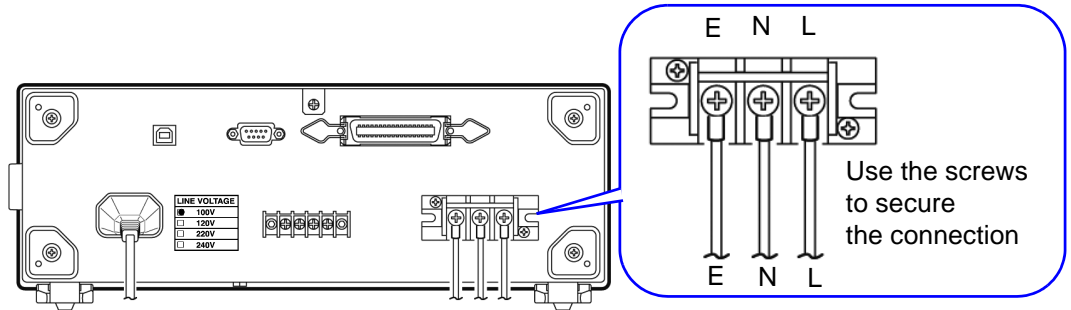

! WARNING

If the wrong connection has been made to [LINE IN], the E terminal may output the power supply voltage. Since there is then a risk of electric shock, make sure that the [LINE IN] connection is correct before making connections to the S10, S12 and S13 terminals.

2. Make connections to S10, S12 and S13 to prepare for a leakage current test.

- | | |
|--------------|---|
| S10 terminal | For testing connection of function ground terminal to ground of power supply system for measurement |
| S12 terminal | For testing connection of patient connections to ground of power supply system for measurement |
| S13 terminal | For testing connection of metal accessible part not protectively earthed to ground |

Example: Connecting S10 terminal to functional earth terminal

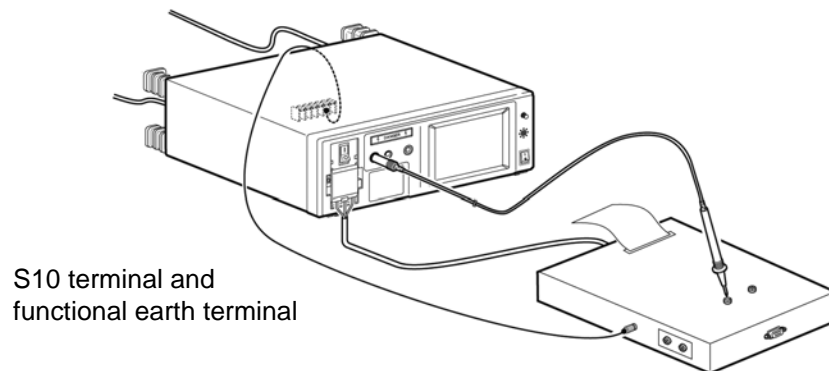

NOTE

- S10, S12 and S13 are internally connected to the [LINE IN] E terminal (E terminal is permanently connected to the [LINE IN] E terminal) and correct measurements are not possible unless a power supply is connected to [LINE IN].
- When you do not know whether the S10, S12 or S13 terminal should be used, refer to the documentation supplied with the equipment under test.

3.3 Connecting equipment under test to the instrument



The actual connection procedure will vary with the power supply of the equipment under test. A cord to connect the instrument and the equipment under test is not supplied. Use a power cord that suits the power supply of the equipment under test.

WARNING

- To avoid electrical accidents, confirm that all connections are secure. The increased resistance of loose connections can lead to overheating and fire.
- To avoid electric shock or damage to the equipment, always observe the following precautions when connecting to external terminals. Always turn off the power to the instrument and to any devices to be connected before making connections. Be careful to avoid exceeding the ratings of external terminals and connectors. During operation, a wire becoming dislocated and contacting another conductive object can be serious hazard. Make sure that connections are secure and use screws to secure the external connectors.
- The permissible current for the terminal block is 20 A. Current exceeding this limit will trip the breaker and shut down the power supply of the equipment under test.

Connect the terminal

When connecting the HiTESTER to equipment under test with a power cord, use the terminal block.

CAUTION

- L (Line), N (Neutral) and G (Ground) are indicated on the terminal block of the instrument, and the contacts of the power cord of the device to be measured are denoted L, N and G. Connect the wires as shown below. Other wiring configurations may cause electric shock or damage.
- If the power cord does not include an Ground (G) line, connect only the L and N terminals.

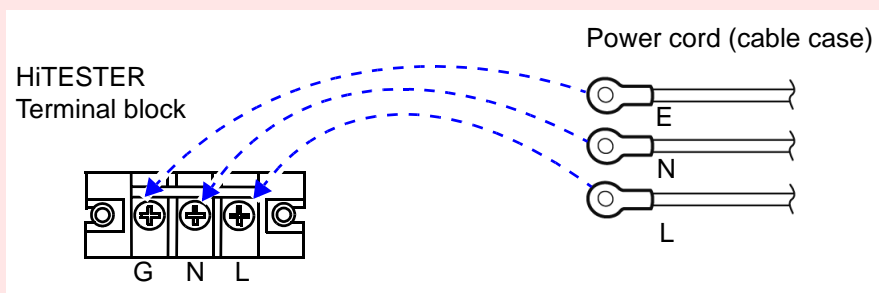

- When reinstalling the terminal block cover, hang the connected wires straight down to prevent the wires from being pinched by the cover. Otherwise, the wires may be disconnected when pinched by the cover.
- To avoid the risk of electric shock and short-circuiting, use the supplied power cord to connect the measurement line and voltage input terminal.

3.3 Connecting equipment under test to the instrument

Connecting wires to the terminal block

1 Turn off the instrument and set the breaker to Off.

See "Turning Power Off" (p. 40)

See "3.1 Power switch, breaker ON/OFF" (p. 31)

2

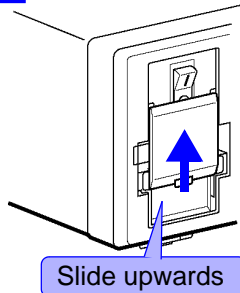

Slide upwards

3

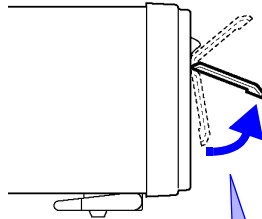

Raise the cover.
(The cover will stay in place when raised to a certain height)

4

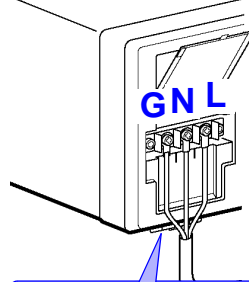

Check that the G, N and L terminals are correctly connected and make sure the wires are properly secured. Turn on the instrument.

G : For grounding wire connection
(Class-I equipment only)

N : For neutral wire connection

L : For live wire connection

5

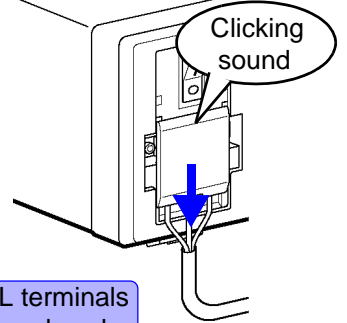

Clicking sound

Fit the right and left projecting portions of the terminal block cover into the panel slit. Slide the cover downwards until it clicks into place

6 Turn on the HiTESTER.

See "3.4 Turning Power On and OFF" (p. 38)

Using a wiring adapter

Obtain and use a wiring adapter as shown below.

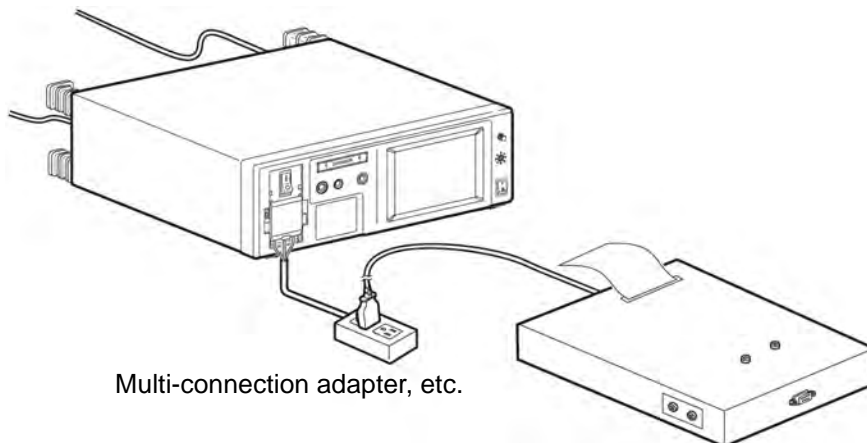

Multi-connection adapter, etc.

! WARNING

- Turn off the circuit breaker connecting a wiring adapter or equipment.
- The terminal block continuously output the voltage based on the power supplied to [LINE IN].

NOTE

Leakage current will increase with the use of multi-connection adapters, etc.

3.4 Turning Power On and OFF

Turning Power On

! WARNING

- Before turning on the instrument, confirm that the voltage of the power source matches the voltage specification indicated on the instrument's power connector ([AC IN]). (The voltage specification (100, 120, 220 or 240 V) ordered by the customer is marked with a black dot ● in the line voltage column on the rear panel.)

Note that using the power supply with improper voltage may damage the instrument and result in electrical hazards.

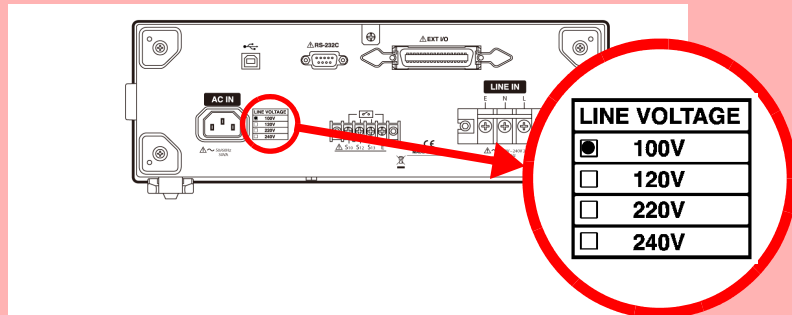

- To avoid electrical accidents and to maintain the safety specifications of this instrument, connect the power cord provided only to a 3-contact (two-conductor + ground) outlet.

! CAUTION

- Before turning on the power switch, confirm that the circuit breaker is turned off. Even if the instrument was turned off in fault mode (i.e., disconnection of one wire in the power line) at last use, the instrument will be initialized to normal condition when the power switch is turned on. Therefore, the terminal block outputs voltage.
- The instrument can operate continuously for 30 minutes at maximum load. Measurements that continue for longer than 30 minutes may raise internal temperature and thereby trip the circuit breaker.

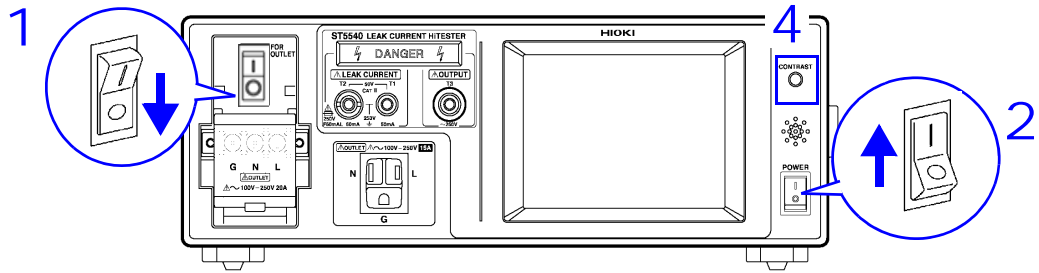

1. Confirm that the circuit breaker is turned off.
(If the instrument is turned on when the circuit breaker is On, the circuit breaker may be triggered.)
2. Turn on the power switch (ON: I) on the front panel.
3. The LCD shows the opening message. Then the wiring check screen appears.
4. Use the contrast adjustment dial to set the LCD for easy viewing.
5. Turn the circuit breaker On and press **Renew** to check wires connected to LINE IN. (**Check** appears only when wiring is incorrect. Press **Check** for advice.)
6. Press **Next** to open the fuse check screen.
See "7.5 Checking Fuses (During Earth leakage current and protective conductor current measurements)" (p. 123)
7. Pressing **Next** in the fuse check screen opens the relay check screen.
See "Relay Check" (p. 41)
8. Pressing **Next** in the relay check screen, the network select screen appears by default.
If the instrument was turned off with the LCD showing the measurement screen at last use, that measurement screen appears.
If the instrument was turned off with the LCD showing a screen other than the measurement screen, the initial screen appears.
9. After turning the power on, let the instrument warm up for about 20 minutes before starting measurement operation.

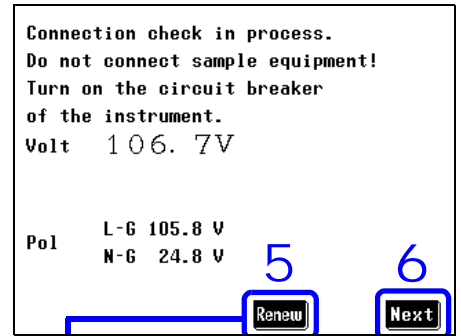

Wiring check screen
Check again.

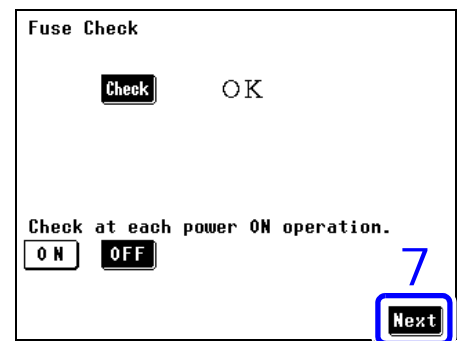

Fuse check screen

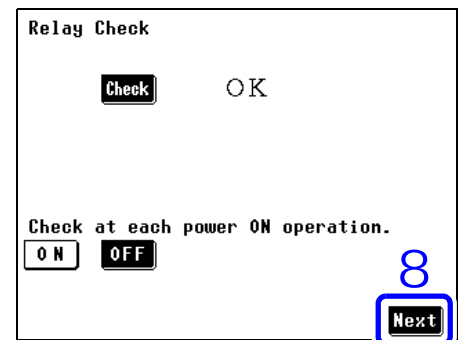

Relay check screen

NOTE

When "Check at each power ON operation" is enabled on the connection/VA check screen, the connection/VA check screen appears after the power switch is turned on.

See ".Inspecting line power supply for the equipment under test" (p. 42)

(If the power on polarity switching function was on when the instrument was last turned off, a message to check isolation transformer connection and precautions appear before the wiring check screen.)

When the grounding class of the equipment under test is set to internally powered equipment, **INT POWER** is displayed, and after the initial measurement, the voltage value will not be renewed as long as "Renew" is not pressed.

Turning Power Off



Always turn off the power switch of equipment under test before turning off power of the instrument to avoid damaging the equipment under test. The instrument uses an internal relay for switching the power line to equipment under test and turning off the power switch of the instrument opens all lines and turns off the equipment under test.

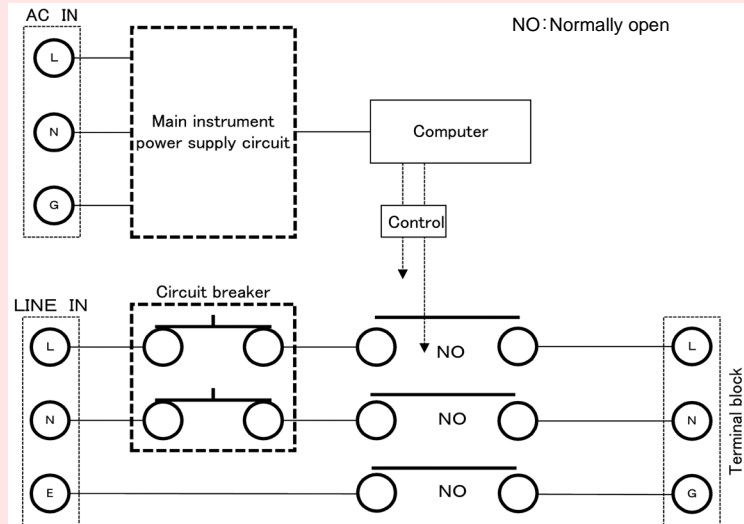

Condition of power line for equipment under test with the main instrument power switch turned OFF (schematic diagram)

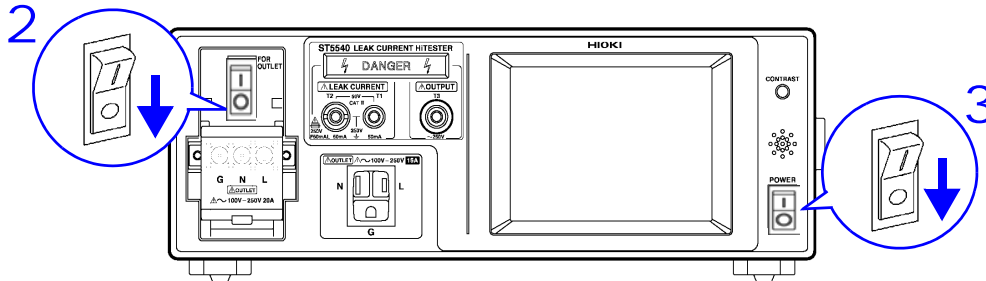

1. Turn off the power switch of equipment under test connected to the terminal block.
2. Turn off the circuit breaker.
3. Turn off the power switch (OFF: ○) on the front panel.
When the power switch is turned off, the measurement conditions are saved. In case of power supply failure (e.g., power outage), the instrument restores the conditions held immediately before power failure occurred.

3.5 Pre-Test Inspection



Before using the instrument the first time, verify that it operates normally to ensure that no damage occurred during storage or shipping. If you find any damage, contact your dealer or Hioki representative.

Pre-connection inspection

Does any cable insulation appear damaged, or is bare metal exposed?	Do not use if damage is present, as you could receive an electric shock. Contact your dealer or Hioki representative if you find any damage.
Is damage to the instrument evident?	
Does the power supply use single-side-grounded wiring?	When using a center-grounded wiring type power supply (for example, a stabilized power supply), you may not be able to perform all checks accurately.

Power-on confirmation

1 Relay Check



The internal configuration of the instrument makes it possible that a device under test connected during a relay check may be exposed to unexpected voltage that could damage it.

Enables the user to check whether the measurement network and internal circuit relays work normally.

- (1) Press **System** on the initial screen to display the system screen.
- (2) Press **Relay Check** to open the relay check screen.
- (3) Press **Check** to start a relay check.
- (4) An "OK" appears when the check ends without error.
- (5) Press **Ret** to return to the system screen.

NOTE

Supply power via [LINE IN] and turn the circuit breaker On as a relay check will otherwise not operate normally. Always confirm this before performing a relay check. Do not connect a device under test during a relay check.

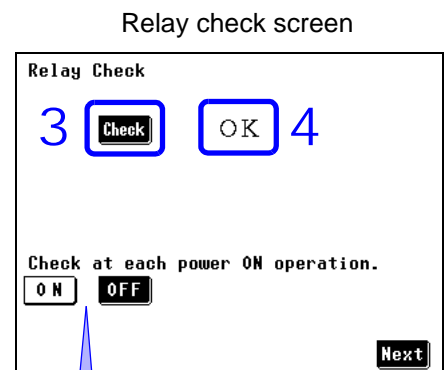

Press **ON** or **OFF** to select whether the check is to be conducted each time power is turned.

An "OK" is displayed

See next page.

A "NG" is displayed

A "NG" indication indicates that the measurement network or an internal relay does not work normally. As the instrument is not in normal working order, contact your dealer or nearest Hioki sales office.

3.5 Pre-Test Inspection

2 Fuse inspection (when using modes other than Earth leakage current and protective conductor current modes)

The current detection circuit in the instrument contains a fuse. Should the fuse blow due to incorrect wiring or an over-current condition, the instrument may no longer be able to detect current. Before use, make sure that the fuse is not blown.

Required items

- A device for measuring impedance (for example, a tester)
- (1) Select network E in the Network Select screen and select Enclosure - Enclosure leakage current.
 - (2) Use a tester to measure the impedance between the T1 and T2 terminals on the front panel. (Or place the tip of test leads connected to the T1 and T2 terminals on the tester to measure.)
 - (3) Check that an impedance value of $1015 \pm 10 \Omega$ is obtained.

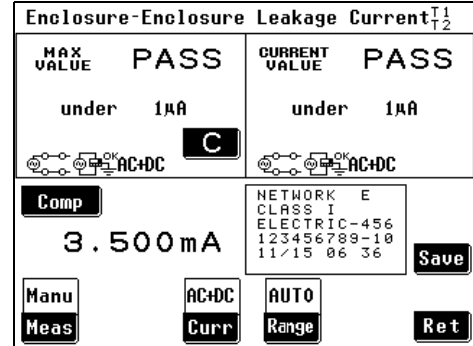

Network E : Enclosure-Enclosure leakage current measurement screen

NOTE

When the tester is connected to the T1 and T2 terminals, the instrument measures the leakage current going through the tester.

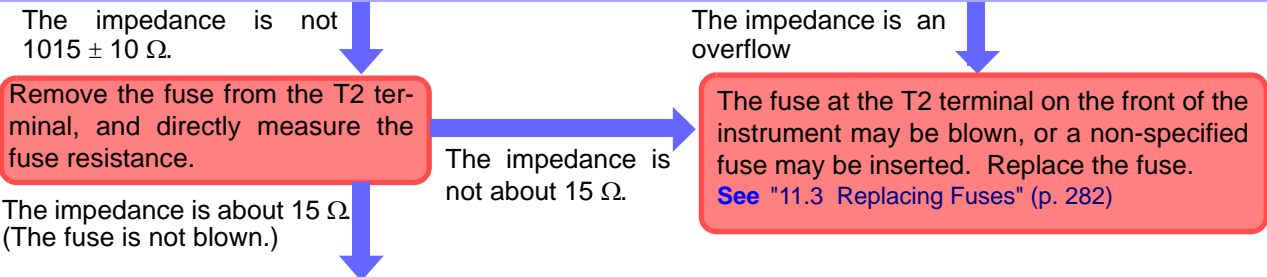

3 Inspecting line power supply for the equipment under test

Check the line power supply of the equipment under test.

- (1) Press **System** in the initial screen.
- (2) Turn on the circuit breaker of the instrument. (p. 31)
- (3) Press **Connect/VA check** to display the connection/VA check screen.
- (4) The check is made automatically.
- (5) Press **Ret** to return to the system screen.

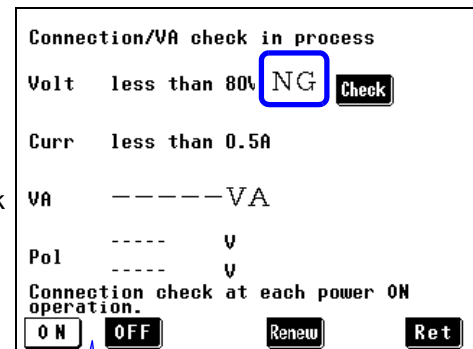

NOTE

Supply power via LINE IN and turn the circuit breaker On as a connection / VA check will not otherwise operate normally. Always confirm this before performing a connection / VA check.

Press **ON** or **OFF** to select whether the check is to be conducted each time power is turned.

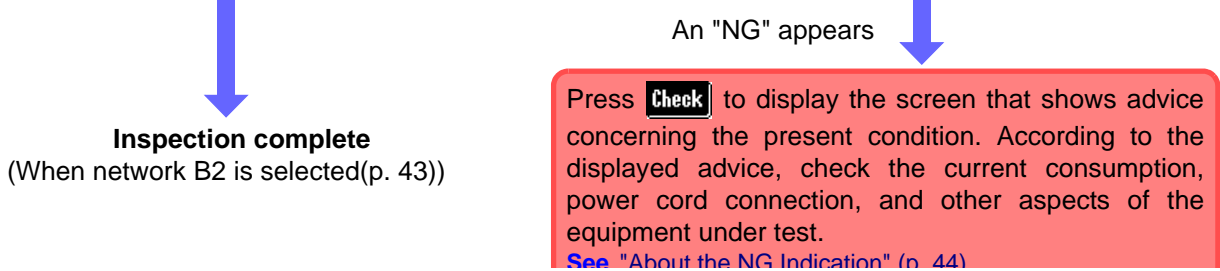

Checking measurement frequency

When network B2 is selected

The frequency range setting of the instrument is 0.1 - 1 MHz allowing the user to select 0.1 Hz - 1 MHz or 15 Hz - 1 MHz. An 0.1 Hz - 1 MHz setting will slow down the response of internal circuits and increase measurement time. Therefore perform the following tests to check the frequency range setting when using a B2 network. (Default setting: 15 Hz - 1 MHz)

- (1) Press **System** in the initial screen.
- (2) Press **Frequency Range**.
- (3) Press **2** and set a frequency range setting of 0.1 Hz.
(Press **Ret** to confirm and return to the system screen.)
- (4) The **CAL** appears when 0.1 Hz frequency range is set.
Press **CAL** and adjust the value
- (5) Measure the leakage current of the equipment under test and record the measured value.
(Perform this measurement for 1 or 2 minutes.)
- (6) When recording ends, perform operations in step (1) and (2) again and press **1** and set a frequency range setting of 15 Hz.
- (7) Measure the leakage current of the equipment under test and compare this value with the value obtained in the 0.1 Hz - 1 MHz setting.
Unless the two values differ substantially, the customer's equipment under test does not produce any leakage current and the 15 Hz - 1 MHz setting is enough for any subsequent measurement.

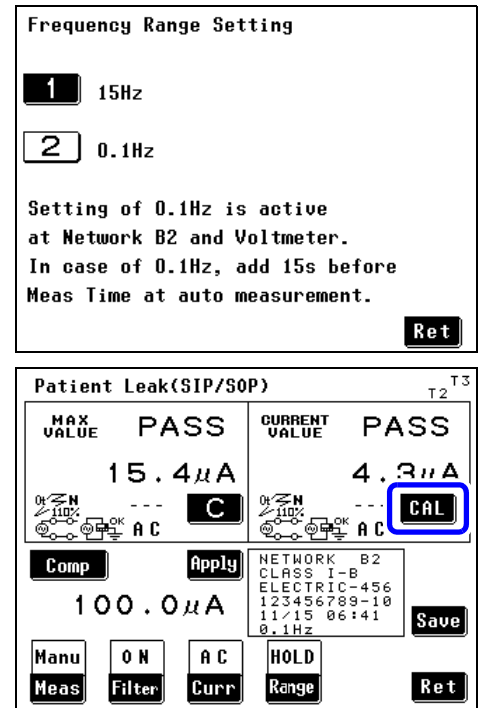

NOTE

Check the frequency range setting at regular intervals.

- Use the 0.1 Hz setting only for measurements in the B2 network.
- Selecting a network other than the B2 network in an 0.1 Hz setting will invalidate the 0.1 Hz setting. (The display does not change.)
- The auto range is not available when a 0.1 Hz frequency range setting is made. Selecting auto range automatically sets the hold range. (during ACpeak measurements: 1.000 mA range; during AC/DC/AC+DC measurements: 500.0 μ A range)
- Setting the frequency range to 0.1 Hz in voltmeter mode engages the hold range (500.0 mV range).
- Setting the frequency range to 0.1 Hz when ACPeak is selected in leakage current meter mode selects ACDC.
- The CAL key appears when 0.1 Hz frequency range is set.

See "Specific keys (not displayed for some measurement method)" (p. 29)

3.5 Pre-Test Inspection

Connection/VA check screen

Indicates the voltage of power supplied to [LINE IN].

Indicates the current consumption of the equipment under test.

Indicates the power consumption.

Measures voltage between the terminals of [LINE IN] to check the polarity. Indicates the voltages between phase L and terminal G and between phase N and terminal G on the terminal block.

Press **ON** or **OFF** to select whether the check is to be conducted each time power is turned.

Check again.

```

Connection/VA check in process
Volt 106.0V
Curr less than 0.5A
VA less than 52VA
Pol L-G 105.1 V
    N-G 25.2 V
Connection check at each power ON
operation.
ON OFF Renew Ret
    
```

NOTE

When the grounding class of the equipment under test is set to internally powered equipment, **INT POWER** is displayed, and after the initial measurement, the voltage value will not be renewed as long as "Renew" is not pressed.

About the NG Indication

1. If the result of a check is judged not normal, an "NG" indication appears to the right of the corresponding item, along with a **Check** key for the display of details. (In the screen example shown on the below, the voltage is not normal (NG).)
2. Press **Check** to display the screen that shows advice concerning the present condition. According to the displayed advice, check the current consumption, power cord connection, and other aspects of the equipment under test.

```

Connection/VA check in process
Volt less than 80V NG Check
Curr less than 0.5A
VA -----VA
Pol ----- V
    ----- V
Connection check at each power ON
operation.
ON OFF Renew Ret
    
```

Under 80V. **Ret**

NOTE

The polarity check's **Check** key may be displayed for uninterrupted polarity switching wiring but does not indicate a problem with the wiring. When the uninterrupted polarity switching function has been enabled, an uninterrupted performance check (uninterrupted polarity switching wiring check) is performed before measurement to check the wiring.

Check examples

(1) If the voltage check results in NG

<p>Under 80V.</p> <p style="text-align: right;">Ret</p>	<ul style="list-style-type: none"> • Check the voltage of the power supply. • Check whether the circuit breaker is ON. • The internal fuse (power) may be blown. Check connections.
<p>Voltage exceeds 275V.</p> <p style="text-align: right;">Ret</p>	<p>The maximum allowed power supply voltage is 275 V.</p>

(2) If the current check results in NG

<p>Current exceeds 20A.</p> <p style="text-align: right;">Ret</p>	<p>Reduce the current to 20 A or less.</p>
---	--

(3) If the VA check results in NG

<p>VA exceeds 5000VA.</p> <p style="text-align: right;">Ret</p>	<p>The VA (voltage x current) must be 5,000 VA or lower.</p>
---	--

3.5 Pre-Test Inspection

(4) Polarity check results

<p>No interrupt Change is enabled. Check connection.</p> <p style="text-align: right;">Ret</p>	<p>The wiring may not be configured for uninterrupted polarity switching. Check the wiring.</p>
<p>Grounding wire may not be connected</p> <p>Power supply may not be grounded</p> <p>May be a single-phase, 3-wire system.</p> <p style="text-align: right;">Ret</p>	<ul style="list-style-type: none"> • The grounding wire may be disconnected. • The power supply may be a floating power supply. • The power supply may be a single-phase, 3-wire power source.
<p>Polarities are reversed.</p> <p style="text-align: right;">Ret</p>	<p>The polarities of the power supply are reversed. Reverse the L and N wire connections on [LINE IN]. See "Connecting the power cord of the equipment under test" (p. 33)</p>

Settings

Chapter 4

The setup procedure differs with the measurement method (Manual/Automatic).

Manual

measurement :

Perform the settings described from "4.1 Selecting a Network" (p. 48) to "4.8 Changing the Measurement Method (Auto/Manual)" (p. 67).

Automatic

measurement :

Perform the settings described from "4.1 Selecting a Network" (p. 48) to "Setting the measuring time" (p. 73).

4.1 Selecting a Network

1. After the power switch of the HiTESTER is set to ON (|), the initial screen appears.

2. Press  and then display the network select screen.

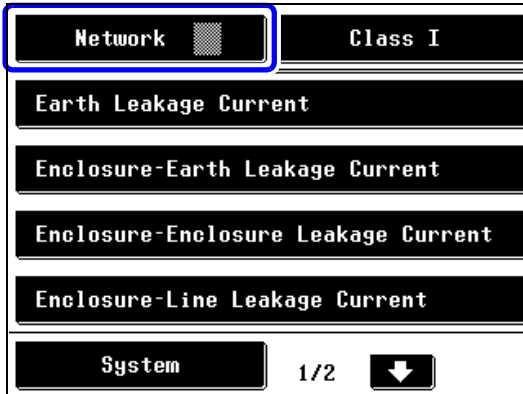

Initial screen

Press the  to switch the network selection screen.

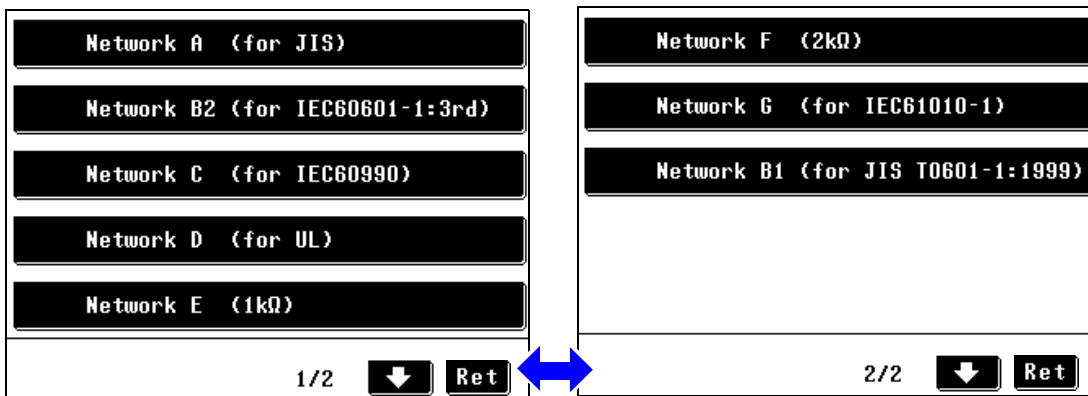

Network select screen 1

Network select screen 2

3. After the desired network is selected, the initial screen appears.

To change the network, return to the network select screen by pressing the  key.

NOTE

- The instrument normally functions as an ammeter, but will operate as a voltmeter when "voltmeter" is selected in the mode setting screen. When the network configuration not supported by networks A to G is required, your own network can be connected for testing by using the instrument as a voltmeter.

See "7.1 Setting the Mode (To use the instrument as a voltmeter)" (p. 117)

- Once a network is selected, the initial screen appears the next time power is turned on. If turning the power switch off with the measurement screen displayed, the measurement screen is redisplayed the next time power is on.

4.2 Selecting the Grounding Class of Equipment Under Test

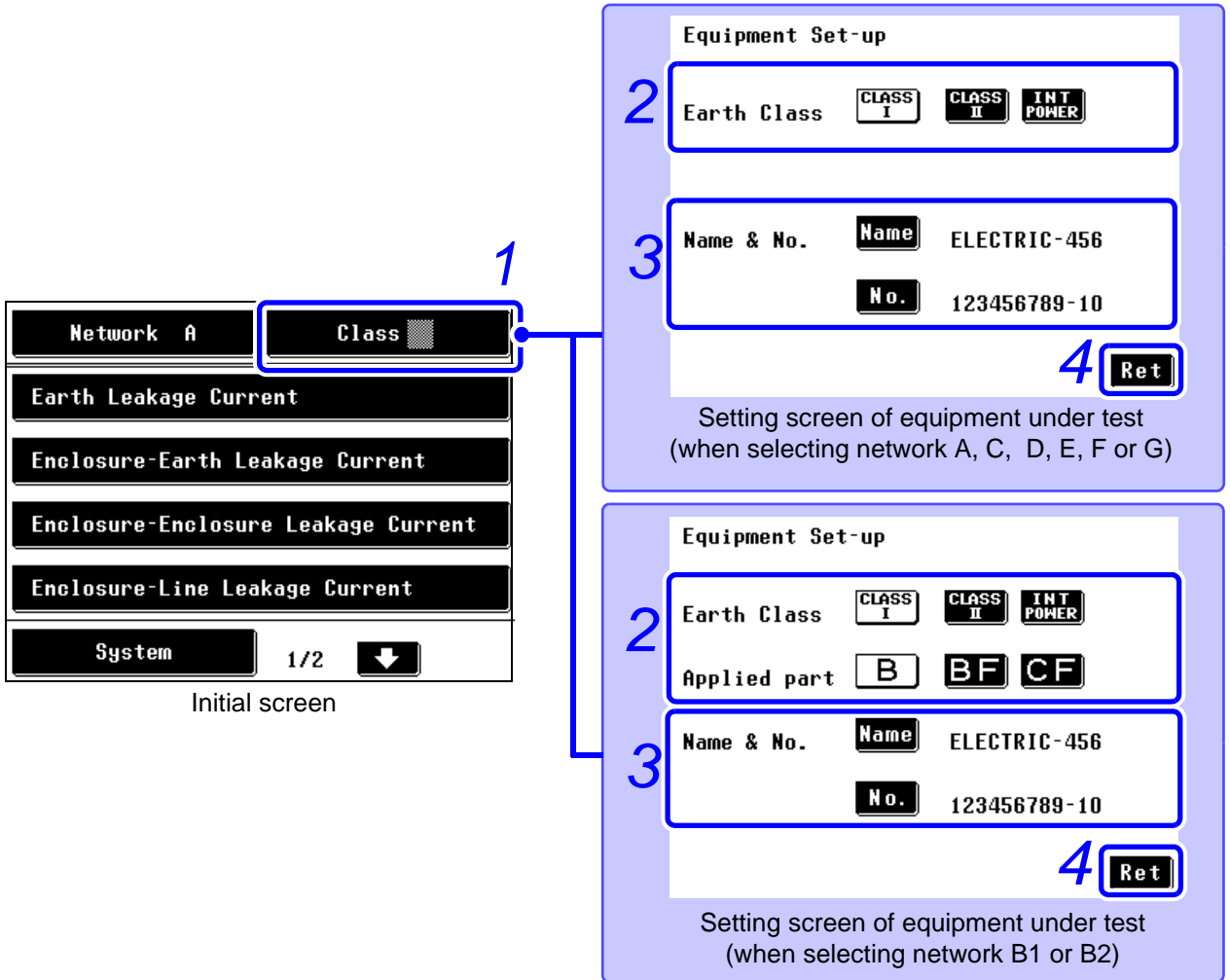

1. On the initial screen, press the **Class** key to display the setting screen of the equipment under test.

2. Set the grounding class of the equipment under test.

CLASS I	Inspection of Class-I equipment	B	Inspection of equipment with Type B applied part (when selecting network B1, B2)
CLASS II	Inspection of Class-II equipment	BF	Inspection of equipment with Type BF applied part (when selecting network B1, B2)
INT POWER	Inspection of internally powered equipment	CF	Inspection of equipment with Type CF applied part (when selecting network B1, B2)

3. To manage measurement data, register equipment name and control number. See "Registering an Equipment Name/Control Number" (p. 50)

4. Press **Ret** to return to the initial screen. The keys displayed indicate inspection items required by the selected class.

4.2 Selecting the Grounding Class of Equipment Under Test

NOTE

When the grounding class set for the equipment under test is changed, the condition settings on the measurement screen are initialized except for the allowable value factor.

When the instrument is set to internally powered equipment, even if the breaker is turned On, the power supply to the equipment under test will be interrupted (grounding connection will also be interrupted).

Registering an Equipment Name/Control Number

An equipment name and a control number can be registered. The name and number registered are included in the data that is printed or saved.

Once a name and number are registered, both are included in printed and saved data until the setting is changed.

Up to 12 characters can be entered. Since the entered information is saved along with measurement data, entering information can be useful.

1. On the setting screen of the equipment under test, press **Name** to display the alphabetic character input screen.

The input screen shows "----" by default.

Equipment Set-up

Earth Class CLASS I CLASS II INT POWER

Applied part B BF CF

Name & No. 1 Name ELECTRIC-456

4 No. 123456789-10

7 Ret

Setting screen of equipment under test

2. Enter an equipment name.

Before entering, be sure to press **CLEAR** to clear the input box.

CLEAR	Clears the equipment name or control number.
B S	Backspace.
ABC ↕ 123	Switches between the alphabetic character input screen and numeric character input screen.

ELECTRIC_

A B C D E F

G H I J K L

M N O P Q R

S T 2 J V W 3

Y Z CLEAR B S ABC ↕ 123 ENTER

Alphabetic character input screen

3. Press **ENTER** to register the input and return to the setting screen of the equipment under test.

4. Press **No.** to display the numeric character input screen.

5. Enter a control number.

6. Press **ENTER** to register the input and return to the setting screen of the equipment under test.

7. Press **Ret** to return to the initial screen.

ELECTRIC-12_

7 8 9

4 5 6

1 2 3

0 6

CLEAR B S ABC ↕ 123 ENTER

Numeric character input screen

4.3 Selecting a Measurement Mode (opens the measurement screen)

After a measurement mode is selected on the initial screen, the measurement screen appears.

NOTE

- The number of measurement modes displayed on the screen varies depending on the network and class settings selected.
- Some measurement modes may not be available for selection depending on the class and applied part settings.
- When power on polarity switching is set to On, a power on check is performed before a measurement screen appears. If the result of the power on check is NG, press “Yes” to return to the leakage current mode selection screen to check connections again.

Example : Selecting measurement mode (Enclosure-Enclosure leakage current) in the initial screen.
(network A)

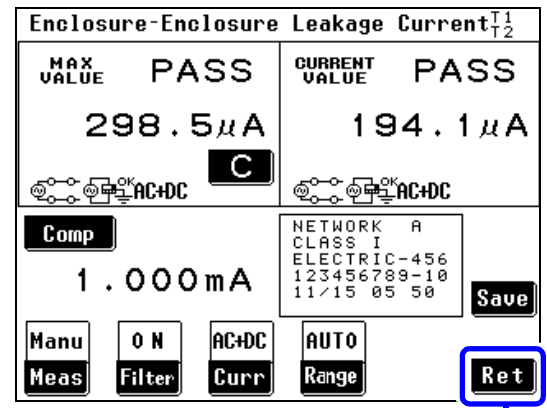
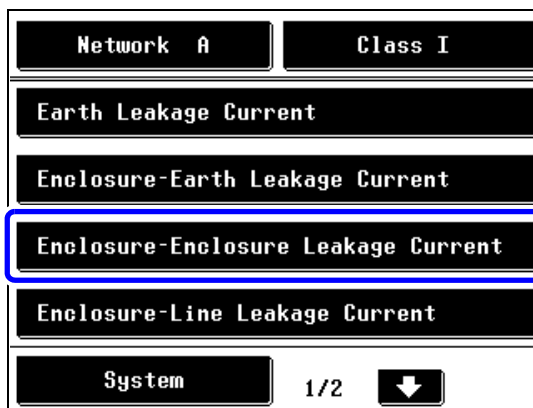

Return to initial screen.

4.3 Selecting a Measurement Mode (opens the measurement screen)

Selectable measurement modes

When selecting network A

Grounding class Measurement mode	Class-I equipment	Class-II equipment	Internally powered equipment
Earth leakage current	●	–	–
Enclosure - Earth leakage current	●	●	●
Enclosure - Enclosure leakage current	●	●	●
Enclosure - Line leakage current	●	●	–
Free current	●	●	●

● : Can be set, – : Cannot be set

When selecting network C or G

Grounding class Measurement mode	Class-I equipment	Class-II equipment	Internally powered equipment
Earth leakage current	●	–	–
Touch current (Enclosure - Earth)	●	●	●
Touch current (Enclosure - Enclosure)	●	●	●
Touch current (Enclosure - Line)	●	●	–

● : Can be set, – : Cannot be set

When selecting network D, E or F

Grounding class Measurement mode	Class-I equipment	Class-II equipment	Internally powered equipment
Earth leakage current	●	–	–
Enclosure - Earth leakage current	●	●	●
Enclosure - Enclosure leakage current	●	●	●
Enclosure - Line leakage current	●	●	–

● : Can be set, – : Cannot be set

4.3 Selecting a Measurement Mode (opens the measurement screen)

When selecting network B1

Grounding class \ Measurement mode applied part	Class-I equipment			Class-II equipment			Internally powered equipment		
	Type B	Type BF	Type CF	Type B	Type BF	Type CF	Type B	Type BF	Type CF
Earth leakage current	●	●	●	–	–	–	–	–	–
Enclosure - Earth leakage current	●	●	●	●	●	●	●	●	●
Enclosure - Enclosure leakage current	●	●	●	●	●	●	●	●	●
Patient auxiliary current	●	●	●	●	●	●	●	●	●
Patient leakage current I	●	●	●	●	●	●	●	●	●
Patient leakage current II	●	–	–	●	–	–	●	–	–
Patient leakage current III	–	●	●	–	●	●	–	●	●
Free current	●	●	●	●	●	●	●	●	●

● : Can be set, – : Cannot be set

When selecting network B2

Grounding class \ Measurement mode applied part	Class-I equipment			Class-II equipment			Internally powered equipment		
	Type B	Type BF	Type CF	Type B	Type BF	Type CF	Type B	Type BF	Type CF
Earth leakage current	●	●	●	–	–	–	–	–	–
Touch current (Enclosure - Earth)	●	●	●	●	●	●	●	●	●
Touch current (Enclosure - Enclosure)	●	●	●	●	●	●	●	●	●
Patient auxiliary current	●	●	●	●	●	●	●	●	●
Patient leakage current (Patient connection - Earth)	●	●	●	●	●	●	●	●	●
Patient leakage current (external voltage on a SIP/SOP)	●	●	●	●	●	●	●	●	●
Patient leakage current (external voltage on a specific F-type applied part)	–	●	●	–	●	●	–	●	●
Patient leakage current (external voltage on metal accessible part not protectively earthed)	●	●	–	●	●	–	●	●	–
Total patient leakage current (Patient connection - Earth)	●	●	●	●	●	●	●	●	●
Total patient leakage current (external voltage on a SIP/SOP)	●	●	●	●	●	●	●	●	●
Total patient leakage current (external voltage on a specific F-type applied part)	–	●	●	–	●	●	–	●	●
Total patient leakage current (external voltage on metal accessible part not protectively earthed)	●	●	–	●	●	–	●	●	–
Free current	●	●	●	●	●	●	●	●	●

● : Can be set, – : Cannot be set

4.4 Setting the Measurement Range (Auto/Hold)

Select auto range for automatic range selection. Selecting hold range allows the user to specify one of four ranges.

When using the Hold range, if you cannot have the faintest idea about the current type and size, please measure it by "AC+DC" to have a rough idea and decide the measurement range.

CAUTION

Note that the instrument may be damaged if the applied current exceeds the measurement range.

NOTE

- Any input that exceeds the indication range is indicated as "**OVER FLOW**".
 - The maximum indication value differs for network D,F and G.
(The range name indicated is the name of the representative network whose basic element is 1 k Ω .)
 - The minimum indication value in the Hold range setting varies depending on the network selected.
 - The range configuration differs only when the target current is set to "ACPeak."
- **Caution on using the Hold range**
When "!" is displayed and then a lower sensitivity range is chosen, the judgement result may be out of the guaranteed accuracy range.
- See** "About Peak Over !" (p. 58)
- As for ACPeak measurement, please set the allowable value to a bigger one than the minimum indication value in the range.
Setting a value less than the minimum indication value disables any numeric comparison, displayed "**Comp Low, Range Down**" and setting a value bigger than the maximum indication value, displayed "**Range Up**."
- See** Range of indication:
"Ammeter mode/unit of indication : AUTO range of indication" (p. 55)
- See** "Ammeter mode/unit of indication : mA (HOLD) range of indication" (p. 57)
- The auto range is not available when a 0.1 Hz frequency range setting is made. Selecting auto range automatically sets the hold range (during AC peak measurements: 1.000 mA range; during AC/DC/AC+DC measurements: 500.0 μ A range).

4.4 Setting the Measurement Range (Auto/Hold)

1. On the measurement screen, press **Range** to display the measurement range setting screen.

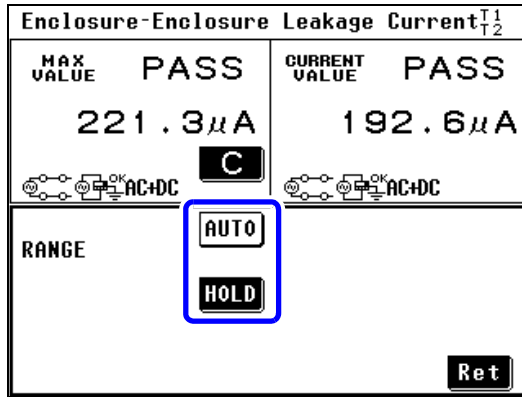

Select a measurement range.	
AUTO	Sets the current range to the Auto (automatic) range.
HOLD	Sets the current range to the Hold (fixed) range.

2. Selecting the Hold range displays a set of range setting keys. Use these keys to select a range.

When setting the target current to AC, DC, or AC+DC

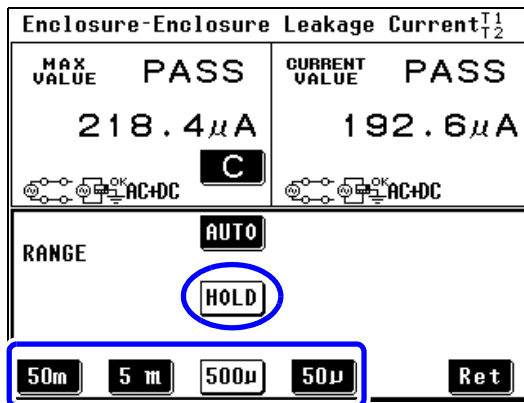

50m	Sets the fixed 50 mA range.
5 m	Sets the fixed 5 mA range.
500µ	Sets the fixed 500 µA range.
50µ	Sets the fixed 50 µA range.

The "fixed 500 µA range" is selected in this screen.

When setting the target current to AC Peak

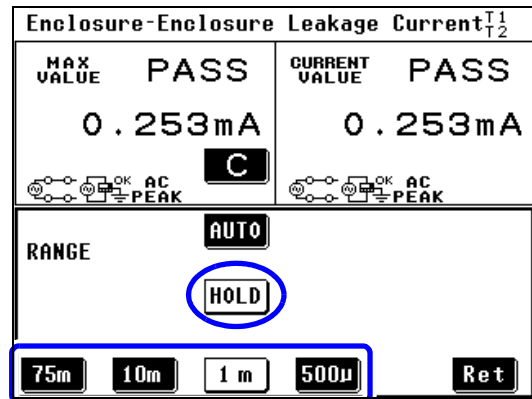

75m	Sets the fixed 75 mA range.
10m	Sets the fixed 10 mA range.
1 m	Sets the fixed 1 mA range.
500µ	Sets the fixed 500 µA range.

The "fixed 1 mA range" is selected in this screen.

3. Press **Ret** to return to the measurement screen.

4.4 Setting the Measurement Range (Auto/Hold)

Range of indication depends on selected unit of indication.

See "7.1 Setting the Mode (To use the instrument as a voltmeter)" (p. 117)

See For details of accuracy guaranteed range: "10.4 Accuracy" (p. 258)

See "7.10 Setting Indication Unit" (p. 131)

When selecting network A, B1, B2, C, E, or G

(Measurement of AC, DC, or AC+DC)

Range	50.00 mA	5.000 mA	500.0 μ A	50.00 μ A
Maximum indication value to Minimum indication value (In Hold range setting)	50.00 mA 0.00 mA (0.00 mA)	5.000 mA 0.000 mA (0.000 mA)	500.0 μ A 0.0 μ A (0.0 μ A)	50.00 μ A 1.01 μ A (0.00 μ A)

(Measurement of ACPeak)

Range	75.0 mA	10.00 mA	1.000 mA	500.0 μ A
Maximum indication value to Minimum indication value (In Hold range setting)	75.0 mA 0.0 mA (0.0 mA or less)	10.00 mA 0.00 mA (0.00 mA or less)	1.000 mA 0.000 mA (0.000 mA or less)	500.0 μ A 1.1 μ A (0.0 μ A)

When selecting network D

(Measurement of AC, DC, or AC+DC)

Range	50.00 mA	5.000 mA	500.0 μ A	50.00 μ A
Maximum indication value to Minimum indication value (In Hold range setting)	33.00 mA 0.00 mA (0.00 mA)	3.300 mA 0.000 mA (0.000 mA)	330.0 μ A 0.0 μ A (0.0 μ A)	33.00 μ A 1.01 μ A (0.00 μ A)

(Measurement of ACPeak)

Range	75.0 mA	10.00 mA	1.000 mA	500.0 μ A
Maximum indication value to Minimum indication value (In Hold range setting)	50.00 mA 0.0 mA (0.0 mA or less)	6.60 mA 0.00 mA (0.00 mA or less)	0.660 mA 0.000 mA (0.000 mA or less)	330.0 μ A 1.1 μ A (0.0 μ A)

When selecting network F

(Measurement of AC, DC, or AC+DC)

Range	50.00 mA	5.000 mA	500.0 μ A	50.00 μ A
Maximum indication value to Minimum indication value (In Hold range setting)	25.00 mA 0.00 mA (0.00 mA)	2.500 mA 0.000 mA (0.000 mA)	250.0 μ A 0.0 μ A (0.0 μ A)	25.00 μ A 1.01 μ A (0.0 μ A)

(Measurement of ACPeak)

Range	75.0 mA	10.00 mA	1.000 mA	500.0 μ A
Maximum indication value to Minimum indication value (In Hold range setting)	37.5 mA 0.0 mA (0.0 mA or less)	5.00 mA 0.00 mA (0.00 mA or less)	0.500 mA 0.000 mA (0.000 mA or less)	250.0 μ A 1.1 μ A (0.0 μ A)

4.4 Setting the Measurement Range (Auto/Hold)

Ammeter mode/unit of indication : mA (HOLD) range of indication

Sets the unit of current measurement to mA.

See "7.1 Setting the Mode (To use the instrument as a voltmeter)" (p. 117)

See For details of accuracy guaranteed range:"10.4 Accuracy" (p. 258)

See "7.10 Setting Indication Unit" (p. 131)

When selecting network A, B1, B2, C, E, or G

(Measurement of AC, DC, or AC+DC)

Range	50.00 mA	5.000 mA	500.0 μ A	50.00 μ A
Maximum indication value to Minimum indication value (In Hold range setting)	50.00 mA 0.00 mA (0.00 mA)	5.000 mA 0.000 mA (0.000 mA)	0.500 mA 0.000 mA (0.000 mA)	0.050 mA 0.002 mA (0.000 mA)

(Measurement of AC Peak)

Range	75.0 mA	10.00 mA	1.000 mA	500.0 μ A
Maximum indication value to Minimum indication value (In Hold range setting)	75.0 mA 0.0 mA (0.0 mA or less)	10.00 mA 0.00 mA (0.00 mA or less)	1.000 mA 0.000 mA (0.000 mA or less)	0.500 mA 0.002 mA (0.000 mA)

When selecting network D

(Measurement of AC, DC, or AC+DC)

Range	50.00 mA	5.000 mA	500.0 μ A	50.00 μ A
Maximum indication value to Minimum indication value (In Hold range setting)	33.00 mA 0.00 mA (0.00 mA)	3.300 mA 0.000 mA (0.000 mA)	0.330 mA 0.000 mA (0.000 mA)	0.033 mA 0.002 mA (0.002 mA)

(Measurement of AC Peak)

Range	75.0 mA	10.00 mA	1.000 mA	500.0 μ A
Maximum indication value to Minimum indication value (In Hold range setting)	50.0 mA 0.0 mA (0.0 mA or less)	6.60 mA 0.00 mA (0.00 mA or less)	0.660 mA 0.000 mA (0.000 mA or less)	0.330 mA 0.002 mA (0.000 mA)

When selecting network F

(Measurement of AC, DC, or AC+DC)

Range	50.00 mA	5.000 mA	500.0 μ A	50.00 μ A
Maximum indication value to Minimum indication value (In Hold range setting)	25.00 mA 0.00 mA (0.00 mA)	2.500 mA 0.000 mA (0.000 mA)	0.250 mA 0.000 mA (0.000 mA)	0.025 mA 0.002 mA (0.000 mA)

(Measurement of AC Peak)

Range	75.0 mA	10.00 mA	1.000 mA	500.0 μ A
Maximum indication value to Minimum indication value (In Hold range setting)	37.5 mA 0.0 mA (0.0 mA or less)	5.00 mA 0.00 mA (0.00 mA or less)	0.500 mA 0.000 mA (0.000 mA or less)	0.250 mA 0.002 mA (0.000 mA)

4.4 Setting the Measurement Range (Auto/Hold)

NOTE

About Peak Over "!"

- When measuring in Hold (fixed) range setting, if a portion of measuring current goes over the input allowable range for the circuit, "!" together with "FAIL" may be displayed on the measuring screen. "!" means that some of the instantaneous values go over the input allowable range. In this case, please select a lower sensitivity range to measure.
- When measuring in Auto (automatic) range, if some of the instantaneous values goes over the input allowable range and then a lower sensitivity range is chosen, the judgement result may be out of the guaranteed accuracy range.
- "!" will be displayed only in ammeter mode and not in voltmeter mode. "!" information is not available for RS-232C or GP-IB communication or printers. In case of displaying "!", "OVER FLOW" and "Range Up" will also be displayed.
- An error screen like the one shown in the figure appears when an excessive current input is made to the instrument. Check the equipment under test and the wiring and press the "Ret" key.

You must press the **Check** to start operation.

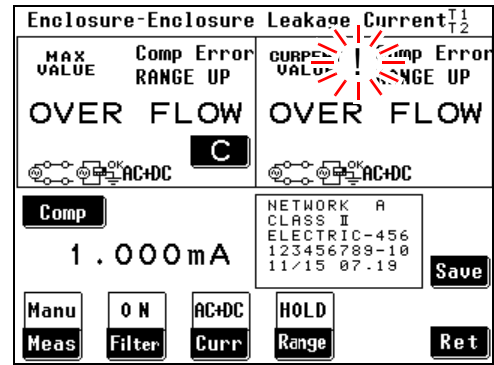

The input exceed the maximum input voltage or current. Check the input first, push the check key.

Check

4.5 Setting the Filter

(when selecting network A, B1, B2 or C)

Turn the filter for the measurement network ON and OFF or change the setting of the filter.
In manual measurement, the measurement value can be checked while switching the filter ON and OFF.

NOTE

When selecting network A, B1 or B2 :The filter is switched ON and OFF.
When selecting network C :The filter is set to ON1-U2/ON1 - U1/ON2-U3/ON2-U1 or OFF.
When selecting network D, E, F or G : No setting for filter.

When selecting network A

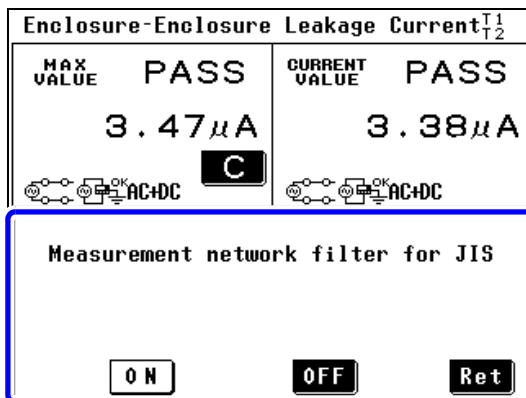

1. On the measurement screen, press **Filter** to display the network filter setting screen.
2. Change the setting of the filter for the network.

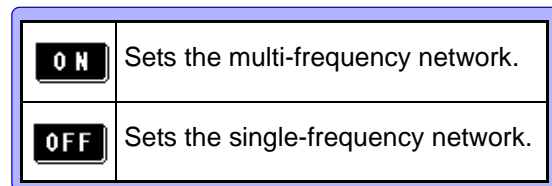

3. Press **Ret** to return to the measurement screen.

When selecting network B1, B2

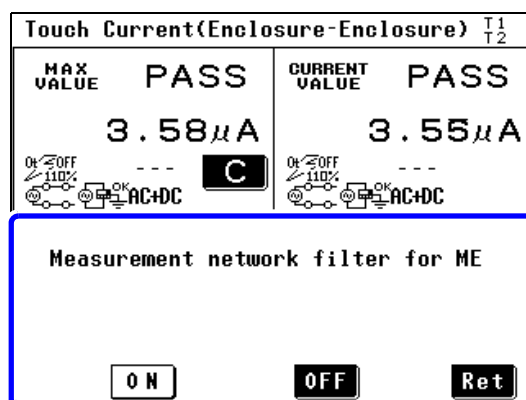

1. On the measurement screen, press **Filter** to display the network filter setting screen.
2. Change the setting of the filter for the network.

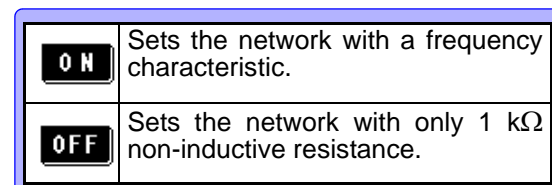

3. Press **Ret** to return to the measurement screen.

4.5 Setting the Filter

When selecting network C

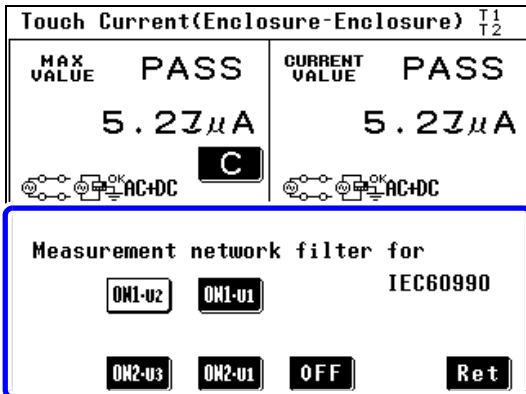

1. On the measurement screen, press **Filter** to display the network filter setting screen.
2. Change the setting of the filter for the network.

ON1-U1	Sets a network compatible with perception/reaction.
ON1-U2	
ON2-U1	Sets a network compatible with abandonment.
ON2-U3	
OFF	Sets the body impedance network.

See "Network C (for IEC 60990)" (p. 272)

3. Press **Ret** to return to the measurement screen.

4.6 Setting the Allowable Value

Set the allowable value (upper-limit leakage current value) for the measurement value and maximum value.

According to the status (normal condition, single-fault condition) of the equipment under test, two values can be set.

The allowable value setting is based on "Numeric value x Factor."

Use the allowable value setting to provide a margin or compensate for measurement error.

The factor is set to "100%" by default. (Input range 1 to 100%)

Set a lower limit value when required.

- Setting a lower limit value for all measurement modes.

See "7.9 Setting Lower Limit Values (factor)" (p. 130)

- Setting a lower limit value for specific measurement modes.

See "Turning lower limit values on and off for specific leakage current measurements" (p. 63)

The instrument indicates the result (PASS/FAIL/LOW indication) of comparison between the measurement value and allowable value.

In automatic measurement, the judgement result is output from EXT I/O.

See "9.2 Connecting to the EXT I/O Terminal" (p. 247)

The buzzer that sounds based on the judgement result can be disabled.

See "7.13 Setting the Beep Sound" (p. 135)

4.6 Setting the Allowable Value

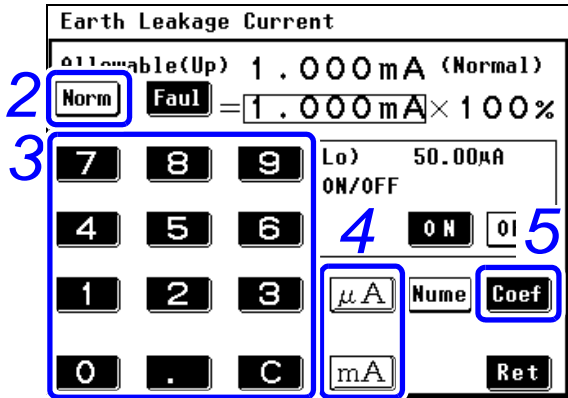

Allowable value setting screen
(Normal condition, numeric value setting mode)

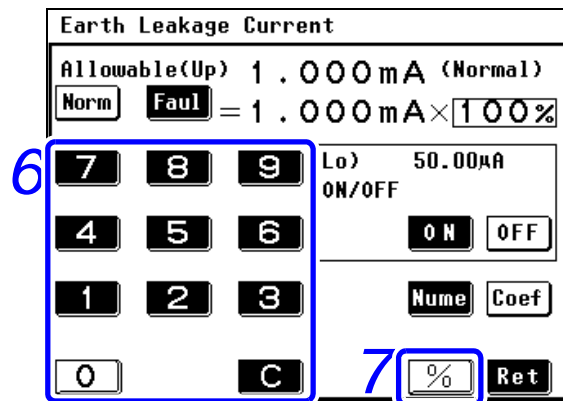

Allowable value setting screen
(Normal condition, factor setting mode)

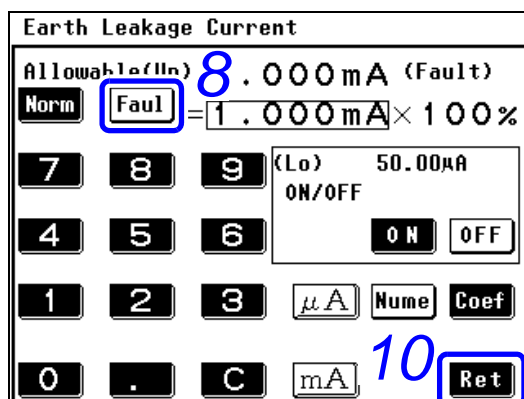

Allowable value setting screen
(fault condition, numeric value setting mode)

1. On the measurement screen, press **Comp** to display the allowable value setting screen.
2. Press **Norm** to activate the allowable value setting condition for normal condition.
3. Enter a numeric value by using numeric keys (**0** through **9**, and **.**).
- To correct an input error, press the Clear (**C**) key, then reenter the input.
4. Enter the unit of allowable value.
Pressing a Unit key (**µA**, **mA**) immediately confirms the numeric input.
5. Press **Coef** to set factor setup status for set allowable value.
6. Enter a numeric value by using numeric keys (**0** through **9**).
- To correct an input error, press the Clear (**C**) key, then reenter the input.
7. Pressing the Unit key (**%**) immediately confirms the factor input.
8. Press **Faul** to activate the allowable value setting condition for fault condition.
9. In the same way as for setting the normal condition, make the necessary settings by following steps 3 through 7.
10. Press **Ret** to return to the measurement screen.

NOTE

- The allowable value setting range is from 5 μA to 50 mA.
If a value less than 5 μA is entered, the setting is automatically adjusted to "5 μA ."
If a value greater than 50 mA is entered, the setting is automatically adjusted to "50 mA."
- If the screen is changed without pressing μA , mA or %, the new allowable value setting does not take effect.
- The Unit keys (μA , mA, %) cannot be operated until a numeric key is pressed.

About allowable value judgement

When the indication unit is fixed to "mA," FAIL judgement may result even if the measurement value (or maximum value) and allowable value are the same. This is because internally retained data contains lower-order digits even if the unit is fixed to "mA," and judgement is made using the values with lower-order digits.

An allowable value setting lower than the accuracy guarantee range, displayed "Comp Low".

Turning lower limit values on and off for specific leakage current measurements

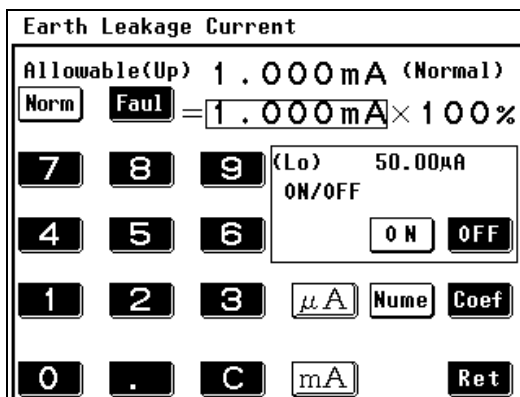

Use the functions below to turn the lower limit value on or off for specific measurements.

Press **ON** to turn the lower limit value on.

Press **OFF** to turn the lower limit value off.

NOTE

This screen allows you only to turn lower limit values On or Off. Use the System settings (p. 130) to change coefficients for lower limit values or turn on or off all lower limit values.

4.7 Selecting the Type of Target Current

1. On the measurement screen, press **Curr** to display the target current setting screen.

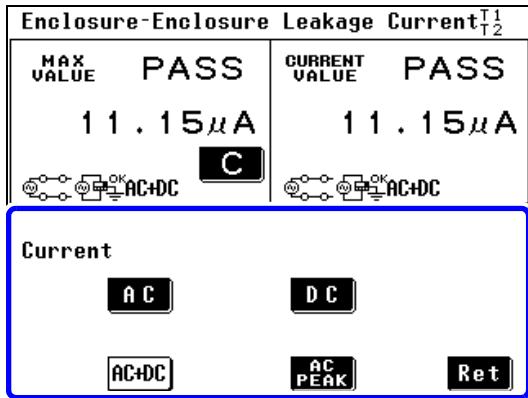

Auxiliary current setting screen

Select the type of target current.

AC	For AC measurement
DC	For DC measurement
AC+DC	For AC + DC measurement
AC PEAK	For AC peak measurement

2. Press **Ret** to return to the measurement screen.

Measurement screen

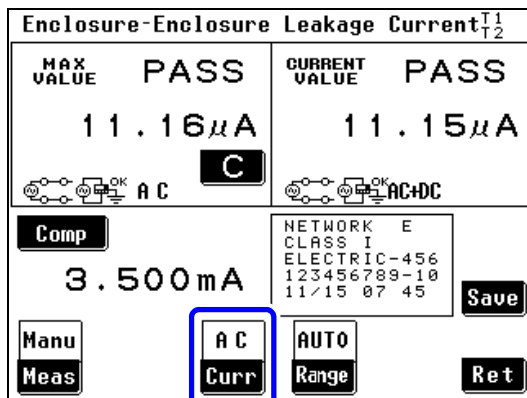

In the diagram, the target current is set to "AC" (alternating current).

Measurement screen
(When selecting network B1 or B2)

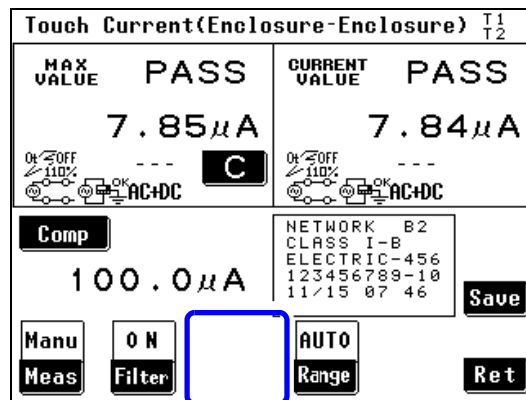

When network B1 or B2 is selected, some measurement modes do not permit measurement current settings and can therefore not indicate current and current setting conditions. Only measurement modes involving multiple auxiliary currents are displayed to enable selection of auxiliary current.
See "Selectable target currents" (p. 65)

NOTE

Curr appears on the measurement screen only when selection of auxiliary current is enabled.

4.7 Selecting the Type of Target Current

Selectable target currents

Network / Measurement mode	A	D	E	F
Earth leakage current	AC DC AC+DC x	AC DC AC+DC ACPeak	AC DC AC+DC ACPeak	AC DC AC+DC ACPeak
Enclosure - Line leakage current	AC DC AC+DC x	AC DC AC+DC ACPeak	AC DC AC+DC ACPeak	AC DC AC+DC ACPeak
Enclosure - Earth leakage current	AC DC AC+DC x	AC DC AC+DC ACPeak	AC DC AC+DC ACPeak	AC DC AC+DC ACPeak
Enclosure - Enclosure leakage current	AC DC AC+DC x	AC DC AC+DC ACPeak	AC DC AC+DC ACPeak	AC DC AC+DC ACPeak
Free current	AC DC AC+DC ACPeak	-	-	-

x: Cannot be set -: Not applicable

Network / Measurement mode	B1	B2	C	G
Earth leakage current	x x AC+DC x	x x AC+DC x	AC DC AC+DC ACPeak	AC DC AC+DC ACPeak
Touch current (Enclosure - Line)	-	-	AC DC AC+DC ACPeak	AC DC AC+DC ACPeak
Touch current (Enclosure - Earth)	x x AC+DC x	x x AC+DC x	AC DC AC+DC ACPeak	AC DC AC+DC ACPeak
Touch current (Enclosure - Enclosure)	x x AC+DC x	x x AC+DC x	AC DC AC+DC ACPeak	AC DC AC+DC ACPeak
Patient auxiliary current	AC DC x x	AC DC x x	-	-
Patient leakage current (Patient connection - Earth) * B1:Patient leakage current I	AC DC x x	AC DC x x	-	-
Patient leakage current (external voltage on a SIP/SOP) * B1:Patient leakage current II	x x AC+DC x	AC DC x x	-	-
Patient leakage current (external voltage on a specific F-type applied part) * B1:Patient leakage current III	x x AC+DC x	x x AC+DC x	-	-

x: Cannot be set -: Not applicable

4.7 Selecting the Type of Target Current

Measurement mode \ Network	B1	B2	C	G
Patient leakage current (external voltage on metal accessible part not protectively earthed)	–	x x AC+DC x	–	–
Total patient leakage current (Patient connection - Earth)	–	AC DC x x	–	–
Total patient leakage current (external voltage on a SIP/SOP)	–	AC DC x x	–	–
Total patient leakage current (external voltage on a specific F-type applied part)	–	x x AC+DC x	–	–
Total patient leakage current (external voltage on metal accessible part not protectively earthed)	–	x x AC+DC x	–	–
Free current	AC DC AC+DC ACPeak	AC DC AC+DC ACPeak	–	–

x: Cannot be set –: Not applicable

4.8 Changing the Measurement Method (Auto/Manual)

(1) Manual measurement

The measurement value can be checked while changing the target current, filter setting, power supply polarity, and equipment status.

(2) Automatic measurement

The power supply polarity and equipment status are automatically switched during measurement.

The item to be switched automatically can be selected and the measuring time set.

1. On the measurement screen, press **Meas** to display the manual/auto measurement setting screen.

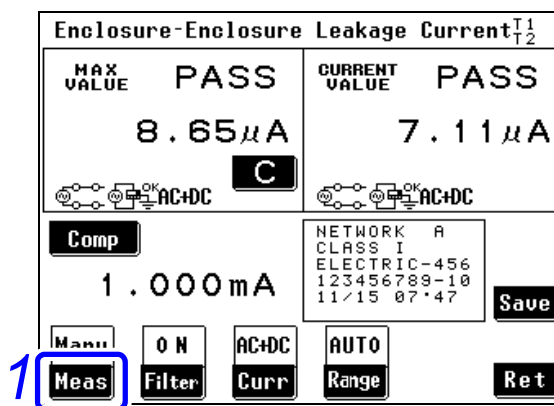

2. Select a measurement mode.

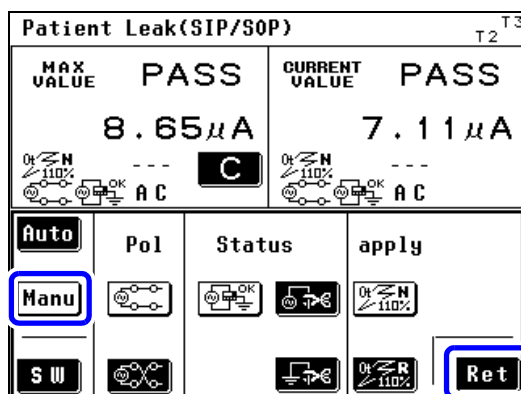
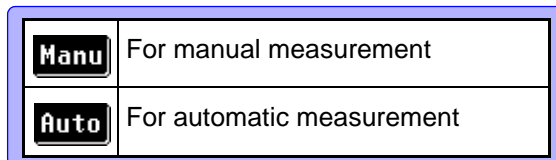

Setting screen
(Manual measurement)

Return to
measurement
screen.

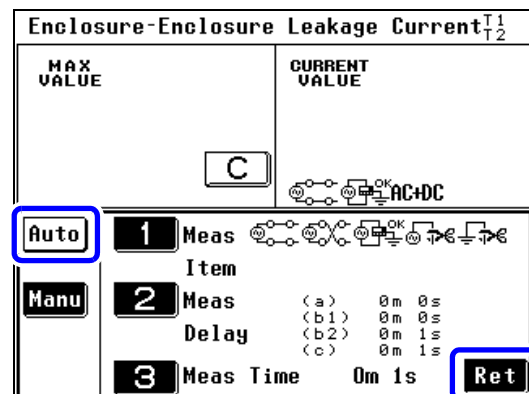

Setting screen
(Automatic measurement)

Return to
measurement
screen.

Measurements start when measurement is set to "Manual" in the measurement screen. Measurement conditions can be changed during ongoing measurements. Continue to "Chapter 5 Measurement Preparations" (p. 75).

Make the following settings to make automatic measurements.

4.8 Changing the Measurement Method (Auto/Manual)

Setting automatic measurement items

The selected network, class and measurement mode determine what measurement items will appear. See Appendix2 "List of instrument status, other test condition and special test condition"(p.A4)

1. On the automatic measurement setting screen, press **1** to display the automatic measurement item setting screen.
2. Turn automatic measurement for each measurement item ON or OFF. Each time a key is pressed, the indication switches between ON and OFF.

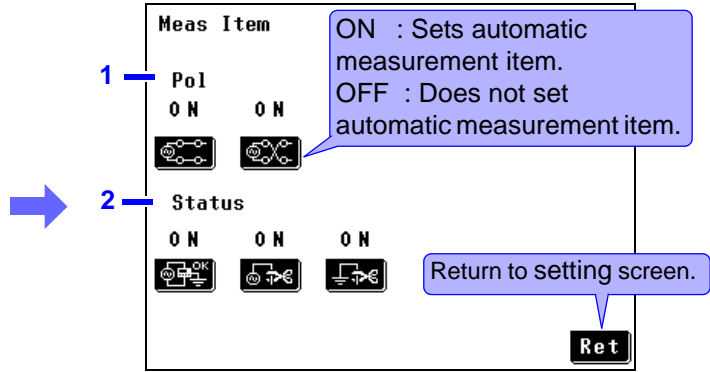
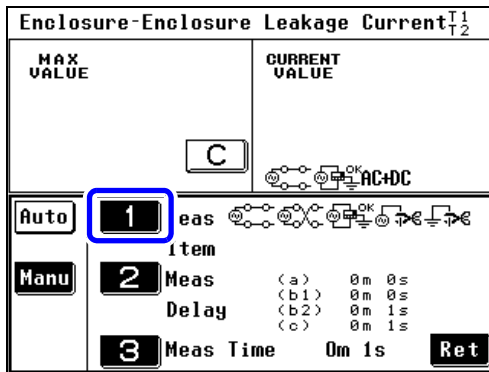

Automatic measurement item setting screen

1. Power supply polarity

	Indicates "positive phase."
	Indicates "negative phase."

Equipment with an internal power supply cannot be set.
See "Line phase in leakage current measurement between enclosure and line" (p. 69)

2. Condition of equipment under test (power supply)

	Sets "Normal condition."
	Sets a "Single fault condition" (power supply lead is disconnected).
	Sets a "Single fault condition"(protective earth terminal is disconnected).

Other conditions

	Applies a voltage to the L line.
	Applies a voltage to the N line.
	Sets application of 110% of voltage, positive phase. (When selecting network B1.)
	Sets application of 110% of voltage, negative phase. (When selecting network B1.)

Other test condition (Other applied voltages)*2

	*1 Sets application of 110% of voltage, positive phase.
	*1 Sets application of 110% of voltage, negative phase.
	Sets application of 110% of voltage, OFF.

See "Measurement with 110% voltage application (Other test condition)" (p. 69)

Special test condition (Specific applied voltage)*2

	*1 Sets application of 110% of voltage, positive phase.
	*1 Sets application of 110% of voltage, negative phase.

See "Measurement with 110% voltage application (Special test condition)" (p. 69)

Target current

Measurement current can be selected when automatic measurement item is selected only when network B1 or B2 is selected and patient leakage current I mode, patient leakage current (Patient connection - Earth) or patient auxiliary current is also selected. (In any other mode, AC + DC is automatically selected and cannot be changed)

	Sets AC measurement.
	Sets DC measurement.

*1 The "N" key indicates positive phase and "R" negative phase.

*2 When selecting network B2

4.8 Changing the Measurement Method (Auto/Manual)

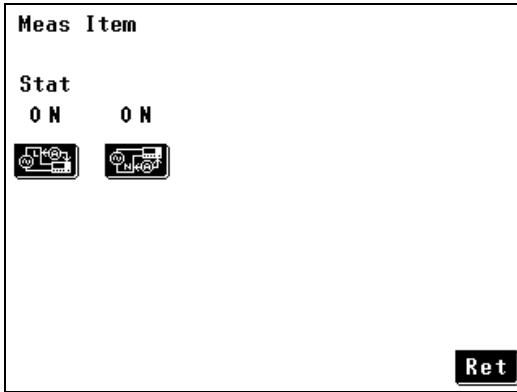

EX.: Automatic measurement item setting measurement between enclosure and line

Line phase in leakage current measurement between enclosure and line

Shown when network A, C, D, E, F or G is selected.

	Conducts measurement with voltage of the L (live) side of power supplied to [LINE IN].
	Conducts measurement with voltage of the N (neutral) side of power supplied to [LINE IN].

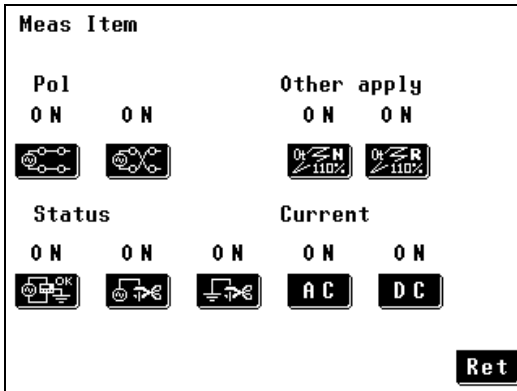

EX.: Automatic measurement item setting screen for network B2 and patient leakage current (SIP/SOP) measurement

Measurement with 110% voltage application (Other test condition)

Shown when network B2 is selected

	* Conducts measurement with voltage that is in the same phase as power supplied to [LINE IN].
	* Conducts measurement with voltage that is in the reversed phase of power supplied to [LINE IN].
	* Conducts measurement turning off power supply connected to [LINE IN].

These two settings cannot be set to OFF at the same time.

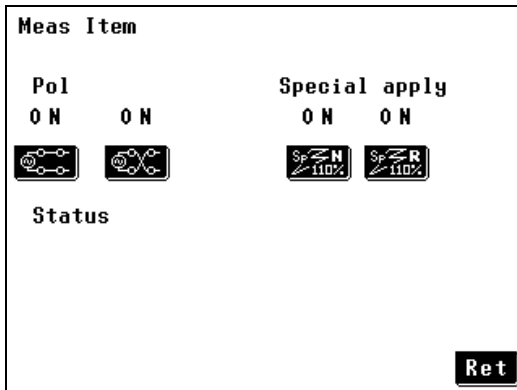

EX.: Automatic measurement item setting screen for network B2 and patient leakage current (Metal accessible part) measurement

Measurement with 110% voltage application (Special test condition)

Shown when network B2 is selected

	* Conducts measurement with voltage that is in the same phase as power supplied to [LINE IN].
	* Conducts measurement with voltage that is in the reversed phase of power supplied to [LINE IN].

These two settings cannot be set to OFF at the same time.

*The "N" key indicates positive phase and "R" negative phase.

NOTE

All measurement items cannot be turned off.
At least one item must be on.
(An attempt to turn off all items, will cause one item to go on.)

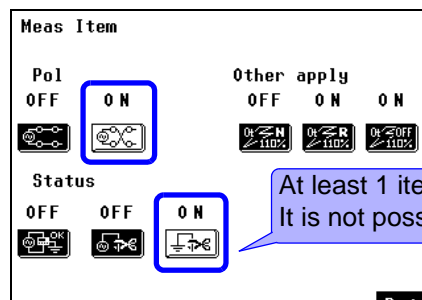

At least 1 item will be on.
It is not possible to turn off all items.

4.8 Changing the Measurement Method (Auto/Manual)

Setting the measurement delay (delay time)

On the automatic measurement screen, press **2** to display the measurement delay time setting screen.

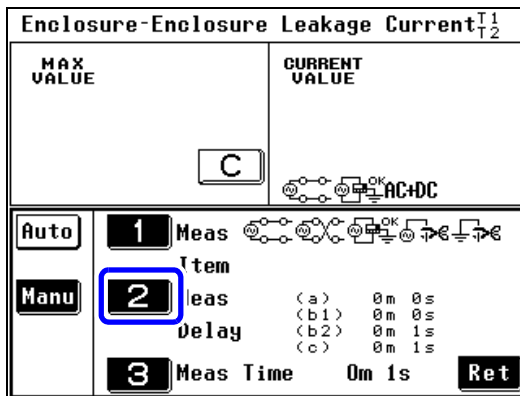

Automatic measurement item setting screen

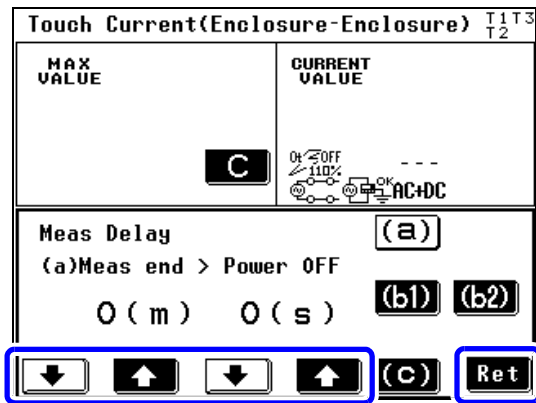

Measurement delay time setting screen

- Increments the numeric value.
- Decrements the numeric value.

Return to Automatic measurement item setting screen

Delay times

The figure below shows the relationship between delay times (a), (b1), (b2) and (c) and measurement time.

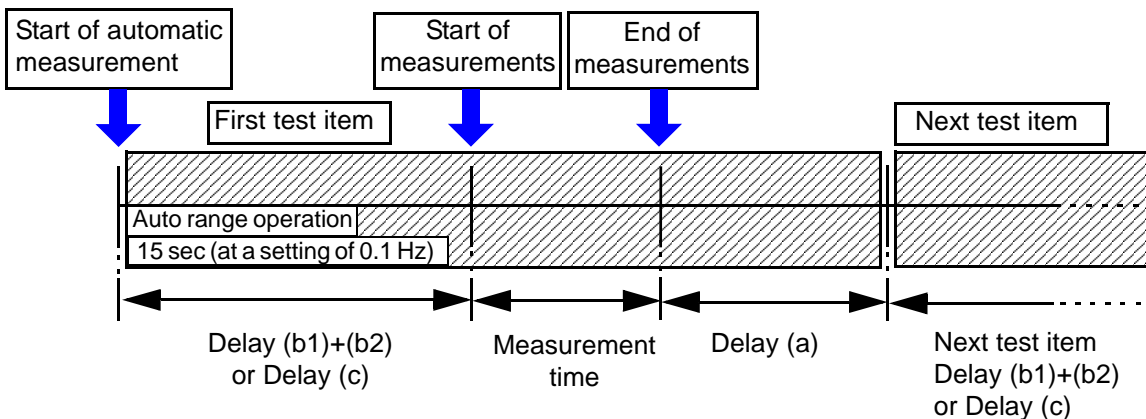

NOTE

In the following cases, delay b2 and delay c may last longer than the set delay time.

- When auto range is set and auto range does not stabilize during the set delay time, the delay time is extended as required.
- The time-out for auto range is 5 seconds. If the range does not stabilize within 5 seconds, operation is terminated.
- When the frequency range is set to start from 0.1 Hz, 15 sec is added before measurements start so a measurement setting of less than 15 sec will still include a 15 sec delay. (Includes a 15 sec delay time)

However, if the delay time is set to 15 sec or longer, that setting will have priority.

4.8 Changing the Measurement Method (Auto/Manual)

(a): Setting the time for disconnecting one wire

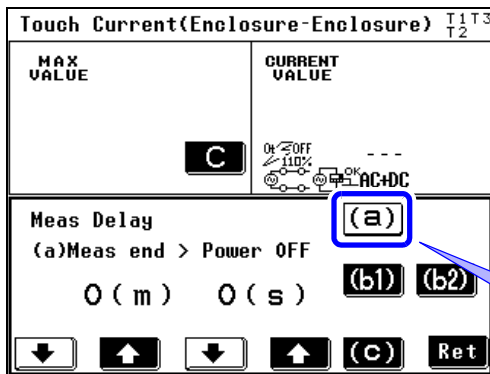

Use this function to set the time of disconnection of one wire after the previous measurement ends and before continuing with the next one when the next measurement is "disconnection of one wire in power cord."
 (This time setting gives a connected computer enough time to shut down before "disconnection of one wire in power cord" occurs as a sudden shutdown could damage it.)

Press **(a)** and set Delay (a).
 (0 sec. to 30 min. (in 1 sec. increments))

(b1), (b2): Setting polarity switching time

NOTE

When power on polarity switching is used, the power is not turned off even during polarity switching and a delay (b1 and b2) need not be set.

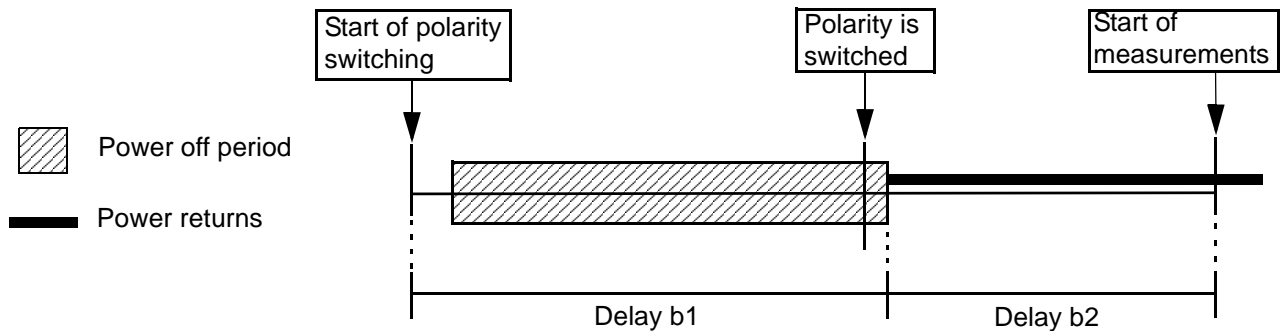

Delay b1

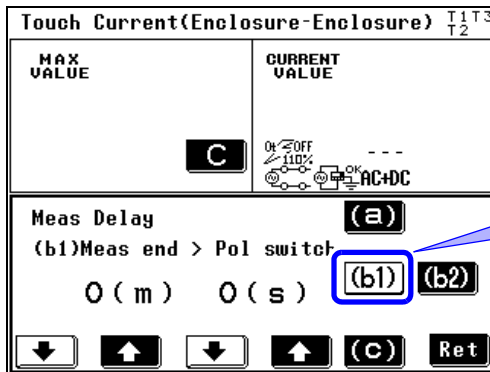

The power is momentarily turned off when polarity is switched. Set this delay to prevent damaging equipment by power being turned off and then immediately being turned back on.

Press **(b1)** and set Delay (b2).
 (0 sec. to 30 min. (in 1 sec. increments))

Delay b2

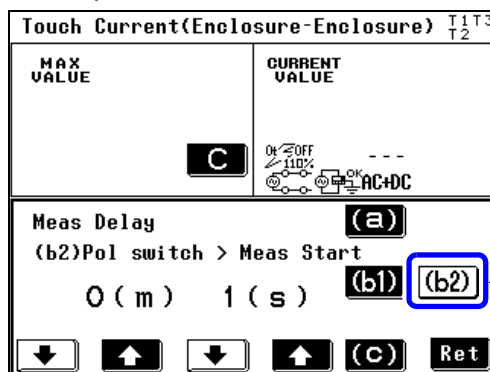

The power is momentarily turned off when polarity is switched. Set this delay in turning the power on again after equipment under test has been turned off.

Press **(b2)** and set Delay (b2).
 (1 sec. to 30 min. (in 1 sec. increments))

4.8 Changing the Measurement Method (Auto/Manual)

(c): Setting the time to start measurements not involving polarity switching

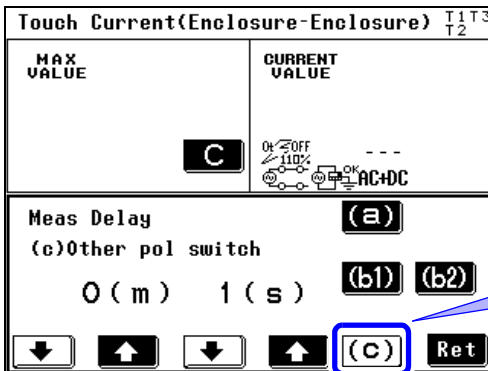

Use this function to set the time for the start of the next measurement under conditions other than (a) and (b). Set a delay for measurements that does not involve polarity switching.

Press **(C)** and set Delay (c).
(1 sec. to 30 min. (in 1 sec. increments))

Setting the measuring time

1. On the automatic measurement screen, press **3** to display the measurement time setting screen.
2. Set the measuring time. (1 sec. to 5 min. (in 1 sec. increments))

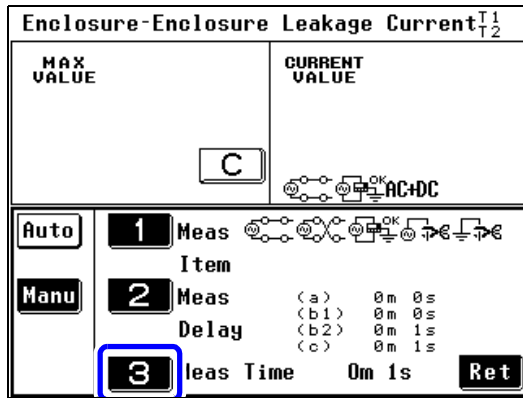

Automatic measurement item setting screen

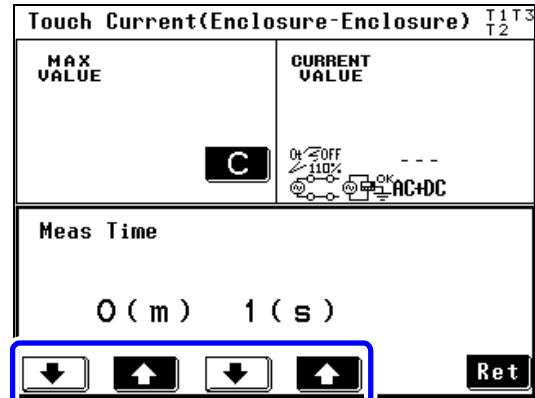

Measuring time setting screen

- ↑ Increments the numeric value.
- ↓ Decrements the numeric value.

NOTE

If measurement values do not stabilize due to abrupt input fluctuations in the auto range during automatic measurements, measurements are terminated and no further measurements are made.

Status indication of instrument during automatic measurements

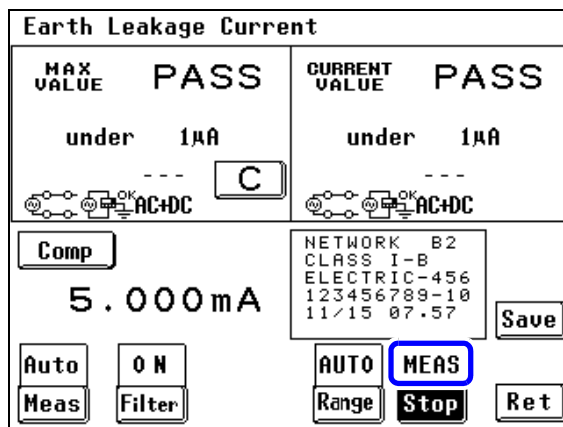

During automatic measurements, the item above the Stop key indicates instrument status.

Displayed items	
(a)	Time until transition to disconnection of one wire in power cord
(b1)	Time until power supply polarity is switched
(b2)	
(c)	Time until transition to measurements other than polarity switching
MEAS	During measurements

Measurement Preparations

Chapter 5

5.1 Connecting the Test Lead



When a measurement mode is selected, the measuring terminals (T1, T2, and T3) to be used for measurement are indicated at the top of the screen.

Connect the test leads based on the indications displayed.

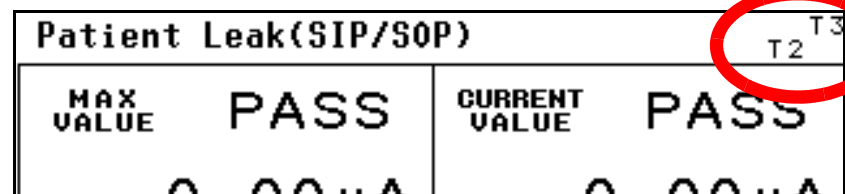

To avoid breaking the test leads, do not bend or pull them.

The list of the measuring terminals to be used

When selecting network A, D, E or F

	Class-I equipment	Class-II equipment	Internally powered equipment
Earth leakage current	–	–	–
Enclosure - Earth leakage current	T2	T2	T2
Enclosure - Enclosure leakage current	T1, T2	T1, T2	T1, T2
Enclosure - Line leakage current (Selected line Internal)	T2	T2	–
Enclosure - Line leakage current (Selected line External)	T1, T2	T1, T2	–
Free current *	T1, T2	T1, T2	T1, T2

*Only network A provides free current

When selecting network C, G

	Class-I equipment	Class-II equipment	Internally powered equipment
Earth leakage current	–	–	–
Touch current (Enclosure - Earth)	T2	T2	T2
Touch current (Enclosure - Enclosure)	T1, T2	T1, T2	T1, T2
Touch current (Enclosure - Line) (Selected line Internal)	T2	T2	–
Touch current (Enclosure - Line) (Selected line External)	T1, T2	T1, T2	–

5.1 Connecting the Test Lead

When selecting network B1

		Class-I equipment			Class-II equipment			Internally powered equipment		
		Type B	Type BF	Type CF	Type B	Type BF	Type CF	Type B	Type BF	Type CF
Earth leakage current		–			–			–		
Enclosure - Earth leakage current	Normal	T2	T2	T2	T2	T2	T2	T2	T2	T2
	Fault/Apply	T2,T3	T2,T3	T2,T3	T2,T3	T2,T3	T2,T3	T2,T3	T2,T3	T2,T3
Enclosure - Enclosure leakage current	Normal	T1,T2	T1,T2	T1,T2	T1,T2	T1,T2	T1,T2	T1,T2	T1,T2	T1,T2
	Fault/Apply	T1,T2,T3	T1,T2,T3	T1,T2,T3	T1,T2,T3	T1,T2,T3	T1,T2,T3	T1,T2,T3	T1,T2,T3	T1,T2,T3
Patient auxiliary current		T1,T2	T1,T2	T1,T2	T1,T2	T1,T2	T1,T2	T1,T2	T1,T2	T1,T2
Patient leakage current I		T2	T2	T2	T2	T2	T2	T1,T2	T1,T2	T1,T2
Patient leakage current II		T2,T3	–	–	T2,T3	–	–	T2,T3	–	–
Patient leakage current III		–	T2	T2	–	T2	T2	–	T2	T2
Free current	Normal	T1,T2	T1,T2	T1,T2	T1,T2	T1,T2	T1,T2	T1,T2	T1,T2	T1,T2
	Fault/Apply	T1,T2,T3	T1,T2,T3	T1,T2,T3	T1,T2,T3	T1,T2,T3	T1,T2,T3	T1,T2,T3	T1,T2,T3	T1,T2,T3

When selecting network B2

		Class-I equipment			Class-II equipment			Internally powered equipment		
		Type B	Type BF	Type CF	Type B	Type BF	Type CF	Type B	Type BF	Type CF
Earth leakage current		–			–			–		
Touch current (Enclosure - Earth)	Normal	T2	T2	T2	T2	T2	T2	T2	T2	T2
	Fault/Apply	T2,T3	T2,T3	T2,T3	T2,T3	T2,T3	T2,T3	T2,T3	T2,T3	T2,T3
Touch current (Enclosure - Enclosure)	Normal	T1,T2	T1,T2	T1,T2	T1,T2	T1,T2	T1,T2	T1,T2	T1,T2	T1,T2
	Fault/Apply	T1,T2,T3	T1,T2,T3	T1,T2,T3	T1,T2,T3	T1,T2,T3	T1,T2,T3	T1,T2,T3	T1,T2,T3	T1,T2,T3
Patient auxiliary current		T1,T2	T1,T2	T1,T2	T1,T2	T1,T2	T1,T2	T1,T2	T1,T2	T1,T2
Patient leakage current (Patient connection - Earth)		T2	T2	T2	T2	T2	T2	T1,T2 or T2	T1,T2 or T2	T1,T2 or T2
Patient leakage current (external voltage on a SIP/SOP)		T2,T3	T2,T3	T2,T3	T2,T3	T2,T3	T2,T3	T2,T3	T2,T3	T2,T3
Patient leakage current (external voltage on a specific F-type applied part)		–	T2	T2	–	T2	T2	–	T2	T2
Patient leakage current (external voltage on metal accessible part not protectively earthed)		T2,T3	T2,T3	–	T2,T3	T2,T3	–	T2,T3	T2,T3	–
Total patient leakage current (Patient connection - Earth)		T2	T2	T2	T2	T2	T2	T1,T2	T1,T2	T1,T2
Total patient leakage current (external voltage on a SIP/SOP)		T2,T3	T2,T3	T2,T3	T2,T3	T2,T3	T2,T3	T2,T3	T2,T3	T2,T3
Total patient leakage current (external voltage on a specific F-type applied part)		–	T2	T2	–	T2	T2	–	T2	T2
Total patient leakage current (external voltage on metal accessible part not protectively earthed)		T2,T3	T2,T3	–	T2,T3	T2,T3	–	T2,T3	T2,T3	–
Free current	Normal	T1,T2	T1,T2	T1,T2	T1,T2	T1,T2	T1,T2	T1,T2	T1,T2	T1,T2
	Fault/Apply	T1,T2,T3	T1,T2,T3	T1,T2,T3	T1,T2,T3	T1,T2,T3	T1,T2,T3	T1,T2,T3	T1,T2,T3	T1,T2,T3

Using L2200 Test Lead



!WARNING

To avoid the risk of electric shock, do not touch the tips of test leads connected to terminals T1, T2, and T3.

In some measurement modes, high voltage is output from the terminals.

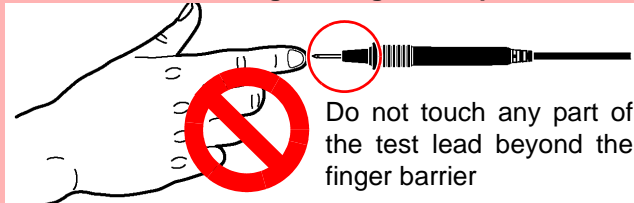

Do not touch any part of the test lead beyond the finger barrier

Connect the L2200 Test Lead to a measuring terminal (T1, T2, or T3).
The terminal to be used varies depending on the measurement mode.
See "5.1 Connecting the Test Lead" (p. 75)

NOTE

To apply 110% of rated voltage, use an isolation transformer to supply the voltage to [LINE IN].

The voltage applied to [LINE IN] is also output from the T3 terminal.

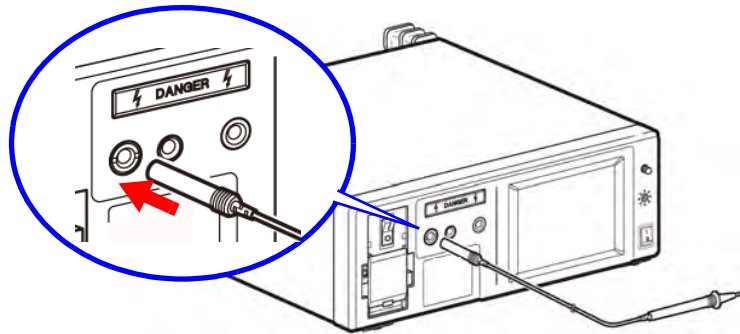

Using the 9195 Enclosure Probe (for measuring enclosure leakage current)

When measuring enclosure leakage current, position the surface contact probe on the enclosure of the equipment under test, then set the test lead on the surface contact probe.

Ensure full contact of the surface contact probe on the enclosure by applying about 0.5 N/cm² of pressure.

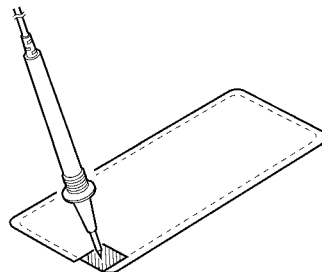

5.1 Connecting the Test Lead

Using Alligator Clips (when using two or three test leads)

Position the test lead on the enclosure or terminal of the equipment under test to measure leakage current. When using two or three lead wires, alligator clips may be used to ensure a secure connection. Detach the pin lead from the tip of each L2200 Test Lead and insert the included alligator clip.

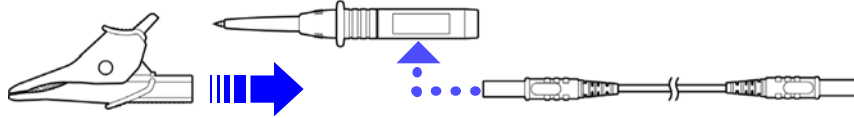

NOTE

Pin leads and alligator clips can be connected to either end of the connection cord.

Measurements

Chapter 6

6.1 Making manual measurements

Free-run measurements start when measurement is set to "Manual" in the measurement screen. Measurement conditions can be changed during ongoing measurements. (Manual measurements cannot be made when an internal class is selected.)

Pre-test inspection

Perform a pre-test inspection.
See "3.5 Pre-Test Inspection" (p. 41)

Setup

Set up the instrument.
See "Chapter 4 Settings" (p. 47)

During measurements (switching manual measurement item)

On the measurement screen, press **Meas** and then **Manu** to display the manual measurement setting screen. This allows the user to change power supply polarity and equipment condition.

The measurement items that appear depend on the selected network, class and measurement mode.
See "Changing manual measurement items" (p. 80)

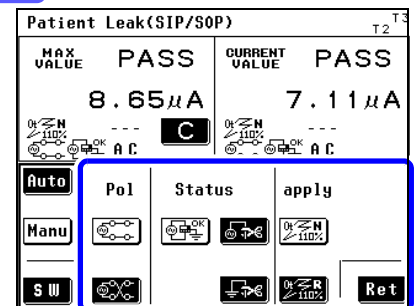

During measurements (switching auxiliary current)

On the measurement screen, press **Curr** to display the target current setting screen. This setting allows the user to change the target current.
See "Changing manual measurement items" (p. 80)

The CAL key appears when 0.1 Hz frequency range is set.
See (p. 43)

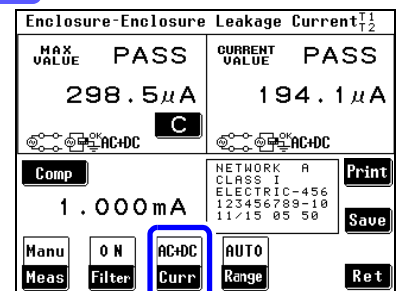

When measurements end

When measurements end, print or save the measurements as required. On the measurement screen,

press **Print** to print the measurement data.
See "6.6 Printing Measurement Data (as required)" (p. 108)

On the measurement screen,

press **Save** to store the measurement data in internal memory.
See "6.4 Saving Measurement Data (As required)" (p. 102)

To repeat automatic measurements, press **Ret**.

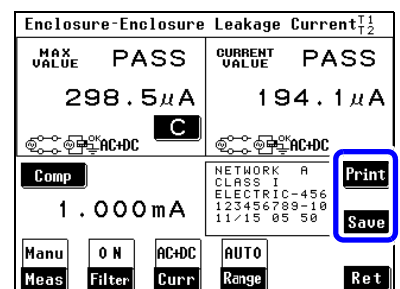



6.1 Making manual measurements

Changing manual measurement items

The indication varies depending on the network, class setting, and measurement mode selected.

See Appendix2 "List of instrument status, other test condition and special test condition" (p. A4)



1. Power supply polarity

	Indicates "positive phase."
	Indicates "negative phase."





Equipment with an internal power supply cannot be set.

2. State of equipment under test (power supply)

No equipment whose grounding class is internal can be set.



	Sets "Normal condition."
	Sets a "Single fault condition" (power supply lead is disconnected).
	Sets a "Single fault condition" (protective earth terminal is disconnected).

Other conditions

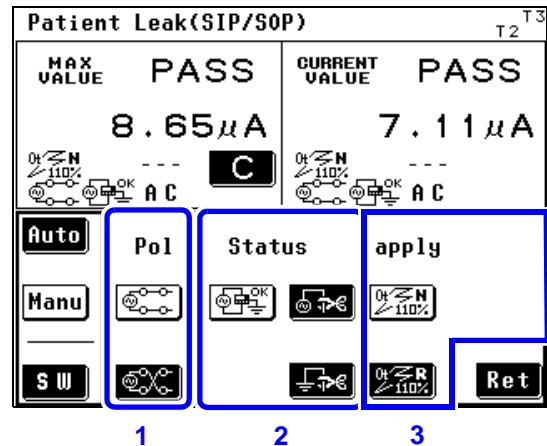

	Sets application of 110% of voltage, positive phase.
	Sets application of 110% of voltage, negative phase.
	Sets application of 110% of voltage, positive phase. (When selecting network B1.)
	Sets application of 110% of voltage, negative phase. (When selecting network B1.)



3. Other test condition (Other applied voltages) (When selecting network B2.)

	* Sets application of 110% of voltage, positive phase.
	* Sets application of 110% of voltage, negative phase.
	Sets application of 110% of voltage, OFF.

Special test condition (Specific applied voltage)

	* Sets application of 110% of voltage, positive phase.
	* Sets application of 110% of voltage, negative phase.

*The "N" key indicates positive phase and "R" negative phase.

SW status (only network B2 on ST5540)

Pressing **SW** in the manual measurement setting screen opens the switch setting screen.

S10	SW for connecting functional earth terminal and power supply system for measurement. Set to On to connect to the LINE IN E terminal.
S12	SW for connecting patient connection to ground of power supply circuit for measurement. Set to On to connect to the LINE IN E terminal.
S13	Terminal providing ground connection for metal accessible part not protectively earthed. Set to On to connect to the LINE IN E terminal.

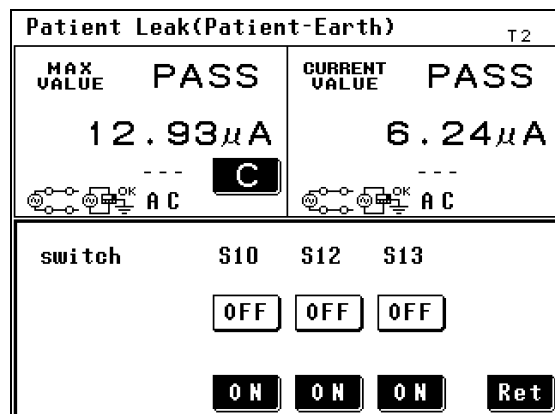

NOTE

For information on connection procedures, refer to (p. 35). Only manual measurements can be set

Changing measurement current

The indication varies depending on the network, class setting, and measurement mode selected.

See Appendix2 "List of instrument status, other test condition and special test condition" (p. A4)

On the measurement screen, press **Curr** to display the auxiliary current setting screen. The following changes can be made.

Target current

AC	Conducts AC measurement.
DC	Conducts DC measurement.
AC+DC	Conducts AC+DC measurement. (When selection is enabled)
AC PEAK	Conducts ACPeak measurement. (When selection is enabled)

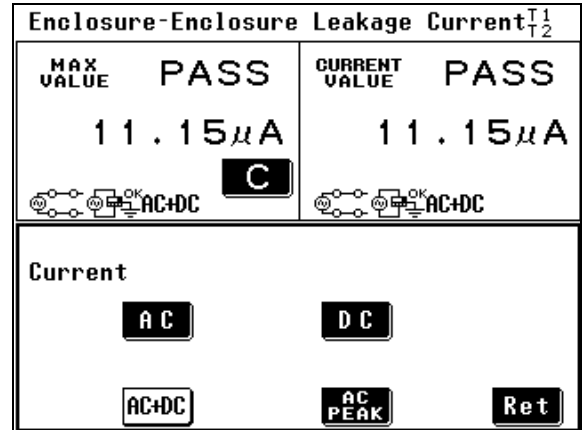

6.2 Making automatic measurements

Power supply polarity and equipment status are automatically switched during measurements. The user can select the measurement items that should be switched and set the measurement time.

Pre-test inspection

Perform a pre-test inspection.
See "3.5 Pre-Test Inspection" (p. 41)

Setup

Set up the instrument.
See "Chapter 4 Settings" (p. 47)

Starting measurements

Start becomes available in the measurement screen that appears after settings are completed. Press to automatically start measurements.

During measurements

Only **Stop** is available during automatic measurements. An intermittent beep sound during status measurements. No beep sound is output at this time when the beep setting for "key input" is turned off.

See "7.13 Setting the Beep Sound" (p. 135)

When measurements end

When measurements end, print or save the measurements as required.

On the Automatic measurement result screen, press **Print** to print the measurement data.

See "6.6 Printing Measurement Data (as required)" (p. 108)

On the Automatic measurement result screen, press **Save** to store the measurement data in internal memory.

See "6.4 Saving Measurement Data (As required)" (p. 102)

To repeat measurements, press **Ret**.

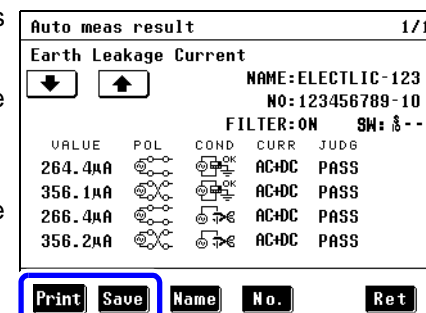
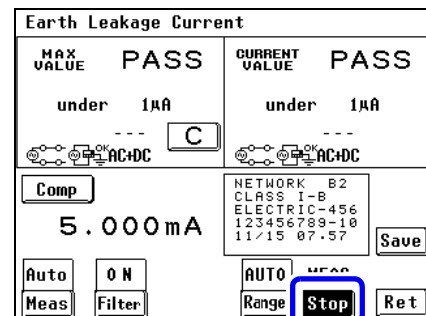
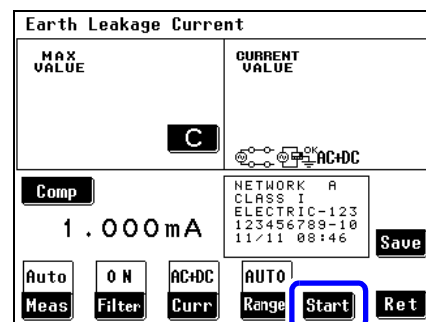

NOTE

If measurement values do not stabilize due to abrupt input fluctuations in the auto range during automatic measurements, measurements are terminated and no further measurements are made.

6.3 Measurement examples



Earth leakage current measurement

1. Connect the instrument and the equipment under test.
See "3.3 Connecting equipment under test to the instrument" (p. 36)
2. During manual measurements, Earth leakage current measurement starts upon returning to the measurement screen.
Measurement conditions can be changed during measurement.
See "6.1 Making manual measurements" (p. 79)

During automatic measurements, **Start** becomes available upon return to the measurement screen. Press **Start** to start Earth leakage current measurement.
See "Chapter 4 Settings" (p. 47)

Only **Stop** is available during automatic measurements.

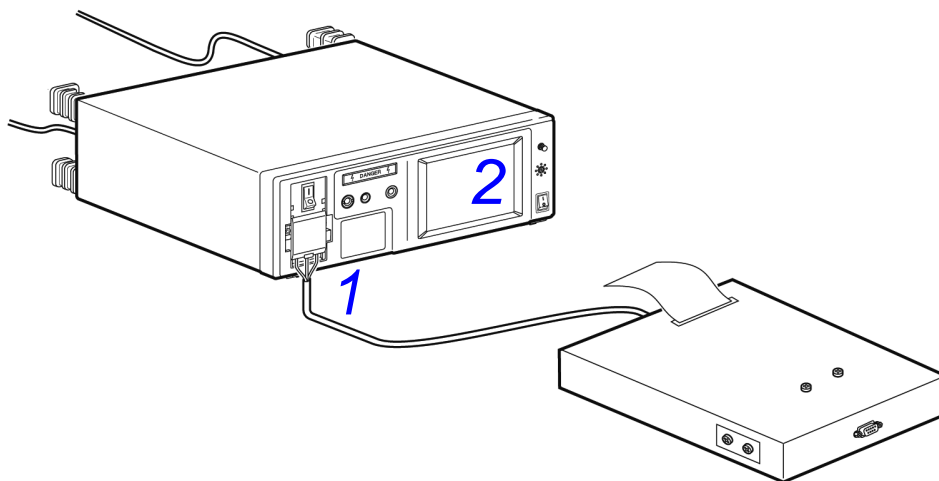

Touch current measurement

Enclosure - Earth measurement

NOTE

- Conduct leakage current measurement between enclosure and enclosure using two ungrounded locations on the enclosure.
- The terminal block is not used for internally powered equipment, although power must be supplied to [LINE IN] by a grounded two-plug power cord.
- When the protective earth conductor is disconnected (single fault), a protectively earthed enclosure is handled as a non-protectively earthed enclosure.

1. Connect the instrument and the equipment under test.
See "3.3 Connecting equipment under test to the instrument" (p. 36)
2. Connect a test lead to terminal T2.
See "5.1 Connecting the Test Lead" (p. 75)
3. Position the tip of the test lead on the enclosure of the equipment under test.
4. During manual measurements, touch current (enclosure - earth) measurement starts upon returning to the measurement screen.
Measurement conditions can be changed during measurement.
See "6.1 Making manual measurements" (p. 79)

During automatic measurements, **Start** becomes available upon return to the measurement screen. Press **Start** to start leakage current measurement between enclosure and earth.

Only **Stop** is available during automatic measurements.

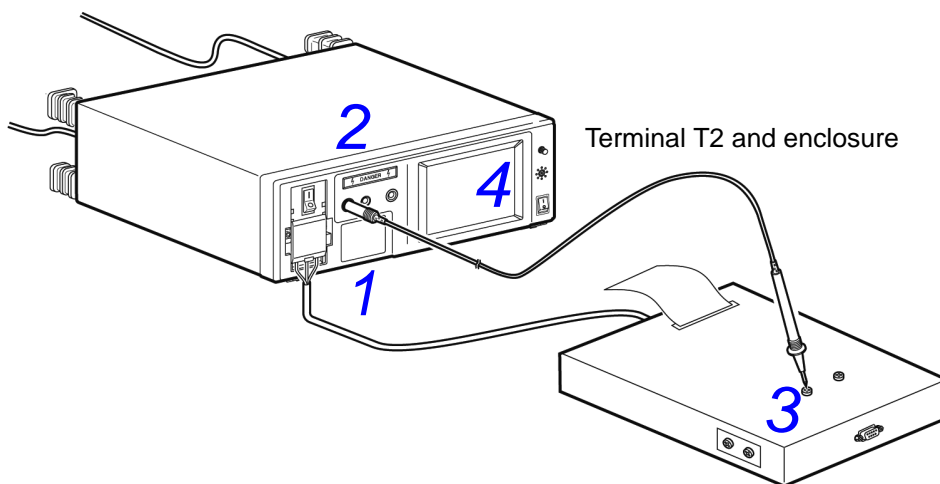

When network B1 or B2 (Other test condition, Special test condition) is selected and measurement conducted with 110% voltage application



! WARNING

- Note that when **Start** is pressed in automatic measurement mode, the instrument generates high voltage without **Apply** displayed on the screen.
- To avoid the risk of electric shock when a test lead is connected to the T3 terminal, do not touch the part of the test lead that is beyond the finger barrier. The T3 terminal outputs high voltages.



NOTE

The terminal block is not used for internally powered equipment, although power must be supplied to [LINE IN] by a grounded two-plug power cord. Also, high voltage occurring at Terminal T3 depends on this power source.

When the instrument is set to internally powered equipment, do not connect the equipment under test to an outlet or the terminal block since power is supplied from an outlet during a 110% voltage application test.

1. Connect the instrument and the equipment under test.
See "3.3 Connecting equipment under test to the instrument" (p. 36)
2. Connect test leads to terminals T2 and T3.
See "5.1 Connecting the Test Lead" (p. 75)
3. Position the tip of the test lead connected to terminal T2 on an ungrounded enclosure section of the equipment under test.
4. Position the tip of the test lead connected to terminal T3 on an ungrounded signal input section or signal output section of the equipment under test.
5. During manual measurement, **Apply** is available upon return to the measurement screen. Press **Apply** to start touch current (enclosure - earth) measurement during a single-fault condition. Pressing **Apply** applies a high voltage to the test lead connected to the T3 terminal. Press **Stop** to terminate output of high voltage.

During automatic measurements, **Start** becomes available upon return to the measurement screen. Press **Start** to start touch current (enclosure - earth) measurement under the single-fault condition.

Only **Stop** is available during automatic measurements.

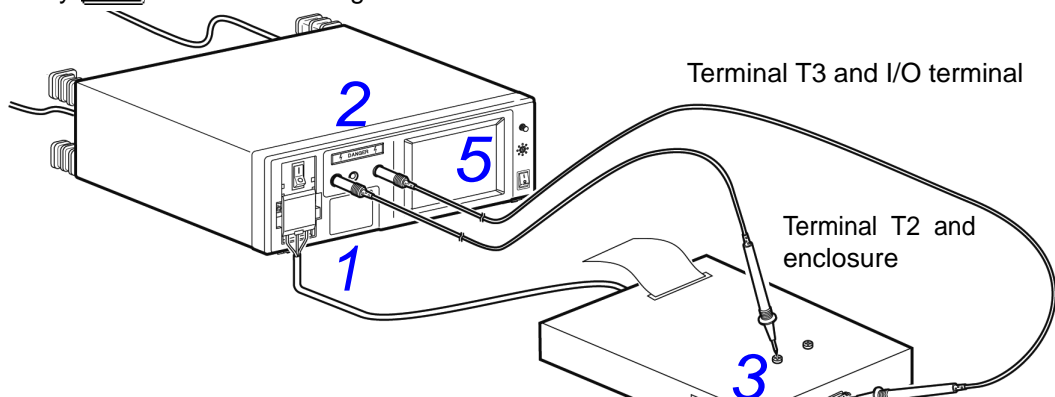

6.3 Measurement examples

Enclosure - Enclosure measurement

NOTE

- Conduct leakage current measurement between enclosure and enclosure using two ungrounded locations on the enclosure.
- The terminal block is not used for internally powered equipment.
- When the protective grounding wire is disconnected (single fault), a protectively earthed enclosure is handled as a non-protectively earthed enclosure.

1. Connect the instrument and the equipment under test.
See "3.3 Connecting equipment under test to the instrument" (p. 36)
2. Connect test leads to terminals T1 and T2.
See "5.1 Connecting the Test Lead" (p. 75)
3. Position the tips of test leads on the enclosure of the equipment under test.
4. During manual measurement, touch current (enclosure - enclosure) measurement starts upon return to the measurement screen.
Measurement conditions can be changed during measurement.
See "6.1 Making manual measurements" (p. 79)

During automatic measurements, **Start** becomes available upon return to the measurement screen. Press **Start** to start touch current (enclosure - enclosure) measurement.

Only **Stop** is available during automatic measurements.

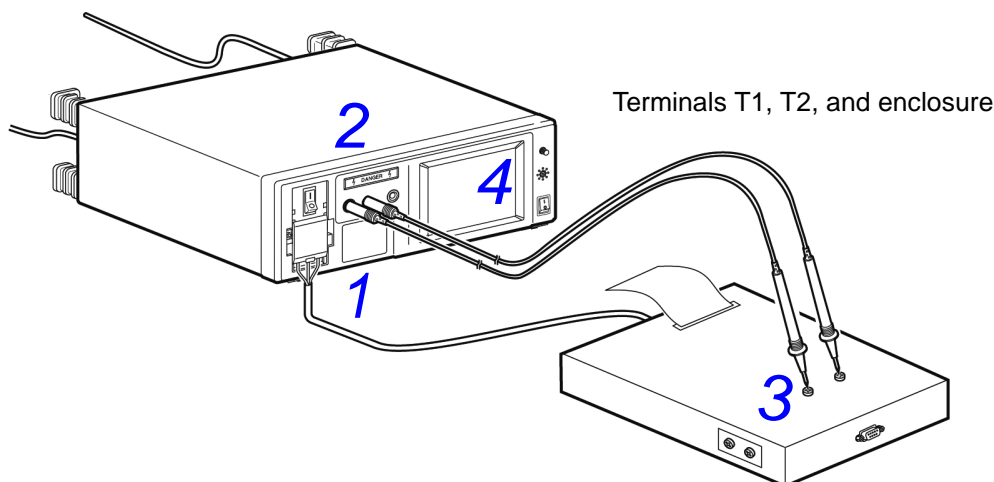

When network B1 or B2 (Other test condition, Special test condition) is selected and measurement conducted with 110% voltage application



! WARNING

- Note that when **Start** is pressed in automatic measurement mode, the instrument generates high voltage without **Apply** displayed on the screen.
- To avoid the risk of electric shock when a test lead is connected to the T3 terminal, do not touch the part of the test lead that is beyond the finger barrier. The T3 terminal outputs high voltages.

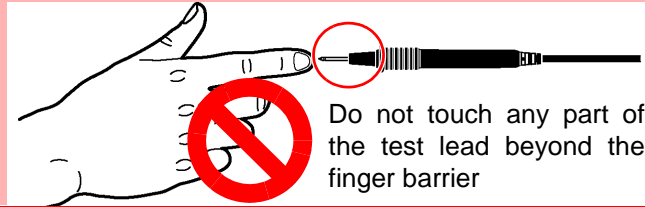

NOTE

The terminal block is not used for internally powered equipment. However, power must be supplied to this instrument's [LINE IN] connector to obtain high voltage from Terminal T3.

Do not connect the equipment under test to an outlet or the terminal block since power is supplied from an outlet during a 110% voltage application test.

1. Connect the instrument and the equipment under test.
See "3.3 Connecting equipment under test to the instrument" (p. 36)
2. Connect test leads to terminals T1, T2 and T3.
See "5.1 Connecting the Test Lead" (p. 75)
3. Position the tip of the test lead connected to terminal T1 and T2 on the enclosure of the equipment under test.
4. Position the tip of the test lead connected to terminal T3 on an ungrounded signal input section or signal output section of the equipment under test.
5. During manual measurement, **Apply** is available upon return to the measurement screen. Press **Apply** to start touch current (enclosure - enclosure) measurement during a single-fault condition. Pressing **Apply** applies a high voltage to the test lead connected to the T3 terminal. Press **Stop** to terminate output of high voltage.

During automatic measurements, **Start** becomes available upon return to the measurement screen. Press **Start** to start touch current (enclosure - enclosure) measurement under the single-fault condition.

Only **Stop** is available during automatic measurements.

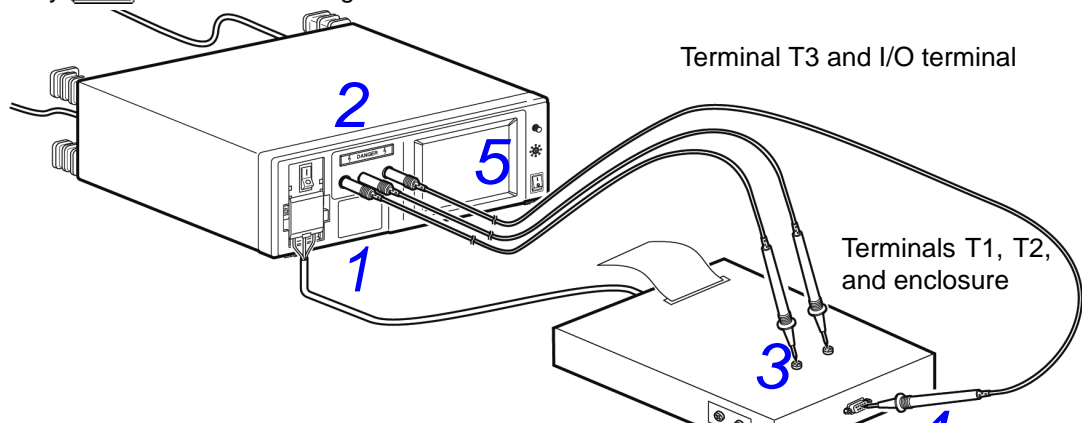

6.3 Measurement examples

Enclosure - Line measurement*

*only when selecting a network other than B1 or B2



- Note that when **Start** is pressed in automatic measurement mode, the instrument generates high voltage without **Apply** displayed on the screen.
- To avoid the risk of electric shock when a test lead is connected to the T2 terminal, do not touch the part of the test lead that is beyond the finger barrier. The T2 terminal outputs high voltages.



Do not touch any part of the test lead beyond the finger barrier

NOTE

- Conduct leakage current measurement between enclosure and enclosure using two ungrounded locations on the enclosure.
- A pre-check is made to prevent a ground fault when **Apply** is pressed. Measurement ends if the check determines a ground fault has occurred.
- If the probe is brought into contact with protective ground after the pre-check, a ground fault will occur and the measurement fuse is blown.
- When the protective grounding wire is disconnected (single fault), a protectively earthed enclosure is handled as a non-protectively earthed enclosure.

1. Connect the instrument and the equipment under test.
See "3.3 Connecting equipment under test to the instrument" (p. 36)
2. Connect a test lead to terminal T2.
3. Position the tip of the test lead on the enclosure of the equipment under test.
4. During manual measurement, **Apply** is available upon return to the measurement screen. Press **Apply** to start touch current (enclosure - line) measurement. Press **Stop** to terminate output of high voltage.

During automatic measurements, **Start** becomes available upon return to the measurement screen. Press **Start** to start touch current (enclosure - line) measurement.

Only **Stop** is available during automatic measurements.

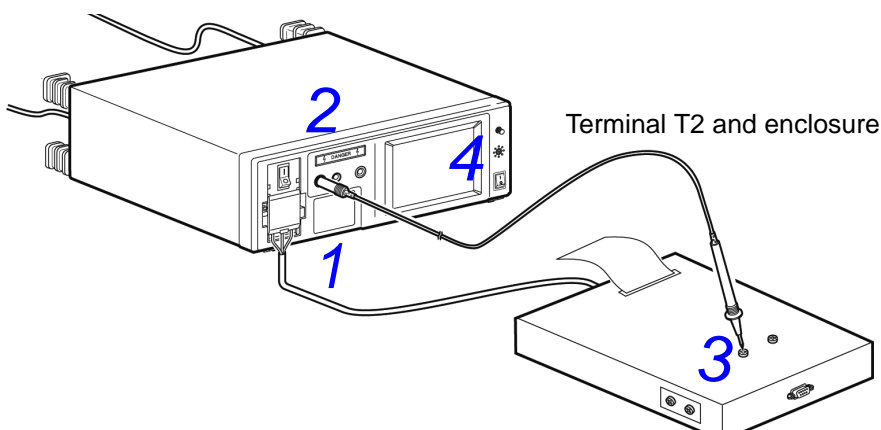



Application of leakage current measurement between enclosure and line

An equipment under test generating a voltage that exceeds rated capacity* cannot be connected to the outlet of the instrument (or the terminal block), but the T1 and T2 terminals can be used to measure touch current (enclosure - line).

* Rated current : 20 A, rated voltage : 250 V

NOTE

- Automatic measurement mode cannot be selected.
- The pre-check function is not activated automatically. Therefore, be extra careful to ensure proper connections. Testing a grounded enclosure section of the equipment under test will result in a ground fault and blown fuse for measuring operation.
-  and  are switched for managing saved measurement data. When data is not saved, measurement may be conducted with either of the settings described in 4 and 5 above.
- T2 becomes a Hi terminal; T1 becomes a Lo terminal.

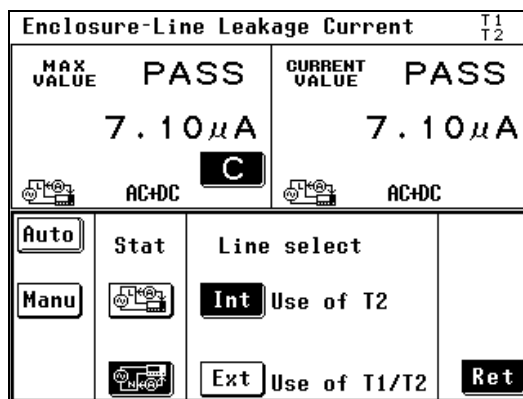

1. On the measurement screen, press **Meas** and select **Manu**. The screen for line selection then appears.
2. Press **Ext** to set [Use of T1/T2].
3. Connect test leads to terminals T1 and T2.
4. Press  to return to the measurement screen.

Connect the tip of the test lead connected to terminal T2 to the L (live) terminal of the power line for equipment under test.

Connect the tip of the test lead connected to terminal T1 to an ungrounded enclosure section of the equipment under test. Read (or save) the measurement data.

5. When  is selected, same as 4 above, connect the tip of the test lead connected to terminal T2 to the N (neutral) terminal of the power line for equipment under test, then connect the tip of the test lead connected to terminal T1 to an ungrounded enclosure section of the equipment under test. Read (or save) the measurement data.

Patient leakage current measurement* (Patient connection - Earth)

*only when selecting a network B1 or B2 (B1 selected, patient leakage current I)

Measuring the class-I equipment and class-II equipment

1. Connect the instrument and the equipment under test.
See "3.3 Connecting equipment under test to the instrument" (p. 36)
2. Connect a test lead to terminal T2.
3. Position the tip of the test lead on the applied part of the equipment under test.
4. During manual measurement, patient leakage current (patient connection - earth)/patient leakage current I measurement starts upon return to the measurement screen. Measurement conditions can be changed during measurement.
See "6.1 Making manual measurements" (p. 79)

During automatic measurements, **Start** becomes available upon return to the measurement screen. Press **Start** to start patient leakage current (patient connection - earth)/patient leakage current I measurement.

Only **Stop** is available during automatic measurements.

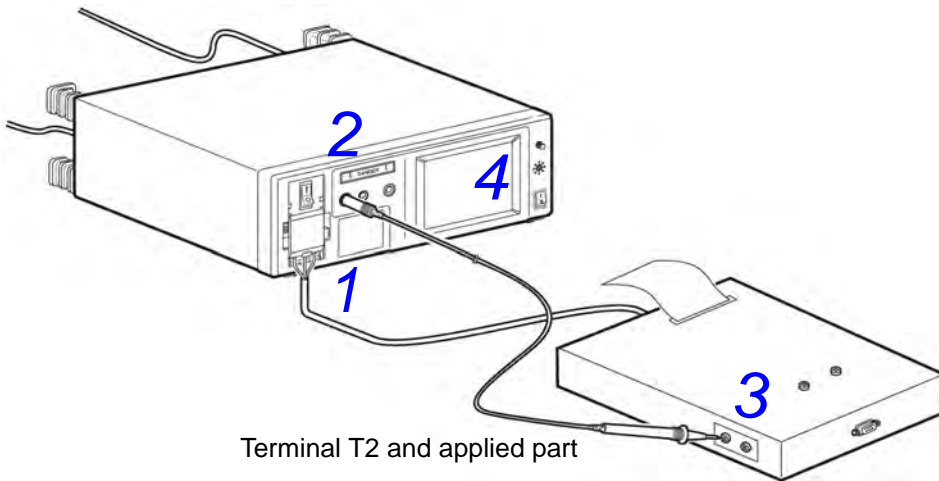

Measuring the internally powered equipment 1

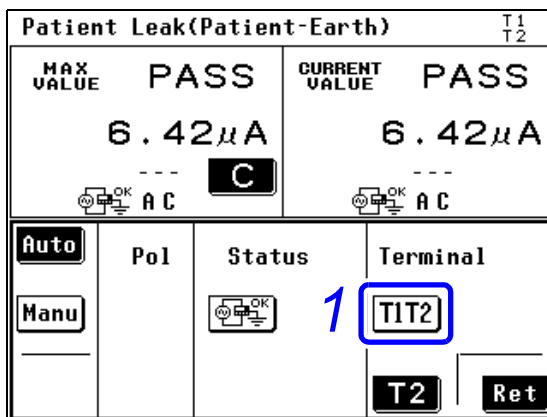

1. Press **Meas** in the measurement screen and select **TIT2** under measured terminal.
2. Connect test leads to terminals T1 and T2.
3. Place the tip of test lead connected to the T1 terminal on the enclosure of the equipment under test.
4. Position the tip of the test lead connected to terminal T2 on the applied part of the equipment under test.
5. During manual measurement, patient leakage current (patient connection - earth) measurement starts upon return to the measurement screen. Measurement conditions can be changed during measurement.

See "6.1 Making manual measurements" (p. 79)

During automatic measurements, **Start** becomes available upon return to the measurement screen. Press **Start** to start patient leakage current (patient connection - earth) measurement.

Only **Stop** is available during automatic measurements.

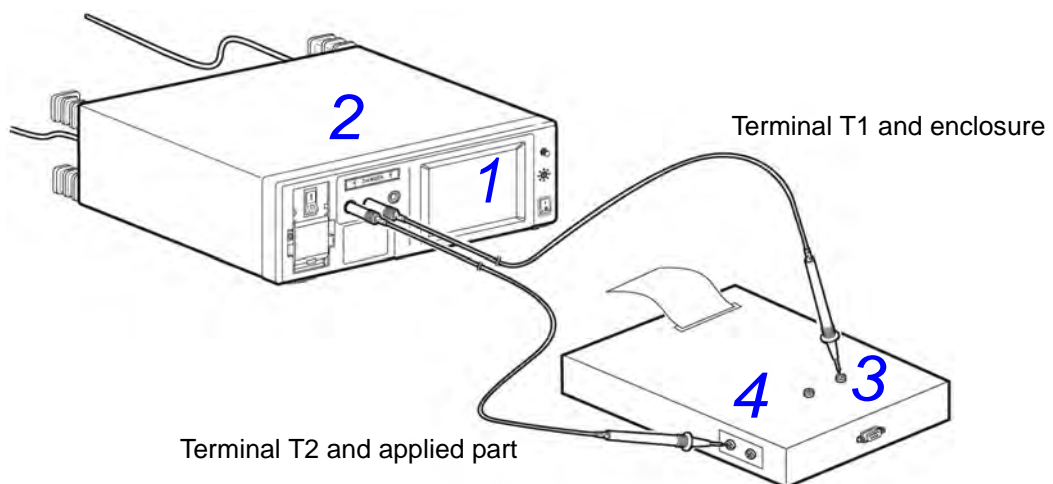

NOTE

When the instrument is set to internally powered equipment, even if the breaker is turned On, the power supply to the equipment under test will be interrupted (grounding connection will also be interrupted).

Measuring the internally powered equipment 2

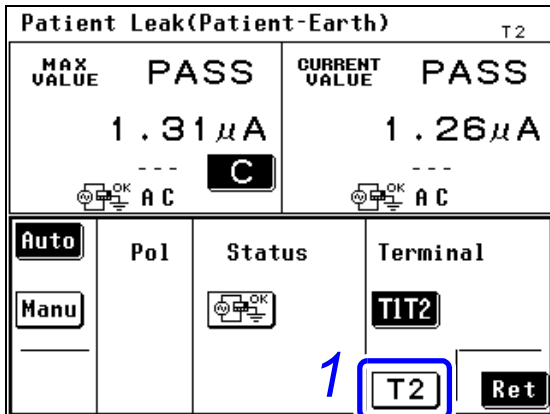

1. Press **Meas** in the measurement screen and select **T2** under measured terminal.
2. Connect test leads to terminals T2.
3. Position the tip of the test lead connected to terminal T2 on the applied part of the equipment under test.
4. During manual measurement, patient leakage current (patient connection - earth) measurement starts upon return to the measurement screen. Measurement conditions can be changed during measurement.
See "6.1 Making manual measurements" (p. 79)

During automatic measurements, **Start** becomes available upon return to the measurement screen.

Press **Start** to start patient leakage current (patient connection - earth) measurement.

Only **Stop** is available during automatic measurements.

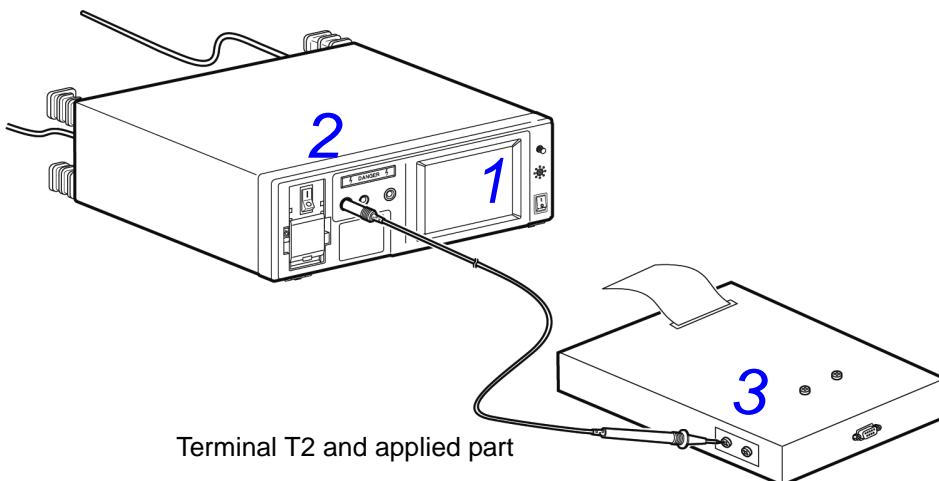

Terminal T2 and applied part

NOTE

When the instrument is set to internally powered equipment, even if the breaker is turned On, the power supply to the equipment under test will be interrupted (grounding connection will also be interrupted).

Patient leakage current measurement* (external voltage on a SIP/SOP)

*only when selecting network B1 or B2 and providing equipment with a Type B applied part (B1 selected, patient leakage current II)

! WARNING

- Note that when **Start** is pressed in automatic measurement mode, the instrument generates high voltage without **Apply** displayed on the screen.
- To avoid the risk of electric shock when a test lead is connected to the T3 terminal, do not touch the part of the test lead that is beyond the finger barrier. The T3 terminal outputs high voltages.



NOTE

- If insulation of the signal input/output section and applied part is low due to the output impedance ($22.5 \text{ k} \pm 3 \text{ k}\Omega$) of the 110% voltage application function, a value at or below the allowable value may be detected. Take this into consideration when setting the allowable value.
- The terminal block is not used for internally powered equipment. However, power must be supplied to this instrument's [LINE IN] connector to obtain high voltage from Terminal T3. Do not connect the equipment under test to an outlet or the terminal block since power is supplied from an outlet during a 110% voltage application test.

6.3 Measurement examples

1. Connect the instrument and the equipment under test.
See "3.3 Connecting equipment under test to the instrument" (p. 36)
2. Connect test leads to terminals T2 and T3.
3. Position the tip of the test lead connected to terminal T2 on the applied part of the equipment under test.
4. Position the tip of the test lead connected to terminal T3 on an ungrounded signal input section or signal output section of the equipment under test.
5. During manual measurement, **Apply** is available upon return to the measurement screen. Press **Apply** to start patient leakage current (external voltage on a SIP/SOP)/patient leakage current II measurement.
Pressing **Apply** applies a high voltage to the test lead connected to the T3 terminal.
Press **Stop** to terminate output of high voltage.

During automatic measurements, **Start** becomes available upon return to the measurement screen. Press **Start** to start patient leakage current (external voltage on a SIP/SOP)/patient leakage current II measurement.

Only **Stop** is available during automatic measurements.

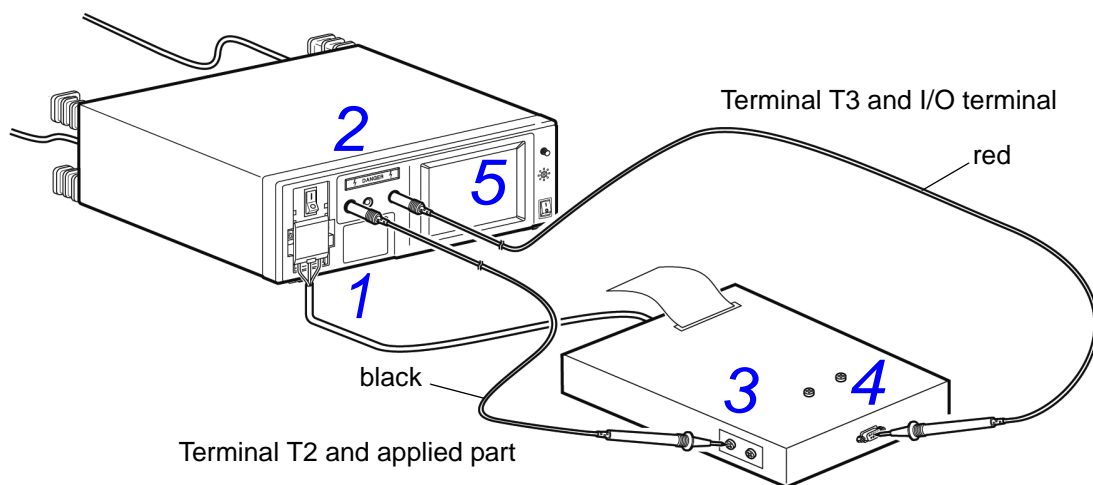

Patient leakage current measurement* (external voltage on a specific F-type applied part)

*only when selecting network B and providing equipment with a Type BF or Type CF applied part
(B1 selected, patient leakage current III)

WARNING

- Note that when **Start** is pressed in automatic measurement mode, the instrument generates high voltage without **Apply** displayed on the screen.
- To avoid the risk of electric shock when a test lead is connected to the T2 terminal, do not touch the part of the test lead that is beyond the finger barrier. The T2 terminal outputs high voltages.

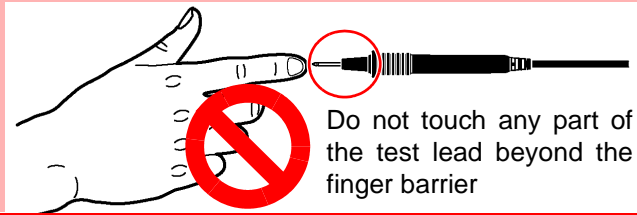

NOTE

- If insulation of the applied part and earth is low due to the output impedance ($22.5\text{ k} \pm 3\text{ k}\Omega$) of the 110% voltage application function, a value at or below the allowable value may be detected. Take this into consideration when setting the allowable value.
- The terminal block is not used for internally powered equipment. However, power must be supplied to this instrument's [LINE IN] connector to obtain high voltage from Terminal T3. Do not connect the equipment under test to an outlet or the terminal block since power is supplied from an outlet during a 110% voltage application test.
- The enclosure of the equipment under test (internally powered equipment) is grounded.

6.3 Measurement examples

1. Connect the instrument and the equipment under test.
See "3.3 Connecting equipment under test to the instrument" (p. 36)
2. Connect a test lead to terminal T2.
3. Position the tip of the test lead on the applied part of the equipment under test.
4. During manual measurement, **Apply** is available upon return to the measurement screen. Press **Apply** to start patient leakage current (external voltage on a specific F-type applied part)/patient leakage current III measurement.
Pressing **Apply** applies a high voltage to the test lead connected to the T2 terminal.
Press **Stop** to terminate output of high voltage.

During automatic measurements, **Start** becomes available upon return to the measurement screen. Press **Start** to start patient leakage current (external voltage on a specific F-type applied part)/patient leakage current III measurement.

Only **Stop** is available during automatic measurements.

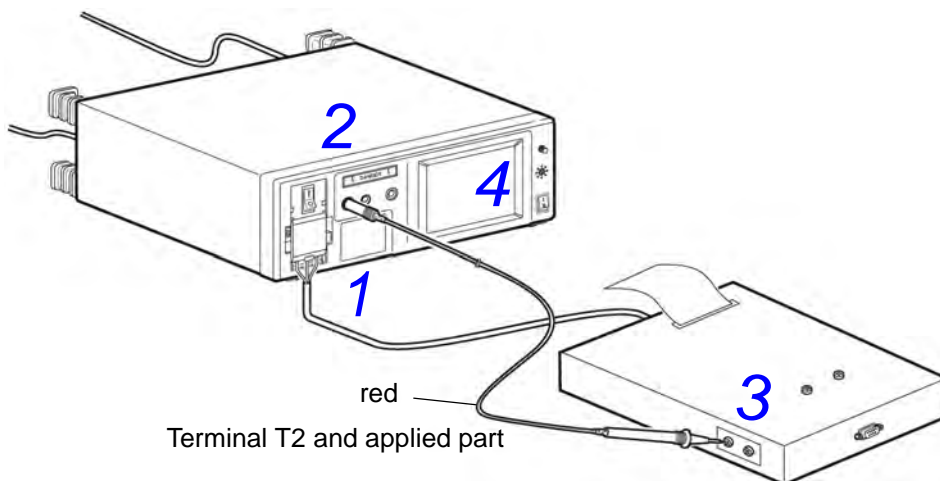

Patient leakage current measurement* (external voltage on metal accessible part not protectively earthed)

* only when selecting a network B2

! WARNING

- Note that when **Start** is pressed in automatic measurement mode, the instrument generates high voltage without **Apply** displayed on the screen.
- To avoid the risk of electric shock when a test lead is connected to the T2 terminal, do not touch the part of the test lead that is beyond the finger barrier. The T2 terminal outputs high voltages.

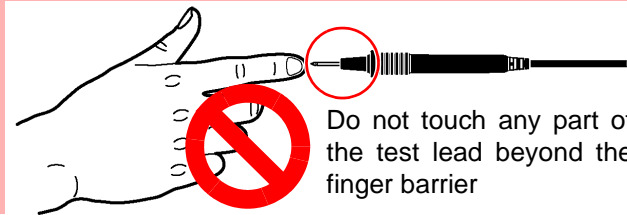

NOTE

- If insulation of the signal input/output section and applied part is low due to the output impedance ($22.5 \text{ k} \pm 3 \text{ k}\Omega$) of the 110% voltage application function, a value at or below the allowable value may be detected. Take this into consideration when setting the allowable value.
- The terminal block is not used for internally powered equipment. However, power must be supplied to this instrument's [LINE IN] connector to obtain high voltage from Terminal T3. Do not connect the equipment under test to an outlet or the terminal block since power is supplied from an outlet during a 110% voltage application test.

6.3 Measurement examples

1. Connect the instrument and the equipment under test.
See "3.3 Connecting equipment under test to the instrument" (p. 36)
2. Connect test leads to terminals T2 and T3.
3. Position the tip of the test lead connected to terminal T2 on the applied part of the equipment under test.
4. Place the tip of the test lead connected to the T3 terminal on a metal accessible part not protectively earthed on the equipment under test.
5. During manual measurement, **Apply** is available upon return to the measurement screen. Press **Apply** to start patient leakage current (external voltage on metal accessible part not protectively earthed) measurement.
Pressing **Apply** applies a high voltage to the test lead connected to the T3 terminal.
Press **Stop** to terminate output of high voltage.

During automatic measurements, **Start** becomes available upon return to the measurement screen. Press **Start** to start patient leakage current (external voltage on metal accessible part not protectively earthed) measurement.
Only **Stop** is available during automatic measurements.

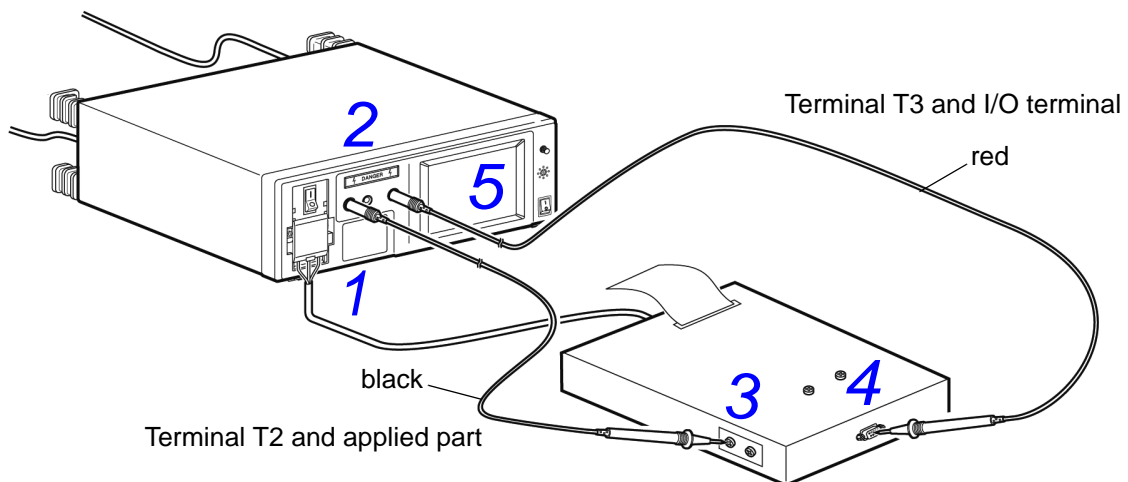

Patient auxiliary current measurement*

*only when selecting a network B1 or B2

NOTE

The terminal block is not used for internally powered equipment.

1. Connect the instrument and the equipment under test.
See "3.3 Connecting equipment under test to the instrument" (p. 36)
2. Connect test leads to terminals T1 and T2.
3. Position the tips of test leads on the applied part of the equipment under test.
4. During manual measurement, patient auxiliary current measurement starts upon return to the measurement screen.
Measurement conditions can be changed during measurement.

During automatic measurements, **Start** becomes available upon return to the measurement screen. Press **Start** to start patient auxiliary current measurement.

Only **Stop** is available during automatic measurements.

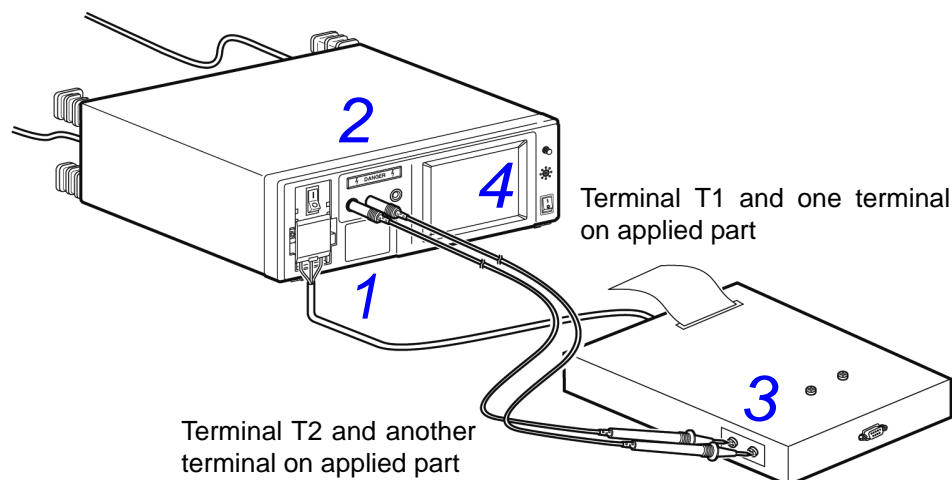

Total patient leakage current measurement* (Patient connection - Earth)

*only when selecting a network B2

Measuring the class-I equipment and class-II equipment

1. Connect the instrument and the equipment under test.
See "3.3 Connecting equipment under test to the instrument" (p. 36)
2. Connect a test lead to terminal T2.
3. Place the tip of the test lead on the jig to measure the leakage current from the jig.
4. Place all the applied parts of the equipment under test in contact with each other.
5. Place the tip of the test lead on the applied parts of the equipment under test.
6. During manual measurement, total patient leakage current (Patient connection - Earth) measurement starts upon return to the measurement screen.
Measurement conditions can be changed during measurement.
See "6.1 Making manual measurements" (p. 79)

During automatic measurements, **Start** becomes available upon return to the measurement screen. Press **Start** to start total patient leakage current (Patient connection - Earth) measurement.

Only **Stop** is available during automatic measurements.

7. Any measurement result within the allowable value is acceptable.
If a FAIL is produced, the result of the leakage current test is a PASS if the total leakage current value less the leakage current value for the jig is within the allowable value.

NOTE

The instrument cannot alone measure the leakage current for all applied parts.
The customer will have to find a jig that can bundle the applied parts.

Free current measurement (Enclosure - Enclosure)

Use the selected network to select any current range (AC, DC, AC + DC, AC peak) and any measurement range (50 μ A, 500 μ A, 5 mA, 50 mA).

NOTE

- Conduct leakage current measurement between enclosure and enclosure using two ungrounded locations on the enclosure.
- The terminal block is not used for internally powered equipment.
- When the protective grounding wire is disconnected (single fault), a protectively earthed enclosure is handled as a non-protectively earthed enclosure.
- Free current measurement does not permit automatic measurements.

1. Connect the instrument and the equipment under test.
See "3.3 Connecting equipment under test to the instrument" (p. 36)
2. Connect test leads to terminals T1 and T2.
3. Position the tip of the test lead on the enclosure of the equipment under test.
4. Free current measurement starts upon return to the measurement screen. Measurement conditions can be changed during measurement.

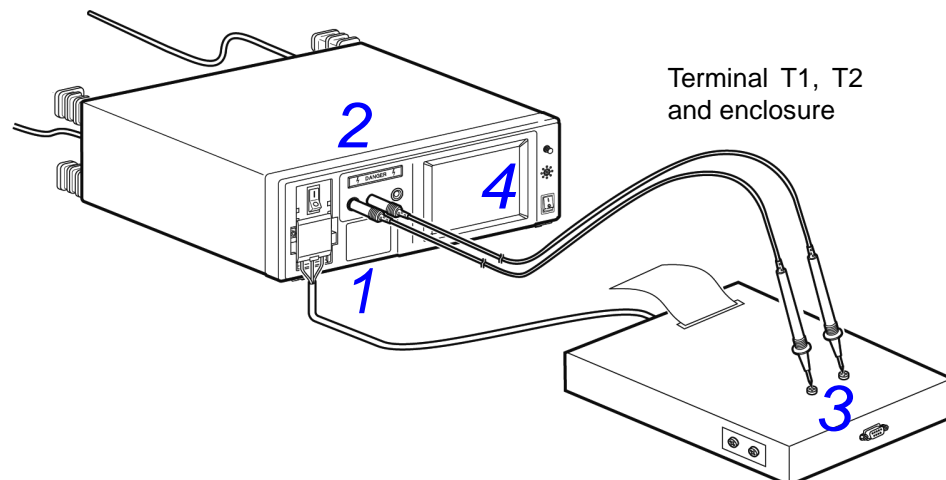

6.4 Saving Measurement Data (As required)

Use the steps below to save measurement data (maximum values) in internal memory. When measurements end, saved data can be confirmed in the save data reference screen.
 See "Checking Saved Measurement Data" (p. 104)

Manual measurements

Earth Leakage Current	
MAX VALUE PASS 355.2 μ A	CURRENT VALUE PASS 263.4 μ A
AC+DC <input type="checkbox"/> C	
1 Saves Measurement Data (max value) 2 Saves condition setting data 3 Return	

1. On the measurement screen, press **Save** to display the screen for selecting the data to be saved.

Press **1**. A screen appears to confirm whether to save the measurement data.

Press **2** to save measurement conditions.
 See "6.5 Saving Measurement Conditions (Panel Save Function) (as required)" (p. 106)

Press **3** to return to the measurement screen.

Patient Leak(Patient-Earth) T2	
MAX VALUE PASS 1.31 μ A	CURRENT VALUE PASS 1.24 μ A
AC <input type="checkbox"/> C	
Save max value OK? Yes No	Name & No. Setup Name ELECTRIC-012 No. 123456789-10

2. Save measurement data.

Press **Yes** to save the data.

Press **No** to return to the measurement screen without saving the data.

To change the equipment name or control number, press **Name** or **No.** and enter the new name or number.
 See "Registering an Equipment Name/Control Number" (p. 50)

Patient Leak(Patient-Earth) T2	
MAX VALUE PASS 1.31 μ A	CURRENT VALUE PASS 1.24 μ A
AC <input type="checkbox"/> C	
Overwrite data OK? Yes No	Name & No. Setup Name ELECTRIC-012 No. 123456789-10

3. If the data is already saved, a message appears and asks whether to overwrite the existing data.

Press **Yes** to overwrite the existing data.
 To switch the memory used to save data, register the data under a different equipment name and control number.

Press **No** to return to the measurement screen without saving the data.

Earth Leakage Current	
MAX VALUE PASS 5.29 μ A	CURRENT VALUE PASS 5.29 μ A
AC+DC <input type="checkbox"/> C	
No more memory. Data on up to 100 units can be saved.	Name & No. Setup Name ABCDEFGHIJKL No. 00000000102
Ret	

Each registered equipment name/control number represents one unit. The instrument can save up to 100 units. Each unit can be saved with the results of all measurement items corresponding to the network and grounding class.

If the 100 unit memory capacity is exceeded, the screen shown on the left appears. Up to 2,000 maximum values can be saved. If this limit is exceeded, the screen displays "No more memory."

See "Deleting Saved Data" (p. 105)

Automatic measurements

Auto meas result		1/1	
Earth Leakage Current			
↓ ↑		NAME: ELECTLIC-123	
		NO: 123456789-10	
		FILTER: ON SW: - -	
VALUE	POL	COND	CURR JUDG
264.4mA			AC+DC PASS
356.1mA			AC+DC PASS
266.4mA			AC+DC PASS
356.2mA			AC+DC PASS
Save		Name No. Ret	

1. When automatic measurements end, a list of measurement appears as shown on the screen.
2. To save this data, enter a name and No. and press **Save**.

When a remote command is received (and remote status is engaged) during automatic measurement, the automatic measurement result screen does not appear.

3. Press **Ret** to return to the system screen.

Saving data during automatic measurements

Auto meas result		1/2	
Enclosure-Enclosure Leakage Current			
↓ ↑		NAME: ELECTLIC-123	
		NO: 123456789-10	
		FILTER: OFF	
VALUE	POL	COND	CURR JUDG
23.35mA			AC+DC PASS
14.24mA			AC+DC PASS
5.60mA			AC+DC PASS
14.05mA			AC+DC PASS
Change Name or No.		Ret	

When saving measured data after changing the network in the same measurement mode, the screen shown at left may appear.

Press **Ret** and change the name of the instrument.

The screen shown at left may appear when saving measurement data.

If it appears, press **Ret** and change the name of the instrument.

6.4 Saving Measurement Data (As required)

Checking Saved Measurement Data

1. Press **System** on the initial screen to display the system screen.
2. Press **Save Data** to display the measurement data reference screen.

This screen displays the measurement data saved by using the measurement screen. It also allows the deletion and printing of measurement data (when the optional 9442 PRINTER is connected).

Unit number of data on screen Total number of data units

Unit page of data on screen

Measurement mode

Network :Type of network
CLASS :Grounding class
APPLY :Applied part
NAME :Equipment name
No :Control number
DATE :Date

Combinations of maximum value, judgement result, and measurement conditions at maximum value acquisition in each mode

MODE	MAX VALUE	JUDGE	STAT.
Earth Leak	0.665mA	PASS	ON AC+DC
TC(En-En)	0.680mA	FAIL	---
PL(Pa-Ea)	59.4mA	PASS	ON AC+DC
TPL(Pa-Ea)	0.674mA	FAIL	---

Measurement data reference screen

Displaying Saved Measurement Data

1. Press **All** on the measurement data reference screen to display the measurement data reference (details) screen.

When there are six or more combinations, use **↑** and **↓** to scroll the page.

The sample screen on the left shows four combinations. The "1/1" indication at the top of the screen means that the data is shown only on one page.

2. Press **Ret** to return to the measurement data reference screen.

VALUE :Maximum value
JUDG :Judgement result
POL :Power supply polarity
COND :Equipment status
(normal condition, fault condition)
FILT :Network filter setting
CURR :Target current

CON2 :Other test condition,
Special test condition
SW :S10, S12, S13 status

Saved data reference 1/1

Touch Current(Enclosure-Enclosure)
NAME: ELECTRIC-123 NO: 123456789-10

VALUE	JUDG	POL	COND	FILT	CURR
19.47mA	PASS	~	ON	AC+DC	---
19.46mA	PASS	~	ON	AC+DC	---
<=1mA	LOW	~	ON	AC+DC	---
19.46mA	PASS	~	ON	AC+DC	---
0.680mA	FAIL	~	ON	AC+DC	---

Measurement data reference screen (details)

Saved data reference 1/1

Touch Current(Enclosure-Enclosure)
NAME: ELECTRIC-123 NO: 123456789-10

VALUE	JUDG	CON2	SW
19.47mA	PASS	---	---
19.46mA	PASS	---	---
<=1mA	LOW	---	---
19.46mA	PASS	---	---
0.680mA	FAIL	---	---

Measurement data reference screen (details)

Selecting Saved Measurement Data

Saved data reference
 DATA: 1/2 NETWORK :B2
 CLASS :I APPLY :B
 NAME: ELECTRIC-123
 No: 123456789-10
 DATE: 2010/11/10
 PAGE: 1/1
 PAGE DOWN PAGE UP

MODE	MAX VALUE	JUDGE	STAT.
Earth Leak	0.665mA	PASS	⊕-⊖ ⊕-⊖ ⊕-⊖ ⊕-⊖
TC(En-En)	0.680mA	FAIL	⊕-⊖ ⊕-⊖ ⊕-⊖ ⊕-⊖
PL(Pa-Ea)	59.4μA	PASS	0 N AC+DC
TPL(Pa-Ea)	0.674mA	FAI	---

 Del All Mode Ret

Measurement data reference screen

- Press **MODE** to switch the mode used for the data unit.
On the sample screen, the mode changes in the following order:
Earth Leak → **TC(En-En)** → **PL(Pa-Ea)** → **TPL(Pa-Ea)**.
- Press **Ret** to return to the system screen.

List of measurement modes (varies depending on network types)

Earth Leak	Earth leakage current	PL (Pa-Ea)	Patient leakage current (Patient connection - Earth)
En-Ea Leak	Enclosure - Earth leakage current	PL-SIPSOP	Patient leakage current (SIP/SOP)
En-En Leak	Enclosure - Enclosure leakage current	PL (F)	Patient leakage current (F-type applied part)
En-Li Leak	Enclosure - Line leakage current	PL (MP)	Patient leakage current (Metal accessible part)
Pat.Leak I	Patient leakage current I	TPL (Pa-Ea)	Total patient leakage current (Patient connection - Earth)
Pat.Leak II	Patient leakage current II	TPL-SIPSOP	Total patient leakage current (SIP/SOP)
Pat.Leak III	Patient leakage current III	TPL (F)	Total patient leakage current (F-type applied part)
TC (En-Ea)	Touch current (Enclosure - Earth)	TPL (MP)	Total patient leakage current (Metal accessible part)
TC (En-En)	Touch current (Enclosure - Enclosure)	Pat.Aux.	Patient auxiliary current
TC (En-Li)	Touch current (Enclosure - Line)	Free	Free current measurement

NOTE

About data unit sorting

The sort function rearranges data unit numbers in sequence based on the equipment name (1st character (A, B, C, ..., Z, 0, 1, 2, ..., 9, -), 2nd character, ..., 12th character), and control number. When a new data unit is added, the data units are sorted again.

Deleting Saved Data

Saved data reference
 DATA: 1/2 NETWORK :B2
 CLASS :I APPLY :B
 NAME: ELECTRIC-123
 No: 123456789-10
 DATE: 2010/11/10
 PAGE: 1/1
 PAGE DOWN PAGE UP

MODE	MAX VALUE	JUDGE	STAT.
Earth Leak	0.665mA	PASS	⊕-⊖ ⊕-⊖ ⊕-⊖ ⊕-⊖
TC(En-En)	0.680mA	FAIL	⊕-⊖ ⊕-⊖ ⊕-⊖ ⊕-⊖
PL(Pa-Ea)	59.4μA	PASS	0 N AC+DC
TPL(Pa-Ea)	0.674mA	FAIL	---

 Del All Mode Ret

Measurement data reference screen

- Use **↑** and **↓** to select a data unit to delete.
- Press **Del**.
A confirmation screen appears.
- Press **Yes** to delete the selected data unit.
To delete two or more data units, repeat steps 1 through 3.
- Press **Ret** to return to the system screen.

NOTE

The initialization screen can be used to delete all saved data.

6.5 Saving Measurement Conditions (Panel Save Function) (as required)

Up to 30 panels of measurement condition data can be saved in internal memory.

Saved measurement conditions can be read at a later date.

See "7.2 Panel Load(Loading Saved Measurement Conditions)" (p. 120)

The following conditions are saved in a panel.

- Network
- Measurement mode
- Filter ON/OFF
- Grounding class
- Registered equipment name/control number
- Allowable value (normal condition, fault condition, upper limit value, lower limit value)
- Manual/Auto measurement
- Measurement range
- Target current
- Equipment status (power supply polarity, fault mode, SW status, Other test condition (Other applied voltages), Special test condition (Specific applied voltage), combination of items for automatic measurement)
- Measuring time/measurement delay time for automatic measurement

Saved panels can be initialized.

See "7.3 Initializing the Instrument" (p. 121)

6.5 Saving Measurement Conditions (Panel Save Function) (as required)

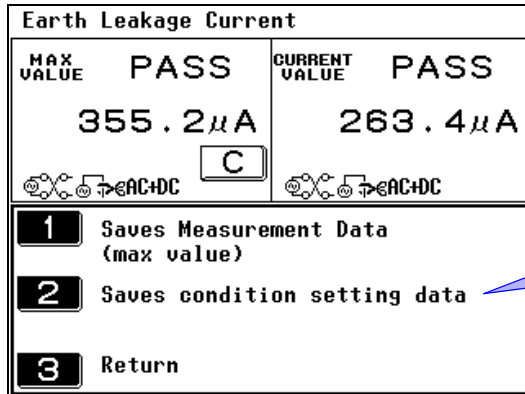

1. On the measurement screen, press **Save** to display the screen for selecting the data to be saved.

Press **2** to display a screen for selecting panel numbers where measurement conditions are saved.

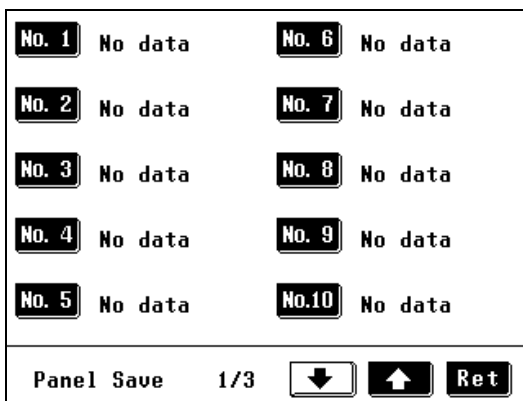

2. Select a panel number for saving data. (Select a panel with "No Data" indicated.)
If a panel is not displayed on the screen, press **↑** **↓** to display the page showing the desired panel.
Note that if the selected panel already contains data, the existing data will be overwritten by new data.

When a panel number is selected, a panel save confirmation screen then appears.

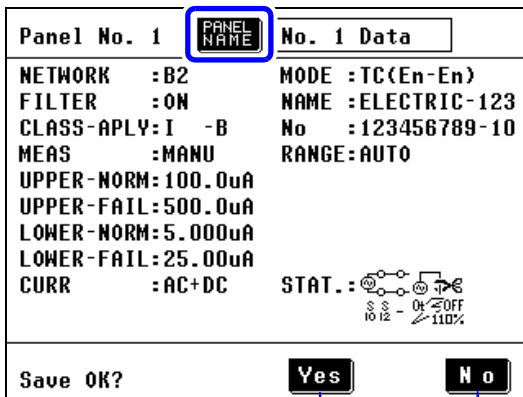

3. Press **PANEL NAME** and enter a panel name.
Entering a panel name enables data to be easily identified when read out later.
If no panel name is entered, the panel is automatically assigned a name consisting of the selected panel number followed by "Data"
(e.g., "No. 1 Data")

See For details of the method of assigning a panel name: "Registering an Equipment Name/Control Number" (p. 50)

Press **Yes** to save the data and return to the previous screen.
Press **No** to return to the previous screen without saving the data.

NOTE

If touch current (Enclosure - Line leakage current) and patient leakage current conditions are included, allowable values for normal condition do not apply and UPPER-NORM and LOWER-NORM : (value) are not indicated.

6.6 Printing Measurement Data (as required)

Setting up and connecting a printer



Preparation before Connection

The maximum value, measurement conditions, and other data can be printed when the optional 9442 Printer is connected with the 9444 Connection cable.

Necessary items

- 9442 Printer
- 9443-01 AC Adapter with power cord (for Japan)
- 9443-02 AC Adapter (for EU)
- 1196 Recording paper

To connect the main instrument and printer :

- 9444 Connection Cable

Setting of the 9442 Printer

Change the settings of the software dip switches (DIP SW) to use the 9442 for the ST5540 or ST5541.

- The 9442 is shipped with the function settings for use with the Hioki 3166 Clamp on power HiTESTER. Before using, always change the settings of the DIP switches.
- For details on the operations and handling of the printer, refer to the operation manual supplied to the printer.
- For the printer, use the 1196 Recording paper (thermal paper, 10 rolls) or an equivalent.

Procedure

1. Turn off the power of the 9442.
2. Turn on the power while pressing the ON LINE button. Release the button after a list of the current settings starts printing out.

The print out of the current settings is followed by the prompt:

Continue? :Push 'On-line SW'

Write? :Push 'Paper feed SW'

3. Press the ON LINE button to change the settings.
"Dip SW-1" is printed to make a settings for DIP SW 1.

6.6 Printing Measurement Data (as required)

4. For switches one to eight of the DIP SW1, set the ON/OFF status as shown in the table below.

To set to ON, press the ON LINE button once and to set to OFF, press the FEED button once.

The setting is printed out after the **ON LINE** or **FEED** button is pressed to allow to confirm the new setting. To change the settings, repeat from step 1.

[Redacted] : Use these settings for the HiTESTER.

Software DIP SW 1 settings

Switch No.	Function	ON (Press ON LINE)	OFF (Press FEED)
1	Input method	Parallel	Serial
2	Printing speed	High	Low
3	Auto loading	Enable	Off
4	CR function	Carriage return and line feed	Carriage return
5	Setting command	Enable	Disable
6	Printing density (set to 100%)		OFF
7		ON	
8		ON	

After switch eight is set, the following messages are printed out.

Continue? :Push 'On-line SW'

Write? :Push 'Paper feed SW'

5. Press the ON LINE button and provide the following settings for DIP SW2 and DIP SW3.

Software DIP SW 2 settings

Switch No.	Function	ON (Press ON LINE)	OFF (Press FEED)
1	Print mode	Normal printing (40 columns)	Condensed printing (80 columns)
2	User-defined characters back-up	Enable	Disable
3	Character type	Ordinary characters	Special characters
4	Zero font	0	∅
5	International character set	ON	
6		ON	
7		ON	
8		ON	

Software DIP SW 3 settings

Switch No.	Function	ON (Press ON LINE)	OFF (Press FEED)
1	Data bit length	8 bits	7 bits
2	Parity permission	Without	With
3	Parity condition	Odd	Even
4	Flow control	H/W BUSY	XON/XOFF
5	Baud rate (19200bps)		OFF
6		ON	
7		ON	
8			OFF

6. After setting for the switch number 8 of DIP SW 3 is made, press the ON LINE or FEED switch to complete settings.

The following message is printed out

6.6 Printing Measurement Data (as required)

Connect the printer

Connect the 9442 Printer to the RS-232C connector of the HiTESTER.

Before connection, complete any necessary settings on both the printer(p. 108) and the ST5540 or ST5541(p. 134).



To avoid electric shock, turn off the power to all devices before plugging or unplugging any cables or peripherals.

Procedure

1. Turn off the power of the main instrument and printer.
2. Connect the 9444 Connection Cable between the ST5540 or ST5541 and the printer.

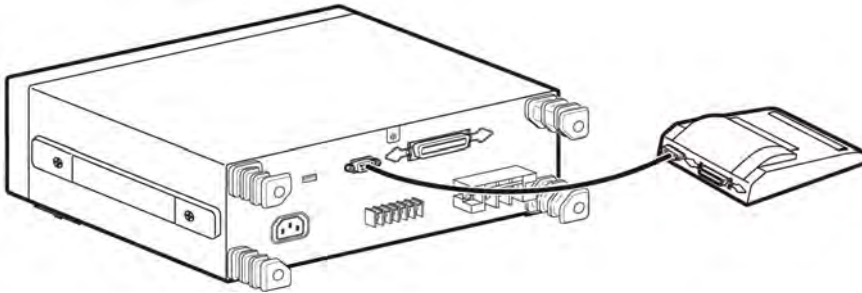

Printing

Measurement data (maximum values) can be printed out.

NOTE

- The 9442 Printer (option) is required for printing measurement data.
 - The **Stop** key is displayed during printing. To abort printing, press **Stop**.
 - Set the interface to "Printer" before printing.
- See "7.12 Interface Setting (For Communication and Printing)" (p. 133)

When setting measurement method to Manual

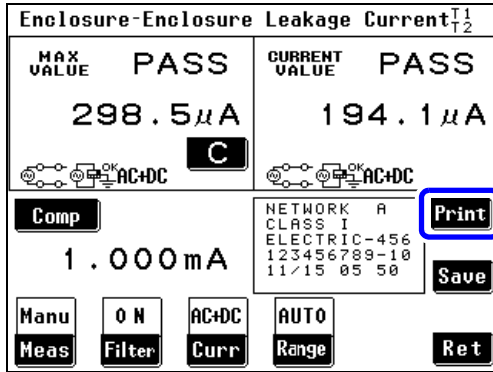

On the measurement screen, press **Print** to start printing.

Manual measurement screen

When setting measurement method to Auto

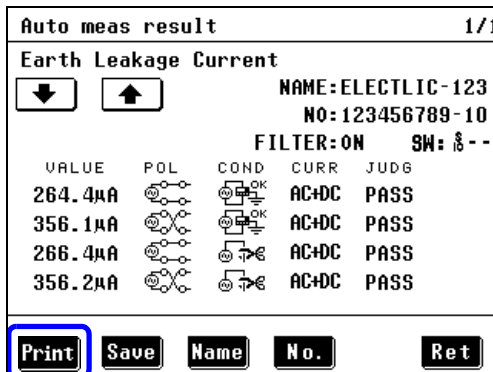

After automatic measurement ends, press **Print** on the measurement result screen to start printing.

Screen displayed after automatic measurement ends

Printing Saved Data

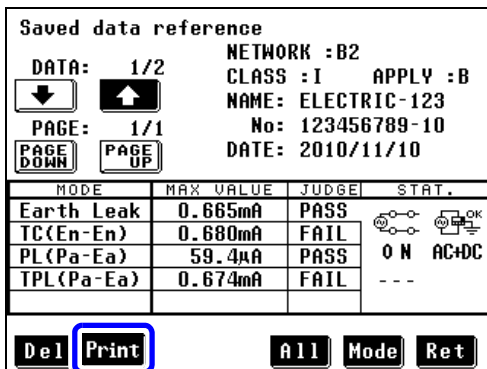

Saved measurement data reference screen

1. Display saved measurement data. (Regardless of where the Print key is pressed in a data unit, all data in the unit is printed.)
See "Checking Saved Measurement Data" (p. 104)
2. Use **↑** and **↓** to select a data unit to print.
3. Press **Print** to print the data of the selected data unit. To print data of two or more units, repeat steps 1 through 2.
4. After printing, press **Ret** to return to the system screen.

6.6 Printing Measurement Data (as required)

Print example

Date	→	Date	:2010/09/10
Equipment name	→	Name	:ELECTRIC-123
Control number	→	No.	:123456789123
Grounding class and applied part*	→	Stat	:CLASS1-B
Network	→	Network	:B2
Measurement mode	→	Mode	:TOUCH1
Filter	→	Filter	:ON
Allowable value(Upper limit)	→	Allowable(Up)	:500.0uA
Allowable value(Lower limit)	→	Allowable(Lo)	:25.0uA
Maximum value	→	Max Value	:48.24uA
Judgement result	→	Judgement	:PASS
Power supply polarity	→	Polarity	:REVERSE
Equipment under test status	→	Condition	:EARTH
Voltage applied status	→	Other Condition	:NAPPLY
		S10	:ON
		S12	:ON
		S13	:OFF

*Network B1 or B2 only

Description of printed information

Item	Explanation	Printed item	Explanation
Date	Date	(2002/09/01)	-
Name	Equipment name	(ELECTRIC-123)	-
No.	Control number	(123456789123)	-
Stat	Grounding class	CLASS1	Class-I equipment
		CLASS2	Class-II equipment
		INTERNAL	Internally powered equipment
	Applied part (Network B1, B2 only)	B	Type B applied part
		BF	Type BF applied part
		CF	Type CF applied part
Network	Network	A	Network A
		B1	Network B1
		B2	Network B2
		C	Network C
		D	Network D
		E	Network E
		F	Network F
		G	Network G

*When saved data is printed, this item is not printed.

6.6 Printing Measurement Data (as required)

Item	Explanation	Printed item	Explanation
Mode	Measurement mode	EARTH	Earth leakage current
		ENCLOSURE1	Leakage current between enclosure and earth
		ENCLOSURE2	Leakage current between enclosure and enclosure
		ENCLOSURE3	Leakage current between enclosure and line
		PAUXILIARY	Patient auxiliary current
		PATIENT1	Patient leakage current I
		PATIENT2	Patient leakage current II
		PATIENT3	Patient leakage current III
		TOUCH1	Touch current (Enclosure - Earth)
		TOUCH2	Touch current (Enclosure - Enclosure)
		TOUCH3	Touch current (Enclosure - Line)
		PATIENTP2E	Patient leakage current (Patient - Earth)
		PATIENTSIPSOP	Patient leakage current (SIP/SOP)
		PATIENTFTYPE	Patient leakage current (F-type applied part)
		PATIENTMP	Patient leakage current (Metal accessible part)
		TPATIENTP2E	Total patient leakage current (Patient - Earth)
		TPATIENTSIPSOP	Total patient leakage current (SIP/SOP)
		TPATIENTFTYPE	Total patient leakage current (F-type applied part)
		TPATIENTMP	Total patient leakage current (Metal accessible part)
		FREE	Free current
Filter	Filter	Network A	
		OFF	Network with a frequency characteristic
		ON	Multi-frequency network
		Network B1 or Network B2	
		ON	Network with a frequency characteristic
		OFF	Network with 1 k Ω non-inductive resistance only
		Network C	
		ON1_U1	Network compatible with perception/reaction (U1)
		ON1_U2	Network compatible with perception/reaction (U2)
		ON2_U1	Network compatible with abandonment (U1)
		ON2_U3	Network compatible with abandonment (U3)
		OFF	Human body impedance network
		Network D	
		OFF	Network with 1.5 k Ω // 0.15 μ F
		Network E	
		OFF	Network with 1 k Ω
		Network F	
		OFF	Network with 2 k Ω
		Network G	
		OFF	Network with damp conditions
Current	Target current	ACDC	Alternating current and direct current
		DC	Direct current
		AC	Alternating current
		ACPeak	AC peak
Upper Value	Upper limit value	1.000 mA	Upper allowable limit value*

*When saved data is printed, this item is not printed.

6.6 Printing Measurement Data (as required)

Item	Explanation	Printed item	Explanation
Lower Value	Lower limit value	50.0 μ A	Lower allowable limit value*
Max Value	Maximum value	(259.9 μ A)	–
Judgement	Judgement result	PASS	Equal to or less than the allowable value
		FAIL	Greater than the allowable value
		LOW	Equal to or less than the Lower limit value.
		---	PASS or FAIL is not determined.
Polarity	Power supply polarity	NORMAL	Positive phase
		REVERSE	Negative phase
		NONE	None
Condition	Equipment under test status	NORMAL	Normal condition
		EARTH	Single-fault condition (disconnection of protective earth conductor)
		POWERSOURCE	Single-fault condition (disconnection of one wire in power line)
		NAPPLY	Single-fault condition (110% voltage application: positive phase)
		RAPPLY	Single-fault condition (110% voltage application: negative phase)
		LLINE	Single-fault condition (line voltage application : L)
		NLINE	Single-fault condition (line voltage application : N)
Other Condition	Other test condition (Other applied voltages)	NAPPLY	Single-fault condition (Positive phase applied)
		RAPPLY	Single-fault condition (Negative phase applied)
		NONE	Single-fault condition (No application)
Special Condition	Special test condition (Specific applied voltage)	NAPPLY	Single-fault condition (Positive phase applied)
		RAPPLY	Single-fault condition (Negative phase applied)
		NONE	Single-fault condition (No application)
S10	S10 status	ON	S10 ON
		OFF	S10 OFF
S12	S12 status	ON	S12 ON
		OFF	S12 OFF
S13	S13 status	ON	S13 ON
		OFF	S13 OFF

*When saved data is printed, this item is not printed.

Instrument System Settings

Chapter 7

7

Chapter 7 Instrument System Settings

System Screen Configuration

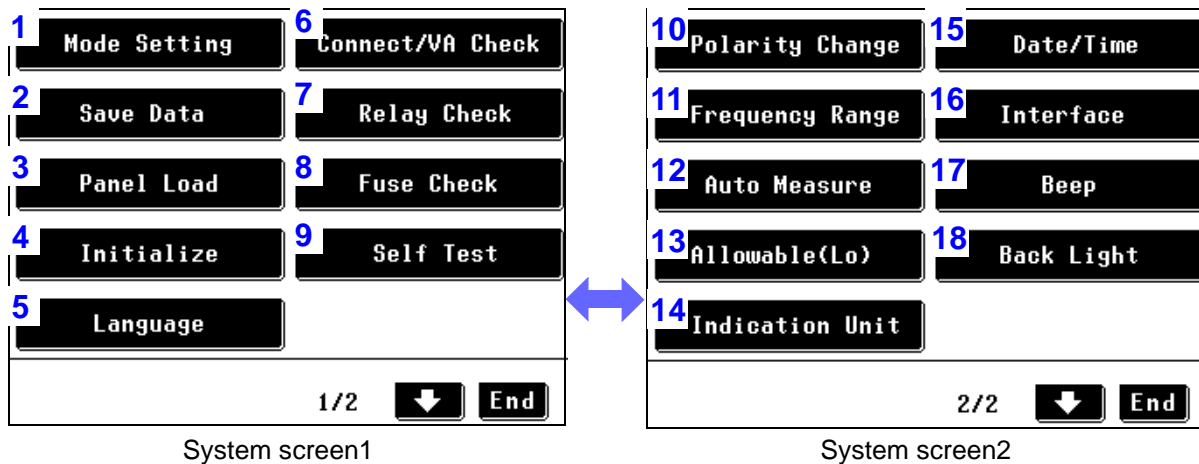

1. Mode Setting

For setting the unit of measurement data and setting the instrument for use as a voltmeter.

See (p. 117)

2. Save Data

For viewing saved measurement data.

See (p. 104)

3. Panel Load

For loading saved measurement condition data.

See (p. 120)

4. Initialize

For system initialization.

See (p. 121)

5. Language

Switches the display language between Japanese and English.

See (p. 123)

6. Connect/VA Check

For checking power line connection for measurement, input voltage measurement, and current consumption and power consumption of equipment under test.

See (p. 42)

7. Relay Check

Enables the user to check whether the network relay works normally.

See (p. 41)

8. Fuse Check

Enables the user to check whether or not the fuse is blown.

See (p. 123)

9. Self Test

For main instrument operation check.

See (p. 124)

10. Polarity Change

Enables the user to set power on polarity switching.

See (p. 126)

11. Frequency Range

Enables the user to set the frequency range. (0.1 Hz to 1M Hz, 15 Hz to 1M Hz)

See (p. 43)

12. Auto Measure

Sets the status of the instrument after completing automatic measurements.

See

13. Allowable (Lo)

Enables the user to set a lower limit value for all measurements.

See (p. 130)

14. Indication Unit

Allows the user to set the unit to be displayed.

See

15. Date/Time

For setting date and time.

See (p. 132)

16. Interface

For selecting interface and setting communication condition.

See (p. 133)

17. Beep

For ON/OFF setting of the beep sound and warning buzzer for key entry.

See (p. 135)

18. Back Light

For setting backlight constant ON/auto OFF.

See (p. 136)



Go between pages.



Returns to the initial screen.

7.1 Setting the Mode (To use the instrument as a voltmeter)

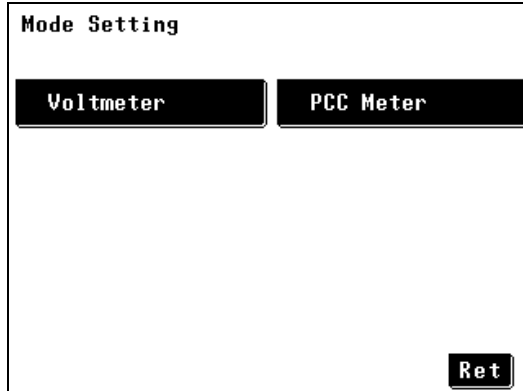

Mode setting screen

1. Press **System** on the initial screen to display the system screen.
2. Press **Mode Setting** to display the mode setting screen.
3. Select a mode.
(The leakage current tester mode is the default setting.)

7.1 Setting the Mode (To use the instrument as a voltmeter)

When **Voltmeter** mode is selected



- The maximum input voltage is DC 50 V/AC 50 Vrms. Attempting to measure voltage in excess of the maximum input could destroy the instrument and result in personal injury or death.
- Ensure that the input does not exceed the maximum input voltage or current to avoid instrument damage, short-circuiting and electric shock resulting from heat building.



- When the instrument is used as a voltmeter, it does not function as a leakage current tester.
- The auto range is not available when a 0.1 Hz frequency range setting is made. Setting the frequency range to 0.1 Hz in voltmeter mode engages the hold range (500.0 mV range).

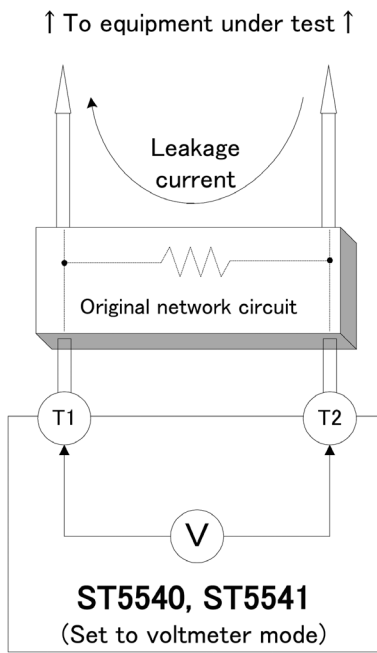

The instrument ordinarily operates as an ammeter, but the voltmeter function can be selected on the mode setting screen. By using the instrument as a voltmeter, it is possible to connect an original network if networks A through G do not conform to the required network configuration. The instrument can also be used as a general high-frequency voltmeter.

Setting to voltmeter mode results in an open internal network circuit.

The input voltage between terminals T1 and T2 can be measured.

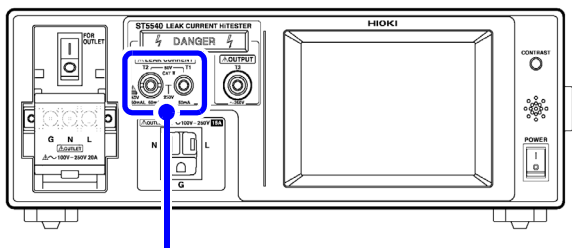

T2	Becomes a Hi terminal.
T1	Becomes a Lo terminal.

The CAL key appears when a measurement frequency from 0.1 Hz is set.

To obtain a more accurate measurement, press the CAL key once before starting measurements.

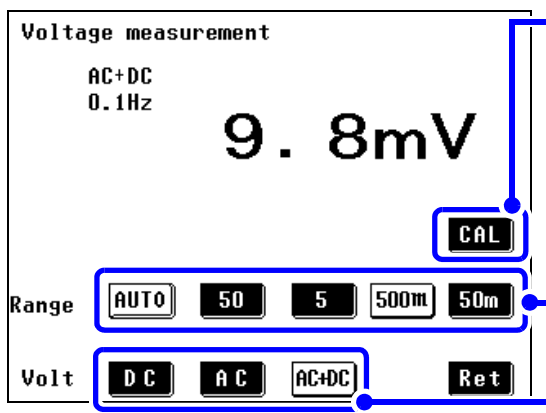

Selecting **Voltmeter** displays the voltmeter measurement screen. The voltage measurement screen starts voltmeter measurements. Measurement conditions can be changed during measurement.

Select the measurement range.

Select the target voltage.

Press **Ret** to return to the mode setting screen.



When the frequency measurement range is set to 15 Hz to 1 MHz, ACPEAK is displayed as a valid measurement voltage option.

7.1 Setting the Mode (To use the instrument as a voltmeter)

When **PCC Meter** mode is selected

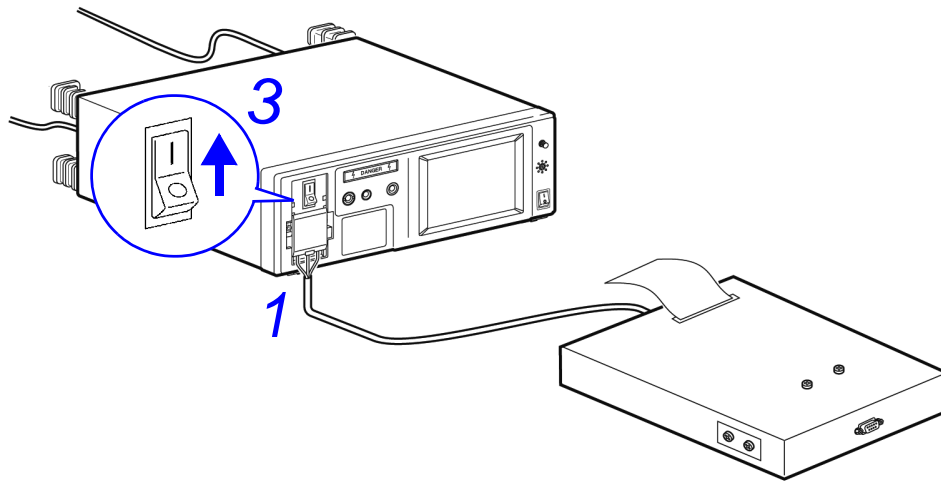

1. Connect the instrument and the equipment under test.
See "3.3 Connecting equipment under test to the instrument" (p. 36)
2. Selecting protective conductor ammeter in the mode setting screen opens the protective conductor current measurement screen.
3. Set the circuit breaker to On.
The measurement screen starts measuring protective conductor current.
Measurement conditions can be changed during measurement.
4. Press **Ret** to return to the mode setting screen.

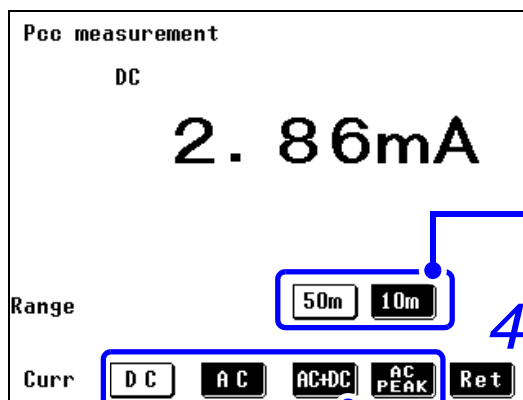

50m Sets the 50 mA range.

10m Sets the 10 mA range.

DC Sets DC current.

AC Sets AC current.

AC+DC Sets AC + DC current.

AC PEAK Sets AC current peak.

7.2 Panel Load(Loading Saved Measurement Conditions)

Measurement conditions saved by using the measurement screen can be loaded (read). The following lists the saved measurement conditions.

Measurement items/target current mode/network/measurement range/filter setting/ allowable value (normal condition, fault condition)/fault condition setting/power supply polarity/measurement class/applied part condition/equipment name/control number/measurement items for automatic measurement/measuring time/measurement delay time

1. Press **System** on the initial screen to display the system screen.
2. Press **Panel Load** to display the panel load screen.
The screen shows the keys of saved panel numbers. The protruding black keys can be selected.
Press **↑** **↓** to go between pages.

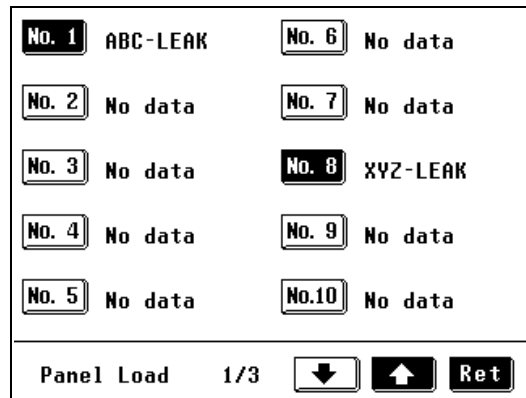

Panel load screen

3. Press a key showing the panel number to load. A confirmation screen appears.
4. Press **Yes** to load data.
The read measurement conditions are shown on the screen.
Press **No** to return to the previous screen.

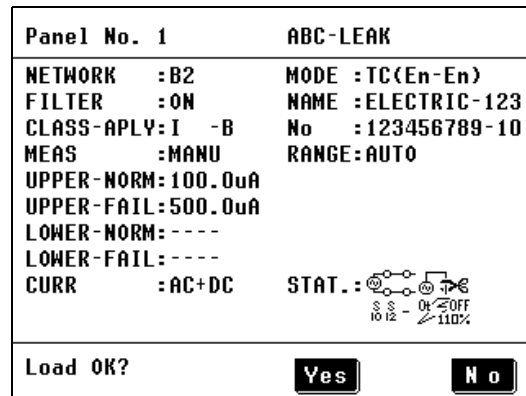

Panel load confirmation screen

NOTE

- Measurement condition data is saved in the instrument's internal SRAM. The lithium battery provides power for memory backup. When battery power becomes depleted, the saved measurement condition data in memory will be lost.
If this happens, contact our service center for a battery replacement (at a charge). The average service life of the lithium battery is about ten years.
- When the conditions for leakage current between enclosure and line, patient leakage current II, or patient leakage current III measurements are included, measurement does not have allowable values in normal condition. Therefore, the confirmation screen does not display "UPPER_NORM : (value)."

7.3 Initializing the Instrument

1. Press **System** on the initial screen to display the system screen.
2. Press **Initialize** to display the initialization screen.
3. After an initialization condition is selected, a confirmation screen appears.

1	Deletes all data including measurement conditions and measurement data. The date and time settings are not deleted.
2	Deletes all saved measurement data. Use this key when saved measurement data is no longer necessary.
3	Deletes all condition setting data including saved panels.

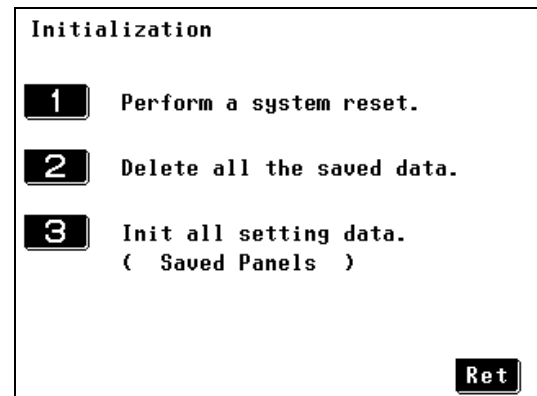

Initialization screen

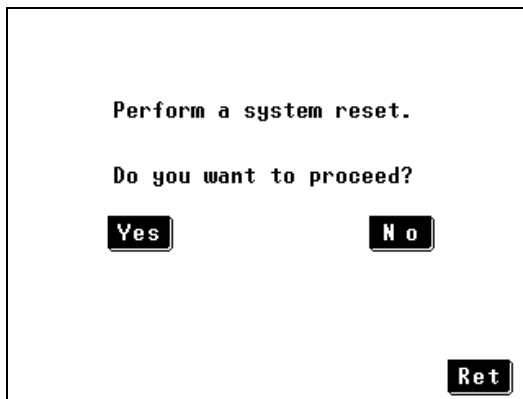
1 When "Default condition" is selected

Press **Yes** to reset the system (Perform system reset.).

The network select screen is displayed.

Press **No** to return to the initialization screen without executing system initialization.

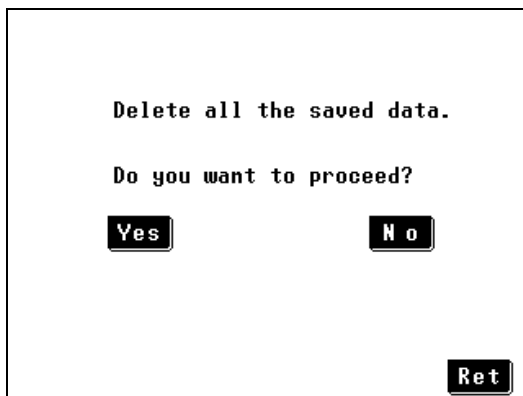
2 When "Initialization of all measurement data" is selected

Press **Yes** to delete all saved measurement data. The initialization screen is displayed.

Press **No** to return to the initialization screen without executing system initialization.

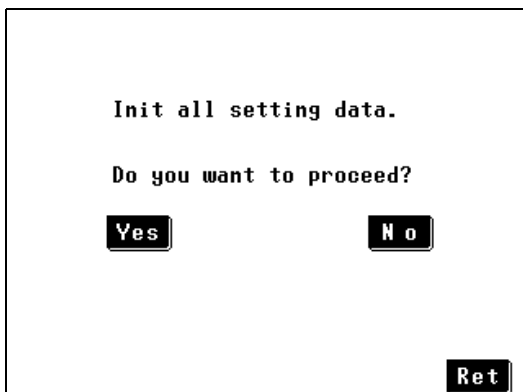
3 When "Initialization of all condition setting data (saved panels)" is selected

Press **Yes** to delete all saved test condition data including saved panels. The network select screen is displayed.

Press **No** to return to the initialization screen without executing system initialization.

7.4 Setting the Display Language

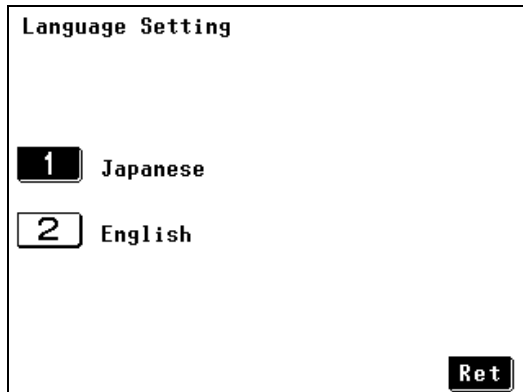

Language setting screen

1. Press **System** on the initial screen to display the system screen.
2. Press **Language** to display the language setting screen.
3. Select Japanese or English.
4. Press **Ret** to return to the system screen.

7.5 Checking Fuses(During Earth leakage current and protective conductor current measurements)

The circuits for measuring Earth leakage current and protective conductor current also contain fuses. Use the steps below to make sure that the fuses are not blown before use.

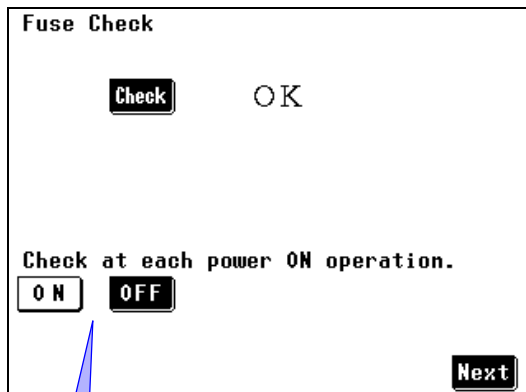

Check every time the power is turned on:

Select **ON** or **OFF** to determine whether or not this check be performed every time the power is turned on.

1. Press **System** on the initial screen to display the system screen.
2. Press **Fuse Check** to open the fuse check screen.
3. Press **Check** to start checking.
"OK" indicates that the check completed successfully.
NG indicates that the fuse for the Earth leakage current or protective conductor current detection circuit may be blown. Contact your dealer or Hioki representative.
4. Press **Ret** to return to the system screen.

NOTE

- The current detection circuits for modes other than Earth leakage current and protective conductor current measurements also contain fuses. Check such fuses in the pre-work inspection.
- Internal fuses include the power supply fuse.
Use the VA check function to check the power supply fuse.
See "Fuse inspection (when using modes other than Earth leakage current and protective conductor current modes)" (p. 42)
- Do not connect a device under test during a fuse check.
- Supply power via [LINE IN] and turn the circuit breaker On as a fuse check will otherwise not operate normally. Always confirm this before performing a fuse check.

7.6 Self-Test

1. Press **System** on the initial screen to display the system screen.
2. Press **Self Test** to display the self-test screen.
3. Select a self-test item.

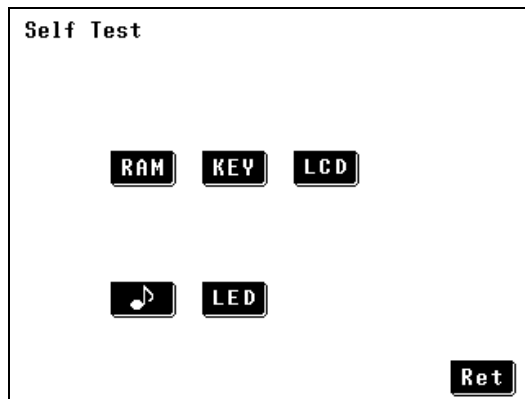

Self-test screen

RAM	Checks internal SRAM (Static RAM : read/write memory for data backup) of the HiTESTER.
KEY	Checks the keys.
LCD	Checks the LCD panel condition.
Beep	Checks the beep sound.
LED	Checks the LED lamps, warning lamp, and LCD panel backlight.

When **RAM** is selected

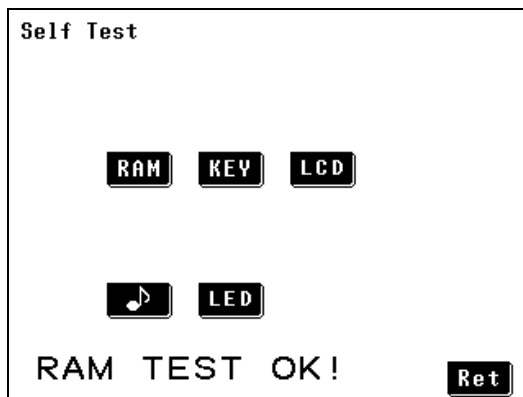

The screen shows **"RAM TEST OK!"**

Press **Ret** to return to the system screen.

If the screen shows **"RAM TEST NG!"**, the instrument is malfunctioning. Contact your dealer or Hioki representative.

When **KEY** is selected

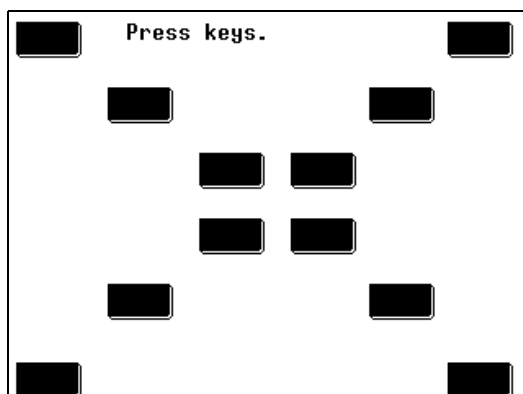

The screen shows 12 black keys. Press these keys one by one.

When a key is pressed, it turns white. When all the keys are pressed one after another, display returns to the self-test screen.

If a key does not change to white even after repeated pressing, the key may be malfunctioning. Contact your dealer or Hioki representative.

When **LCD** is selected

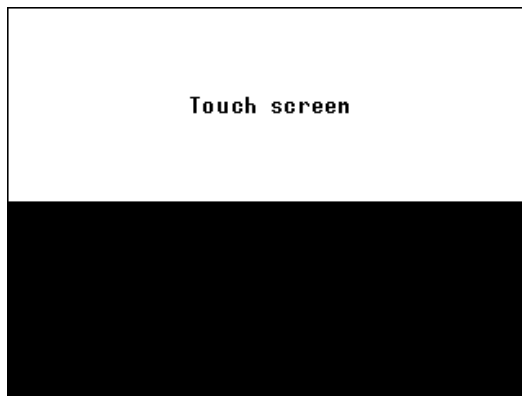



The black and white sections alternate on the screen. Check the screen for any malfunctioning dots.

If there are any malfunctioning dots, the screen is not functioning normally and you should contact your dealer or Hioki representative.

After the check, touch any location on the screen to exit test mode and return to the self-test screen.

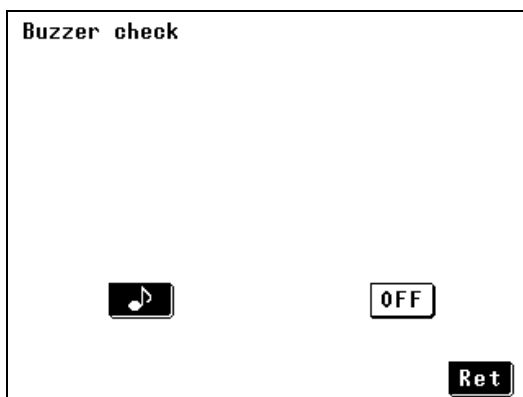
When is selected



Press  to activate the buzzer.

Press **OFF** to stop the buzzer.

If the buzzer does not sound, the instrument requires repair. Contact your dealer or Hioki representative.

Press **Ret** to return to the self-test screen.

When **LED** is selected

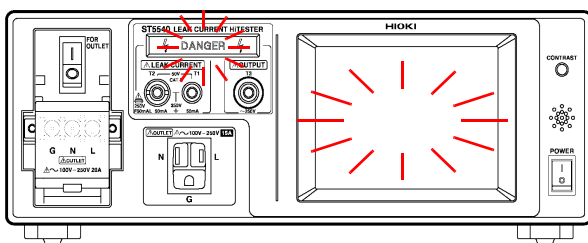

The **DANGER** lamp and the LCD backlight flash alternately. Confirm that all the lamps operate.

If any lamp does not turn on, the instrument requires repair. Contact your dealer or Hioki representative.

Press **Ret** to return to the self-test screen.

7.7 Power On Polarity Switching (to keep equipment under test on during polarity switching)



! WARNING

- When the power on polarity switching function is used, be sure not to connect the neutral wire on the secondary side of the isolation transformer to ground.
- When using an isolation transformer, be sure not to make any connections to the primary side before making connections to the secondary side. Otherwise, an electrical shock could result as voltage is output from the secondary side in some configurations.

NOTE

Power on polarity switching requires use of an isolation transformer. An error will be generated and measurements cannot start if an isolation transformer is not connected.

Connect the isolation transformer

1. Turn off the instrument and set the breaker to Off ().
2. Connect the power cord to the secondary side of the isolation transformer.
(Do not connect the neutral wire to ground when an isolation transformer is used.)
3. Connect the secondary side of the isolation transformer to [LINE IN] on the HiTESTER.
4. Connect the equipment under test to the terminal block on the front panel of the HiTESTER.
5. Connect the primary side of the isolation transformer to a commercial power supply.
6. Turn on the instrument and set the breaker to On ().
7. Set the instrument breaker to On.

Connection example

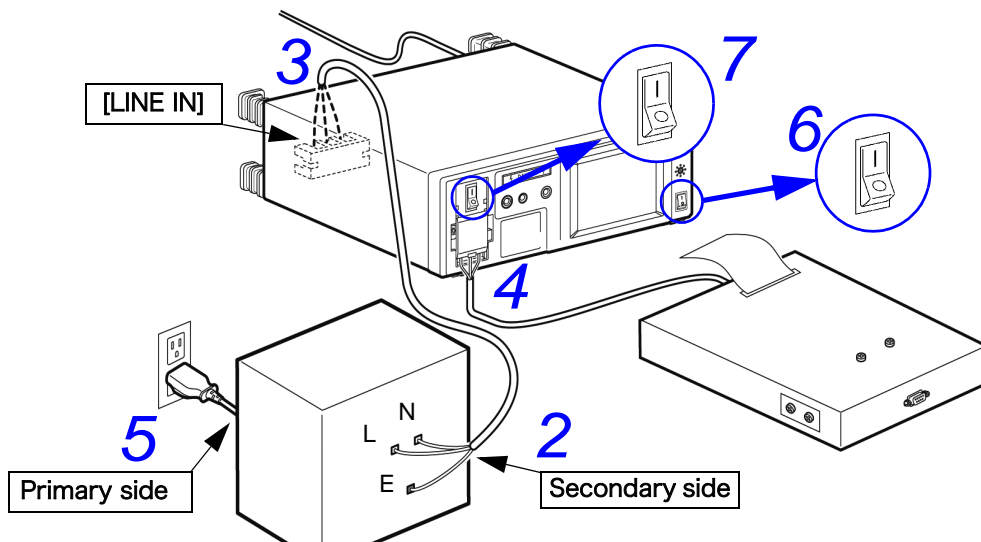

7.7 Power On Polarity Switching (to keep equipment under test on during polarity)

Setting Power On Polarity Switching

1. Check that the isolation transformer is correctly connected.
2. On the initial screen, press **System** to display the system screen.
Press **2** and set power on polarity switching to On.
3. To go directly to a leakage current test without performing relay check 2, press **Ret** to continue to tests.
To perform relay check 2, press **Check**.

"Relay check 2" (p. 128) checks relay operation by turning the LINE IN power supply line on and off.

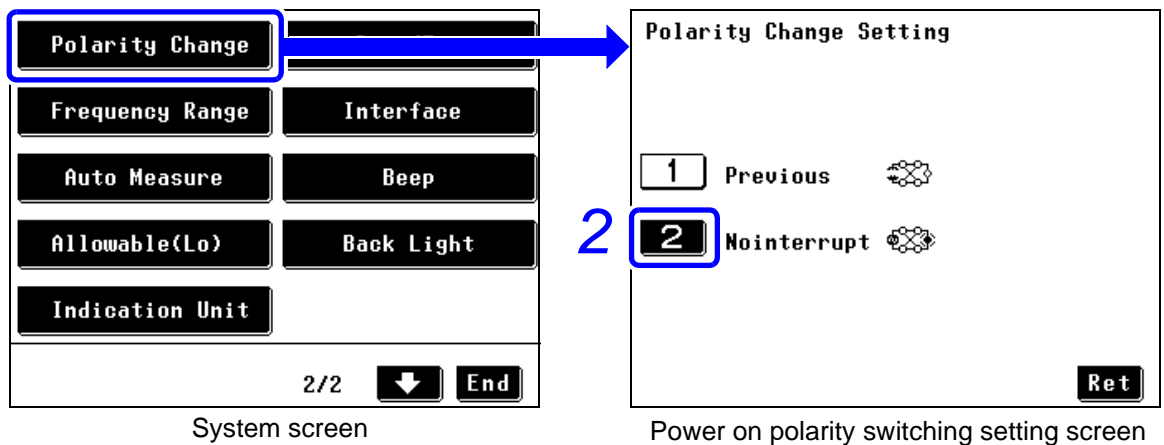

NOTE

When using power on polarity switching, a nointerrupted performance check (power on polarity switching wiring check) is performed automatically at the following times:

- When a leakage current mode is selected (during manual measurement)
- When manual operation is selected on a leakage current mode screen
- When the polarity is changed on a leakage current mode screen
- When "START" is selected on a leakage current mode screen
- During panel load operation

If NG occurs, an error screen appears, check the isolation transformer and instrument connections.

If OK, the leakage current measurement screen appears.
Start measurements.

See "6.3 Measurement examples" (p. 83)

If NG, press **Yes** to return to the leakage current mode selection screen to check connections again.

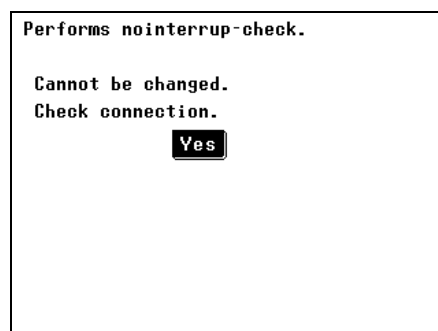

Relay check 2

**WARNING**

Do not connect the power cord to the terminal block on the rear panel. Since turning the relay On supplies power from front terminal block and the outlet, a power cord connection to the rear terminal block can cause electric shock.

NOTE

- Perform a check without connecting equipment under test.
- When the impedance value is ∞ or OVER FLOW and the relay is Off, the fuse in the instrument might have blown. Performing a fuse check may lead to recovery. (p. 123)

Required items : A device measuring impedance (for example, a tester)

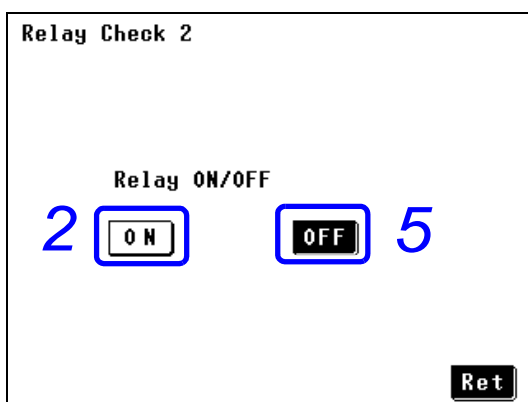

Relay check 2 ON/OFF setting screen.

1. Set the instrument circuit breaker to On.
2. Set the ON/OFF relay to **ON**.
3. Use a tester or other measuring instrument to measure the impedance value between the T1 terminal and the L terminal on the terminal block on the rear panel of this instrument.
4. Make sure that the impedance value is approximately 102 k Ω .
5. Set the ON/OFF relay to **OFF**.
6. Like step 2, use a tester or other measuring instrument to measure the impedance value between the T1 terminal and the L terminal on the terminal block on the rear panel of this instrument.
7. Make sure that the impedance value is ∞ or OVER FLOW.

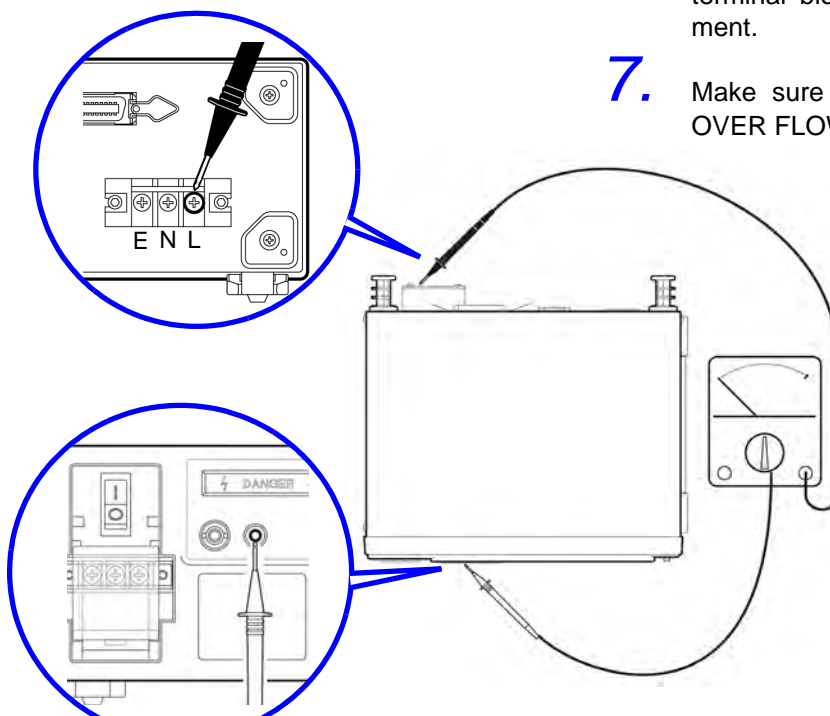

7.8 Auto Measure Setting (set instrument status)

When setting "Last Measurement State"

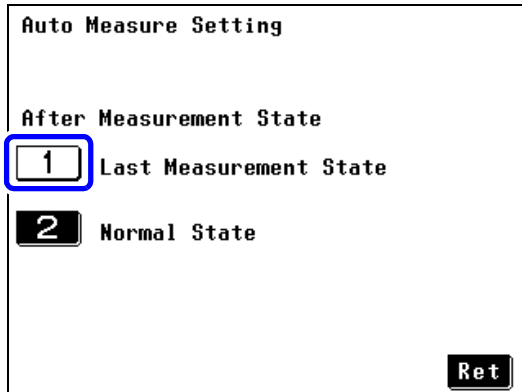

Screen for Auto Measurement Setting

When setting Auto Measure Setting is "Last Measurement State"(default), the instrument stores the final state (fault condition etc.).

Example:

If disconnection of one wire in the power cord is the final test item of the automatic measurement, no power is supplied to the device under test after the completion of an automatic measurement.

When setting "Normal State"

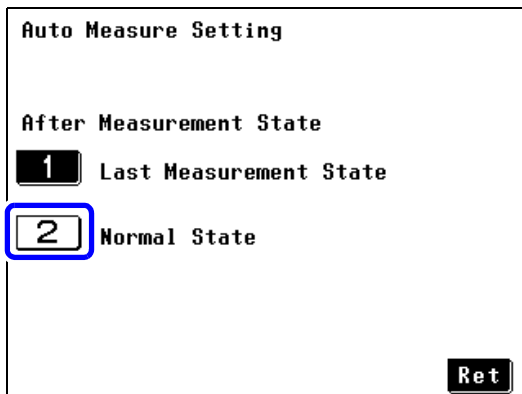

Screen for Auto Measurement Setting

When Auto Measure Setting is "Normal State", the final state (fault condition, etc.) in an automatic measurement is not stored and the device under test is automatically supplied with power. (It is returned to normal condition)

7.9 Setting Lower Limit Values (factor)

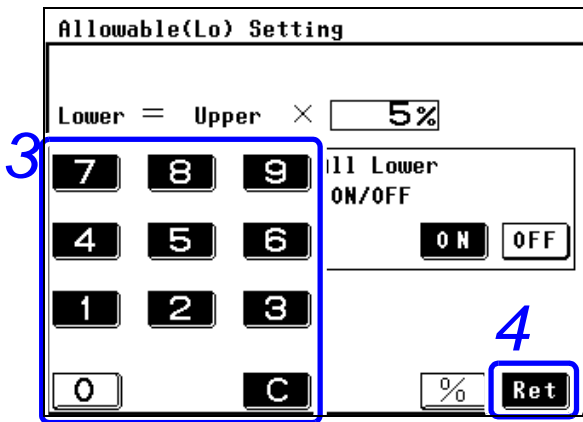

1. Press **System** on the initial screen to display the system screen.
 2. Press **Allowable(Lo)** to display the beep sound setting screen.
 3. Enter a numeric value by using numeric keys (**0** through **9**).
Measurement range
Lower limit value: 5% to 99%
- To correct an input error, press the Clear (**C**) key, then reenter the input.
4. Press **Ret** to return to the system screen.

NOTE

The lower limit value set here affects the lower limit value in all measurement modes.

It also changes lower limit values set for specific measurement modes.

Refer to "Turning lower limit values on and off for specific leakage current measurements" (p. 63) for details regarding lower limit values set in specific modes.

7.10 Setting Indication Unit

In LC Meter mode, the unit of measurement data can be set. Leakage current standards specify current criteria in "mA." When "mA" is selected, measurement values in " μ A" are converted to "mA" values for easy judgement of test results.

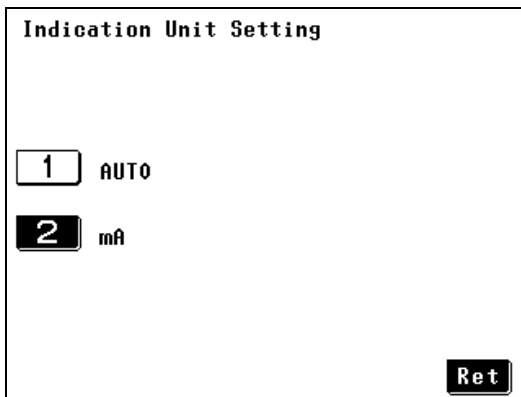

1. Select the unit of measurement data indication.

AUTO	Automatically selects the unit of measurement data according to the measurement range. (default setting).
mA	Sets the unit of measurement data to "mA" in all ranges. (Display resolution is 0.01 mA for the 50 mA range, and 0.001 mA for all other ranges.)

2. Press **Ret** to return to the system screen.

NOTE

Range of indication in all ranges when "mA" is the selected unit:

See "Ammeter mode/unit of indication : mA (HOLD) range of indication" (p. 57)

About allowable value judgement

When the unit of indication is fixed to "mA," a FAIL judgement may result even if the measurement value and allowable value are the same. This is because internally retained data contains low-order digits even if the unit is fixed to "mA," with judgement made using the values having low-order digits.

7.11 Setting Date and Time

1. Press **System** on the initial screen to display the system screen.
2. Press **Date/Time** to display the date/time setting screen.
3. Set the date and time.
From left to right, the displayed setting keys are assigned to year, month, day, hours, and minutes.
4. Press **Ret** to return to the system screen.

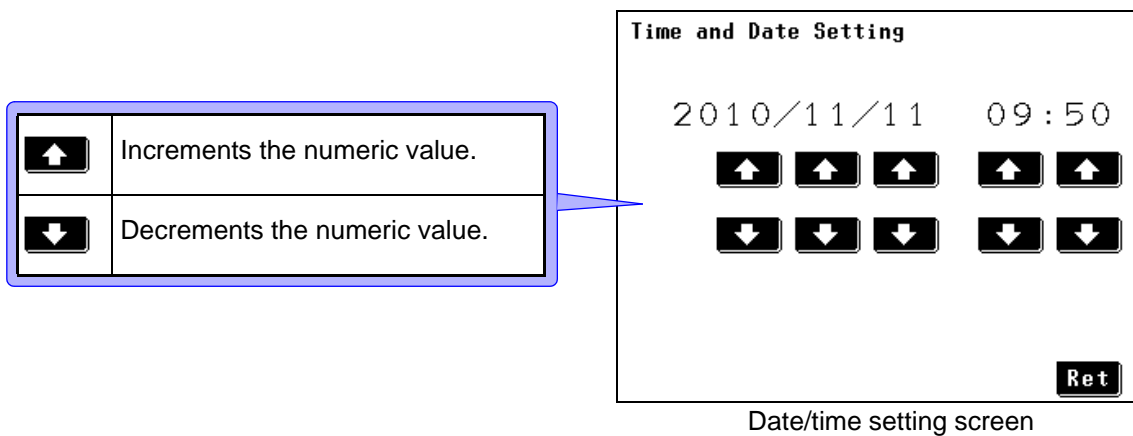

NOTE

- The entered setting becomes effective when **Ret** is pressed.
- Each key only changes the corresponding setting item; it does not change the left item.
For example, incrementing the minutes setting from 10:59 results in 10:00.
- When the date/time setting screen appears, the clock stops at the displayed time. Note that pressing **Ret** without pressing **↑** or **↓** does not make the displayed clock indication effective, but restores the original clock setting.
- The clock is accurate within about 4 minutes per month.

7.12 Interface Setting (For Communication and Printing)

1. Press **System** on the initial screen to display the system screen.
2. Press **Interface** to display the interface setting screen.
3. Select an interface.

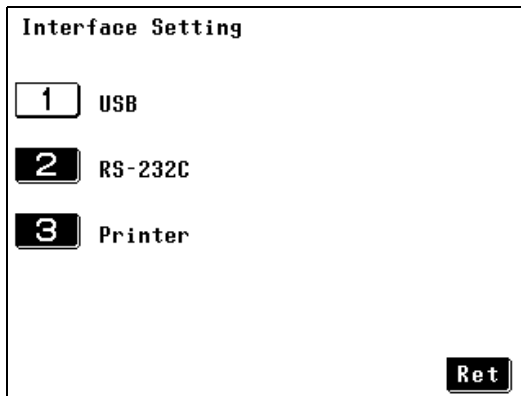

Interface setting screen

1	Sets the interface connection destination to USB.
2	Sets the interface connection destination to RS-232C.
3	Sets the interface connection destination to Printer.

NOTE

The interface is set to USB by default.

1 When "USB" is selected

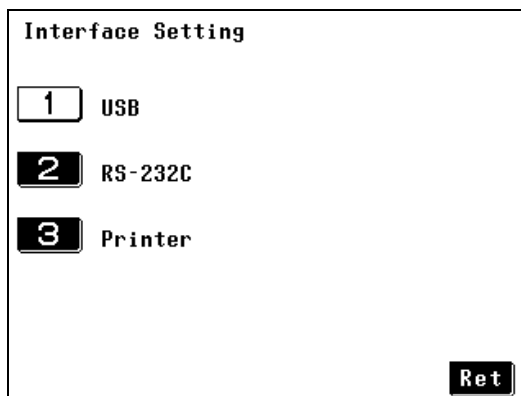

The communication condition is fixed.

See For details of the method of using the interface AF "Chapter 8 Controlling the Instrument From a Computer (RS-232C, USB interface)" (p. 139)

Press **Ret** to return to the system screen.

2 When "RS-232C" is selected

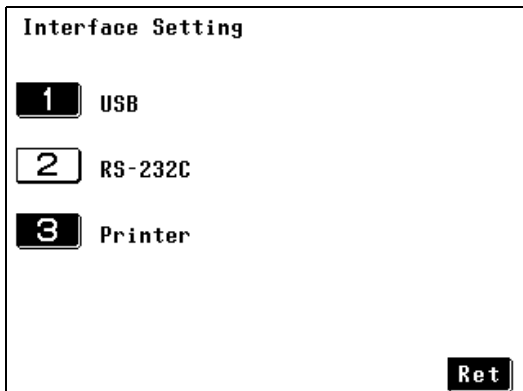

The communication condition is fixed.

For details of the method of using the interface:

See "Chapter 8 Controlling the Instrument From a Computer (RS-232C, USB interface)" (p. 139)

Press **Ret** to return to the system screen.

3 When "Printer" is selected

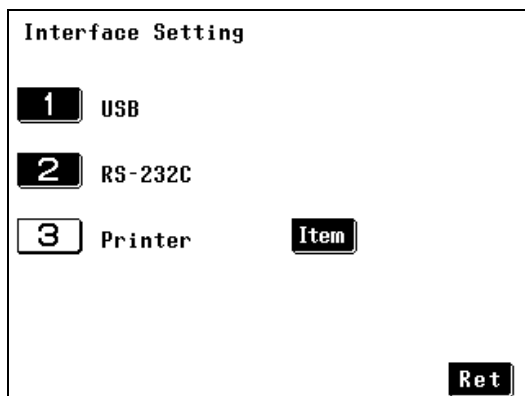

Data can be printed by connecting the optional 9442 Printer to the RS-232C port on the rear panel of the main instrument. When the printer is connected, RS-232C or USB cannot be used to communicate with a PC.

See "Setting up and connecting a printer" (p. 108)

Press **Ret** to return to the system screen.

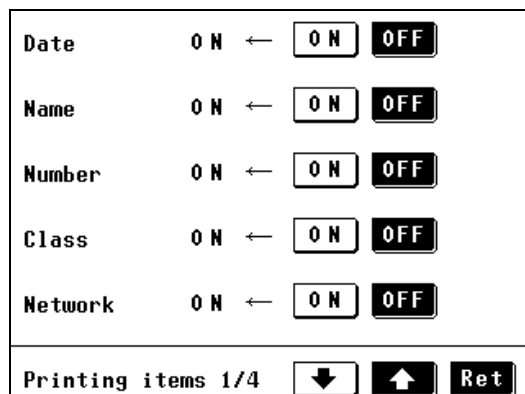

Selection of printing items

Pressing **Item** displays a list of printing items for selection.

It may not be necessary to print some items in repeated printing. In such cases, press **OFF** to cancel the printing of selected items.

To show setting items not displayed on the screen, press

PAGE UP or **PAGE DOWN**. Set each item on the screen.

NOTE

The following printing items can be set to ON or OFF.

Date of measurement, equipment name, control number, class, network, measurement mode, filter setting, target current, upper limit value, lower limit value, maximum value, judgement result, power supply polarity, and fault condition, Applied status, SW.

All items are turned ON for printing by default.

7.13 Setting the Beep Sound

1. Press **System** on the initial screen to display the system screen.
2. Press **Beep** to display the beep sound setting screen.
3. Enter beep sound settings.
4. Press **Ret** to return to the system screen.

Setting beep sound for key entry

ON	Generates a beep sound when key entry is made.
OFF	Disables the beep sound for key entry.

Beep sound setting screen

Beeper Sounds Setting

Key input **ON** **OFF**

Judgement **PASS** **FAIL** **OFF**

110% voltage output **ON** **OFF**

Output terminal T2 **ON** **OFF**

Ret

Setting beep sound for allowable value judgement

PASS	Generates a beep sound when the measurement value is within the allowable value.
FAIL	Generates a beep sound when the measurement value exceeds the allowable value.
OFF	Disables the beep sound for allowable value judgement.

Setting beep sound for voltage output at terminal T2

ON	Generates a beep sound when a dangerously high voltage is applied to terminal T2.
OFF	Disables the beep sound for a hazardous voltage warning for terminal T2.

Setting beep sound for voltage output at terminal T3 (in 110% voltage output mode)

ON	Generates a beep sound when a dangerously high voltage is applied to terminal T3.
OFF	Disables the beep sound for a hazardous voltage warning for terminal T3.

NOTE Dangerous voltage may be applied to terminal T3 only when network B is selected.

7.14 Setting the Backlight

The backlight of the LCD panel on the front panel can be set to Constant ON or Auto OFF. When a PC is connected for measurement control and the instrument display is not used, the backlight is turned off to prolong the service life of LCD parts and save energy.
(Backlight service life expectancy : Approx. 10,000 hours, as estimated by the manufacturer)

1. Press **System** on the initial screen to display the system screen.
2. Press **Back Light** to display the backlight setting screen.
3. Set the backlight control mode.

1	Keeps the backlight turned on at all times.
2	Automatically turns off the backlight after a preset time.

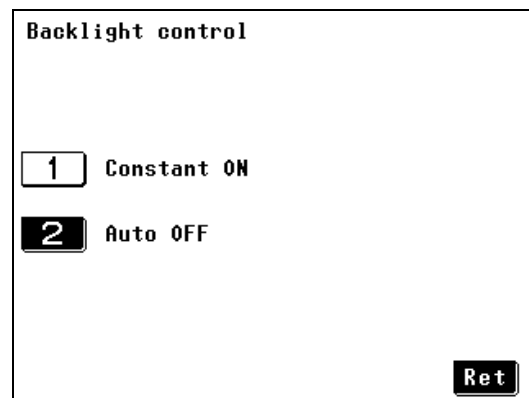

Backlight setting screen

NOTE

When the backlight control mode is set to "Auto OFF," the DANGER lamp will blink while the backlight is off.

1 When "Constant ON" is selected

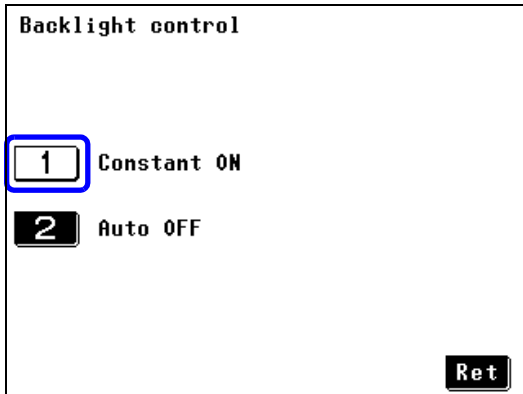

Press **Ret** to return to the system screen.

The backlight has been set to "Constant ON" by default.

2 When "Auto OFF" is selected

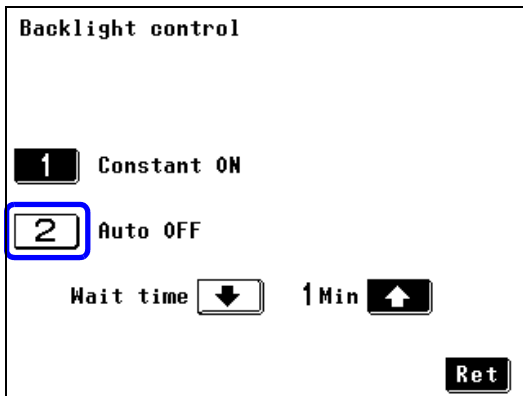

Set a desired time for the backlight auto OFF function. (1 to 30 min. (in 1 min. increments))

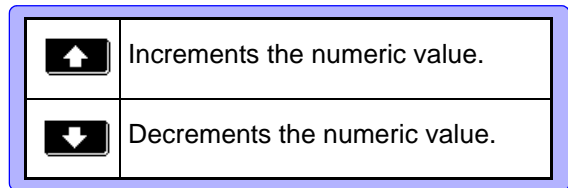

Press **Ret** to return to the system screen.

NOTE

When the preset time elapses from the last key operation, the backlight automatically turns off. The backlight turns on again when the panel surface is touched. When keys are not operated for the preset time, the backlight turns off again.

When off, the DANGER lamp will go on every few seconds to indicate that the instrument is on.

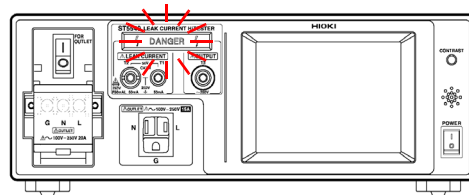

Controlling the Instrument From a Computer (RS-232C, USB interface) Chapter 8

This chapter contains information relating to the RS-232C and USB interfaces, and uses the following symbols to identify which information is relevant to each interface. Sections without these symbols pertain to both interfaces.

RS-232C : RS-232C only

USB : USB only

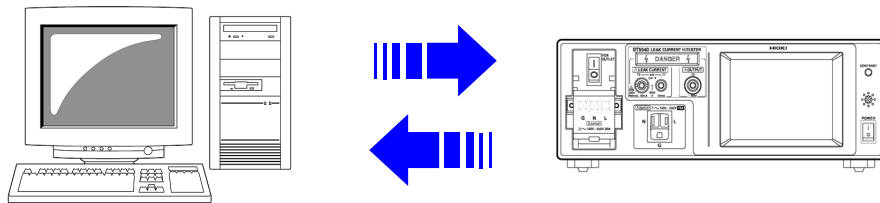

Before Use

- Always be sure to secure the RS-232C cable to the interface connector by tightening up the fixing screws.
- Be sure to input commands with data in the designated format.

The customer needs the following cable to connect the instrument.
USB CABLE: (USB B connector to USB A connector)

Overview and Features

- All functions except for the power switch and self-test functions can be controlled via RS-232C/USB.
- The instrument can be reset.

NOTE

This USB interface provides communications capability only and no storage capacity.

8.1 ST5540/ST5541 Remote Interface Overview (USB connection)

Figure 1 shows a block diagram of the ST5540/ST5541 remote interface.

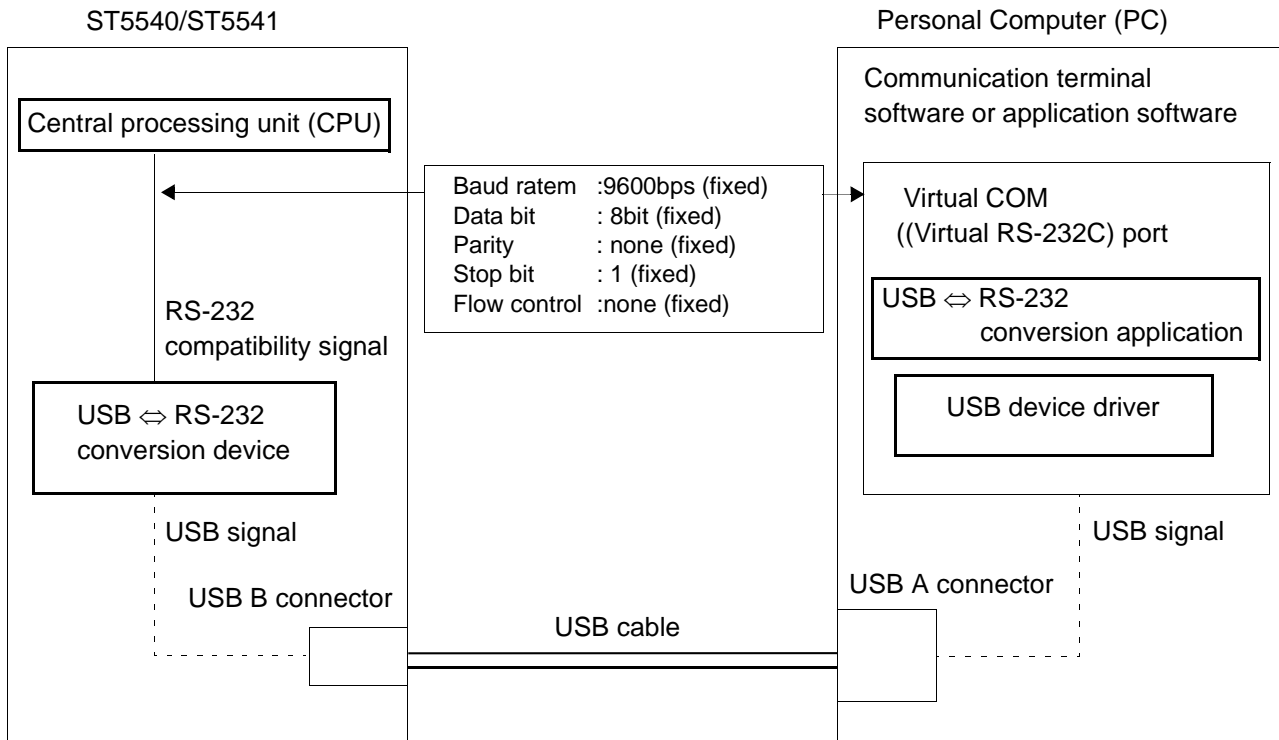
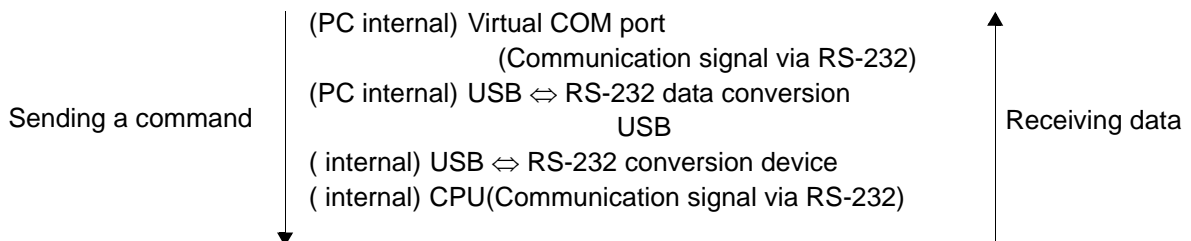

Figure 1: Overview block diagram of the remote interface

Operating principle

Communication between a personal computer and the is virtual RS-232 serial communication. While the USB interface is installed as the transmission route, actual communication uses RS-232.

It is necessary to issue RS-232 commands via the virtual COM port. When RS-232 commands are issued to the virtual COM port, commands are sent to the in the following order. (For the receipt of data, the order is reversed.)



8.2 Connect and be sure to tighten the screws on the connector



- Always turn both devices OFF when connecting and disconnecting an interface connector. Otherwise, an electric shock accident may occur.
- To avoid damage to the instrument, do not short-circuit the terminal and do not input voltage to the terminal.



Failure to fasten the connectors properly may result in sub-specification performance or damage to the equipment.

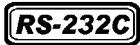

RS-232C connector

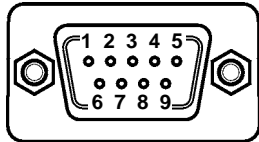

D-sub 9Pin male connector with M2.6 set screws

Connect the RS-232C cable.

To connect the HiTESTER to the controller (DTE), use a crossing cable compatible with the connectors on both the HiTESTER and the controller.

The I/O connector is designed for the terminal (DTE).
The HiTESTER uses pins Nos. 2, 3, and 5. All other pins are not used.

Pin No.	Functions		CCITT	EIA	JIS	Signal Name
			Circuit No.	Code Addr.	Code Addr.	
1	Not used					
2	Receive Data	Receive Data	104	BB	RD	RxD
3	Send Data	Send Data	103	BA	SD	TxD
4	Data Terminal Ready	Data Terminal Ready	108/2	CD	ER	DTR
5	Signal Ground	Signal Ground	102	AB	SG	GND
6	Not used					
7	Request to Send	Request to Send	105	CA	RS	RTS
8	Clear to Send	Clear to Send	106	CB	CS	CTS
9	Not used					

8.2 Connect and be sure to tighten the screws on the connector

RS-232C

When connecting the HiTESTER and PC/AT (DOS/V)

Use a crossing cable comprising two D-sub 9Pin female connectors.
Cross connection

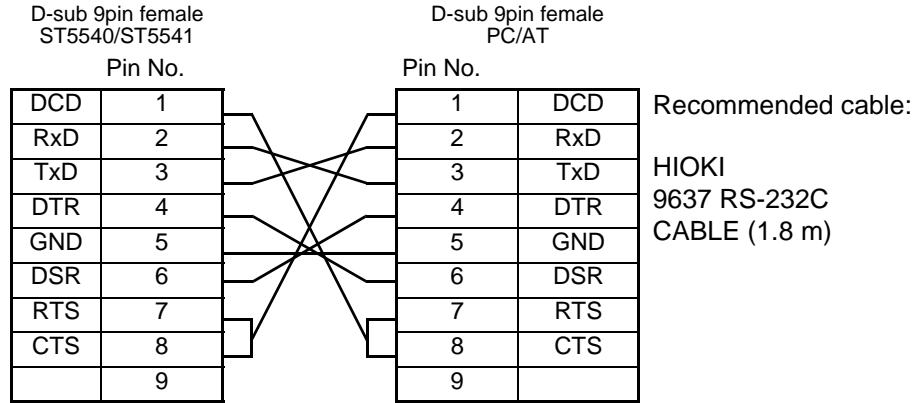

USB

Connecting a USB Cable

Install a USB driver in the PC before connecting a USB cable.
[See "Installation and operation procedures" \(p. 143\)](#)

After installing the USB driver and connecting the PC as shown in the figure, a virtual RS-232C COM port is automatically allocated to the USB port.

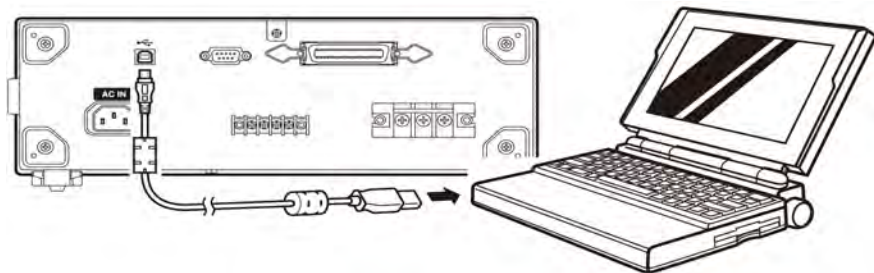

Figure 2 Connecting a cable for data communication

NOTE

RS communications cannot occur simultaneously with USB communications.
Do not connect both an RS cable and a USB cable.

8.2 Connect and be sure to tighten the screws on the connector

Installation and operation procedures

Operating environment

The instrument can be used with a personal computer that runs Windows 98 SE/ME/2000/XP/Vista and is also provided with a CD-ROM drive and USB port.

1. Make sure your computer supports the operating environment of the instrument before inserting the supplied CD-R in the CD-ROM drive.
2. Execute [Prolific_DriverInstaller.exe] on the supplied CD-ROM. Follow the instructions that appear on the screen to complete the installation.
3. Turn on the ST5540/ST5541 and connect it to the computer using an optional USB cable. A COM port is automatically assigned to the USB port.

NOTE

The COM port number assigned to the USB port depends on the computer.

Steps for confirming COM port number

1. Open Device Manager.

For Windows Vista
[Control panel] -> [System and Maintenance] -> [System] -> [Device Manager]
For Windows 2000/XP
[Control panel] -> [System] -> [Hardware] -> [Device Manager]
For Windows 98 SE/ME
[Control panel] -> [System] -> [Device Manager]
2. The X in "Prolific USB-to-Serial CommPort (COMX)" indicates the COM port number.

8.2 Connect and be sure to tighten the screws on the connector

Specifications of RS-232C

RS-232C

Transfer system	Communication : Full duplex Synchronization : Start-stop synchronization
Baud rate	9600 bps
Data length	8 bits
Parity	None
Stop bit	1 bit
Message terminator (delimiter)	Receiving data : CR+LF, CR Sending data : CR+LF
Flow control	None
Electrical characteristic	Input voltage levels 5 to 15 V :ON -15 to -5 V :OFF Output voltage levels 5 to 9 V :ON -9 to -5 V :OFF
Connector	RS-232C Interface Connector Pin Assignments (D-sub miniature 9Pin male connector with M2.6 set screws) The connector is for terminal (DTE). Recommended cable: <ul style="list-style-type: none"> • 9637 RS-232C cable (for PC/AT machines) • 9638 RS-232C cable (for PC98 series) See "8.2 Connect and be sure to tighten the screws on the connector" (p. 141)

Specifications of USB

USB

Transfer system	Communication : Full duplex Synchronization : Start-stop synchronization
Baud rate	9600 bps
Data length	8 bits
Parity	None
Stop bit	1 bit
Message terminator	Receiving data : CR+LF, CR Sending data : CR+LF
Flow control	None

8.3 Setting Communication Conditions on the HiTESTER

Setup Procedure

Refer to "7.12 Interface Setting (For Communication and Printing)" (p. 133) to perform [RS-232C] or [USB] setup.

Display screen

During communications, the instrument is in remote status and **LOCAL** is available to cancel remote status.

Press this key to return to normal status (local status).

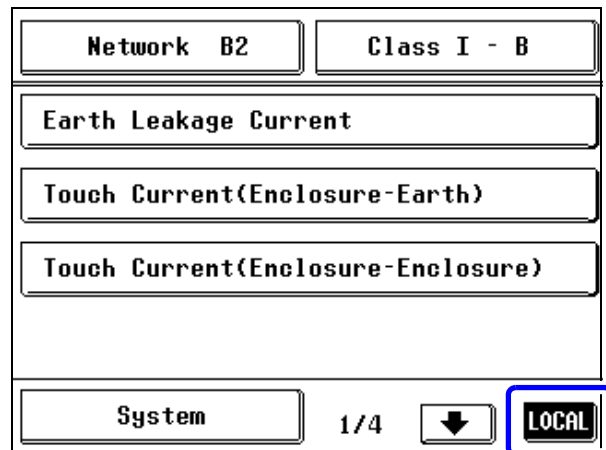

8.4 Command Message Description

Various messages are supported in order to control the HiTESTER through the interface.

Messages are divided into program messages, which are sent to the HiTESTER from the PC, and response messages, which are sent to the PC from the HiTESTER.

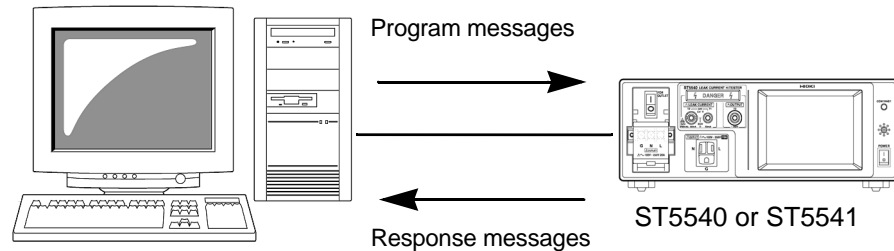

The message system has the following hierarchy.

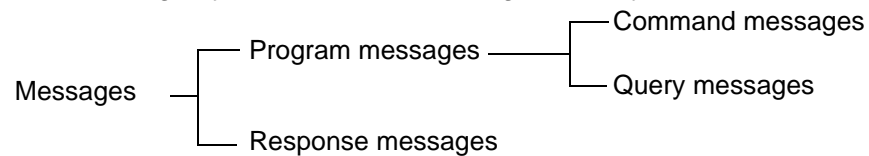

Message Format

Program Message

Program messages can be divided into either command messages or query messages.

- Command Message

Orders for controls of the instrument, such as for making measurement condition settings or for reset or the like.

Example: `:EQUIPMENT CLASS1`

↑ ↑ ↑
 Header portion Space Data portion

(command for setting the grounding class of equipment under test)

- Query Message

Orders for responses relating to results of operation, results of measurement, or the state of device settings.

Example: `:EQUIPMENT?`

↑ ↑
 Header portion Question mark

(command for querying the grounding class of equipment under test)

Response messages

After a query message has been received, a response message is produced the moment that its syntax has been checked.

Whether or not headers are prefixed to response messages is set by the "HEADer" command.

Header ON `:EQUIPMENT CLASS1`

Header OFF `CLASS1`

(grounding class of equipment under test is set to Class I)

After power-on, Header OFF is selected as a default setting.

If an error occurs when the query message is received, the query does

Command Syntax

The names of commands for the HiTESTER are as far as possible mnemonic. Furthermore, all commands have a long form, and an abbreviated short form.

In command references in this manual, the short form is written in upper case letters, and then this is continued in lower case letters so as to constitute the long form.

Either of these forms will be accepted during operation, but intermediate forms will not be accepted. Further, during operation both lower case letters and upper case letters will be accepted without distinction.

`:NETWork` OK (long form)

`:NETW` OK (short form)

`:NETWO` Error

`:NET` Error

The response messages from the instrument are returned in long form and in capital letters.

Headers

It is essential to prefix headers to program messages.

(1) Command program headers

There are three types of command : simple commands, compound commands, and standard commands.

- Simple command header

This header is a sequence of letters and digits.

`:HEADer`

- Compound command header

This header is made up from a plurality of simple command type headers marked off by colons ":"

`:CONFigure:POLarity`

- Standard command header

This header begins with an asterisk "*", and continues with a standard command stipulated by IEEE 488.2.

`*CLS`

(2) Query program headers

These are for commands used for interrogating the instrument about the results of operations, about measured values, or about the current states of settings for the instrument. As shown by the following examples, they can be recognized as queries by a question mark "?" appearing after the program header.

`:MEASure?`

`:MEASure:MAXimum?`

8.4 Command Message Description

Message Terminators

The HiTESTER supports the following message terminators.

- CR
- CR+LF

The following response message terminators can be selected depending on the interface setting.

- CR and LF
- For details of the method of setting an interface :
[See "7.12 Interface Setting \(For Communication and Printing\)" \(p. 133\)](#)

Separators

(1) Message unit separator

A semicolon ";" is used as a message unit separator when it is desired to set out several messages on a single line.

```
:NETWork A;*IDN?
```

When messages are combined in this way, if a syntax error occurs, all subsequent messages up to the next terminator will be ignored.

(2) Header separator

In a message which has a header and data, a space " " is used as the header separator to separate the header from the data.

```
:NETWork A
```

(3) Data separator

If a message has several data items, commas are required as data separators for separating these data items from one another.

```
:CONFigure:COMParator +1.000E-3,+5.000E-3
```

Data Formats

The main instrument uses character string data and decimal numeric data, and the type used varies according to the command in question.

(1) Character data

Character string data must always begin with an alphabetic character, and the following characters can be either alphabetic characters or numerals. Although in character data either upper case letters or lower case letters are accepted, response messages output by the main instrument are always in upper case letters.

:CONFigure:CONDition NORMal

(2) Decimal data

The numeric data values are all represented in decimal, in three formats identified as NR1, NR2 and NR3, and each of these can appear as either a signed number or an unsigned number. Unsigned numbers are taken as positive.

Further, if the accuracy of a numerical value exceeds the range with which the main instrument can deal, it is rounded off. (5 and above is rounded up; 4 and below is rounded down).

- NR1 integer data(examples: +12, -23, 34)
- NR2 fixed point numbers(examples: +1.23, -23.45, 3.456)
- NR3 floating point numbers(examples: +1.0E-2, -2.3E+4)

The term "NRf format" includes all these three formats.

A format is specified for each command used by the instrument.

- If data overflow occurs : **+9.999E+09**
- If data negative overflow occurs : **-9.999E+09**
- If the data displayed by the main instrument is "less than XX," the largest value that is less than the numeric value of the data is returned.

(Example)

Display: Less than 40 μ A

Data: +39.99E-06

- If the measurement value is not fixed due to Auto range mode, **+9.999E+10** will be displayed.
- When instrument data is less than 4 digits, the digit without data is returned as "0."

(Example)

"+001.0E-06" data is indicated as "_1.0 μ A."

" " is not displayed

8.4 Command Message Description

Abbreviation of Compound Commands

When several compound commands have a common head portion, for example `:CONFigure:CONDition` and `:CONFigure:POLarity`, then, when and only when writing them directly following on from one another, this common portion (`:CONFigure:` in this example) can be omitted from each command.

This common portion is called "the current path", by analogy with the general concept of the current directory in the directory structure of UNIX or MS-DOS, and until it is cleared the analysis of following commands is performed by deeming them to be preceded by the current path which has been curtailed in the interests of brevity. This manner of using the current path is shown in the following example :

Normal expression

```
:CONFigure:CONDition NORMal;:CONFigure:POLarity NORMal
```

Abbreviated expression

```
:CONFigure:CONDition NORMal;POLarity NORMal
```

↑
This becomes the current path, and can be curtailed from the following messages.

The current path is cleared when the power is turned on, when a colon ":" appears at the start of a command, and when a message terminator is detected.

Messages of standard command form can be executed without relation to the current path. Further, they have no effect upon the current path.

It is not necessary to prefix a colon ":" at the start of headers of simple commands and compound commands. However, in order to prevent confusion with abbreviated forms and mistakes in operation, it is recommended practice always to prefix ":" to headers.

On the HiTESTER, the current paths are as follows (common in RS-232C and USB).

```
:CONFigure:
:CONFigure:WTIME:
:EQUIPMENT:
:SYSTEM:
:SYSTEM:BEEPER:
```

Output Queue and Input Buffer

Output Queue

Response messages accumulate in the output queue and are read out as data and cleared by the controller. The output queue is also cleared in the following circumstances :

- When the power is turned off and turned on again.

The HiTESTER has an output queue of 1k byte capacity. If the response messages overflow this limit of 1k byte, a query error is generated, and the output queue is cleared.

Input Buffer

The HiTESTER has an input buffer of 1k byte capacity. The RS-232C and USB does not accept data in excess of 1k bytes.

NOTE

The length of a single command should be less than 1k bytes.

Event Registers

Standard event status register (SESR)

The standard event status register is an 8-bit register.

RS-232C can read this register to learn instrument status.

The standard event status register is cleared in the following situations:

- When a *CLS command is received.
- When an *ESR? query is received.
- When the instrument is powered on.

Standard event status enable register (SESR)

Bit 7	PON	Power on flag. When the power is turned on, or on recovery from a power cut, this bit is set to 1.
Bit 6		User request. Unused
Bit 5	CME	Command error. (The command to the message terminator is ignored.) When a command which has been received contains a syntactic or semantic error, this bit is set to 1. <ul style="list-style-type: none"> • There is a mistake in a program header. • The number of data parameters is wrong. • The format of the parameters is wrong. • Unsupported commands are received.
Bit 4	EXE	Execution error. When for some reason a command which has been received cannot be executed, this bit is set to 1. <ul style="list-style-type: none"> • The designated data value is outside the set range. • The designated data value is not acceptable. • Some other function is being performed
Bit 3	DDE	Device dependent error. When a command cannot be executed due to some cause other than a command error, a query error, or an execution error, this bit is set to 1. <ul style="list-style-type: none"> • Execution is impossible due to an abnormality inside the main instrument. • The result of the pre-check (to prevent ground faults) for touch current (Enclosure - Line) or leakage-current measurement between the enclosure and the line is N.G. • When abnormally terminated in automatic mode. • When polarity switching is set as power on method and a power on check ends in an error (NG)
Bit 2	QYE	Query error. (output queue is cleared) This bit is set to 1 when a query error is detected by the output queue control. <ul style="list-style-type: none"> • When the data overflows the output queue. • When data in the output queue has been lost.
Bit 1	RQC	(Communication error flag for RS-232C.)
Bit 0	OPC	Operation terminated. <ul style="list-style-type: none"> • Unused

Event status registers specific to the HiTESTER (ESR0)

An event status register has been provided to manage instrument events.

The event status registers are each 8-bit registers.

It is possible to determine the status of the instrument by reading these registers.

The data in event status register 0 is cleared under the following conditions.

- When a *CLS" command is received.
- When an :ESR0? query (for event status register 0) is received.

When the instrument is powered on.

Event Status Register 0 (ESR0)		
Bit 7		Not used
Bit 6	ERROR	Judgment Judgment fail
Bit 5	LOW	When the maximum value goes below the lower limit value
Bit 4	TEST	In automatic measurement
Bit 3	MEAS	Performing measurement under each condition
Bit 2	T-FAIL	Total failure(Automatic measurement only)
Bit 1	FAIL	Failure
Bit 0	PASS	Pass

8.5 Initialization Items

Item	Initialization method	Power on	*RST command	*CLS command
Device specific functions (ranges etc.)		×	○	×
Output queue		○	×	×
Input buffer		○	×	×
Event registers		○*1	×	○
Current path		○	×	×
Headers on/off		○	○	×

*1 Except the PON bit (bit 7).

8.6 Message Reference

NOTE

- Any typographical mistakes in the message will result in a command error.
- Asterisk (*) indicates data applies only to ST5540.

Common Messages

Messages	Explanation	Ref page
*CLS	Clears event registers and status byte registers	(p. 163)
*ESR?	Queries the event status register	(p. 163)
*IDN?	Queries the equipment ID	(p. 163)
*RST	Restores the default settings (factor settings)	(p. 164)
*TST?	Queries the self-test and result	(p. 164)

Messages Specific to the HiTESTER

Setting of the equipment under test

Messages	Explanation	Ref page
:EQUIPMENT	Sets the grounding class of equipment under test	(p. 206)
:EQUIPMENT?	Queries the grounding class of equipment under test	(p. 206)
:EQUIPMENT :IDENTITY	Sets the equipment name/control number of equipment under test	(p. 207)
:EQUIPMENT :IDENTITY?	Queries the equipment name/control number of equipment under test	(p. 207)
* :EQUIPMENT :TYPE	Sets the applied part of equipment under test (Network B1, B2 only)	(p. 207)
* :EQUIPMENT :TYPE?	Queries the applied part of equipment under test (Network B1, B2 only)	(p. 207)

Network

Messages	Explanation	Ref page
:NETWork	Sets the network	(p. 223)
:NETWork?	Queries the network	(p. 223)

Measurement mode

Messages	Explanation	Ref page
:MODE	Sets the measurement mode	(p. 221)
:MODE?	Queries the measurement mode	(p. 221)

Measurement method

Messages	Explanation	Ref page
:CONFigure:AUTO	Sets the measurement method (automatic/manual)	(p. 167)
:CONFigure:AUTO?	Queries the measurement method (automatic/manual)	(p. 167)

Measurement items

Messages	Explanation	Ref page
:APPLY	Sets the voltage application ON/OFF	(p. 165)
:APPLY?	Queries the voltage application ON/OFF	(p. 165)
:CALibration	Executes calibration	(p. 166)
:CONFigure:COMPARATOR	Sets the allowable value(upper limit)	(p. 178)
:CONFigure:COMPARATOR?	Queries the allowable value(upper limit)	(p. 178)
* :CONFigure:COMPARATOR:AC	Sets the allowable value (upper limit:when making AC measurements)	(p. 184)
* :CONFigure:COMPARATOR:AC?	Queries the allowable value (upper limit:when making AC measurements)	(p. 184)
* :CONFigure:COMPARATOR:DC	Sets the allowable value (upper limit:when making DC measurements)	(p. 185)
* :CONFigure:COMPARATOR:DC?	Queries the allowable value (upper limit:when making DC measurements)	(p. 185)
:CONFigure:COMPARATOR:LOWER	Sets the allowable value (lower limit) On/Off	(p. 186)

8.6 Message Reference

Messages	Explanation	Ref page
:CONFigure	Queries the allowable value (lower limit) On/Off	(p. 186)
:COMParator:LOWer?		
:CONFigure:COMPara- tor:LOWerAC	Sets the allowable value (lower limit: during AC measurements) On/Off.	(p. 187)
:CONFigure:COMPara- tor:LOWerAC?	Queries the allowable value (lower limit: during AC measurements) On/Off.	(p. 187)
:CONFigure:COMPara- tor:LOWerDC	Sets the allowable value (lower limit: during DC measurements) On/Off.	(p. 188)
:CONFigure:COMPara- tor:LOWerDC?	Queries the allowable value (lower limit: during DC measurements) On/Off.	(p. 188)
:CONFigure:CURRent	Sets the target current	(p. 190)
:CONFigure:CURRent?	Queries the target current	(p. 190)
:CONFigure:FILTer	Sets the measurement network filter	(p. 191)
:CONFigure:FILTer?	Queries the measurement network filter	(p. 191)
:CONFigure:RANGe	Sets the current range	(p. 197)
:CONFigure:RANGe?	Queries the current range	(p. 197)
* :CONFigure:TERMinal	Sets the patient leakage current: Patient - earth, total patient leakage current: Patient - earth mea- surement terminal.	(p. 199)
* :CONFigure:TERMi- nal?	Queries the patient leakage current: Patient - earth, total patient leakage current: Patient - earth mea- surement terminal.	(p. 202)
:LINE	Sets the application line for Touch current (Enclo- sure - Line), Enclosure - Line leakage current mea- surement	(p. 209)
:LINE?	Queries the application line for Touch current (Enclosure - Line), Enclosure - Line leakage current measurement	(p. 209)
:MAXimum:CLEar	Clears the maximum value	(p. 209)

Manual measurement

Messages	Explanation	Ref page
:CONFigure	Sets the status of equipment under test in manual measure- ment	(p. 189)
:CONDition		
:CONFigure	Queries the status of equipment under test in manual mea- surement	(p. 189)
:CONDition?		
:CONFigure	Sets the power supply polarity in manual measurement	(p. 196)
:POLarity		
:CONFigure	Queries the power supply polarity in manual measurement	(p. 196)
:POLarity?		
* :CONFigure	Other manual measurements : Sets the application of 110% of rated voltage	(p. 192)
:OTHer		

Messages	Explanation	Ref page
* :CONFigure :OTHer?	Other manual measurements : Queries the application of 110% of rated voltage	(p. 192)
* :CONFigure :SPECial	Specific manual measurements : Sets the application of 110% of rated voltage	(p. 197)
* :CONFigure :SPECial?	Specific manual measurements : Queries the application of 110% of rated voltage	(p. 197)
* :CONFigure :SWITCh	Sets the Switch	(p. 199)
* :CONFigure :SWITCh?	Queries the Switch	(p. 199)

Automatic measurement

Messages	Explanation	Ref page
:AMC?	Queries the automatic measurement completion	(p. 165)
:CONFigure :AUTO:KIND	Sets the type of automatic measurement	(p. 167)
:CONFigure :AUTO:KIND?	Queries the type of automatic measurement	(p. 167)
:CONFigure:MTIME	Sets the measuring time of automatic measurement	(p. 191)
:CONFigure:MTIME?	Queries the measuring time of automatic measurement	(p. 191)
:CONFigure :WTIME:ETC	Sets the wait time for switching operation in automatic measurement (delay c)	(p. 203)
:CONFigure:WTIME :ETC?	Queries the wait time for switching operation in automatic measurement (delay c)	(p. 203)
:CONFigure :WTIME:LINE	Sets the wait time for switching operation in automatic measurement (delay a)	(p. 204)
:CONFigure:WTIME :LINE?	Queries the wait time for switching operation in automatic measurement (delay a)	(p. 204)
:CONFigure:WTIME:POLarity	Sets the wait time for switching operation in automatic measurement (delay b2)	(p. 205)
:CONFigure:WTIME :POLarity?	Queries the wait time for switching operation in automatic measurement (delay b2)	(p. 205)
:CONFigure:WTIME :POLarity0	Sets the wait time for switching automatic measurement (delay b1)	(p. 205)
:CONFigure :WTIME:POLarity0?	Queries the wait time for switching automatic measurement (delay b1)	(p. 205)
:START	Starts automatic measurement	(p. 224)

8.6 Message Reference

Messages	Explanation	Ref page
:STOP	Stops automatic measurement	(p. 224)

Measurement data

Messages	Explanation	Ref page
:MEASure?	Queries the measurement value	(p. 210)
:MEASure:AUTO?	Queries the maximum value after automatic measurement	(p. 211)
:MEASure:MAXimum?	Queries the maximum value	(p. 213)
:MEASure:VOLTagE?	Queries the voltage measurement value	(p. 214)
:MEASure:PCC?	Queries the protective conductor current value	(p. 214)

Saved data

Messages	Explanation	Ref page
:MEMory:CLEar	Deletes the saved data	(p. 215)
:MEMory:NUMBer?	Queries the number of models in the saved data	(p. 215)
:MEMory:READ :IDENTity?	Queries the equipment name/control number of the saved data	(p. 215)
:MEMory:READ :MEASure?	Reads saved data	(p. 217)
:MEMory:SAVE:AUTO	Saves automatic measurement results	(p. 219)
:MEMory:SAVE :MAXimum	Saves the maximum value	(p. 220)

Voltmeter mode

Messages	Explanation	Ref page
:CONFigure:VOLTagE	Sets the target voltage	(p. 202)
:CONFigure:VOLTagE?	Queries the target voltage	(p. 202)
:CONFigure :VOLTagE:RANGe	Sets the voltage range	(p. 203)
:CONFigure :VOLTagE:RANGe?	Queries the voltage range	(p. 203)

Protective conductor ammeter mode

Messages	Explanation	Ref page
<code>:CONFigure:PCC</code>	Sets the measurement current (protective conductor ammeter)	(p. 195)
<code>:CONFigure:PCC?</code>	Queries the measurement current (protective conductor ammeter)	(p. 195)
<code>:CONFig-ure:PCC:RANGe</code>	Sets current range (protective conductor ammeter)	(p. 195)
<code>:CONFig-ure:PCC:RANGe?</code>	Queries current range (protective conductor ammeter)	(p. 195)

Event register

Messages	Explanation	Ref page
<code>:ESR0?</code>	Queries the event status register 0	(p. 208)

HeaderEvent register

Messages	Explanation	Ref page
<code>:HEADer</code>	Sets the response header	(p. 208)
<code>:HEADer?</code>	Queries the response header	(p. 208)

System

Messages	Explanation	Ref page
<code>:SYSTEM:BACKlight</code>	Sets the backlight automatic OFF function	(p. 225)
<code>:SYSTEM:BACKlight?</code>	Queries the backlight automatic OFF function	(p. 225)
<code>:SYSTEM:BEEPer:COMParator</code>	Queries the beep sound (Judgement of allowable value)	(p. 225)
<code>:SYSTEM:BEEPer:COMParator?</code>	Queries the beep sound (Judgement of allowable value)	(p. 225)
<code>:SYSTEM:BEEPer:KEY</code>	Sets the beep sound (Key entry)	(p. 226)
<code>:SYSTEM:BEEPer:KEY?</code>	Queries the beep sound (Key entry)	(p. 226)
<code>:SYSTEM:BEEPer:T2OUT</code>	Sets the beep sound (T2 output)	(p. 226)
<code>:SYSTEM:BEEPer:T2OUT?</code>	Queries the beep sound (T2 output)	(p. 226)
<code>:SYSTEM:BEEPer:T3OUT</code>	Sets the beep sound (T3 output)	(p. 227)
<code>:SYSTEM:BEEPer:T3OUT?</code>	Queries the beep sound (T3 output)	(p. 227)
<code>:SYSTEM:CLear</code>	Clears the panel	(p. 227)

8.6 Message Reference

Messages	Explanation	Ref page
:SYSTem:DATE	Sets the date	(p. 227)
:SYSTem:DATE?	Queries the date	(p. 227)
:SYSTem:FILE?	Queries the content of a panel	(p. 229)
:SYSTem:FILE:NAME	Sets the panel name	(p. 234)
:SYSTem:FILE:NAME?	Queries the panel name	(p. 234)
* :SYSTem:FREQuency	Sets the frequency range	(p. 234)
* :SYSTem:FREQuency?	Queries the frequency range	(p. 234)
:SYSTem:LANGUage	Sets the display language	(p. 235)
:SYSTem:LANGUage?	Queries the display language	(p. 235)
:SYSTem:LOAD	Loads a panel	(p. 235)
:SYSTem:LOWer	Sets the all allowable value (lower limit) On/Off	(p. 235)
:SYSTem:LOWer?	Queries the all allowable value (lower limit) On/Off	(p. 235)
:SYSTem:LOWer :COEFFicient	Sets the all allowable value (lower limit) coef- ficient	(p. 236)
:SYSTem:LOWer :COEFFicient?	Queries the all allowable value (lower limit) coefficient	(p. 236)
:SYSTem:MODE	Sets the mode	(p. 237)
:SYSTem:MODE?	Queries the mode	(p. 237)
:SYSTem:POLarity	Sets the polarity switching	(p. 237)
:SYSTem:POLarity?	Queries the polarity switching	(p. 237)
:SYSTem:SAVE	Saves a panel	(p. 238)
:SYSTem:RESet	Initializes the HiTESTER	(p. 238)
:SYSTem:TEST:FUSE?	Queries the fuse check	(p. 238)
:SYSTem:TEST:FUSE:START	Sets the fuse check (At power on)	(p. 239)
:SYSTem:TEST:FUSE:START?	Queries the fuse check (At power on)	(p. 239)
:SYSTem:TEST:RELAy?	Queries relay check	(p. 239)
:SYSTem:TEST:RELAy:START	Sets the relay check (At power on)	(p. 239)
:SYSTem:TEST:RELAy:START?	Queries relay check (At power on)	(p. 239)
:SYSTem:TEST:VA?	Queries the VA check	(p. 240)
:SYSTem:TEST:VA:START	Sets the VA check (At power on)	(p. 241)
:SYSTem:TEST:VA:START?	Queries the VA check (At power on)	(p. 241)

Messages	Explanation	Ref page
:SYSTem:TIME?	Queries the time	(p. 241)
:SYSTem:UNIT	Sets the unit of current measurement	(p. 242)
:SYSTem:UNIT?	Queries the unit of current measurement	(p. 242)

8.7 Command Message Description

Shows the command message that contains numerical or character parameters.

- <numerical value>: Numeric data values
 - (NR1) integer data
 - (NR2) fixed point numbers
 - (NR3) floating point numbers
 - (NRf) format that contains NR1, NR2, and NR3
- <characters>: Character string data
- <Data to be entered>

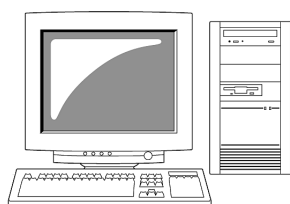
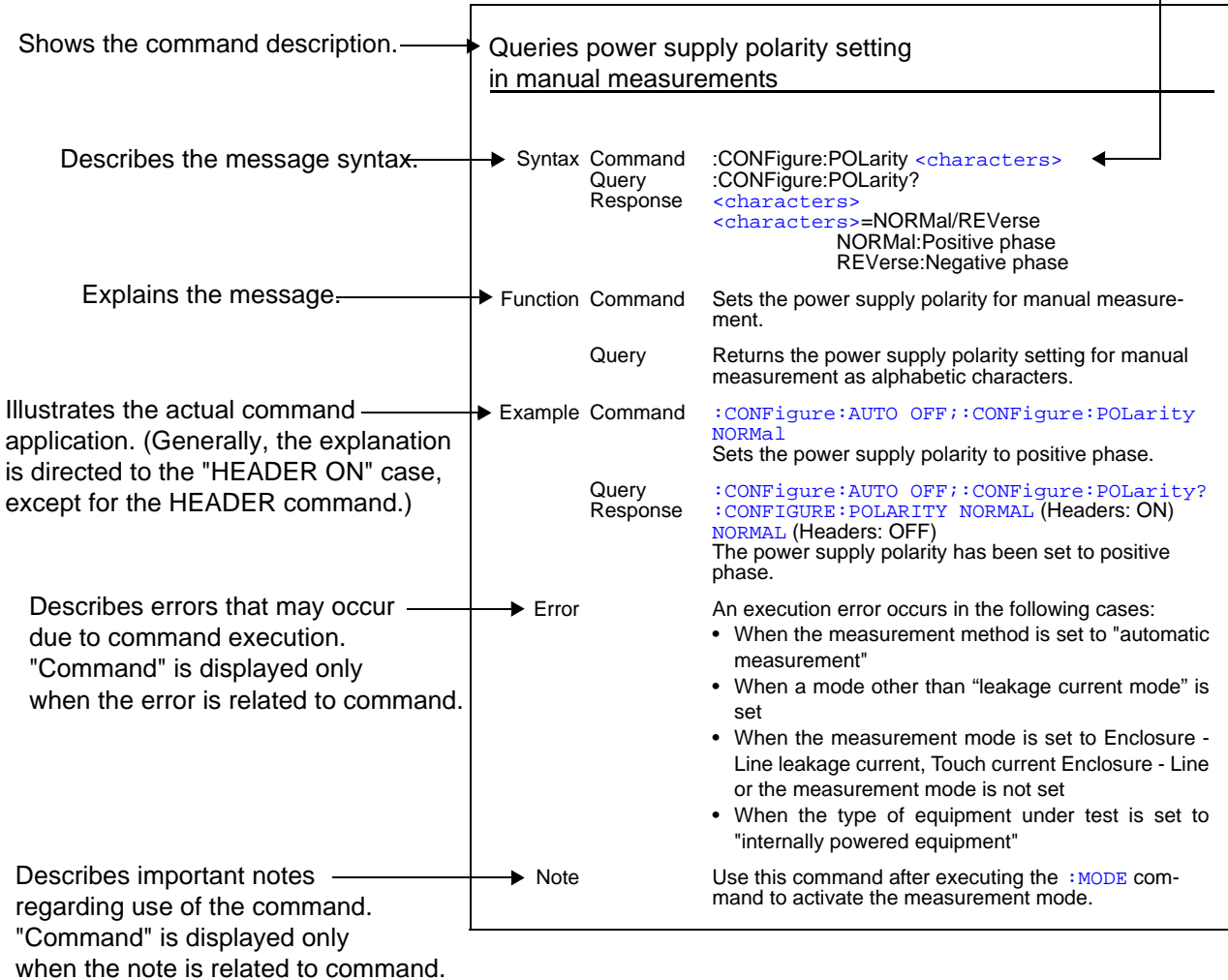

Command, Query

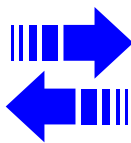

Response

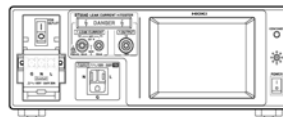

ST5540 or ST5541

Common Messages

Clears event registers and status byte registers

Syntax	Command	*CLS
Function	Command	Clears the content of event registers (SESR, ESR0) as well as the bits of the corresponding status byte registers. There is no effect on the output queue, enable registers, or bit 4 (MAV) of status byte registers.
Example	Command	*CLS
Error		Any data following a command results in a command error.

Queries the event status register

Syntax	Query	*ESR?
	Response	<numerical value> <numerical value> = 0 to 255 (NR1)
Function	Query	Returns the setting content of SESR as a numeric value, then clears the content. No header is prefixed to the response message.
Example	Query	*ESR?
	Response	32 Bit 5 of SESR has been set to 1.
Error		If the response message exceeds the output queue size, a query error occurs.

Queries the equipment ID

Syntax	Query	*IDN?
	Response	<character value 1>,<character value 2>,<character value 3>,<character value 4> <character value 1> = Manufacturer's name <character value 2> = Model name <character value 3> = 0, fixed (NR1) <character value 4> = Software versio
Function	Query	Returns the equipment manufacturer name, model name, and version of software. No header is prefixed to the response message.
Example	Query	*IDN?
	Response	HIOKI , ST5540 , 0 , V1 . 00 The equipment ID is "HIOKI, ST5540, 0, 1.00 (software version)." (The model name for ST5541 is ST5541.)
Error		If the response message exceeds the output queue size, a query error occurs.

8.7 Command Message Description

Restores the default settings (factor settings)

Syntax	Command	*RST
Function	Command	Initializes the instrument settings. The initial screen appears after initialization is completed. Same as specifying ALL with HiTESTER initialization command :SYS-Tem:RESet
Example	Command	*RST Initializes the instrument settings.
Error		Any data following a command results in a command error.
Note		The communication conditions are not initialized.

Queries the self-test and result

Syntax	Query	*TST?
	Response	<numerical value> <numerical value> = 0, 2 (NR1) 0: No error 2: RAM error
Function	Query	Conducts a self-test of main instrument and returns the result as a numeric value of 0 or 2.
Example	Query	*TST?
	Response	2 A RAM error has occurred.
Error		If the response message exceeds the output queue size, a query error occurs.
Note		A self-test initiated by a communications command is a RAM test only. The key test, LCD test, (zzz) test, and LED test on the self-test screen are not conducted by a communications command.

Specific commands

Queries the automatic measurement completion

Syntax	Query	:AMC?
	Response	<numerical value> <numerical value> = 0/1 (NR1) 0: In automatic measurement 1: Automatic measurement completed
Function	Query	Returns automatic measurement condition as a numeric value.
Example	Query	:AMC?
	Response	:AMC 1 (Headers: ON) 1 (Headers: OFF) Automatic measurement has been completed.
	Error	An execution error occurs in the following cases : <ul style="list-style-type: none"> • When the measurement method is set to "manual measurement" • When the measurement mode is not selected
Note		Use this command after executing the :MODE command to activate the measurement mode.

Sets and queries the voltage application ON/OFF

Syntax	Command	:APPLY <characters>
	Query	:APPLY?
	Response	<characters> <characters> = ON/OFF ON: Starts applying voltage. OFF: Stops applying voltage.
Function	Command	<ul style="list-style-type: none"> • When network A, C, D, E, or F is selected In manual measurement, the application of line voltage starts. • When network B1 or B2 is selected In manual measurement, the output of an application of 110% voltage starts. Single-fault condition(application of 110% of rated voltage), Other test condition (application of 110% of rated voltage), Special test condition(application of 110% of rated voltage)
	Query	Returns the voltage application condition as alphabetic characters.
Example	Command	:APPLY ON Starts the output of an application of 110% voltage. (When network B1 is selected)
	Query	:APPLY?
	Response	:APPLY ON (Headers: ON) ON (Headers: OFF) The voltage application status has been set.

8.7 Command Message Description

Sets and queries the voltage application ON/OFF

Error	<p>In Touch current : Enclosure - Line or Enclosure - Line leakage current, if the pre-check performed to prevent a ground fault results in NG judgement, an equipment-dependent error occurs.</p> <p>All situations other than 1, 2, 3, 4, and 5 result in an execution error.</p> <ol style="list-style-type: none"> 1. When the mode is set to "leakage current mode" 2. When network A, D, E, or F is selected <ul style="list-style-type: none"> Measurement modes : Enclosure - Line leakage current Measurement method : Manual measurement When application line setting is an internal contact 3. When network B1 is selected (only ST5540) <ul style="list-style-type: none"> Measurement modes : Enclosure - Earth leakage current Enclosure - Enclosure current Patient leakage current II Patient leakage current III Free current Measurement method : Manual measurement In single fault condition (application of 110% of rated voltage) 4. When networks Cor G are selected <ul style="list-style-type: none"> Measurement modes : Touch current:Enclosure - Line Measurement method : Manual measurement When application line setting is an internal contact 5. When network B2 is selected (only ST5540) <ul style="list-style-type: none"> Measurement modes : Touch current : Enclosure - Earth Touch current : Enclosure - Enclosure Patient leakage current : SIP/SOP Total patient leakage current:SIP/SOP Free current Measurement method : Manual measurement Other test condition (application of 110% of rated voltage) Measurement modes : Patient leakage current : F-type applied part Patient leakage current : Metal accessible part Total patient leakage current : F-type applied part Total patient leakage current : Metal accessible part Measurement method : Manual measurement Special test condition (application of 110% of rated voltage)
--------------	---

Executes calibration.

Syntax	Command	:CALibration
Function	Command	Executes calibration.
Example	Command	:CALibration Executes calibration.
Error		<ul style="list-style-type: none"> • An execution error occurs in the following cases : • When frequency range is set to 15 Hz • When measured current is set to something other than AC or AC + DC • When mode is "Protective conductor ammeter mode" • When mode is "Leakage current tester mode" and the following also applies <ul style="list-style-type: none"> Network other than Network B2 When measurement mode is not selected When measurement method is set to "automatic measurement"

Sets and queries the measurement method (automatic/manual)

Syntax	Command	:CONFigure:AUTO <characters>
	Query	:CONFigure:AUTO?
	Response	<characters> <characters> = ON/OFF ON : Automatic OFF : Manual
Function	Command	Sets the measurement method. When set to Auto, measurement can be started by any of the following: <ol style="list-style-type: none"> 1. Start on the measurement screen 2. START of EXIT I/O 3. :START interface command When set to Manual, the instrument performs continuous measurement.
	Query	Returns the measurement method setting as alphabetic characters.
Example	Command	:CONFigure:AUTO OFF Sets to manual measurement.
	Query	:CONFigure:AUTO?
	Response	:CONFigure:AUTO OFF (Headers: ON) OFF (Headers: OFF) Manual measurement has been set.
Error		An execution error occurs in the following cases : <ul style="list-style-type: none"> • When the measurement mode is not selected • When a mode other than "leakage current mode" is set • In automatic measurement (Command) • If automatic measurement is selected in a measurement mode in which automatic measurement cannot be selected(Command) • If automatic measurement is selected when the voltage application line is set to "external" for Touch current : Enclosure - Line or Enclosure - line leakage current (Command) • When power on polarity switching is set and a power on check ends in an error (NG), it is the instrument that is causing the error.
Note		<ul style="list-style-type: none"> • Use this command after executing the :MODE command to activate the measurement mode. • Since the settable power supply polarity and status of the equipment under test vary depending on the equipment under test settings and measurement mode, the combination for automatic measurement differs.

Queries the type and setting of automatic measurement

Syntax	Command	:CONFigure:AUTO:KIND <numerical value 1>,<numerical value 2>
	Query	:CONFigure:AUTO:KIND?
	Response	<numerical value 1>,<numerical value 2> <numerical value 1> = 1 to 4095 (NR1) <numerical value 2> = 0 to 63 (NR1)
Function	Command	Sets the type of automatic measurement. Sets the bit of the item for automatic measurement to 1. Sets other bits to 0.
	Query	Returns the automatic measurement type setting as a numeric value.

8.7 Command Message Description

Queries the type and setting of automatic measurement

Numerical value1

128 bit 7	64 bit 6	32 bit 5	16 bit 4	8 bit 3	4 bit 2	2 bit 1	1 bit 0
Not used	Negative phase	Positive phase	Single-fault condition Application of 110% voltage (Negative phase)	Single-fault condition Application of 110% voltage (Positive phase)	Single-fault condition Disconnection of protective earth conductor	Single-fault condition Disconnection of one wire in power line	Normal

32768 bit 15	16384 bit 14	8192 bit 13	4096 bit 12	2048 bit 11	1024 bit 10	512 bit 9	256 bit 8
Not used	Not used	Not used	Not used	Application of line voltage N	Application of line voltage L	AC	DC

Numerical value2

128 bit 7	64 bit 6	32 bit 5	16 bit 4	8 bit 3	4 bit 2	2 bit 1	1 bit 0
Not used	Not used	Specific 110% voltage application (Negative phase)	Specific 110% voltage application (Positive phase)	Not used	Other 110% voltage application (Negative phase)	Other 110% voltage application (Positive phase)	Other 110% voltage application (none)

32768 bit 15	16384 bit 14	8192 bit 13	4096 bit 12	2048 bit 11	1024 bit 10	512 bit 9	256 bit 8
Not used	Not used	Not used	Not used	Not used	Not used	Not used	Not used

Example

Command :**CONFIGure:AUTO:KIND 97,0**
 Sets the type of automatic measurement as follows:
 Equipment under test status: Normal condition
 Power supply polarity: Positive phase, Negative phase

Query :**CONFIGure:AUTO:KIND?**

Response :**CONFIGURE:AUTO:KIND 99,0** (Headers: ON)
99 (Headers: OFF)

The type of automatic measurement has been set as follows:
 Equipment under test status: Normal condition, Disconnection of one wire in power line
 Power supply polarity : Positive phase , Negative phase

Error

An execution error occurs in the following cases:

- When the measurement method is set to "manual measurement"
- When the measurement mode is not selected
- If the set numeric value is not within the specified range(Command)
- When a mode other than "leakage current mode" is set
- In automatic measurement(Command)

Queries the type and setting of automatic measurement

Note

- Use this command after executing the `:MODE` command to activate the measurement mode.
- Depending on the equipment under test settings and measurement mode, the settable power supply polarity and the status of equipment under test vary.
- Set unused bits (bit 7, bit 12 through bit 15 (numerical value 1), bit 6 through bit 15 (numerical value 2)) to 0.
- For network A, C, D, E, F or G automatic measurement cannot be set for internally powered equipment.
- Free current cannot be set.

When network A, D, E or F is selected

Numerical value1

Bit	Item	Explanation		
		Earth leakage current	Leakage current between enclosure and line	Enclosure - Earth leakage current Enclosure - Enclosure leakage current Free current (only network A)
bit0	Normal condition	Set at least one of bits 0 and 1 to 1. Equipment other than class I equipment cannot be set.	Set all bits to 0.	Set at least one of bits 0, 1 and 2 to 1. bit2 cannot be set for class II equipment. Devices with internal power, bit1 and bit2 cannot be set.
bit1	Single-fault condition :Disconnection of one wire in power line			
bit2	Single-fault condition :Disconnection of earth conductor in power line	Set all bits to 0.	Set all bits to 0.	Set all bits to 0.
bit3	Single-fault condition :Application of 110% voltage(Positive phase)			
bit4	Single-fault condition :Application of 110% voltage(Negative phase)			
bit5	Positive phase	Set at least one of bits 5 and 6 to 1. Devices with internal power supplies cannot be set.	Set all bits to 0.	Set at least one of bits 5 and 6 to 1. Devices with internal power supplies cannot be set.
bit6	Negative phase			
bit7	Not used	Set all bits to 0.	Set all bits to 0.	Set all bits to 0.
bit8	DC			
bit9	AC			
bit10	Application of line voltage L			
bit11	Application of line voltage N			
bit12	Not used	Set all bits to 0.	Set all bits to 0.	Set all bits to 0.
bit13				
bit14				
bit15				

8.7 Command Message Description

Numerical value2

Bit	Item	Explanation		
		Earth leakage current	Leakage current between enclosure and line	Enclosure - Earth leakage current Enclosure - Enclosure leakage current Free current (only network A)
bit0	Other test condition :Application of 110% voltage(none)	Set all bits to 0.		
bit1	Other test condition :Application of 110% voltage(Positive phase)			
bit2	Other test condition :Application of 110% voltage(Negative phase)			
bit3	Not used			
bit4	Special test condition :Application of 110% voltage(Positive phase)			
bit5	Special test condition :Application of 110% voltage(Negative phase)			
bit6	Not used			
bit7				
bit8				
bit9				
bit10				
bit11				
bit12				
bit13				
bit14				
bit15				

8.7 Command Message Description

When network C or G is selected
Numerical value1

Bit	Item	Explanation			
		Earth leakage current	Touch current : Enclosure - Line	Touch current : Enclosure - Earth Touch current : Enclosure - Enclosure	
bit0	Normal condition	Set at least one of bits 0 and 1 to 1. Equipment other than class I equipment cannot be set.	Set all bits to 0.	Set at least one of bits 0, 1 and 2 to 1. bit2 cannot be set for class II equipment. Devices with internal power, bit1 and bit2 cannot be set.	
bit1	Single-fault condition: Disconnection of one wire in power line				
bit2	Single-fault condition:Disconnection of earth conductor in power line	Set all bits to 0.			Set all bits to 0.
bit3	Single-fault condition: Application of 110% voltage(Positive phase)				
bit4	Single-fault condition:Application of 110% voltage(Negative phase)				
bit5	Positive phase	Set at least one of bits 5 and 6 to 1. Devices with internal power supplies cannot be set.			Set at least one of bits 5 and 6 to 1. Devices with internal power supplies cannot be set.
bit6	Negative phase				
bit7	Not used	Set all bits to 0.			Set at least one of bits 10 and 11 to 1. Devices with internal power supplies cannot be set.
bit8	DC				
bit9	AC				
bit10	Application of line voltage L				
bit11	Application of line voltage N				
bit12	Not used		Set all bits to 0.	Set all bits to 0.	
bit13					
bit14					
bit15					

8.7 Command Message Description

Numerical value2

Bit	Item	Explanation		
		Earth leakage current	Touch current : Enclosure - Line	Touch current : Enclosure - Earth Touch current : Enclosure - Enclosure
bit0	Other test condition :Application of 110% voltage (none)	Set all bits to 0.		
bit1	Other test condition :Application of 110% voltage (Positive phase)			
bit2	Other test condition :Application of 110% voltage (Negative phase)			
bit3	Not used			
bit4	Special test condition :Application of 110% voltage (Positive phase)			
bit5	Special test condition :Application of 110% voltage (Negative phase)			
bit6	Not used			
bit7				
bit8				
bit9				
bit10				
bit11				
bit12				
bit13				
bit14				
bit15				

When network B1 is selected
Numerical value1

Bit	Item	Explanation			
		Earth leakage current	Enclosure - Earth leakage current Enclosure - Enclosure leakage current Free current	Patient auxiliary current Patient leakage current I	Patient leakage current II Patient leakage current III
bit0	Normal condition	Set at least one of bits 0 and 1 to 1. Equipment other than class I equipment cannot be set.	Set at least one of bits 0 to 4 to 1. bit2 cannot be set for class II equipment. Devices with internal power, bit1 and bit2 cannot be set.	Set at least one of bits 0 to 2 to 1. bit2 cannot be set for class II equipment. Devices with internal power, bit1 and bit2 cannot be set.	Set all bits to 0.
bit1	Single-fault condition: Disconnection of one wire in power line				
bit2	Single-fault condition: Disconnection of earth conductor in power line	Set all bits to 0.	Set at least one of bits 5 and 6 to 1. Devices with internal power supplies cannot be set.	Set at least one of bits 5 and 6 to 1. Devices with internal power supplies cannot be set.	Set at least one of bits 3 and 4 to 1.
bit3	Single-fault condition:Application of 110% voltage (Positive phase)				
bit4	Single-fault condition:Application of 110% voltage (Negative phase)				
bit5	Positive phase	Set at least one of bits 5 and 6 to 1. Devices with internal power supplies cannot be set.	Set at least one of bits 5 and 6 to 1. Devices with internal power supplies cannot be set.	Set at least one of bits 5 and 6 to 1. Devices with internal power supplies cannot be set.	Set at least one of bits 5 and 6 to 1. Devices with internal power supplies cannot be set.
bit6	Negative phase				
bit7	Not used	Set all bits to 0.	Set all bits to 0.	Set to 0.	Set all bits to 0.
bit8	DC			Set at least one of bits 8 and 9 to 1.	
bit9	AC				
bit10	Application of line voltage L				
bit11	Application of line voltage N				
bit12	Not used				
bit13					
bit14					
bit15					

8.7 Command Message Description

Numerical value2

Bit	Item	Explanation			
		Earth leakage current	Enclosure - Earth leakage current Enclosure - Enclosure leakage current	Patient auxiliary current Patient leakage current I	Patient leakage current II Patient leakage current III
bit0	Other test condition: Application of 110% voltage(none)	Set all bits to 0.			
bit1	Other test condition: Application of 110% voltage (Positive phase)				
bit2	Other test condition: Application of 110% voltage (Negative phase)				
bit3	Not used				
bit4	Special test condition: Application of 110% voltage(Positive phase)				
bit5	Special test condition: Application of 110% voltage (Negative phase)				
bit6	Not used				
bit7					
bit8					
bit9					
bit10					
bit11					
bit12					
bit13					
bit14					
bit15					

When network B2 is selected

Numerical value1

Bit	Item	Explanation				
		1*	2*	3*	4*	5*
bit0	Normal condition	Set at least one of bits 0 and 1 to 1. Equipment other than class I equipment cannot be set.	Set at least one of bits 0 to 2 to 1. bit2 cannot be set for class II equipment. Devices with internal power, bit1 and bit2 cannot be set.			Set all bits to 0.
bit1	Single-fault condition: Disconnection of one wire in power line					
bit2	Single-fault condition: Disconnection of earth conductor in power line	Set all bits to 0.	Set all bits to 0.			Set all bits to 0.
bit3	Single-fault condition: Application of 110% voltage(Positive phase)					
bit4	Single-fault condition: Application of 110% voltage(Negative phase)					
bit5	Positive phase	Set at least one of bits 5 and 6 to 1.				
bit6	Negative phase	Devices with internal power supplies cannot be set.				

*1: Earth leakage current

*2: Touch current: Enclosure - Earth Touch current: Enclosure - Enclosure, Free current

*3: Patient auxiliary current, Patient leakage current: Patient - Earth,
Total patient leakage current: Patient - Earth

*4: Patient leakage current: SIP/SOP, Total patient leakage current: SIP/SOP

*5: Patient leakage current: F-type applied part, Patient leakage current: Metal accessible part
Total patient leakage current: F-type applied part,
Total patient leakage current: Metal accessible part

8.7 Command Message Description

Bit	Item	Explanation				
		1*	2*	3*	4*	5*
bit7	Not used	Set all bits to 0.	Set all bits to 0.	Set to 0.		Set all bits to 0.
bit8	DC			Set at least one of bits 8 and 9 to 1.		
bit9	AC					
bit10	Application of line voltage L					
bit11	Application of line voltage N					
bit12	Not used					
bit13						
bit14						
bit15						

*1: Earth leakage current

*2: Touch current: Enclosure - EarthTouch current: Enclosure - Enclosure, Free current

*3: Patient auxiliary current, Patient leakage current: Patient - Earth,
Total patient leakage current: Patient - Earth

*4: Patient leakage current: SIP/SOP, Total patient leakage current: SIP/SOP

*5: Patient leakage current: F-type applied part, Patient leakage current: Metal accessible part
Total patient leakage current: F-type applied part,
Total patient leakage current: Metal accessible part

Numerical value2

Bit	Item	Explanation							
		1*	2*	3*	4*	5*			
bit0	Other test condition :Application of 110% voltage(none)								
bit1	Other test condition :Application of 110% voltage(Positive phase)						Set at least one of bits 0, 1 and 2 to 1.	Set at least one of bits 1 and 2 to 1.	Set all bits to 0.
bit2	Other test condition :Application of 110% voltage(Negative phase)								
bit3	Not used	Set all bits to 0.		Set all bits to 0.					
bit4	Special test condition :Application of 110% voltage(Positive phase)						Set at least one of bits 4 and 5 to 1.		
bit5	Special test condition :Application of 110% voltage(Negative phase)						Set all bits to 0.	Set all bits to 0.	
bit6	Not used					Set all bits to 0.			
bit7									
bit8									
bit9									
bit10									
bit11									
bit12									
bit13									
bit14									
bit15									

*1: Earth leakage current

*2: Touch current : Enclosure - Earth, Touch current: Enclosure - Enclosure

*3: Patient auxiliary current, Patient leakage current: Patient - Earth,
Total patient leakage current: Patient - Earth

*4: Patient leakage current: SIP/SOP, Total patient leakage current: SIP/SOP

*5: Patient leakage current: F-type applied part, Patient leakage current: Metal accessible part
Total patient leakage current: F-type applied part,
Total patient leakage current: Metal accessible part

8.7 Command Message Description

Sets and queries the allowable value(upper limit)

Syntax	<p>Command :CONFigure:COMParator <numerical value 1>,<numerical value 2></p> <p>Query :CONFigure:COMParator?</p> <p>Response <numerical value 1>,<numerical value 2></p> <p><numerical value 1> = allowable valuedata (NR3) for normal condition (upper limit)</p> <p><numerical value 2> = allowable value data (NR3) for fault condition (upper limit)</p>
Function	<p>Command Sets the allowable value.(upper limit)</p> <p>The allowable value (upper allowable limit) of the instrument is value x (times) coefficient and with the interface command, the coefficient is set as 100%. The range of numeric values is from 5.000E-06 to 50.00E-03.(unit: A)</p> <p>Sets one allowable value each for normal condition and single-fault condition.(upper limit)</p> <p>The following measurement modes for the B1 and B2 networks provide an allowable value (upper limit) for AC measured current and an allowable value (upper limit) for DC.</p> <p>With patient leakage current I, patient auxiliary current, patient leakage current: patient - earth, patient leakage current: SIP/SOP, total patient leakage current: patient - earth, total patient leakage current: SIP/SOP, the allowable value for normal condition (upper limit) is set to the allowable value for normal condition (upper limit value during DC measurement) and the allowable value of normal condition (upper limit value during AC measurement) and the allowable value of a single fault condition (upper limit value) is set to the allowable value of a single fault condition (upper limit value during DC measurement) and the allowable value of a single fault condition (upper limit value during AC measurement). Zero (+0.000E+00) is set, when a either value cannot be set.</p> <p>The number of allowable values that can be set depends on grounding class, network and leakage current mode. For details, refer to (p. 180). Since allowable values cannot be set for items indicated as "0" in the table, zero (+0.000E+00) is set.</p> <ul style="list-style-type: none"> • When network A, D, E, or F is selected <ul style="list-style-type: none"> Earth leakage current, Enclosure - Earth leakage current, Enclosure - Enclosure current, Free current (only network A): <ul style="list-style-type: none"> Sets one allowable value each for normal condition and single-fault condition. Enclosure - Line leakage current: <ul style="list-style-type: none"> Sets the allowable value for normal condition to zero (+0.000E+00). Enclosure - Earth leakage current, Enclosure - Enclosure current (Internally powered equipment): <ul style="list-style-type: none"> Sets the allowable value for fault condition to zero (+0.000E+00). • When network B1 is selected(only ST5540) <ul style="list-style-type: none"> Earth leakage current, Enclosure - Earth leakage current, Enclosure - Enclosure current, Free current: <ul style="list-style-type: none"> Sets one allowable value each for normal condition and single-fault condition. Patient leakage current I, Patient auxiliary current: <ul style="list-style-type: none"> When testing normal and single fault conditions, sets two allowable values to use when making DC and AC measurements. Patient leakage current II, Patient leakage current III: <ul style="list-style-type: none"> Sets the allowable value for normal condition to zero (+0.000E+00). Patient leakage current I, Patient auxiliary current (Internally powered equipment): <ul style="list-style-type: none"> Sets the allowable value for fault condition to zero (+0.000E+00).

Sets and queries the allowable value(upper limit)

- When network C or G is selected
Earth leakage current, Touch current:Enclosure - Earth, Touch current:Enclosure - Enclosure:
Sets one allowable value each for normal condition and single-fault condition.
Touch current:Enclosure - Line:Sets the allowable value for normal condition to zero (+0.000E+00).
Touch current:Enclosure - Earth, Touch current:Enclosure - Enclosure (Internally powered equipment):
Sets the allowable value for fault condition to zero (+0.000E+00).
- When network B2 is selected(only ST5540)
Earth leakage current, Touch current:Enclosure - Earth, Touch current:Enclosure - Enclosure,
Free current:
Sets one allowable value each for normal condition and single-fault condition.
Patient auxiliary current, Patient leakage current : (Patient - Earth), Patient leakage current:SIP/SOP, Total patient leakage current:(Patient - Earth), Total patient leakage current:SIP/SOP:
When testing normal and single fault conditions, sets two allowable values to use when making DC and AC measurements.
Patient leakage current : F-type applied part, Patient leakage current : Metal accessible part, Total patient leakage current : F-type applied part, Total patient leakage current : Metal accessible part:
Sets the allowable value for normal condition to zero (+0.000E+00).

Query The number of allowable values that can be set depends on grounding class, network and leakage current mode.
For details, refer to (p. 180).
Since items indicated as "0" in the table have no settings, zero (+0.000E+00) is returned.
Returns the allowable value (upper limit) setting as four-digit numeric data in NR3 format (unit : A)
Sets one allowable value (upper limit) each for normal condition and single-fault condition.
Returns zero (+0.000E+00) when a value cannot be set.
Shared keys :
With touch current : enclosure - line, enclosure - line leakage current, it is handled as a single fault condition. With patient leakage current: F-type applied part, patient leakage current : metal accessible part, total patient leakage current : F-type applied part, total patient leakage current : metal accessible part, although this is a Special test condition, it is handled as single fault condition.

Example Command `:CONFigure:COMPARATOR +500.0E-06,+1.000E-03`
Sets the allowable value for normal condition to 500.0 mA, and the allowable value for single-fault condition to 1.000 mA.

Query `:CONFigure:COMPARATOR?`

Response `:CONFIGURE:COMPARATOR +500.0E-06,+1.000E-03` (Headers: ON)
`+500.0E-06,+1.000E-03` (Headers: OFF)
The allowable value for normal condition has been set to 500.0 mA, and the allowable value for single-fault condition has been set to 1.000 mA.

8.7 Command Message Description

Sets and queries the allowable value(upper limit)

- Error** An execution error occurs in the following cases :
- When the measurement mode is not selected
 - If the set numeric value is not within the specified range(Command)
 - When a mode other than "leakage current mode" is set
 - In automatic measurement(Command)

Note Use this command after executing the :MODE command to activate the measurement mode.

Network A, D, E, F

Leakage current mode	Item	Class I	Class II	Internally powered
Earth leakage current	Allowable value data for normal condition (upper limit)	Set value	-	
	Allowable value for fault condition (upper limit)			
Enclosure - Earth leakage current	Allowable value data for normal condition(upper limit)	Set value		Set value
	Allowable value for fault condition(upper limit)			zero
Enclosure - Enclosure leakage current	Allowable value data for normal condition(upper limit)	Set value		Set value
	Allowable value for fault condition(upper limit)			zero
Enclosure - Line leakage current	Allowable value data for normal condition(upper limit)	zero		-
	Allowable value for fault condition(upper limit)	Set value		
Free current (only network A)	Allowable value data for normal condition(upper limit)	Set value		Set value
	Allowable value for fault condition(upper limit)			zero

Network B1

Leakage current mode	Item	Class I			Class II			Internally powered		
		Type B	Type BF	Type CF	Type B	Type BF	Type CF	Type B	Type BF	Type CF
Earth leakage current	Allowable value data for normal condition(upper limit)	Set value			-			-		
	Allowable value for fault condition(upper limit)									

8.7 Command Message Description

Leakage current mode	Item	Class I			Class II			Internally powered		
		Type B	Type BF	Type CF	Type B	Type BF	Type CF	Type B	Type BF	Type CF
Enclosure - Earth leakage current	Allowable value data for normal condition(upper limit)	Set value			Set value			Set value		
	Allowable value for fault condition(upper limit)									
Enclosure - Enclosure leakage current	Allowable value data for normal condition(upper limit)	Set value			Set value			Set value		
	Allowable value for fault condition(upper limit)									
Patient leakage current I	Allowable value data for normal condition(upper limit)	Set value			Set value			zero		
	Allowable value for fault condition(upper limit)									
Patient leakage current II	Allowable value data for normal condition(upper limit)	zero	-		zero	-		zero	-	
	Allowable value for fault condition(upper limit)	Set value			Set value			Set value		
Patient leakage current III	Allowable value data for normal condition(upper limit)	-	zero		-	zero		-	zero	
	Allowable value for fault condition(upper limit)		Set value			Set value			Set value	
Patient auxiliary current	Allowable value data for normal condition(upper limit)	Set value			Set value			Set value		
	Allowable value for fault condition(upper limit)	Set value			Set value			zero		
Free current	Allowable value data for normal condition(upper limit)	Set value			Set value			Set value		
	Allowable value for fault condition(upper limit)									

Network B2

Leakage current mode	Item	Class I			Class II			Internally powered		
		Type B	Type BF	Type CF	Type B	Type BF	Type CF	Type B	Type BF	Type CF
Earth leakage current	Allowable value data for normal condition(upper limit)	Set value			-			-		
	Allowable value for fault condition(upper limit)									
Touch current (Enclosure - Earth)	Allowable value data for normal condition(upper limit)	Set value			Set value			Set value		
	Allowable value for fault condition(upper limit)							zero		
Touch current (Enclosure - Enclosure)	Allowable value data for normal condition(upper limit)	Set value			Set value			Set value		
	Allowable value for fault condition(upper limit)							zero		
Patient leakage current (Patient - Earth)	Allowable value data for normal condition(upper limit)	Set value			Set value			Set value		
	Allowable value for fault condition(upper limit)							zero		

8.7 Command Message Description

Leakage current mode	Item	Class I			Class II			Internally powered		
		Type B	Type BF	Type CF	Type B	Type BF	Type CF	Type B	Type BF	Type CF
Patient leakage current (SIP/SOP)	Allowable value data for normal condition(upper limit)	Set value			Set value			Set value		
	Allowable value for fault condition(upper limit)							zero		
Patient leakage current (F-type applied part)	Allowable value data for normal condition(upper limit)	-	zero		-	zero		-	zero	
	Allowable value for fault condition(upper limit)		Set value			Set value			Set value	
Patient leakage current (Metal accessible part)	Allowable value data for normal condition(upper limit)	zero		-	zero		-	zero		
	Allowable value for fault condition(upper limit)	Set value			Set value			Set value		
Total patient leakage current (Patient - Earth)	Allowable value data for normal condition(upper limit)	Set value			Set value			Set value		
	Allowable value for fault condition(upper limit)							zero		
Total patient leakage current (SIP/SOP)	Allowable value data for normal condition(upper limit)	Set value			Set value			Set value		
	Allowable value for fault condition(upper limit)							zero		
Total patient leakage current (F-type applied part)	Allowable value data for normal condition(upper limit)	-	zero		-	zero		-	zero	
	Allowable value for fault condition(upper limit)		Set value			Set value			Set value	
Total patient leakage current (Metal accessible part)	Allowable value data for normal condition(upper limit)	zero		-	zero		-	zero		
	Allowable value for fault condition(upper limit)	Set value			Set value			Set value		
Patient auxiliary current	Allowable value data for normal condition(upper limit)	Set value			Set value			Set value		
	Allowable value for fault condition(upper limit)							zero		
Free current	Allowable value data for normal condition(upper limit)	Set value			Set value			Set value		
	Allowable value for fault condition(upper limit)							zero		

Network C, G

Leakage current mode	Item	Class I	Class II	Internally powered
Earth leakage current	Allowable value data for normal condition(upper limit)	Set value	-	
	Allowable value for fault condition(upper limit)			
Touch current (Enclosure - Earth)	Allowable value data for normal condition(upper limit)	Set value		Set value
	Allowable value for fault condition(upper limit)			zero
Touch current (Enclosure - Enclosure)	Allowable value data for normal condition(upper limit)	Set value		Set value
	Allowable value for fault condition(upper limit)			zero
Touch current (Enclosure - Line)	Allowable value data for normal condition(upper limit)	zero		-
	Allowable value for fault condition(upper limit)	Set value		

Sets and queries the allowable value(upper limit) (when making AC measurements)(only ST5540)

Syntax	Command	<code>:CONFigure:COMParator:AC <numerical value 1>,<numerical value 2></code>
	Query	<code>:CONFigure:COMParator:AC?</code>
	Response	<code><numerical value 1>,<numerical value 2></code> <code><numerical value 1></code> = allowable value data (NR3) for normal condition (Upper limit, when AC is selected) <code><numerical value 2></code> = allowable value data (NR3) for fault condition (Upper limit, when AC is selected)
Function	Command	Sets the allowable value to use when making AC measurements.(upper limit) The instrument calculates the allowable value by multiplying the numeric value by the factor, but the factor is set to 100% by the interface command.(upper limit) The range of numeric values is from 5.000E-06 to 50.00E-03 (unit : A) Sets one allowable value each for normal condition and single-fault condition.(upper limit) The allowable value for a fault condition (upper limit) for equipment with an internal power supply is zero (+0.000E+00).
	Query	The allowable value (upper limit) for AC measurements is returned as a 4-digit NR3 format numeric value. (Unit : A) Returns one allowable value each for normal condition and single-fault condition.(upper limit) <ul style="list-style-type: none"> Internally powered equipment The allowable value of fault condition returns zero (+0.000E+00).(upper limit)
Example	Command	<code>:CONFigure:COMParator:AC +50.00E-06, +100.0E-6</code> Sets the allowable value to use when making AC measurements for normal condition to 500.0 mA, and the allowable value for single-fault condition to 1.000 mA.
	Query	<code>:CONFigure:COMParator:AC?</code>
	Response	<code>:CONFIGURE:COMPARATOR:AC +50.0E-06, +100.0E-6</code> (Headers: ON) <code>+50.00E-06,+100.0E-06</code> (Headers : OFF) The allowable value to use when making AC measurements for normal condition has been set to 500.0 mA, and the allowable value for single-fault condition has been set to 1.000 mA.
Error	An execution error occurs in the following cases: <ul style="list-style-type: none"> When the selected measurement mode is not Patient auxiliary current, Patient leakage current I, Patient leakage current (Patient - Earth), Patient leakage current (SIP/SOP), Total patient leakage current (Patient - Earth), Total patient leakage current (SIP/SOP) If the set numeric value is not within the specified range(Command) When a mode other than "leakage current mode" is set In automatic measurement (Command) 	
Note	<ul style="list-style-type: none"> Use this command after executing the <code>:MODE</code> command to activate the Patient auxiliary current, Patient leakage current I, Patient leakage current (Patient - Earth), Patient leakage current (SIP/SOP), Total patient leakage current(Patient - Earth), Total patient leakage current(SIP/SOP)mode. 	

Sets and queries the allowable value(upper limit) (when making DC measurements)(only ST5540)

Syntax	Command	<code>:CONFigure:COMParator:DC <numerical value 1>,<numerical value 2></code>
	Query	<code>:CONFigure:COMParator:DC?</code>
	Response	<code><numerical value 1>,<numerical value 2></code> <code><numerical value 1></code> = allowable value data (NR3) for normal condition (Upper limit, when DC is selected) <code><numerical value 2></code> = allowable value data (NR3) for fault condition (Upper limit, when DC is selected)
Function	Command	Sets the allowable value to use when making DC measurements. The instrument calculates the allowable value by multiplying the numeric value by the factor, but the factor is set to 100% by the interface command. The range of numeric values is from 5.000E-06 to 20.00E-03 (unit: A). The following measurement modes for the B1 and B2 networks provide an allowable value (upper limit) for AC measured current and an allowable value (upper limit) for DC. Sets one allowable value each for normal condition and single-fault condition.
	Query	Returns the allowable value setting as four-digit numeric data in NR3 format. (unit : A) Returns one allowable value each for normal condition and single-fault condition. <ul style="list-style-type: none"> Internally powered equipment The allowable value of fault condition returns zero (+0.000E+00).
Example	Command	<code>:CONFigure:COMParator:DC +50.00E-06, +100.0E-6</code> Sets the allowable value to use when making DC measurements for normal condition to 500.0 mA, and the allowable value for single-fault condition to 1.000 mA.
	Query	<code>:CONFigure:COMParator:DC?</code>
	Response	<code>:CONFIGURE:COMPARATOR:DC +50.0E-06, +100.0E-6</code> (Headers: ON) <code>+50.00E-06,+100.0E-06</code> (Headers: OFF) The allowable value to use when making DC measurements for normal condition has been set to 500.0 mA, and the allowable value for single-fault condition has been set to 1.000 mA.
Error	An execution error occurs in the following cases: <ul style="list-style-type: none"> When the selected measurement mode is not Patient auxiliary current, Patient leakage current I, Patient leakage current (Patient - Earth), Patient leakage current (SIP/SOP), Total patient leakage current (Patient - Earth), Total patient leakage current (SIP/SOP) If the set numeric value is not within the specified range (Command) When a mode other than "leakage current mode" is set In automatic measurement (Command) 	
Note	<ul style="list-style-type: none"> Use this command after executing the <code>:MODE</code> command to activate the Patient auxiliary current, Patient leakage current I, Patient leakage current (Patient - Earth), Patient leakage current (SIP/SOP), Total patient leakage current (Patient - Earth) or Total patient leakage current (SIP/SOP) mode. 	

8.7 Command Message Description

Sets and queries the allowable value (lower limit) On/Off

Syntax	<p>Command :CONFigure:COMParator:LOWer <character value 1>,<character value 2></p> <p>Query :CONFigure:COMParator:LOWer?</p> <p>Response <character value 1>,<character value 2> <character value 1> = OFF/ON OFF : Allowable value data for normal condition (lower limit)OFF ON : Allowable value data for normal condition (lower limit)ON <character value 2>= OFF/ON OFF : Allowable value for fault condition (lower limit)OFF ON : Allowable value for fault condition (lower limit)ON</p>
Function	<p>Command Sets the setting of On/Off of an allowable value (lower limit). Sets one On/Off setting of an allowable value (lower limit) each for normal and single fault conditions. The number of allowable values that can be set depends on grounding class, network and leakage current mode. For details, refer to allowable value (upper limit) settings and inquiry table. Since On/Off setting of an allowable value (lower limit) cannot be set for items indicated as 0 in the table, an Off setting is made.</p> <p>Query Returns the setting of On/Off of an allowable value (lower limit). Returns one On/Off setting of an allowable value (lower limit) for each normal condition and single fault condition. The number of allowable values that can be set depends on grounding class, network and leakage current mode. For details, refer to allowable value (upper limit) settings and inquiry table. Since items indicated as "0" in the table have no settings, Off is returned.</p>
Example	<p>Command :CONFigure:COMParator:LOWer ON,ON Sets the On/Off setting of the allowable value (lower limit) for normal condition to On and the On/Off setting of the allowable value (lower limit) for single fault condition to On.</p> <p>Query :CONFigure:COMParator:LOWer?</p> <p>Response :CONFIGURE:COMPARATOR:LOWER ON,ON (Headers: ON) ON,ON (Headers: OFF) The On/Off setting of the allowable value (lower limit) for normal condition is set to On and the On/Off setting of the allowable value (lower limit) for single fault condition is set to On.</p>
Error	<p>An execution error occurs in the following cases:</p> <ul style="list-style-type: none"> • When the measurement mode is not selected • When a mode other than "leakage current mode" is set • In automatic measurement (Command)
Note	<p>Use this command after executing the :MODE command to activate the measurement mode.</p>

Sets and queries the allowable value (lower limit) On/Off (when making AC measurements)(only ST5540)

Syntax	Command	<code>:CONFigure:COMParator:LOWerAC <character value 1>,<character value 2></code>
	Query Response	<code>:CONFigure:COMParator:LOWerAC? <character value 1>,<character value 2> <character value 1> = OFF/ON</code> OFF : Allowable value data for normal condition (lower limit : AC measurements)OFF ON : Allowable value data for normal condition (lower limit : AC measurements)ON <character value 2>= OFF/ON OFF : Allowable value for fault condition (lower limit : AC measurements)OFF ON : Allowable value for fault condition (lower limit : AC measurements)ON
Function	Command	Sets the setting of On/Off of an allowable value (lower limit: AC measurements). Sets one On/Off setting of an allowable value (lower limit: during AC measurements) each for normal and single fault conditions. For internally powered equipment, set the On/Off setting of an allowable value (lower limit : during AC measurements) for fault condition to Off.
	Query	Returns the setting of On/Off of an allowable value (lower limit: AC measurements). Returns one On/Off setting of an allowable value (lower limit : during AC measurements) for each normal and single fault conditions. Internally powered equipment Returns Off for the set of On/Off setting of the allowable value (lower limit: during AC measurements) for fault condition.
Example	Command	<code>:CONFigure:COMParator:LOWerAC ON,ON</code> Sets the On/Off setting of an allowable value (lower limit : during AC measurements) for normal condition to On and the On/Off setting of an allowable value (lower limit: during AC measurements) for single fault condition to On.
	Query Response	<code>:CONFigure:COMParator:LOWerAC?</code> <code>:CONFIGURE:COMPARATOR:LOWERAC ON,ON</code> (Headers: ON) <code>ON,ON</code> (Headers: OFF) The On/Off setting of the allowable value (lower limit) for normal condition during AC measurements is set to On and the On/Off setting of the allowable value (lower limit) for single fault condition is set to On.
Error		An execution error occurs in the following cases: <ul style="list-style-type: none"> • When patient auxiliary current, patient leakage current I, patient leakage current (patient - earth), patient leakage current (SIP/SOP), total patient leakage current (patient - earth) or total patient leakage current (SIP/SOP) measurement mode is not selected. • When a mode other than "leakage current mode" is set • In automatic measurement (Command)
Note		Use this command after using the <code>:MODE</code> command to set one of the following measurement modes: patient auxiliary current or patient leakage current I, patient leakage current (patient - earth), patient leakage current (SIP/SOP), total patient leakage current (patient - earth) or total patient leakage current (SIP/SOP).

8.7 Command Message Description

Sets and queries the allowable value (lower limit) On/Off (when making DC measurements)(only ST5540)

Syntax	Command	:CONFigure:COMParator:LOWerDC <character value 1>,<character value 2>
	Query Response	:CONFigure:COMParator:LOWerDC? <character value 1>,<character value 2> <character value 1> = OFF/ON OFF : Allowable value data for normal condition (lower limit : DC measurements)OFF ON : Allowable value data for normal condition (lower limit : DC measurements)ON <character value 2>= OFF/ON OFF : Allowable value for fault condition (lower limit : DC measurements)OFF ON : Allowable value for fault condition (lower limit : DC measurements)ON
Function	Command	Sets the setting of On/Off of an allowable value (lower limit: DC measurements). Sets one On/Off setting of an allowable value (lower limit: during DC measurements) each for normal and single fault conditions. For internally powered equipment, set the On/Off setting of an allowable value (lower limit : during DC measurements) for fault condition to Off.
	Query	Returns the setting of On/Off of an allowable value (lower limit: DC measurements). Returns the On/Off setting of an allowable value (lower limit: During DC measurements) each for normal and single fault conditions. Internally powered equipment Returns Off for the set of On/Off setting of the allowable value (lower limit : during DC measurements) for fault condition.
Example	Command	:CONFigure:COMParator:LOWerDC ON,ON Sets the On/Off setting of an allowable value (lower limit: during DC measurements) for normal condition to On and the On/Off setting of an allowable value (lower limit: during DC measurements) for single fault condition to On.
	Query Response	:CONFigure:COMParator:LOWerDC? :CONFIGURE:COMPARATOR:LOWERDC ON,ON (Headers: ON) ON,ON (Headers: OFF) The On/Off setting of the allowable value (lower limit) for normal condition during DC measurements is set to On and the On/Off setting of the allowable value (lower limit) for single fault condition is set to On.
Error		An execution error occurs in the following cases: <ul style="list-style-type: none"> • When patient auxiliary current, patient leakage current I, patient leakage current (patient - earth), patient leakage current (SIP/SOP), total patient leakage current (patient - earth) or total patient leakage current (SIP/SOP) measurement mode is not selected. • When a mode other than "leakage current mode" is set • In automatic measurement (Command)
Note		Use this command after using the :MODE command to set one of the following measurement modes: patient auxiliary current or patient leakage current I, patient leakage current (patient - earth), patient leakage current (SIP/SOP), total patient leakage current (patient - earth) or total patient leakage current (SIP/SOP).

Sets and queries the status of equipment under test in manual measurement

Syntax	<p>Command :CONFigure:CONDition <characters></p> <p>Query :CONFigure:CONDition?</p> <p>Response <characters> <characters> = NORMal/ EARTH/ POWersource/ NAPply/ RAPply/ LLINe/ NLINeNORMal: Normal condition EARTH : Single-fault condition (Disconnection of protective earth conductor) POWersource : Single-fault condition (Disconnection of one wire in power line) NAPply : Single-fault condition (Application of 110% voltage: Positive phase) RAPply : Single-fault condition (Application of 110% voltage: Negative phase) LLINe : Single-fault condition (line voltage application: L) NLINe : Single-fault condition (line voltage application: N)</p>
Function	<p>Command Sets the status of equipment under test for manual measurement.</p> <p>Query Returns the status of equipment under test for manual measurement as alphabetic characters.</p>
Example	<p>Command :CONFigure:AUTO OFF;:CONFigure:CONDition NORMal Sets the equipment under test to normal condition.</p> <p>Query :CONFigure:AUTO OFF;:CONFigure:CONDition?</p> <p>Response :CONFIGURE:CONDITION NORMAL (Headers: ON) NORMAL (Headers: OFF) The equipment under test has been set to normal condition.</p>
Error	<p>An execution error occurs in the following cases:</p> <ul style="list-style-type: none"> • When the measurement method is set to "automatic measurement" • When the measurement mode is not selected • When a mode other than "leakage current mode" is set • When the setting cannot be made in the present condition <p>For details, refer to the table in "Appendix2 List of instrument status, other test condition and special test condition" (p. A4).</p>
Note	<ul style="list-style-type: none"> • Use this command after executing the :MODE command to activate the measurement mode. • Depending on the equipment under test settings and measurement mode, the setting cannot be made in some cases. <p>For details, refer to the table in "Appendix2 List of instrument status, other test condition and special test condition" (p. A4).</p>

Sets and queries the target current

Syntax	Command :CONFigure:CURRent <characters> Query :CONFigure:CURRent? Response <characters> <characters> = ACDC/ AC/ DC/ ACPEAK ACDC : AC+DC (alternating current and direct current) AC : Alternating current DC : Direct current ACPEAK : Alternating current peak
	Network A ACDC/ AC/ DC/ACPEAK (ACPEAK is free current only) When network B1 or B2 is selected(only ST5540) ACDC/ AC/ DC/ACPEAK When network C, D, E, F or G is selected ACDC/ AC/ DC/ ACPEAK
Function	Command Sets the target current. Query Returns the target current setting as alphabetic characters.
Example	Command :CONFigure:CURRent ACDC Sets AC+DC as the target current. Query :CONFigure:CURRent? Response :CONFigure:CURRENT ACDC (Headers: ON) ACDC (Headers: OFF) The target current has been set to AC+DC.
Error	An execution error occurs in the following cases: <ul style="list-style-type: none"> • When the measurement mode is not selected • When a mode other than "leakage current mode" is set • In automatic measurement(Command) <ul style="list-style-type: none"> • When network B1 or B2 is selected (only ST5540), the measurement current that can be set will differ depending on the leakage current. See "Selectable target currents" (p. 65) • When the measurement method is set to "automatic measurement"(Command) • Setting ACPeak when the frequency range is set between 0.1 Hz to 1 MHz causes an execution error.
Note	Use this command after executing the :MODE command to activate the measurement mode.

Sets and queries the measurement network filter

Syntax	<p>Command :CONFigure:FILTER <characters></p> <p>Query :CONFigure:FILTER?</p> <p>Response <characters></p> <p><characters> = ON/ ON1_U2/ ON2_U3/ ON1_U1/ON2_U1/OFF</p> <p>When network A is selected</p> <p>OFF : Single-frequency network</p> <p>ON : Multi-frequency network</p> <p>When network B1 or B2 is selected(only ST5540)</p> <p>ON : Network with a frequency characteristic</p> <p>OFF : Network with 1 kΩ non-inductive resistance only</p> <p>When network D is selected</p> <p>ON1_U2 : Network compatible with perception/reaction U2</p> <p>ON2_U3 : Network compatible with abandonment U3</p> <p>ON1_U1 : Network compatible with perception/reaction U1</p> <p>ON2_U1 : Network compatible with abandonment U1</p> <p>OFF : Body impedance network</p> <p>When network D is selected</p> <p>OFF : 1.5 kΩ//0.15 μF network</p> <p>When network E is selected</p> <p>OFF : 1 kΩ network</p> <p>When network F is selected</p> <p>OFF : 2 kΩ network</p> <p>When network G is selected</p> <p>OFF : Network for damp conditions</p>
Function	<p>Command Sets the measurement network filter.</p> <p>Query Returns the setting of the measurement network filter as alphabetic characters.</p>
Example	<p>Command :CONFigure:FILTER OFF</p> <p>Sets the network only with 1 kΩ non-inductive resistance. (When network B2 is selected)</p> <p>Query :CONFigure:FILTER?</p> <p>Response :CONFIGURE:FILTER OFF (Headers: ON) OFF (Headers: OFF)</p> <p>The network only with 1 kΩ non-inductive resistance has been set. (When network B2 is selected)</p>
Error	<p>An execution error occurs in the following cases:</p> <ul style="list-style-type: none"> • When the measurement mode is not selected • When a mode other than "leakage current mode" is set • In automatic measurement (Command)
Note	<ul style="list-style-type: none"> • Use this command after executing the :MODE command to activate the measurement mode.

Sets and queries the measuring time of automatic measurement

Syntax	<p>Command :CONFigure:MTIME <numerical value></p> <p>Query :CONFigure:MTIME?</p> <p>Response <numerical value></p> <p><numerical value> = 1 to 300 (NR1)</p>
Function	<p>Command Sets the measuring time of automatic measurement.</p> <p>Query Returns the measuring time of automatic measurement as a numeric value.</p>

8.7 Command Message Description

Sets and queries the measuring time of automatic measurement

Example	<p>Command :CONFIGURE:MTIME 5 Sets the measuring time of automatic measurement to 5 seconds.</p> <p>Query :CONFigure:MTIME?</p> <p>Response :CONFIGURE:MTIME 5 (Headers: ON) 5 (Headers: OFF) The measuring time of automatic measurement has been set to 5 seconds.</p>
Error	<p>An execution error occurs in the following cases:</p> <ul style="list-style-type: none"> • When the measurement method is set to "manual measurement" • When the measurement mode is not selected • When a mode other than "leakage current mode" is set • In automatic measurement(Command)
Note	<ul style="list-style-type: none"> • Use this command after executing the :MODE command to activate the measurement mode. • The unit is [s]. Fractions are rounded up when 0.5 or greater and rounded off when less than 0.5.

Other manual measurements: Sets and queries the application of 110% of rated voltage(only ST5540)

Syntax	<p>Command :CONFigure:OTHer <characters></p> <p>Query :CONFigure:OTHer?</p> <p>Response <characters> <characters> = OFF/NAPPLY/RAPPLY OFF : Application of 110% voltage : none NAPPLY : Application of 110% voltage : Positive phase RAPPLY : Application of 110% voltage : Negative phase</p>
Function	<p>Command Other manual measurements: Sets application of 110% of rated voltage.</p> <p>Query Other manual measurements: Returns application of 110% of rated voltage.</p>
Example	<p>Command :CONFigure:AUTO OFF;;CONFigure:OTHer NAPPLY Other manual measurements: Sets application of 110% of rated voltage to positive phase.</p> <p>Query :CONFigure:AUTO OFF;;CONFigure:OTHer?</p> <p>Response :CONFIGURE:OTHER NAPPLY (Headers: ON) NAPPLY (Headers: OFF) Other manual measurements : Application of 110% of rated voltage has been set to positive phase.</p>
Error	<p>An execution error occurs in the following cases:</p> <ul style="list-style-type: none"> • When the measurement method is set to "automatic measurement" • When a mode other than "leakage current mode" is set • When a Network other than "B1" or "B2" is set • When the measurement mode is not set to Touch current : Enclosure - Earth, Touch current:Enclosure - Enclosure, Patient leakage current:SIP/SOP, Total patient leakage current : SIP/SOP, Free current

Other manual measurements: Sets and queries the application of 110% of rated voltage(only ST5540)**Note**

- Use this command after executing the `:MODE` command to activate the measurement mode.
- Use this command after using the `:NETWork` command to enter the B1 or B2 network.
- Use this command after executing the `:MODE` command to activate Touch current : Enclosure - Earth, Touch current : Enclosure - Enclosure, Patient leakage current:SIP/SOP, Total patient leakage current : SIP/SOP, Free current.

8.7 Command Message Description

When network B2 is selected

Measurement mode	Class-I equipment			Class-II equipment			Internally powered equipment		
	Other test condition (Other applied voltages)								
	Applica- tion of 110% voltage: none	Applica- tion of 110% volt- age:Po sitive phase	Applica- tion of 110% volt- age:Ne gative phase	Applica- tion of 110% voltage: none	Applica- tion of 110% volt- age:Po sitive phase	Applica- tion of 110% volt- age:Ne gative phase	Applica- tion of 110% voltage: none	Applica- tion of 110% volt- age:Po sitive phase	Applica- tion of 110% volt- age:Ne gative phase
Earth leakage current	-	-	-	-	-	-	-	-	-
Touch current : Enclosure - Earth	○	○	○	○	○	○	○	○	○
Touch current : Enclosure - Enclosure	○	○	○	○	○	○	○	○	○
Patient leakage current : Patient - Earth	-	-	-	-	-	-	-	-	-
Patient leakage current : SIP/SOP	-	○	○	-	○	○	-	○	○
Patient leakage current : F-type applied part	-	-	-	-	-	-	-	-	-
Patient leakage current : Metal accessible part	-	-	-	-	-	-	-	-	-
Total patient leakage current : Patient - Earth	-	-	-	-	-	-	-	-	-
Total patient leakage current : SIP/SOP	-	○	○	-	○	○	-	○	○
Total patient leakage current : F-type applied part	-	-	-	-	-	-	-	-	-
Total patient leakage current : Metal accessible part	-	-	-	-	-	-	-	-	-
Patient auxiliary current	-	-	-	-	-	-	-	-	-
Free current	○	○	○	○	○	○	○	○	○

○: Can be set, -: Cannot be set

Sets and queries the set measurement current (protective conductor ammeter)

Syntax	Command	<code>:CONFigure:PCC <characters></code>
	Query	<code>:CONFigure:PCC?</code>
	Response	<code><characters></code> <code><characters>= ACDC/AC/DC/ACPEAK</code> ACDC : AC+DC(alternating current and direct current) AC : Alternating current DC : Direct current ACPEAK : ACPeak
Function	Command	Sets protective conductor current.
	Query	Returns protective conductor current setting as alphabetic characters.
Example	Command	<code>:CONFigure:PCC ACDC</code> Sets protective conductor current to AC + DC.
	Query	<code>:CONFigure:PCC?</code>
	Response	<code>:CONFIGURE:PCC ACDC (Headers : ON)</code> <code>ACDC (Headers : OFF)</code> Protective conductor current has been set to AC + DC.
Error		Mode is set to something other than "protective conductor ammeter mode". Setting ACPeak when the frequency range is set between 0.1 Hz and 1 MHz causes an execution error.
Note		Use this command after using the <code>:SYSTEM:MODE</code> command to set the protective conductor ammeter mode. Setting a frequency range from 0.1 Hz will activate the following settings. <ul style="list-style-type: none"> • Leakage current mode: When measured current is ACPeak, ACDC is used. • In the AUTO range, HOLD3 is used. • Voltmeter mode: In AUTO range, HOLD3 is used. • Protective conductor ammeter mode: Frequency range setting is disabled and operation starts from a 15 Hz setting.

Sets and queries current range (protective conductor ammeter)

Syntax	Command	<code>:CONFigure:PCC:RANGE <characters></code>
	Query	<code>:CONFigure:PCC:RANGE?</code>
	Response	<code><characters></code> <code><characters>= HOLD1/HOLD2</code> HOLD1:50mA range HOLD2:10mA range
Function	Command	Sets the current range for protective conductor ammeter.
	Query	Returns the current range for protective conductor ammeter setting as alphabetic characters.
Example	Command	<code>:CONFigure:PCC:RANGE HOLD1</code> Sets the 50 mA range as current range for protective conductor ammeter.

8.7 Command Message Description

Sets and queries current range (protective conductor ammeter)

Query	:CONFigure:PCC:RANGe?
Response	:CONFIGURE:PCC:RANGE HOLD1 (Headers : ON) HOLD1 (Headers : OFF) The current range for protective conductor ammeter is set to the 50 mA range. Mode is set to something other than "protective conductor ammeter mode".
Error	
Note	Use this command after using the :SYSTem:MODE command to set the protective conductor ammeter mode.

Sets and queries the power supply polarity in manual measurement

Syntax	Command :CONFigure:POLarity <characters> Query :CONFigure:POLarity? Response <characters> <characters> = NORMAl/ REVerse NORMAl : Positive phase REVerse : Negative phase
Function	Command Sets the power supply polarity for manual measurement. Query Returns the power supply polarity setting for manual measurement as alphabetic characters.
Example	Command :CONFigure:AUTO OFF::CONFigure:POLarity NORMAl Sets the power supply polarity to positive phase. Query :CONFigure:AUTO OFF::CONFigure:POLarity? Response :CONFIGURE:POLARITY NORMAL (Headers : ON) NORMAL (Headers : OFF) The power supply polarity has been set to positive phase.
Error	An execution error occurs in the following cases: <ul style="list-style-type: none"> • When the measurement method is set to "automatic measurement" • When a mode other than "leakage current mode" is set • When the measurement mode is set to Enclosure - Line leakage current, Touch current Enclosure - Line or the measurement mode is not set • When the type of equipment under test is set to "internally powered equipment" • When the auto range is set and a 0.1 Hz frequency range setting is made. • When power on polarity switching is set and a power on check ends in an error (NG), it is the instrument that is causing the error.
Note	Use this command after executing the :MODE command to activate the measurement mode.

Sets and queries the current range

Syntax	Command	:CONFigure:RANGE <characters>
	Query	:CONFigure:RANGE?
	Response	<characters> <characters> = AUTO/ HOLD1/ HOLD2/ HOLD3/ HOLD4 AC, DC, AC+DC AUTO : Auto range HOLD1: 50.00 mArange HOLD2: 5.000 mArange HOLD3: 500.0 μ Arange HOLD4: 50.00 μ Arange ACpeak AUTO : Auto range HOLD1: 75.00 mArange HOLD2: 10.00 mArange HOLD3: 1.000 mArange HOLD4: 500.0 μ Arange
Function	Command	Sets the current range.
	Query	Returns the current range setting as alphabetic characters.
Example	Command	:CONFigure:RANGE AUTO Sets the current range to the Auto range.
	Query	:CONFigure:RANGE?
	Response	:CONFigure:RANGE AUTO (Headers : ON) AUTO (Headers : OFF) The current range has been set to the Auto range.
Error		An execution error occurs in the following cases : <ul style="list-style-type: none"> • When the measurement mode is not selected • When a mode other than "leakage current mode" is set • In automatic measurement(Command) • When currency range is set to auto range and frequency range is set from 0.1 Hz.

Specific manual measurement: Sets and queries the application of 110% of rated voltage(only ST5540)

Syntax	Command	:CONFigure:SPECIAL <characters>
	Query	:CONFigure:SPECIAL?
	Response	<characters> <characters> = NAPPLY/RAPPLY NAPPLY : Application of 110% voltage : Positive phase RAPPLY : Application of 110% voltage : Negative phase
Function	Command	Specific manual measurement: Sets the application of 110% of rated voltage.
	Query	Specific manual measurement : Returns the application of 110% of rated voltage as alphabetic characters

8.7 Command Message Description

Specific manual measurement: Sets and queries the application of 110% of rated voltage(only ST5540)

Example Command :**CONFigure:AUTO OFF;;CONFigure:SPECIAL NAPPLY**
 Specific manual measurement: Sets the application of 110% of rated voltage as positive phase.

Query :**CONFigure:AUTO OFF;;CONFigure:SPECIAL?**

Response :**CONFIGURE:SPECIAL NAPPLY** (Headers : ON)
NAPPLY (Headers : OFF)
 Specific manual measurement: The application of 110% of rated voltage has been set to positive phase.

Error

An execution error occurs in the following cases:

- When the measurement method is set to "automatic measurement"
- When a mode other than "leakage current mode" is set
- When a Network other than "B1" or "B2" is set
- When a measurement mode other than Patient leakage current, F-type applied part, Patient leakage current : Metal accessible part, Total patient leakage current : F-type applied part, Total patient leakage current : Metal accessible part is set

Note

- Use this command after executing the :**MODE** command to activate the measurement mode.
- Use this command after using the :**NETWork** command to enter the "B1" or "B2" network.
- Use this command after executing the :**MODE** command to activate Patient leakage current:F-type applied part, Patient leakage current : Metal accessible part, Total patient leakage current : F-type applied part, Total patient leakage current : Metal accessible part.

When network B2 is selected

Measurement modes	Special test condition (Specific applied voltage)					
	Class-I equipment		Class-II equipment		Internally powered equipment	
	Application of 110% voltage: Positive phase	Application of 110% voltage: Negative phase	Application of 110% voltage: Positive phase	Application of 110% voltage: Negative phase	Application of 110% voltage: Positive phase	Application of 110% voltage: Negative phase
Earth leakage current	–	–	–	–	–	–
Touch current : Enclosure - Earth	–	–	–	–	–	–
Touch current : Enclosure - Enclosure	–	–	–	–	–	–
Patient leakage current :Patient - Earth	–	–	–	–	–	–
Patient leakage current :SIP/SOP	–	–	–	–	–	–
Patient leakage current : F-type applied part	○	○	○	○	○	○
Patient leakage current : Metal accessible part	○	○	○	○	○	○

○: Can be set, –: Cannot be set

8.7 Command Message Description

Measurement modes	Special test condition (Specific applied voltage)					
	Class-I equipment		Class-II equipment		Internally powered equipment	
	Application of 110% voltage: Positive phase	Application of 110% voltage: Negative phase	Application of 110% voltage: Positive phase	Application of 110% voltage: Negative phase	Application of 110% voltage: Positive phase	Application of 110% voltage: Negative phase
Total patient leakage current : Patient - Earth	–	–	–	–	–	–
Total patient leakage current : SIP/SOP	–	–	–	–	–	–
Total patient leakage current : F-type applied part	○	○	○	○	○	○
Total patient leakage current : Metal accessible part	○	○	○	○	○	○
Patient auxiliary current	–	–	–	–	–	–
Free current	–	–	–	–	–	–

○: Can be set, –: Cannot be set

Sets and queries switches(only ST5540)

Syntax Command : `CONFfigure:SWITCh <characters>`
 Query : `CONFfigure:SWITCh?`
 Response `<character value 1>,<character value 2>,<character value 3>`
`<character value 1> = OFF/ON`
 OFF : S10 : OFF
 ON : S10 : ON
`<character value 2> = OFF/ON`
 OFF : S12 : OFF
 ON : S12 : ON
`<character value 3> = OFF/ON`
 OFF : S13 : OFF
 ON : S13 : ON

Function Command Sets manual measurement switches.
 Query Returns the manual measurement switches setting as alphabetic characters.

Example Command : `CONFfigure:AUTO OFF;;CONFfigure:SWITCh ON,OFF,OFF`
 Sets manual measurement switches to S10=ON, S12=OFF, S13=OFF.
 Query : `CONFfigure:AUTO OFF;;CONFfigure:SWITCh?`
 Response : `CONFfigure:SWITCh ON,OFF` (Headers : ON)
`ON,OFF,OFF` (Headers : OFF)
 Manual measurement switches has been set to S10=ON, S12=OFF, S13=OFF.

Sets and queries switches(only ST5540)**Error**

An execution error occurs in the following cases :

- During automatic measurement
- When a mode other than "leakage current mode" is set
- When a Network other than "B1 or B2" is set
- Setting not possible under existing conditions

For details, see the table below.

An execution error occurs when none of S10, S12 and S13 can be set.

- Use this command after executing the **:MODE** command to activate the measurement mode.
- Use this command after using the **:NETWork** command to enter the B1 or B2 network.
- Settings may not be possible for some equipment under test and measurement modes. For details, see the table below.

Note

- Use this command after executing the **:MODE** command to activate the measurement mode.
- Use this command after using the **:NETWork** command to enter the B1 or B2 network.
- Settings may not be possible for some equipment under test depending on equipment under test setting and mode. For details, see table on next page. When S10, S12 or S13 can be set, turn off the settings that cannot be set.

8.7 Command Message Description

When network B1 is selected

Measurement mode	Switch	Class-I equipment			Class-II equipment			Internally powered equipment		
		S10	S12	S13	S10	S12	S13	S10	S12	S13
Earth leakage current		○	○	–	–	–	–	–	–	–
Enclosure - Earth leakage current		○	○	–	○	○	–	–	–	–
Enclosure - Enclosure current		○	○	–	○	○	–	–	–	–
Patient leakage current I		○	–	○	○	–	○	–	–	–
Patient leakage current II		○	–	○	○	–	○	–	–	–
Patient leakage current III		○	–	○	○	–	○	–	–	–
Patient auxiliary current		○	–	–	○	–	–	–	–	–
Free current		○	○	–	○	○	–	–	–	–

When network B2 is selected

Measurement mode	Switch	Class-I equipment			Class-II equipment			Internally powered equipment		
		S10	S12	S13	S10	S12	S13	S10	S12	S13
Earth leakage current		○	○	–	–	–	–	–	–	–
Touch current: Enclosure - Earth		○	○	–	○	○	–	–	–	–
Touch current: Enclosure - Enclosure		○	○	–	○	○	–	–	–	–
Patient leakage current: (Patient - Earth)		○	–	○	○	–	○	–	–	–
Patient leakage current:SIP/SOP		○	–	○	○	–	○	–	–	–
Patient leakage current: F-type applied part		○	–	○	○	–	○	–	–	–
Patient leakage current: Metal accessible part		○	–	–	○	–	–	–	–	–
Total patient leakage current: (Patient - Earth)		○	–	○	○	–	○	–	–	–
Total patient leakage current: SIP/SOP		○	–	○	○	–	○	–	–	–
Total patient leakage current: F-type applied part		○	–	○	○	–	○	–	–	–
Total patient leakage current: Metal accessible part		○	–	–	○	–	–	–	–	–
Patient auxiliary current		○	–	–	○	–	–	–	–	–
Free current		○	○	–	○	○	–	–	–	–

8.7 Command Message Description

Sets and queries the measurement terminal of the Patient leakage current (Patient - Earth) and the total patient leakage current (Patient - Earth) (only ST5540)

Syntax	Command :CONFigure:TERMinal <characters> Query :CONFigure:TERMinal? Response <characters> <characters> = T1T2/T2 T1T2:Terminal T1 and Terminal T2 T2:Terminal T2 and grounding terminal
Function	Command Sets the measurement terminal of the Patient leakage current (Patient - Earth) and the total patient leakage current (Patient - Earth) Query Returns the setting of the measurement terminal of the Patient leakage current (Patient - Earth) and the total patient leakage current (Patient - Earth) in characters.
Example	Command :CONFigure:TERMinal T1T2 Sets the measurement terminal of the Patient leakage current (Patient - Earth) and the total patient leakage current (Patient - Earth) to T1 and T2 terminals. Query :CONFigure:TERMinal? Response :CONFIGURE:TERMINAL T1T2 (Headers: ON) T1T2 (Headers: OFF) Measurement terminal of the Patient leakage current (Patient - Earth) and the total patient leakage current (Patient - Earth) are set to T1 and T2 terminals.
Error	An execution error occurs in the following cases: <ul style="list-style-type: none"> • When measurement mode is other than the patient leakage current (Patient - Earth) or the total patient leakage current (Patient - Earth) • When a mode other than "leakage ammeter mode" is set • The grounding class of equipment under test is set to something other than internally powered equipment • During automatic measurements
Note	Use this command after executing the :MODE command to activate the measurement mode.

Sets and queries the target voltage

Syntax	Command :CONFigure:VOLTage <characters> Query :CONFigure:VOLTage? Response <characters> <characters> = ACDC/ AC/ DC/ACPEAK ACDC : AC+DC(alternating current and direct current) AC : Alternating current DC : Direct current ACPEAK : AC peak
Function	Command Sets the target voltage. Query Returns the target voltage setting as alphabetic characters.

Sets and queries the target voltage

Example	Command	<code>:CONFigure:VOLTage ACDC</code> Sets the target voltage to AC+DC.
	Query	<code>:CONFigure:VOLTage?</code>
	Response	<code>:CONFIGURE:VOLTAGE ACDC</code> (Headers : ON) <code>ACDC</code> (Headers : OFF) The target voltage has been set to AC+DC.
Error	An execution error occurs when mode is set to something other than "voltmeter mode."	
Note	Use this command after executing the <code>:SYSTEM:MODE</code> command to set the instrument into voltmeter mode.	

Sets and queries the voltage range

Syntax	Command	<code>:CONFigure:VOLTage:RANGE <characters></code>
	Query	<code>:CONFigure:VOLTage:RANGE?</code>
	Response	<code><characters></code> <code><characters></code> = AUTO/ HOLD1/ HOLD2/ HOLD3/ HOLD4 AUTO : Auto range HOLD1 : 50.00 V range HOLD2 : 5.000 V range HOLD3 : 500.0 mV range HOLD4 : 50.00 mV range
Function	Command	Sets the voltage range.
	Query	Returns the voltage range setting as alphabetic characters.
Example	Command	<code>:CONFigure:VOLTage:RANGE AUTO</code> Sets the voltage range to the Auto range.
	Query	<code>:CONFigure:VOLTage:RANGE?</code>
	Response	<code>:CONFIGURE:VOLTAGE:RANGE AUTO</code> (Headers: ON) <code>AUTO</code> (Headers: OFF) The voltage range has been set to the Auto range.
Error	An execution error occurs when mode is set to something other than "voltmeter mode."	
Note	Use this command after executing the <code>:SYSTEM:MODE</code> command to set the instrument into voltmeter mode. Setting auto range when the frequency range is set between 0.1 Hz and 1 MHz causes an execution error.	

Sets and queries the wait time for switching operation in automatic measurement (delay c)

Syntax	Command	<code>:CONFigure:WTIME:ETC <numerical value></code>
	Query	<code>:CONFigure:WTIME:ETC?</code>
	Response	<code><numerical value></code> <code><numerical value></code> = 1 to 1800 (NR1)

8.7 Command Message Description

Sets and queries the wait time for switching operation in automatic measurement (delay c)

Function	Command	Sets the wait time for switching operation in automatic measurement (delay c).
	Query	Returns the wait time setting (delay c) for switching operation in automatic measurement as a numeric value.
Example	Command	<code>:CONFigure:AUTO ON;:CONFigure:WTIME:ETC 10</code> Sets the wait time (delay c) for switching operation in automatic measurement to 10 seconds.
	Query	<code>:CONFigure:AUTO ON;:CONFigure:WTIME:ETC?</code>
	Response	<code>:CONFIGURE:WTIME:ETC 1200 (Headers: ON)</code> <code>1200 (Headers: OFF)</code> The wait time (delay c) for switching operation in automatic measurement has been set to 1,200 seconds.
Error	<p>An execution error occurs in the following cases:</p> <ul style="list-style-type: none"> • When the measurement method is set to "manual measurement" • When the measurement mode is not selected • When a mode other than "leakage current mode" is set • In automatic measurement(Command) • When a value outside the specified range is input 	
Note	<ul style="list-style-type: none"> • Use this command after executing the <code>:MODE</code> command to activate the measurement mode. • The unit is [s]. Fractions are rounded up when 0.5 or greater and rounded off when less than 0.5. 	

Sets and queries the wait time for switching operation in automatic measurement (delay a)

Syntax	Command	<code>:CONFigure:WTIME:LINE <numerical value></code>
	Query	<code>:CONFigure:WTIME:LINE?</code>
	Response	<code><numerical value></code> <code><numerical value> = 0 to 1800 (NR1)</code>
Function	Command	Sets the wait time (delay a) for switching operation in automatic measurement.
	Query	Returns the wait time setting (delay a) for switching operation in automatic measurement as a numeric value.
Example	Command	<code>:CONFigure:AUTO ON;:CONFigure:WTIME:LINE 10</code> Sets the wait time (delay a) for switching operation in automatic measurement to 10 seconds.
	Query	<code>:CONFigure:AUTO ON;:CONFigure:WTIME:LINE?</code>
	Response	<code>:CONFIGURE:WTIME:LINE 1200 (Headers:ON)</code> <code>1200 (Headers:OFF)</code> The wait time (delay a) for switching operation in automatic measurement has been set to 1,200 seconds.
Error	<p>An execution error occurs in the following cases :</p> <ul style="list-style-type: none"> • When the measurement method is set to "manual measurement" • When the measurement mode is not selected • When a mode other than "leakage current mode" is set • In automatic measurement(Command) • When a value outside the specified range is input 	

Sets and queries the wait time for switching operation in automatic measurement (delay a)

- Note**
- Use this command after executing the `:MODE` command to activate the measurement mode.
 - The unit is [s]. Fractions are rounded up when 0.5 or greater and rounded off when less than 0.5.

Sets and queries the wait time for switching operation in automatic measurement (delay b2)

Syntax	Command	<code>:CONFigure:WTIME:POLarity <numerical value></code>
	Query	<code>:CONFigure:WTIME:POLarity?</code>
	Response	<code><numerical value></code> <code><numerical value> = 1 to 1800 (NR1)</code>
Function	Command	Sets the wait time (delay b2) for switching operation in automatic measurement.
	Query	Returns the wait time setting (delay b2) for switching operation in automatic measurement as a numeric value.
Example	Command	<code>:CONFigure:AUTO ON;:CONFigure:WTIME:POLarity 10</code> Sets the wait time (delay b2) for switching operation in automatic measurement to 10 seconds.
	Query	<code>:CONFigure:AUTO ON;:CONFigure:WTIME:POLarity?</code>
	Response	<code>:CONFIGURE:WTIME:POLARITY 1200</code> (Headers: ON) <code>1200</code> (Headers: OFF) The wait time (delay b2) for switching operation in automatic measurement has been set to 1,200 seconds.
Error		An execution error occurs in the following cases: <ul style="list-style-type: none"> • When the measurement method is set to "manual measurement" • When the measurement mode is not selected • When a mode other than "leakage current mode" is set • In automatic measurement(Command) • When a value outside the specified range is input
Note		<ul style="list-style-type: none"> • Use this command after executing the <code>:MODE</code> command to activate the measurement mode. • The unit is [s]. Fractions are rounded up when 0.5 or greater and rounded off when less than 0.5.

Sets and queries the wait time for switching operation in automatic measurement (delay b1)

Syntax	Command	<code>:CONFigure:WTIME:POLarity0<numerical value></code>
	Query	<code>:CONFigure:WTIME:POLarity0?</code>
	Response	<code><numerical value></code> <code><numerical value>= 0 to 1800(NR1)</code>
Function	Command	Sets the wait time (delay b1) for switching operation in automatic measurement.
	Query	Returns the wait time setting (delay b1) for switching operation in automatic measurement as a numeric value.

8.7 Command Message Description

Sets and queries the wait time for switching operation in automatic measurement (delay b1)

Example	<p>Command <code>:CONFigure:AUTO ON;:CONFigure:WTime:POLarity0 10</code> Sets the wait time (delay b1) for switching operation in automatic measurement to 10 seconds.</p> <p>Query <code>:CONFigure:WTime:POLarity0?</code></p> <p>Response <code>:CONFIGURE:WTIME:POLARITY0 1200</code> (Headers : ON) <code>1200</code> (Headers : OFF) The wait time (delay b1) for switching operation in automatic measurement has been set to 1,200 seconds.</p>
Error	<p>An execution error occurs in the following cases :</p> <ul style="list-style-type: none"> • When the measurement method is set to "manual measurement" • When the measurement mode is not selected • When a mode other than "leakage current mode" is set • In automatic measurement (Command) • When a value outside the specified range is input
Note	<ul style="list-style-type: none"> • Use this command after executing the <code>:MODE</code> command to activate the measurement mode. • The unit is [s]. Fractions are rounded up when 0.5 or greater and rounded off when less than 0.5.

Sets and queries the grounding class of equipment under test

Syntax	<p>Command <code>:EQUIPMENT <characters></code></p> <p>Query <code>:EQUIPMENT?</code></p> <p>Response <code><characters></code> <code><characters></code> = CLAss1(CLA1)/ CLAss2(CLA2)/ INTernal CLAss1 : Class-I equipment CLAss2 : Class-II equipment INTernal: Internally powered equipment</p>
Function	<p>Command Sets the grounding class of equipment under test.</p> <p>Query Returns the grounding class setting of equipment under test as alphabetic characters.</p>
Example	<p>Command <code>:MODE OFF;:EQUIPMENT CLAss1</code> Sets the grounding class of equipment under test to "Class-I equipment."</p> <p>Query <code>:EQUIPMENT?</code></p> <p>Response <code>:EQUIPMENT CLASS1</code> (Headers : ON) <code>CLASS1</code> (Headers : OFF) The grounding class of equipment under test has been set to "Class-I equipment."</p>
Error	<p>An execution error occurs in the following cases:</p> <ul style="list-style-type: none"> • When the measurement mode is selected (Command) • When a mode other than "leakage current mode" is set (Command)

Sets and queries the equipment name/control number of equipment under test

Syntax	Command	:EQUIPMENT:IDENTITY <character value 1>,<character value 2>
	Query	:EQUIPMENT:IDENTITY?
	Response	<character value 1>,<character value 2> <character value 1> = Equipment name (text data with 1 to 12 characters) <character value 2>= Control number (text data with 1 to 12 characters)
Function	Command	Sets the equipment name/control number of equipment under test.
	Query	Returns the equipment name/control number setting of equipment under test.
Example	Command	:EQUIPMENT:IDENTITY ABC,NO-111 Sets the equipment name/control number of equipment under test to "ABC" and "NO-111," respectively.
	Query	:EQUIPMENT:IDENTITY?
	Response	:EQUIPMENT:IDENTITY ABC,NO-111 (Headers : ON) ABC,NO-111 (Headers : OFF) The equipment name/control number of equipment under test have been set to "ABC" and "NO-111," respectively.
Error		An execution error occurs in the following cases: <ul style="list-style-type: none"> • When the measurement mode is selected(Command) • When a mode other than "leakage current mode" is set(Command) • If the character string does not conform to the specified format (Command)
Note		<ul style="list-style-type: none"> • Use this command after executing the :MODE command to activate OFF mode (i.e., measurement mode not selected). • Alphanumeric characters and hyphens (-) can be used. All letters are treated as uppercase (not case-sensitive). The equipment name and control number need not be set except when measurement data is saved in memory.

Sets and queries the applied part of equipment under test (Network B1, B2 only)(only ST5540)

Syntax	Command	:EQUIPMENT:TYPE <characters>
	Query	:EQUIPMENT:TYPE?
	Response	<characters> <characters> = B/ BF/ CF B : Type B applied part BF : Type BF applied part CF : Type CF applied part
Function	Command	Sets the applied part of equipment under test.
	Query	Returns the applied part setting of equipment under test.
Example	Command	:EQUIPMENT:TYPE B Sets the applied part of equipment under test to Type B applied part.
	Query	:EQUIPMENT:TYPE?
	Response	:EQUIPMENT:TYPE B (Headers: ON) B (Headers: OFF) The applied part of equipment under test has been set to Type B applied part.

8.7 Command Message Description

Sets and queries the applied part of equipment under test (Network B1, B2 only)(only ST5540)

Error	An execution error occurs in the following cases: <ul style="list-style-type: none"> • When network A, C, D, E, F or G is selected • When a mode other than "leakage current mode" is set • When network B1 or B2 is selected When the measurement mode is selected (Command)
Note	Use this command after executing the <code>:MODE</code> command to activate OFF mode (i.e., measurement mode not selected).

Queries the event status register 0

Syntax	Query	<code>:ESR0?</code>																								
	Response	<code><numerical value></code> <code><numerical value> = 0 to 255 (NR1)</code>																								
Function	Query	Returns the setting content of event status register 0 (ESR0) as a numeric value, then clears the content. No header is prefixed to the response message.																								
		<table style="width: 100%; text-align: center; border-collapse: collapse;"> <tr> <td>128</td> <td>64</td> <td>32</td> <td>16</td> <td>8</td> <td>4</td> <td>2</td> <td>1</td> </tr> <tr> <td>bit 7</td> <td>bit 6</td> <td>bit 5</td> <td>bit 4</td> <td>bit 3</td> <td>bit 2</td> <td>bit 1</td> <td>bit 0</td> </tr> <tr> <td style="border: 1px solid black;">Not used</td> <td style="border: 1px solid black;">ERROR</td> <td style="border: 1px solid black;">LOW</td> <td style="border: 1px solid black;">TEST</td> <td style="border: 1px solid black;">MEAS</td> <td style="border: 1px solid black;">T-FAIL</td> <td style="border: 1px solid black;">FAIL</td> <td style="border: 1px solid black;">PASS</td> </tr> </table>	128	64	32	16	8	4	2	1	bit 7	bit 6	bit 5	bit 4	bit 3	bit 2	bit 1	bit 0	Not used	ERROR	LOW	TEST	MEAS	T-FAIL	FAIL	PASS
128	64	32	16	8	4	2	1																			
bit 7	bit 6	bit 5	bit 4	bit 3	bit 2	bit 1	bit 0																			
Not used	ERROR	LOW	TEST	MEAS	T-FAIL	FAIL	PASS																			
Example	Query	<code>:ESR0?</code>																								
	Response	<code>1</code> Bit 0 of ESR0 has been set to 1.																								
Error		If the response message exceeds the output queue size, a query error occurs.																								

Sets and queries the response header

Syntax	Command	<code>:HEADer <characters></code>
	Query	<code>:HEADer?</code>
	Response	<code><characters></code> <code><characters> = ON/OFF</code> ON : With response header OFF : Without response header
Function	Command	Sets the response header of the query. (default setting : OFF)
	Query	Returns the response header setting as alphabetic characters.
Example	Command	<code>:HEADer OFF</code> Sets the response header to OFF.
	Query	<code>:HEADer?</code>
	Response	<code>:HEADER ON</code> (Headers : ON) The response header has been set to ON. <code>OFF</code> (Headers : OFF) The response header has been set to OFF.

Sets and queries the application line for leakage current measurement between enclosure and line

Syntax	Command	:LINE <characters>
	Query	:LINE?
	Response	<characters> <characters> = INT/ EXT INT : Uses internal contact. (internal contact and terminal T2) EXT : Uses external contact. (terminals T1 and T2)
Function	Command	Sets the application line for Touch current Enclosure - Line or Enclosure - Line leakage current.
	Query	Returns the setting of the application line for Touch current Enclosure - Line or Enclosure - Line leakage current.
Example	Command	:LINE INT Sets the application line for Touch current Enclosure - Line or Enclosure - Line leakage current to "internal contact."
	Query	:LINE?
	Response	:LINE INT (Headers : ON) INT (Headers : OFF) Use of internal contact has been set.
Error		An execution error occurs in the following cases: <ul style="list-style-type: none"> • When the measurement mode is not set to Touch current Enclosure - Line, Enclosure - Line leakage current. • When a mode other than "leakage current mode" is set • When the measurement method is set to "automatic measurement"(Command)

Clears the maximum value

Syntax	Command	:MAXimum:CLEar
Function	Command	Clears the maximum value.
Example	Command	:MAXimum:CLEar Clears the maximum value.
Error		An execution error occurs in the following cases: <ul style="list-style-type: none"> • When the measurement mode is not selected • When a mode other than "leakage current mode" is set • In automatic measurement
Note		Use this command after executing the :MODE command to activate the measurement mode.

Queries the measurement value

Syntax	Query	:MEASure?
	Response	<numerical value 1>,<numerical value 2> <numerical value 1> = Measurement value (NR3) <numerical value 2> = Judgement (NR1) 0: Equal to or less than the allowable value (PASS) 1: Greater than the allowable value(upper limit) (FAIL) 2: Smaller than the allowable value (lower limit) (LOW) 3: No judgment
Function	Query	Returns the measurement value and judgement result as numeric values. The data is arranged as follows : <Measurement value>,<Judgement> (unit : A)
Example	Query	:MEASure?
	Response	:MEASURE +2.345E-03,1 (Headers : ON) +2.345E-03,1 (Headers : OFF) The example of response data is shown below : Measurement valueJudgement 2.345 mA FAIL
Error		An execution error occurs in the following cases : <ul style="list-style-type: none"> • When the measurement method is set to "automatic measurement" • When the measurement mode is not selected
Note		<ul style="list-style-type: none"> • Use this command after executing the :MODE command to activate the measurement mode. • When [MEASure?] command is transmitted before the appropriate measurement range is selected in the Auto range, there is the case that the right measurement value is not received by PC

Queries the maximum value after automatic measurement

Syntax	<p>Query :MEASure:AUTO?</p> <p>Response <numerical value 1>,<numerical value 2>,<numerical value 3>,<numerical value 4>,<numerical value 5>,<numerical value 6>,<numerical value 7></p> <p><numerical value 1> = Maximum value(NR3)</p> <p><numerical value 2> = Judgement(NR1)</p> <p>0 : Equal to or less than the allowable value(PASS)</p> <p>1 : Greater than the allowable value(upper limit)(FAIL)</p> <p>2 :Smaller than the allowable value (lower limit)(LOW)</p> <p>3 :No judgment</p> <p><numerical value 3> = Power supply polarity(NR1)</p> <p>0 : Positive phase</p> <p>1 : Negative phase</p> <p>(When the equipment under test is internally powered equipment, touch current (enclosure - line). When enclosure - line leakage current, the value is 0)</p> <p><numerical value 4> = Equipment under test status(NR1)</p> <p>0 : Normal condition</p> <p>1 : Single-fault condition(Disconnection of one wire in power line)</p> <p>2 : Single-fault condition(Disconnection of protective earth conductor)</p> <p>3 : Single-fault condition</p> <p>(Application of 110% voltage: Positive phase)</p> <p>4 : Single-fault condition</p> <p>(Application of 110% voltage: Negative phase)</p> <p>5 : Single-fault condition (line voltage application : L)</p> <p>6 : Single-fault condition (line voltage application : N)</p> <p><numerical value 5> = Target current (NR1)</p> <p>0 : AC+DC</p> <p>1 : AC</p> <p>2 : DC</p> <p>3 : ACpeak</p> <p><numerical value 6> = Other 110% voltage application</p> <p>0 : Application of 110% voltage:none</p> <p>1 : Application of 110% voltage:Positive phase</p> <p>2 : Application of 110% voltage:Negative phase</p> <p>(0 for ST5541)</p> <p><numerical value 7> = Specific 110% voltage application</p> <p>0 : Application of 110% voltage:none</p> <p>1 : Application of 110% voltage:Positive phase</p> <p>2 : Application of 110% voltage:Negative phase</p> <p>(0 for ST5541)</p>
Function	<p>Query</p> <p>Returns all measurement results at once after automatic measurement.</p> <p>Returns power supply polarity, the maximum value in each combination of equipment under test status, the corresponding judgment, power supply polarity and equipment under test status as a numeric value.</p> <p>The data is arranged as follows : <1.Maximum value>, <2.Judgement>, <3.Power supply polarity>, <4.Equipment under test status>, <5.Target current>, <6.Other 110% voltage application>, <7.Specific 110% voltage application>, ...</p> <p>Data 1 through 7 are repeated as many times as the number of automatic measurement combinations.</p> <p>(unit of (1) maximum value : A)</p>

Queries the maximum value after automatic measurement

Example Query :MEASure:AUTO?
 Response :MEASURE:AUTO +2.345E-03,0,0,0,0,0,0,
 +2.362E-03,0,1,0,0,0,0,+2.510E-03,0,0,2,0,0,0,
 +2.610E-03,1,1,2,0,0,0,+2.456E-03,0,0,1,0,0,0,
 +2.459E-03,0,1,1,0,0,0 (Headers : ON)
 +2.345E-03,0,0,0,0,0,0,+2.362E-03,0,1,0,0,0,0,
 +2.510E-03,0,0,2,0,0,0,+2.610E-03,1,1,2,0,0,0,
 +2.456E-03,0,0,1,0,0,0,+2.459E-03,0,1,1,0,0,0
 (Headers: OFF)

The example of response data is shown below:

Maximum value	Judgement	Power supply polarity	Equipment under test status	Target current
2.345 mA	PASS	Positive phase	Normal condition	AC + DC
2.362 mA	PASS	Negative phase	Normal condition	AC + DC
2.510 mA	PASS	Positive phase	Single-fault condition (Disconnection of protective earth conductor)	AC + DC
2.610 mA	FAIL	Negative phase	Single-fault condition (Disconnection of protective earth conductor)	AC + DC
2.456 mA	PASS	Positive phase	Single-fault condition (Disconnection of one wire in power line)	AC + DC
2.459 mA	PASS	Negative phase	Single-fault condition (Disconnection of one wire in power line)	AC + DC

Error

An execution error occurs in the following cases :

- When the measurement method is set to "manual measurement"
- When the measurement mode is not selected
- Before the start of automatic measurement
- When automatic measurements end in an error

Note

- Use this command after executing the :MODE command to activate the measurement mode.
- Execute this command after confirming the completion of automatic measurement (:AMC? command). If the command is executed during automatic measurement, correct measurement results cannot be obtained.

Queries the maximum value

Syntax	Query	:MEASure:MAXimum?
	Response	<numerical value 1>,<numerical value 2>,<numerical value 3>,<numerical value 4>,<numerical value 5>,<numerical value 6>,<numerical value 7> <numerical value 1> = Maximum value (NR3) <numerical value 2> = Judgement (NR1) 0 : Equal to or less than the allowable value (PASS) 1 : Greater than the allowable value (upper limit)(FAIL) 2 : Smaller than the allowable value (lower limit)(LOW) 3 : No judgment <numerical value 3> = Power supply polarity (NR1) (When the equipment under test is internally powered equipment, touch current (enclosure - line). When enclosure - line leakage current, the value is 0) 0 : Positive phase 1 : Negative phase <numerical value 4> = Equipment under test status (NR1) 0 : Normal condition 1 : Single-fault condition (Disconnection of one wire in power line) 2 : Single-fault condition (Disconnection of protective earth conductor) 3 : Single-fault condition (Application of 110% voltage : Positive phase) 4 : Single-fault condition (Application of 110% voltage : Negative phase) 5 : Single-fault condition (line voltage application : L) 6 : Single-fault condition (line voltage application : N)
Syntax	Response	<numerical value 5> = Target current(NR1) 0 : AC+DC 1 : AC 2 : DC 3 : ACpeak <numerical value 6> = Other 110% voltage application 0 : Application of 110% voltage : none 1 : Application of 110% voltage : Positive phase 2 : Application of 110% voltage : Negative phase (0 for ST5541) <numerical value 7> = Specific 110% voltage application 0 : Application of 110% voltage : none 1 : Application of 110% voltage : Positive phase 2 : Application of 110% voltage : Negative phase (0 for ST5541)
Function	Query	Returns the maximum value, the corresponding judgment, power supply polarity and equipment under test status as a numeric value. The data is arranged as follows : <1.Maximum value>, <2.Judgement>, <3.Power supply polarity>, <4.Equipment under test status>, <5.Target current>, <6.Other 110% voltage application>, <7.Specific 110% voltage application> (unit of (1) maximum value : A)
Example	Query	:MEASure:MAXimum?
	Response	:MEASURE:MAXIMUM +2.345E-03,1,1,2,0,0,0 (Headers: ON) +2.345E-03,1,1,2,0,0,0 (Headers: OFF) The example of response data is shown below :

8.7 Command Message Description

Queries the maximum value

Maximum value	Judge ment	Power supply polarity	Equipment under test status	Target current	Other 110% voltage application	Specific 110% voltage application
2.345 mA	FAIL	Negative phase	Single-fault condition(Disconnection of protective earth conductor)	AC+DC	none	none

Error If the measurement mode is not set, an execution error occurs.
When there is no maximum value, +9.999E+10,3,0,0,0,0 will be displayed.

Note

- To obtain the maximum value acquired in automatic measurement, execute this command after confirming the completion of automatic measurement (:AMC? command). If the command is executed during automatic measurement, the maximum value at command execution is obtained.
- Use this command after executing the :MODE command to activate the measurement mode.

Queries the protective conductor current measurement value

Syntax Query :MEASure:PCC?
Response <numerical value>
<numerical value>=Measurement value(NR3)

Function Query Returns protective conductor current measurement value as a numeric value.
(unit : A)

Example Query :MEASure:PCC?
Response :MEASURE:PCC +2.345E-03 (Headers : ON)
+2.345E-03 (Headers : OFF)
Protective conductor current measurement value is 2.345 mA.

Error Mode is set to something other than "protective conductor ammeter mode"

Note

- Use this command after using the :SYSTEM:MODE command to set the protective conductor ammeter mode.

Queries the voltage measurement value

Syntax Query :MEASure:VOLTage?
Response <numerical value>
<numerical value> = Measurement value (NR3)

Function Query Returns the voltage measurement value as numeric values.(unit : V)

Example Query :MEASure:VOLTage?
Response :MEASURE:VOLTAGE +2.345E+00 (Headers : ON)
+2.345E+00 (Headers : OFF)
The voltage measurement value is 2.345 V

Error An execution error occurs when mode is set to something other than "voltmeter mode."

Queries the voltage measurement value

- Note**
- Use this command after executing the `:SYSTem:MODE` command to set the instrument into voltmeter mode.
 - When `[MEASure:VOLTage?]` command is transmitted before the appropriate measurement range is selected in the Auto range, there is the case that the right measurement value is not received by PC.

Deletes the saved data

- Syntax** Command `:MEMory:CLEar`
- Function** Command Deletes all saved measurement data from memory.
- Example** Command `:MEMory:CLEar`
Deletes all saved data.
- Error** An execution error occurs in the following cases:
- When the measurement mode is selected
 - When a mode other than "leakage current mode" is set

Queries the number of models in the saved data

- Syntax** Query `:MEMory:NUMBER?`
Response `<numerical value>`
`<numerical value> = 0 to 100 (NR1)`
- Function** Query Returns the number of models (total number of data units) in the saved data as a numeric value.
- Example** Query `:MEMory:NUMBER?`
Response `:MEMORY:NUMBER 10 (Headers: ON)`
`10 (Headers: OFF)`
Data on 10 models (data units) is saved.

Queries the equipment name/control number of the saved data

- Syntax** Query `:MEMory:READ:IDENTity? <numerical value>`
`<numerical value> = Data unit number(NR1)`
: Numeric value from 1 to the number of models (total number of data units)
- Response `<character value 1>,<character value 2>,<character value 3>`
`<character value 1> = Equipment name`
(text data with 1 to 12 characters)
`<character value 2> = Control number(text data with 1 to 12 characters)`
`<character value 3> = Date of last update`
- Function** Query Returns the equipment name, control number, and date of the last update of the specified data unit
See "To Transfer All Saved Data to a Computer" (p. 243)
- Example** Query `:MEMory:READ:IDENTity? 1`
Response `:MEMORY:READ:IDENTITY ABC,NO-111,2010/7/31`
(Headers: ON)
`ABC,NO-111,2010/7/31 (Headers: OFF)`
The equipment name, control number, and date of the last update of data unit 1 are "ABC," "NO-111," and "2010/7/31," respectively.

8.7 Command Message Description

Queries the equipment name/control number of the saved data

Error

If the set data unit number is greater than the total number of data units, an execution error occurs.

Reads saved data

Syntax	Query
	<pre> :MEMory:READ:MEASure? <numerical value>,<characters> <numerical value> = Data unit number (NR1) : Numeric value from 1 to the number of models (total number of data units) <characters> = Measurement mode EARTH/ENCLosure1(ENCL1)/ ENCLosure2(ENCL2)/ ENCLosure3(ENCL3)/PATient1(PAT1)/ PATient2(PAT2)/PATient3(PAT3)/PAUXiliary/ TOUCh1(TOUC1)/TOUCh2(TOUC2)/ TOUCh3(TOUC3)/PATientP2E(PATP2E)/ PATientSIPSOP(PATSIPSOP)/ PATientFTYPE(PATFTYPE)/PATientMP(PATMP)/ TPATientP2E(TPATP2E)/TPATientSIPSOP(TPATSIPSOP)/TPA- TientFTYPE(TPATFTYPE)/TPATientMP(TPATMP)/FREE </pre>
	<p>When network A, D, E, or F is selected</p> <pre> EARTH :Earth leakage current ENCLosure1 :Enclosure - Earth leakage current ENCLosure2 :Enclosure - Enclosure current ENCLosure3 :Enclosure - Line leakage current FREE :Free current (only network A) </pre>
	<p>When network B1 is selected(only ST5540)</p> <pre> EARTH :Earth leakage current ENCLosure1 :Enclosure - Earth leakage current ENCLosure2 :Enclosure - Enclosure current PATient1 :Patient leakage current I PATient2 :Patient leakage current II PATient3 :Patient leakage current III PAUXiliary :Patient auxiliary current FREE :Free current </pre>
	<p>When network C or G is selected</p> <pre> EARTH :Earth leakage current TOUCh1 :Touch current Enclosure - Earth TOUCh2 :Touch current Enclosure - Enclosure TOUCh3 :Touch current Enclosure - Line </pre>
	<p>When network B2 is selected(only ST5540)</p> <pre> EARTH :Earth leakage current TOUCh1 :Touch current Enclosure - Earth TOUCh2 :Touch current Enclosure - Enclosure PATAUXiliary :Patient auxiliary current PATientP2E :Patient leakage current Patient connection - Earth PATientSIPSOP :Patient leakage current SIP/SOP PATientFTYPE :Patient leakage current F-type applied part PATientMP :Patient leakage current Metal accessible part TPATientP2E :Total patient leakage current Applied part- Earth TPATientSIPSOP :Total patient leakage current SIP/SOP TPATientFTYPE :Total patient leakage current F-type applied part TPATientMP :Total patient leakage current Metal accessible part FREE :Free current </pre>

Reads saved data

Syntax	Response
	<p><numerical value 1>,<numerical value 2>,<numerical value 3>,<numerical value 4>,<numerical value 5>,<numerical value 6>,<numerical value 7>,<numerical value 8></p> <p><numerical value 1> = Maximum value (NR3) <numerical value 2> = Judgement (NR1)</p> <p>0 : Equal to or less than the allowable value (PASS) 1 : Greater than the allowable value (upper limit) (FAIL) 2 : Smaller than the allowable value (lower limit)(LOW) 3 : No judgment</p> <p><numerical value 3> = Power supply polarity (NR1)</p> <p>0 : Positive phase 1 : Negative phase (When the equipment under test is internally powered equipment, touch current (enclosure - line). When enclosure - line leakage current, the value is 0)</p> <p><numerical value 4> = Equipment under test status (NR1)</p> <p>0 : Normal condition 1 : Single-fault condition (Disconnection of one wire in power line) 2 : Single-fault condition (Disconnection of protective earth conductor) 3 : Single-fault condition (Application of 110% voltage: Positive phase) 4 : Single-fault condition (Application of 110% voltage: Negative phase) 5 : Single-fault condition (line voltage application: L) 6 : Single-fault condition (line voltage application: N)</p> <p><numerical value 5> = Measurement network filter (NR1)</p> <p>When network A is selected 0 : OFF, 1 : ON</p> <p>When network B1 or B2 is selected 0 : OFF, 1 : ON</p> <p>When network C is selected 0 : OFF, 2 : ON1(U2), 3 : ON2(U3), 4 : ON1(U1), 5 : ON2(U1)</p> <p>When network D, E, F or G is selected 0: OFF</p>

8.7 Command Message Description

Reads saved data

Syntax	Response	<p><numerical value 6> = Target current(NR1)</p> <p>0 : AC+DC 1 : AC 2 : DC 3 : ACPeak</p> <p><numerical value 7> =Other 110% voltage application</p> <p>0 : Application of 110% voltage : none 1 : Application of 110% voltage : Positive phase 2 : Application of 110% voltage : Negative phase (0 for ST5541)</p> <p><numerical value 8> =Specific 110% voltage application</p> <p>0 : Application of 110% voltage : none 1 : Application of 110% voltage : Positive phase 2 : Application of 110% voltage : Negative phase (0 for ST5541)</p> <p><numerical value 9> =Switch</p> <p>0 : S10=OFF, S12=OFF, S13=OFF 1 : S10=ON, S12=OFF, S13=OFF 2 : S10=OFF, S12=ON, S13=OFF 3 : S10=ON, S12=ON, S13=OFF 4 : S10=OFF, S12=OFF, S13=ON 5 : S10=ON, S12=OFF, S13=ON 6 : S10=OFF, S12=ON, S13=ON 7 : S10=ON, S12=ON, S13=ON (0 for ST5541)</p> <p>See "To Transfer All Saved Data to a Computer" (p. 243)</p>
Function	Query	<p>Returns the saved data of the designated measurement mode for the specified data unit.</p> <p>The data is arranged as follows: <1.Maximum value>, <2.Judgement>, <3.Power supply polarity>, <4.Equipment under test status>, <5.Measurement network filter>, <6.Target current>, <7.Other 110% voltage application>, <8.Specific 110% voltage application>, <9.Switch></p> <p>(unit of (1) maximum value : A)</p> <p>In all cases, data items (1) through (9) are repeated as many times as the number of data units.</p> <p>Returns only "0" when there is no saved data.</p>
Example	<p>Query</p> <p>Response</p>	<pre> :MEMory:READ:MEASURE? 1,ENCLOsure1 :MEMORY:READ:MEASURE +2.345E-03,0,0,0,1,0,0,0,0, +2.362E-03,0,1,0,1,0,0,0,0, +2.510E-03,0,0,2,1,0,0,0,0, +2.610E-03,1,1,2,1,0,0,0,0, +2.456E-03,0,0,1,1,0,0,0,0, +2.459E-03,0,1,1,1,0,0,0,0 (Headers : OFF) +2.345E-03,0,0,0,1,0,0,0,0, +2.362E-03,0,1,0,1,0,0,0,0, +2.510E-03,0,0,2,1,0,0,0,0, +2.610E-03,1,1,2,1,0,0,0,0, +2.456E-03,0,0,1,1,0,0,0,0, +2.459E-03,0,1,1,1,0,0,0,0 (Headers : ON) </pre> <p>The example of response data is shown below:</p>

Reads saved data

Maximum value	Judgment	Power supply polarity	Equipment under test status	Filter	Target current	Application of 110% of rated voltage under other conditions	Specific 110% voltage application	Switch
2.345 mA	PASS	Positive phase	Normal condition	ON	AC+DC	None	None	All Off
2.362 mA	PASS	Negative phase	Normal condition	ON	AC+DC	None	None	All Off
2.510 mA	PASS	Positive phase	Single-fault condition (Disconnection of protective earth conductor)	ON	AC+DC	None	None	All Off
2.610 mA	FAIL	Negative phase	Single-fault condition (Disconnection of protective earth conductor)	ON	AC+DC	None	None	All Off
2.456 mA	PASS	Positive phase	Single-fault condition (Disconnection of one wire in power line)	ON	AC+DC	None	None	All Off

Error

If the set data unit number is higher than the total number of data units, an execution error occurs.

Saves automatic measurement results

Syntax Command :MEMory:SAVE:AUTO

Function Command Saves automatic measurement results(date, Equipment name, Control number, Grounding class, Applied part, network, measurement mode, Maximum value, test condition setting at maximum value acquisition, judgement result)in memory.
*When network B1 or B2 is selected

Example Command :MEMory:SAVE:AUTO
Saves automatic measurement results.

Error

An execution error occurs in the following cases:

- When the measurement mode is not selected
- When a mode other than "leakage current mode" is set
- In automatic measurement
- When there is not enough memory space
- When there is not enough memory space
- When the equipment name and control number are the same as those of saved data, but the network, grounding class, and applied part differ
- When there is no data
- In manual measurement

Note

- Use this command after executing the :MODE command to activate the measurement mode.
- After automatic measurement, save data before starting the next automatic measurement.

8.7 Command Message Description

Saves the maximum value

Syntax	Command	:MEMory:SAVE:MAXimum
Function	Command	Saves the date, Equipment name, Control number, Grounding class, Applied part, network, measurement mode, Maximum value, test condition setting at maximum value acquisition, and judgement result of the present measurement in memory. *When network B1 or B2 is selected
Example	Command	:MEMory:SAVE:MAXimum Saves the maximum value.
Error		An execution error occurs in the following cases: <ul style="list-style-type: none"> • When the measurement mode is not selected • When a mode other than "leakage current mode" is set • In automatic measurement • When there is not enough memory space • When the equipment name and control number are the same as those of saved data, but the network, grounding class, and applied part differ • When there is no data
Note		Use this command after executing the :MODE command to activate the measurement mode.

Sets and queries the measurement mode

Syntax	Command	:MODE <characters>
	Query	:MODE?
	Response	<characters> <characters>=OFF/EARTh/ENCLosure1(ENCL1)/ENCLosure2(ENCL2)/ENCLosure3(ENCL3)/PATient1(PAT1)/PATient2(PAT2)/PATient3(PAT3)/PAUXiliary/TOUCh1(TOUC1)/TOUCh2(TOUC2)/TOUCh3(TOUC3)/PATientP2E(PATP2E)/PATientSIPSOP(PATSIPSOP)/PATientFTYPE(PATFTYPE)/PATientMP(PATMP)/TPATientP2E(TPATP2E)/TPATientSIPSOP(TPAT-SIPSOP)/TPATientFTYPE(TPATFTYPE)/TPATientMP(TPATMP)/FREE
		When network A, D, E, or F is selected
	OFF	: Mode not selected (Initial screen : command) (Initial screen, system screen : query)
	EARTh	: Earth leakage current
	ENCLosure1	: Enclosure - Earth leakage current
	ENCLosure2	: Enclosure - Enclosure current
	ENCLosure3	: Enclosure - Line leakage current
	FREE	: Free current (only network A)
		When network B1 is selected
	OFF	: Mode not selected (Initial screen : command) (Initial screen, system screen : query)
	ENCLosure1	: Enclosure - Earth leakage current
	ENCLosure2	: Enclosure - Enclosure current
	PATient1	: Patient leakage current I
	PATient2	: Patient leakage current II
	PATient3	: Patient leakage current III
	PAUXiliary	: Patient auxiliary current
	FREE	: Free current
		When network C or G is selected
	OFF	: Mode not selected (Initial screen: command) (Initial screen, system screen : query)
	EARTh	: Earth leakage current
	TOUCh1	: Touch current Enclosure - Earth
	TOUCh2	: Touch current Enclosure - Enclosure
	TOUCh3	: Touch current Enclosure - Line

8.7 Command Message Description

Sets and queries the measurement mode

	When network B2 is selected
OFF	: Mode not selected (Initial screen : command) (Initial screen, system screen: query)
EARTH	: Earth leakage current
TOUCH1	: Touch current Enclosure - Earth
TOUCH2	: Touch current Enclosure - Enclosure
PAUXiliary	: Patient auxiliary current
PATientP2E	: Patient auxiliary current Patient - Earth
PATientSIPSOP	: Patient leakage current SIP/SOP
PATientFTYPE	: Patient leakage current F-type applied part
PATientMP	: Patient leakage current Metal accessible part
TPATientP2E	: Total patient leakage current Applied part- Earth
TPATientSIPSOP	: Total patient leakage current SIP/SOP
TPATientFTYPE	: Total patient leakage current F-type applied part
TPATientMP	: Total patient leakage current Metal accessible part
FREE	: Free current

Function	Command	Sets the measurement mode and changes the screen.
	Query	Returns the measurement mode setting as alphabetic characters.

Example	Command	:MODE EARTH Sets Earth leakage current measurement mode.
	Query	:MODE?
	Response	:MODE EARTH (Headers : ON) EARTH (Headers : OFF) Earth leakage current measurement mode has been set.

Sets and queries the measurement mode

Error

An execution error occurs in the following cases:

- When a mode other than "leakage current mode" is set (Command)
- When network is OFF(Command)
- During automatic measurements(Command)
- When power on polarity switching is set and a power on check ends in an error (NG), it is the instrument that is causing the error.

- When network A, C, D, E, or F is selected
When Earth leakage current measurement mode is set for equipment under test whose grounding class is not Class I
When set to Patient leakage current I, Patient leakage current II, Patient leakage current III, Patient auxiliary current, Patient leakage current Patient connection - Earth, Patient leakage currentSIP/SOP, Patient leakage current F-type applied part, Patient leakage current Metal accessible part, Total patient leakage current Patient - Earth, Total patient leakage current SIP/SOP, Total patient leakage current F-type applied part, Total patient leakage current Metal accessible part mode
- When an attempt is made to set enclosure - line leakage current mode and touch current (Enclosure - Line) when the grounding class of equipment under test is internally powered equipment

- When network B1 is selected (only ST5540)
When Earth leakage current measurement mode is set for equipment under test whose grounding class is not Class I
When patient leakage current III mode is set for equipment under test whose applied part is set to Type B
When patient leakage current II mode is set for a Type BF or Type CF applied part
When Enclosure - Line leakage current is set

- When network B2 is selected(only ST5540)
When Earth leakage current measurement mode is set for equipment under test whose grounding class is not Class I
When an attempt is made to set patient leakage current F-type applied part or total patient leakage current F-type applied part for equipment under test whose applied part is set to a B-type applied part
When an attempt is made to set patient leakage current metal accessible part or total patient leakage current metal accessible part for a CF-type applied part

Sets and queries the network

Syntax	Command	:NETWork <characters>
	Query	:NETWork?
	Response	<characters> <characters> = A/ B2/ C/ D/ E/ F/ G/B1/OFF A: Network A B2: Network B2(only ST5540) C: Network C D: Network D E: Network E F: Network F G: Network G B1: Network B1(only ST5540) OFF: No network setting

8.7 Command Message Description

Sets and queries the network

Function	Command	Sets the network.
	Query	Returns the network setting as alphabetic characters.
Example	Command	<code>:NETWork A</code> Sets network A
	Query	<code>:NETWork?</code>
	Response	<code>:NETWORK A</code> (Headers : ON) <code>A</code> (Headers: OFF) Network A has been set.
Error		An execution error occurs in the following cases: <ul style="list-style-type: none"> • When the measurement mode is selected (Command) • When a mode other than "leakage current mode" is set (Command)
Note		Use this command after executing the <code>:MODE</code> command to activate OFF mode (i.e., measurement mode not selected).

Start of automatic measurement

Syntax	Command	<code>:START</code>
Function	Command	Starts measurement when automatic measurement is set.
Example	Command	<code>:CONFigure:AUTO ON;:START</code> Starts automatic measurement.
	Error	An execution error occurs in the following cases: <ul style="list-style-type: none"> • When the measurement method is set to "manual measurement" • When the measurement mode is not selected • When a mode other than "leakage current mode" is set • When polarity switching is set to power on setting and a power on check ends in an error (NG), it is the instrument that is causing the error. • When measurement time is set to 1 s. • For Touch current Enclosure - Line and Enclosure - Line leakage current, if the pre-check to prevent a ground fault results in NG judgement, an equipment-dependent error occurs.
Note		Use this command after executing the <code>:MODE</code> command to activate the measurement mode.

Stops automatic measurements

Syntax	Command	<code>:STOP</code>
Function	Command	Stops measurement when automatic measurement is set.
Example	Command	<code>:STOP</code> Stops automatic measurement.
	Error	An execution error occurs in the following cases : <ul style="list-style-type: none"> • When the measurement method is set to "manual measurement" • When the measurement mode is not selected • When a mode other than "leakage current mode" is set
Note		Use this command after executing the <code>:MODE</code> command to activate the measurement mode.

Sets and queries the backlight automatic OFF function

Syntax	Command : <code>SYSTEM:BACKlight <numerical value></code> Query : <code>SYSTEM:BACKlight?</code> Response : <code><numerical value></code> : <code><numerical value> = 0 to 30 (NR1)</code> 0 : Constant ON 1 to 30 : Auto OFF(1 to 30 minute)
Function	Command Sets the backlight automatic OFF function. Query Returns the setting of the backlight automatic OFF function as a numeric value.
Example	Command : <code>SYSTEM:BACKlight 5</code> Returns the setting of the backlight automatic OFF function as a numeric value. Query : <code>SYSTEM:BACKlight?</code> Response : <code>SYSTEM:BACKLIGHT 5 (Headers : ON)</code> : <code>5 (Headers : OFF)</code> The function has been set to 5 minutes.
Error	An execution error occurs in the following cases : <ul style="list-style-type: none"> • If the setting does not conform to the specified value range(Command) • When the measurement mode is selected (Command) • When a mode other than "leakage current mode" is set (Command)
Note	Use this command after executing the : <code>MODE</code> command to activate OFF mode (i.e., measurement mode not selected).

Sets and queries the beep sound (Judgement of allowable value)

Syntax	Command : <code>SYSTEM:BEEPer:COMParator <characters></code> Query : <code>SYSTEM:BEEPer:COMParator?</code> Response : <code><characters></code> : <code><characters> = FAIL/PASS/OFF</code> FAIL : Generates a beep sound for "FAIL" judgement. PASS : Generates a beep sound for "PASS" judgement OFF : Does not generate a beep sound.
Function	Command Sets the beep sound for notification of allowable value judgement. Query Returns the beep sound setting for notification of allowable value judgement.
Example	Command : <code>SYSTEM:BEEPer:COMParator FAIL</code> Sets the beep sound to be generated for "FAIL" judgement. Query : <code>SYSTEM:BEEPer:COMParator?</code> Response : <code>SYSTEM:BEEPER:COMPARATOR FAIL (Headers: ON)</code> : <code>FAIL (Headers: OFF)</code> The setting has been made to generate a beep sound for "FAIL" judgement.
Error	An execution error occurs in the following cases: <ul style="list-style-type: none"> • When the measurement mode is selected (Command) • When a mode other than "leakage current mode" is set (Command)
Note	Use this command after executing the : <code>MODE</code> command to activate OFF mode (i.e., measurement mode not selected).

8.7 Command Message Description

Sets and queries the beep sound (Key entry)

Syntax	Command	:SYSTem:BEEPer:KEY <characters>
	Query	:SYSTem:BEEPer:KEY?
	Response	<characters> <characters> = ON/OFF ON : Generates a beep sound. OFF:Does not generate a beep sound.
Function	Command	Sets the beep sound for notification of key entry.
	Query	Returns the beep sound setting for notification of key entry.
Example	Command	:SYSTem:BEEPer:KEY ON Sets the beep sound to ON.
	Query	:SYSTem:BEEPer:KEY?
	Response	:SYSTEM:BEEPER:KEY ON (Headers : ON) ON (Headers : OFF) The beep sound has been set to ON.
	Error	An execution error occurs in the following cases: <ul style="list-style-type: none"> • When the measurement mode is selected (Command) • When a mode other than "leakage current mode" is set (Command)
Note	Use this command after executing the :MODE command to activate OFF mode (i.e., measurement mode not selected).	

Sets and queries the beep sound (T2 output)

Syntax	Command	:SYSTem:BEEPer:T2OUT <characters>
	Query	:SYSTem:BEEPer:T2OUT?
	Response	<characters> <characters> = ON/OFF ON : Generates a beep sound. OFF:Does not generate a beep sound.
Function	Command	Sets the beep sound to be generated while line voltage is output from terminal 2.
	Query	Returns the beep sound setting for notification of line voltage output from terminal T2.
Example	Command	:SYSTem:BEEPer:T2OUT ON Sets the beep sound to ON.
	Query	:SYSTem:BEEPer:T2OUT?
	Response	:SYSTEM:BEEPER:T2OUT ON (Headers : ON) ON (Headers : OFF) The beep sound has been set to ON.
	Error	An execution error occurs in the following cases: <ul style="list-style-type: none"> • When the measurement mode is selected (Command) • When a mode other than "leakage current mode" is set (Command)
Note	Use this command after executing the :MODE command to activate OFF mode (i.e., measurement mode not selected).	

Sets and queries the beep sound (T3 output)

Syntax	Command	:SYSTem:BEEPer:T3OUt <characters>
	Query	:SYSTem:BEEPer:T3OUt?
	Response	<characters> <characters> = ON/OFF ON: Generates a beep sound. OFF :Does not generate a beep sound.
Function	Command	Sets the beep sound to be generated while 110% voltage is output from terminal 3.
	Query	Returns the beep sound setting for notification of 110% voltage output from terminal T3.
Example	Command	:SYSTem:BEEPer:T3OUt ON Sets the beep sound to ON.
	Query	:SYSTem:BEEPer:T3OUt?
	Response	:SYSTEM:BEEPER:T3OUT ON (Headers : ON) ON (Headers : OFF) The beep sound has been set to ON.
	Error	An execution error occurs in the following cases: <ul style="list-style-type: none"> • When the measurement mode is selected (Command) • When a mode other than "leakage current mode" is set (Command)
Note	Use this command after executing the :MODE command to activate OFF mode (i.e., measurement mode not selected).	

Clears the panel

Syntax	Command	:SYSTem:CLEAr
Function	Command	Initializes all test condition setting data including the contents of all panels.
Example	Command	:SYSTem:CLEAr Initializes all panels.
Error	An execution error occurs in the following cases : <ul style="list-style-type: none"> • When the measurement mode is selected • When a mode other than "leakage current mode" is set 	
Note	Use this command after executing the :MODE command to activate OFF mode (i.e., measurement mode not selected).	

Sets and queries the date

Syntax	Command	:SYSTem:DATE <numerical value 1>,<numerical value 2>,<numerical value 3>
	Query	:SYSTem:DATE?
	Response	<numerical value 1>,<numerical value 2>,<numerical value 3> <numerical value 1> = Year : 2000 to 2099 (NR1) <numerical value 2> = Month : 1 to 12 (NR1) <numerical value 3> = Day : 1 to 31 (NR1)

8.7 Command Message Description

Sets and queries the date

Function	Command	Sets the date in order of year, month, and day.
	Query	Returns the date setting as a numeric value.
Example	Command	<code>:SYSTem:DATE 2010,7,31</code> Sets the date to 2010, July 31.
	Query	<code>:SYSTem:DATE?</code>
	Response	<code>:SYSTEM:DATE 2010,7,31</code> (Headers : ON) <code>2010,7,31</code> (Headers : OFF) The date has been set to 2010, July 31.
	Error	An execution error occurs in the following cases: <ul style="list-style-type: none"> • When the measurement mode is selected (Command) • If the set numeric value is not within the specified range (Command) • When a mode other than "leakage current mode" is set (Command) • If the character string does not conform to the specified format (Command)
Note	Use this command after executing the <code>:MODE</code> command to activate OFF mode (i.e., measurement mode not selected).	

Queries the content of a panel

Syntax	Query	: SYSTem: FILE? <numerical value> <numerical value> = 1 to 30 (NR1)
	Response	<character value 1>,<character value 2>,<character value 3>,<character value 4>,<character value 5>, <numerical value 1>,<numerical value 2>,<numerical value 3>,<numerical value 4>,<numerical value 5>,<numerical value 6>... <character value 1> = Equipment name <character value 2> = Control number <character value 3> = Grounding class CLA1 : Class-I equipment CLA2 : Class-II equipment INT : Internally powered equipment <character value 4> = Applied part B : Type B applied part BF : Type BF applied part CF : Type CF applied part (Returns 0 for network A, C, D, E, F or G) <character value 5> = Network A : Network A B1 : Network B1(only ST5540) C : Network C D : Network D E : Network E F : Network F B2 : Network B2(only ST5540) G : Network G <numerical value 1> = Measurement mode When network A, D, E, or F is selected 0 : Earth leakage current 1 : Enclosure - Earth leakage current 2 : Enclosure - Enclosure current 3 : Enclosure - Line leakage current 19 : Free current (only network A) When network C or G is selected 0 : Earth leakage current 8 : Touch current Enclosure - Earth 9 : Touch current Enclosure - Enclosure 10 : Touch current Enclosure - Line When network B1 is selected(only ST5540) 0 : Earth leakage current 1 : Enclosure - Earth leakage current 2 : Enclosure - Enclosure current 4 : Patient leakage current I 5 : Patient leakage current II 6 : Patient leakage current III 7 : Patient auxiliary current 19 : Free current

8.7 Command Message Description

Queries the content of a panel

When network B2 is selected(only ST5540)

- 0 : Earth leakage current
- 7 : Patient auxiliary current
- 8 : Touch current Enclosure - Earth
- 9 : Touch current Enclosure - Enclosure
- 11 : Patient leakage current Patient connection - Earth
- 12 : Patient leakage current SIP/SOP
- 13 : Patient leakage current F-type applied part
- 14 : Patient leakage current Metal accessible part
- 15 : Total patient leakage current Patient - Earth
- 16 : Total patient leakage current SIP/SOP
- 17 : Total patient leakage current F-type applied part
- 18 : Total patient leakage current Metal accessible part
- 19 : Free current

<numerical value 2> = Measurement method

- 0 : Manual
- 1 : Automatic

<numerical value 3> = Target current

When network A is selected

- 0 : AC+DC, 1 : AC, 2 : DC,
- 3 : ACpeak (only Free current)

When network B1 is selected(only ST5540)

- 0 : AC+DC, 1 : AC, 2 : DC,
- 3 : ACpeak (only Free current)

(0 except for Patient leakage current I, Patient auxiliary current)

When network C, D, E, F or G is selected

- 0 : AC+DC, 1 : AC, 2 : DC, 3 : ACpeak

When network B2 is selected (only ST5540)

- 0 : AC+DC, 1 : AC, 2 : DC
- 3 : ACpeak (only Free current)

(0 except for Patient auxiliary current/Patient leakage current Patient connection - Earth, Patient leakage current SIP/SOP, Total patient leakage current Patient - Earth, Total patient leakage current SIP/SOP)

<numerical value 4> = Measurement range

AC, AC+DC, DC

- 0 : Auto range
- 1 : 50.00 mA range
- 2 : 5.000 mA range
- 3 : 500.0 μ A range
- 4 : 50.00 μ A range

ACpeak

- 0 : Auto range
- 1 : 100.0 mA range
- 2 : 10.00 mA range
- 3 : 1.000 mA range
- 4 : 500.0 μ A range

<numerical value 5> = Filter

When network A is selected

- 0 : OFF, 1 : ON

When network B1 or B2 is selected

- 0 : OFF, 1 : ON

When network C is selected

- 0 : OFF, 2 : ON1(U2), 3 : ON2(U3), 4 : ON1(U1), 5 : ON2(U1)

When network D, E, F or G is selected

- 0 : OFF

<numerical value 6> = Allowable value date in normal condition(NR3)(unit : A)

<numerical value 7> = Allowable value in Single-fault condition(NR3)(unit : A)

Queries the content of a panel

- * <numerical value 8> = Normal condition allowable value to use when making DC measurements(NR3)(unit : A)
- * <numerical value 9> = Single fault condition allowable value to use when making DC measurements(NR3)(unit : A)
- <numerical value 10> = Allowable value data for normal condition (lower limit)
On/Off
0 : OFF
1 : ON
- <numerical value 11> = Allowable value for single-fault condition (lower limit)
On/Off
0 : OFF
1 : ON
- * <numerical value 12> =Allowable value (lower limit) On/Off of normal condition during DC measurements
0 : OFF
1 : ON
- * <numerical value 13> =Allowable value (lower limit) On/Off of single fault condition during DC measurements
0 : OFF
1 : ON
- <numerical value 14> = Equipment under test status
0 : Normal condition
1 : Single-fault condition
(Disconnection of one wire in power line)
2 : Single-fault condition
(Disconnection of protective earth conductor)
3 : Single-fault condition
(Application of 110% voltage : Positive phase)
4 : Single-fault condition
(Application of 110% voltage : Negative phase)
5 : Single-fault condition (line voltage application : L)
6 : Single-fault condition (line voltage application : N)
- <numerical value 15> = Power supply polarity
0 : Positive phase
1 : Negative phase
(0 for the setting of equipment under test is internally powered equipment, Enclosure - Line leakage current, Touch current Enclosure - Line)
- <numerical value 16> = Other 110% voltage application
0 : Application of 110% voltage : none
1 : Application of 110% voltage : Positive phase
2 : Application of 110% voltage : Negative phase
(0 for ST5541)
- <numerical value 17> = Specific 110% voltage application
0 : Application of 110% voltage : none
1 : Application of 110% voltage : Positive phase
2 : Application of 110% voltage : Negative phase
(0 for ST5541)

8.7 Command Message Description

Queries the content of a panel

<numerical value 18> = Switch
 0 : S10=OFF, S12=OFF, S13=OFF
 1 : S10=ON, S12=OFF, S13=OFF
 2 : S10=OFF, S12=ON, S13=OFF
 3 : S10=ON, S12=ON, S13=OFF
 4 : S10=OFF, S12=OFF, S13=ON
 5 : S10=ON, S12=OFF, S13=ON
 (0 for ST5541)

<numerical value 19> = Measurement item in automatic measurement
 1 to 4095 (NR1)

128 bit 7	64 bit 6	32 bit 5	16 bit 4	8 bit 3	4 bit 2	2 bit 1	1 bit 0
Not used	Negative phase	Positive phase	Applica-tion of 110% voltage (Negative phase)	Applica-tion of 110% voltage (Positive phase)	Discon-nection of protective earth con-ductor	Discon-nection of one wire in power line	Normal

32768 bit 15	16384 bit 14	8192 bit 13	4096 bit 12	2048 bit 11	1024 bit 10	512 bit 9	256 bit 8
Not used	Not used	Not used	Not used	Applica-tion of line voltage N	Applica-tion of line voltage L	AC	DC

<numerical value 20> = Measurement item in automatic measurement2
 0 to 63(NR1)

128 bit 7	64 bit 6	32 bit 5	16 bit 4	8 bit 3	4 bit 2	2 bit 1	1 bit 0
Not used	Not used	Specific 110% volt-age appli-cation(Neg-ative phase)	Specific 110% volt-age appli-cation(Posi-tive phase)	Not used	Other Ap-plication of 110% voltage (Negative phase)	Other Applica-tion of 110% voltage (Positive phase)	Other Applica-tion of 110% voltage (none)

32768 bit 15	16384 bit 14	8192 bit 13	4096 bit 12	2048 bit 11	1024 bit 10	512 bit 9	256 bit 8
Not used	Not used	Not used	Not used	Not used	Not used	Not used	Not used

<numerical value 21> = Measuring time in automatic measurement (NR1)(unit : s)
 <numerical value 22> = Wait time in automatic measurement(delay a) (NR1)(unit : s)
 <numerical value 23> = Wait time in automatic measurement(delay b2) (NR1)(unit : s)
 <numerical value 24> = Wait time in automatic measurement(delay c) (NR1)(unit : s)
 <numerical value 25> = Wait time in automatic measurement(delay b1)

Queries the content of a panel

Function	Query	Returns the content of the panel of the specified number.
Example	Query	:SYSTem:FILE? 1
	Response	:SYSTEM:FILE ABC,NO-111,CLA1,BF,B2,12,0,2,0,1,+100.00E-06,+500.00E-06,+10.00E-06,+50.00E-06,0,0,1,0,1,1,2,0,1,0,0,0,0,0,0(Headers: ON) ABC,NO-111,CLA1,BF,B2,12,0,2,0,1,+100.00E-06,+500.00E-06,+10.00E-06,+50.00E-06,0,0,1,0,1,1,2,0,1,0,0,0,0,0,0 (Headers: OFF) The following settings have been made: <Equipment name> : ABC <Control number> : NO-111 <Grounding class> : Class-I equipment <Applied part> : BF-type applied parts <Network> : Network B2 <Measurement mode> : Patient leakage current:SIP/SOP <Measurement method> : Manual <Target current> : DC <Measurement range> : Auto range <Filter> : ON <Allowable value in normal condition (upper limit)> : 0.1 mA <Allowable value in single-fault condition (upper limit)> : 0.5 mA <Normal condition allowable value (upper limit, DC measurements)> : 0.01mA <Single fault-condition allowable value (upper limit, DC measurements)> : 0.05mA <Allowable value in normal condition (lower limit ON/OFF)> : OFF <Allowable value in single-fault condition (lower limit ON/OFF)> : OFF <Normal condition allowable value (lower limit ON/OFF, AC measurements)> : ON <Single fault-condition allowable value (lower limit ON/OFF, AC measurements)> : OFF <Equipment under test status> : Single-fault condition Disconnection of one wire in power line) <Power supply polarity> : Negative phase <Other 110% voltage application> : 110% voltage application: Negative phase <Specific 110% voltage application> : 110% voltage application:None <Switch> : S10=ON,S12=OFF,S13=OFF <Measurement item in automatic measurement> : None <Measurement item in automatic measurement2> : None <Measuring time in automatic measurement> : None <Wait time in automatic measurement(delay a)> : None <Wait time in automatic measurement(delay b2)> : None <Wait time in automatic measurement(delay c)> : None <Wait time in automatic measurement(delay b1)> : None
Error		If the designated panel number does not conform to the specified range, an execution error occurs.
Note		Returns 0 in the following cases: <ul style="list-style-type: none"> • <numerical value 11>(Equipment under test status)<numerical value 12>(Power supply polarity) in automatic measurement <numerical value 13>(Other 110% voltage application)<numerical value 14>(Specific 110% voltage application)<numerical value 15>(Switch) • <numerical value 16> to <numerical value 22> in manual measurement • When there is no data

8.7 Command Message Description

Sets and queries the panel name

Syntax	Command	:SYSTem:FILE:NAME <numerical value>,<characters>
	Query	:SYSTem:FILE:NAME? <numerical value> <numerical value>=1 to 30(NR1)
	Response	<characters> <characters>=panel name (Character data: 1 to 12 characters)
Function	Command	Sets the panel name of the specified number.
	Query	Returns the panel name setting of the specified number.
Example	Command	:SYSTem:FILE:NAME 1,ABC Sets the panel name of number 1 to "ABC."
	Query	:SYSTem:FILE:NAME? 1
	Response	:SYSTEM:FILE:NAME ABC (Headers: ON) ABC(Headers: OFF) The panel name is set to "ABC."
Error		If the designated panel number does not conform to the specified range, an execution error occurs. An execution error occurs when there is no data. (Command)
Note		Returns "0" when there is no data. (Query)

Sets and queries the frequency range

Syntax	Command	:SYSTem:FREQuency <characters>
	Query	:SYSTem:FREQuency?
	Response	<characters> <characters>=15HZ/0.1HZ 15HZ:from 15Hz 0.1HZ:from 0.1Hz
Function	Command	Sets the frequency range.
	Query	Returns the frequency range setting as alphabetic characters.
Example	Command	:SYSTem:FREQuency 15HZ Sets the frequency range from 15 Hz.
	Query	:SYSTem:FREQuency?
	Response	:SYSTEM:FREQUENCY 15HZ (Headers : ON) 15HZ (Headers : OFF) The frequency range has been set to from 15 Hz.
Error		An execution error occurs in the following cases : <ul style="list-style-type: none"> • When measurement mode is selected (Command) • When a mode other than "leakage current mode" is set (Command)
Note		Use this command after using the :MODE command to turn off (and no measurement mode is selected). Setting the frequency range to 0.1 Hz will activate the following settings. <ul style="list-style-type: none"> • Leakage current mode: When measured current is ACPeak, ACDC is used. In the AUTO range, HOLD3 is used. • Voltmeter mode: In AUTO range, HOLD3 is used. • Protective conductor ammeter mode: Frequency range setting is disabled and operation starts from a 15 Hz setting.

Sets and queries the display language

Syntax	Command : <code>SYSTem:LANGUage <characters></code> Query : <code>SYSTem:LANGUage?</code> Response <code><characters></code> <code><characters></code> = JAPanese/ ENGLISH JAPanese : Japanese language ENGLISH : English language
Function	Command Sets the display language. Query Returns the display language setting.
Example	Command : <code>SYSTem:LANGUage JAPanese</code> Sets the display language to Japanese. Query : <code>SYSTem:LANGUage?</code> Response : <code>SYSTEM:LANGUAGE JAPANESE</code> (Headers : ON) <code>JAPANESE</code> (Headers : OFF) The display language has been set to Japanese.
Error	An execution error occurs in the following cases : <ul style="list-style-type: none"> • When the measurement mode is selected (Command) • When a mode other than "leakage current mode" is set (Command)
Note	<ul style="list-style-type: none"> • Use this command after executing the <code>:MODE</code> command to activate OFF mode (i.e., measurement mode not selected).

Loads a panel

Syntax	Command : <code>SYSTem:LOAD <numerical value></code> <code><numerical value></code> = 1 to 30 (NR1)
Function	Command Loads (reads) the content of the panel of the specified number.
Example	Command : <code>SYSTem:LOAD 10</code> Loads the content of panel number 10.
Error	An execution error occurs in the following cases: <ul style="list-style-type: none"> • When the measurement mode is selected • If the designated panel number does not conform to the specified range • When the panel of the specified number is not stored • When a mode other than "leakage current mode" is set
Note	<ul style="list-style-type: none"> • Use this command after executing the <code>:MODE</code> command to activate OFF mode (i.e., measurement mode not selected). • When power on polarity switching is set and a power on check ends in an error (NG), it is the instrument that is causing the error.

Sets and queries all allowable values (lower limit) On/Off

Syntax	Command : <code>SYSTem:LOWer <characters></code> Query : <code>SYSTem:LOWer?</code> Response <code><characters></code> <code><characters></code> =OFF/ON OFF: All allowable values (lower limit) OFF ON: All allowable value (lower limit) ON
---------------	--

8.7 Command Message Description

Sets and queries all allowable values (lower limit) On/Off

Function	Command	Sets the allowable value (lower limit) to On/Off.
	Query	Returns all allowable value (lower limit) On/Off settings as alphabetic characters.
Example	Command	<code>:SYSTem:LOWer ON</code> Sets all allowable values (lower limit) On/Off to On.
	Query	<code>:SYSTem:LOWer?</code>
	Response	<code>:SYSTEM:LOWER ON</code> (Headers: ON) <code>ON</code> (Headers: OFF) All allowable values (lower limit) On/Off has been set to On.
Error		An execution error occurs in the following cases: <ul style="list-style-type: none"> • When measurement mode is selected (Command) • When a mode other than "leakage current mode" is set (Command)
Note		Use this command after using the <code>:MODE</code> command to turn off (and no measurement mode is selected). Turning On/Off an allowable value (lower limit) after all allowable values (lower limit) have been turned On/Off will not result in a query asking to turn On/Off all allowable values. Use the query command for turning an allowable value On or Off to check.

Sets and queries the coefficients for all allowable values (lower limit)

Syntax	Command	<code>:SYSTem:LOWer:COEFFicient <numerical value></code>
	Query	<code>:SYSTem:LOWer:COEFFicient?</code>
	Response	<code><numerical value></code> <code><numerical value>=5 to 99(NR1)</code>
Function	Command	Sets the coefficient for all allowable values (lower limit).
	Query	Returns the set coefficients for all allowable values (lower limit) as a numeric value.
Example	Command	<code>:SYSTem:LOWer:COEFFicient 10</code> Sets coefficients for all allowable values (lower limit) to 10%.
	Query	<code>:SYSTem:LOWer:COEFFicient?</code>
	Response	<code>:SYSTEM:LOWER:COEFFICIENT 10</code> (Headers: ON) <code>10</code> (Headers : OFF) Coefficient settings for all allowable values (lower limit) are set to 10%.
Error		An execution error occurs in the following cases : <ul style="list-style-type: none"> • When measurement mode is selected (Command) • When a mode other than "leakage current mode" is set(Command)
Note		<ul style="list-style-type: none"> • Use this command after using the <code>:MODE</code> command to turn off (and no measurement mode is selected). • The unit is [%]. Fractions are rounded up when 0.5 or greater and rounded off when less than 0.5.

Sets and queries the mode

Syntax	Command	:SYSTem:MODE <characters>
	Query	:SYSTem:MODE?
	Response	<characters> <characters> = LC/VOLT/PCC LC : Leakage current ammeter mode VOLT : Voltmeter mode PCC : Protective conductor ammeter mode
Function	Command	Sets the mode.Sets the mode.
	Query	Returns the mode setting.
Example	Command	:SYSTem:MODE LC Sets the mode to ammeter mode.
	Query	:SYSTem:MODE?
	Response	:SYSTEM:MODE LC (Headers : ON) LC (Headers : OFF) The mode has been set to ammeter mode.
Error		If the measurement mode has been selected, an execution error occurs. (Command)
Note		Use this command after executing the :MODE command to activate OFF mode (i.e., measurement mode not selected).

Sets and queries the polarity switching

Syntax	Command	:SYSTem:POLarity<characters>
	Query	:SYSTem:POLarity?
	Response	<characters> <characters>=PREVIOUS/NOINTERRUPT PREVIOUS : Earlier procedure NOINTERRUPT : Power on polarity switching
Function	Command	Sets polarity switching.
	Query	Returns the polarity switch setting as alphabetic characters.
Example	Command	:SYSTem:POLarity PREVIOUS Sets polarity switching to the earlier procedure.
	Query	:SYSTem:POLarity?
	Response	:SYSTEM:POLARITY PREVIOUS (Headers : ON) PREVIOUS (Headers : OFF) Polarity switching has been set to the earlier procedure.
Error		An execution error occurs in the following cases : <ul style="list-style-type: none"> • When measurement mode is selected (Command) • When a mode other than "leakage current mode" is set (Command)
Note		<ul style="list-style-type: none"> • Use this command after using the :MODE command to turn off (and no measurement mode is selected).

8.7 Command Message Description

Initializes the ST5540/ST5541

Syntax	Command	:SYSTem:RESet <characters> <characters> = ALL/ CONDition/ SAVEdata ALL :Initializes the instrument to the default settings (factory settings). (Same as *RST command) CONDition :Initializes the instrument to the default settings except for saved measurement data. SAVEdata :Initializes only the saved measurement data.
Function	Command	Initializes the HiTESTER. After initialization, the initial screen is displayed.
Example	Command	:SYSTem:RESet SAVEdata Initializes only the saved measurement data.
Note		The communication conditions are not initialized.

Saves a panel

Syntax	Command	:SYSTem:SAVE <numerical value> <numerical value> = 1 to 30 (NR1)
Function	Command	Saves (stores) the present settings in the panel of the specified number.
Example	Command	:SYSTem:SAVE 5 Saves setting data in panel number 5.
Error		An execution error occurs in the following cases : <ul style="list-style-type: none"> • When the measurement mode is not selected • If the designated panel number does not conform to the specified range • When a mode other than "leakage current mode" is set

Queries the fuse check

Syntax	Query	:SYSTem:TEST:FUSE?
	Response	<characters> <characters>=OK/NG OK: FUSE CHECK OK NG: FUSE CHECK NG
Function	Query	Performs a fuse check and returns the result as alphabetic characters.
Example	Query	:SYSTem:TEST:FUSE?
	Response	:SYSTEM:TEST:FUSE OK (Headers : ON) OK (Headers : OFF) The result of the fuse check is OK.
Error		An execution error occurs in the following cases : <ul style="list-style-type: none"> • When measurement mode is selected • When a mode other than "leakage current mode" is set
Note		<ul style="list-style-type: none"> • Use this command after using the :MODE command to turn off (and no measurement mode is selected).

Sets and queries the fuse check (At power on)

Syntax	Command	:SYSTem:TEST:FUSE:START <characters>
	Query	:SYSTem:TEST:FUSE:START?
	Response	<characters> <characters>=ON/OFF ON : Performs fuse check at power on. OFF : Does not perform fuse check at power on.
Function	Command	Sets fuse check at power on.
Example	Command	:SYSTem:TEST:FUSE:START ON Performs fuse check at power on.
	Query	:SYSTem:TEST:FUSE:START?
	Response	:SYSTEM:TEST:FUSE:START ON (Headers: ON) ON (Headers: OFF) Performs fuse check at power on.

Queries the relay check

Syntax	Query	:SYSTem:TEST:RELAy?
	Response	<characters> <characters>=OK/NG OK: RELAY CHECK OK NG: RELAY CHECK NG
Function	Query	Performs a relay check and returns the result as alphabetic characters.
Example	Query	:SYSTem:TEST:RELAy?
	Response	:SYSTEM:TEST:RELAy OK (Headers : ON) OK (Headers : OFF) The result of the relay check is OK.
Error		An execution error occurs in the following cases : <ul style="list-style-type: none"> • When measurement mode is selected • When a mode other than "leakage current mode" is set
Note		<ul style="list-style-type: none"> • Use this command after using the :MODE command to turn off (and no measurement mode is selected).

Sets and queries the relay check (At power on)

Syntax	Command	:SYSTem:TEST:RELAy:START <characters>
	Query	:SYSTem:TEST:RELAy:START?
	Response	<characters> <characters>=ON/OFF ON : Performs relay check at power on. OFF : Does not perform relay check at power on.
Function	Command	Sets fuse check at power on.

8.7 Command Message Description

Sets and queries the relay check (At power on)

Example Command : `SYSTem:TEST:RELAy:START ON`
 Performs relay check at power on.

Query : `SYSTem:TEST:RELAy:START?`

Response : `SYSTEM:TEST:RELAY:START ON` (Headers: ON)
`ON` (Headers: OFF)
 Performs relay check at power on.

Queries the VA check

Syntax Query : `SYSTem:TEST:VA?`

Response <numerical value 1>,<numerical value 2>,<numerical value 3>,<numerical value 4>,<numerical value 5>,<numerical value 6>
 <numerical value 1> = Voltage value(between L and N)(NR3)
 <numerical value 2> = Current value(NR3)
 <numerical value 3> = VA value(NR3)
 <numerical value 4> = Voltage value(between L and G)(NR3)
 <numerical value 5> = Voltage value(between N and G)(NR3)
 <numerical value 6> = Judgement(NR1)
 See the table below.

Function Query Conducts the VA check and returns the results.

Example Query : `SYSTem:TEST:VA?`

Response : `SYSTEM:TEST:VA +100.0E+00,+12.00E+00,`
`+1.200E+03,+100.0E+00,+0.000E+00,0` (Headers : ON)
`+100.0E+00,+12.00E+00,+1.200E+03,+100.0E+00,+0.000E+00,0` (Headers : OFF)

The results of the VA check are as follows :

<Voltage value> : 100.0 V(between L and N)
 <Current value> : 12.0 A
 <VA value> : 1200 VA
 <Voltage value> : 100.0 V(between L and G)
 <Voltage value> : 0.0 V(between N and G)
 <Judgement> : No error

128 bit 7	64 bit 6	32 bit 5	16 bit 4	8 bit 3	4 bit 2	2 bit 1	1 bit 0
Not used	Not used	Not used	Reverse polarity	Grounding error	VA error	Current error	Voltage error

Error An execution error occurs in the following cases :

- When the measurement mode is selected
- When a mode other than "leakage current mode" is set

Note • Use this command after executing the : MODE command to activate OFF mode (i.e., measurement mode not selected).
 • When data displayed by the instrument is "less than 0.5A," the largest value that is less than the numeric value of the data is returned.
 • When the voltage is less than 80.0 V, +9.999E+09 is returned as the VA value, voltage (between L and G), and voltage (between N and G).

Sets and queries the VA check (At power on)

Syntax	Command	:SYSTem:TEST:VA:START <characters>
	Query	:SYSTem:TEST:VA:START?
	Response	<characters> <characters>=ON/OFF ON : Performs VA check at power on. OFF : Does not perform VA check at power on.
Function	Command	Sets VA check at power on.
Example	Command	:SYSTem:TEST:VA:START ON Performs VA check at power on.
	Query	:SYSTem:TEST:VA:START?
	Response	:SYSTEM:TEST:VA:START ON (Headers: ON) ON (Headers: OFF) Performs VA check at power on.

Sets and queries the time

Syntax	Command	:SYSTem:TIME <numerical value 1>,<numerical value 2>
	Query	:SYSTem:TIME?
	Response	<numerical value 1>,<numerical value 2> <numerical value 1> = Time 0 to 23 (NR1) <numerical value 2> = Minute 0 to 59 (NR1)
Function	Command	Sets the time in order of hours and minutes.
	Query	Returns the time setting in numeric values.
Example	Command	:SYSTem:TIME 12,34 Sets the time to 12:34.
	Query	:SYSTem:TIME?
	Response	:SYSTEM:TIME 12,34 (Headers : ON) 12,34 (Headers : OFF) The time has been set to 12:34.
Error		An execution error occurs in the following cases : <ul style="list-style-type: none"> • When the measurement mode is selected (Command) • If the set numeric value is not within the specified range (Command) • When a mode other than "leakage current mode" is set (Command) • If the character string does not conform to the specified format (Command)
Note		Use this command after executing the :MODE command to activate OFF mode (i.e., measurement mode not selected).

8.7 Command Message Description

Sets and queries the unit of current measurement

Syntax	Command :SYSTem:UNIT <characters> Query :SYSTem:UNIT? Response <characters> <characters> = AUTO/HOLD AUTO : Automatic HOLD : mA, fixed
Function	Command Sets the unit of current measurement. Query Returns the unit of current measurement setting.
Example	Command :SYSTem: UNIT AUTO Sets the unit of current measurement to Auto. Query :SYSTem:UNIT? Response :SYSTEM:UNIT AUTO (Headers : ON) AUTO (Headers : OFF) Auto has been set.
Error	An execution error occurs in the following cases : <ul style="list-style-type: none"> • When the measurement mode is selected (Command) • When a mode other than "leakage current mode" is set
Note	Use this command after executing the :MODE command to activate OFF mode (i.e., measurement mode not selected).

8.8 To Transfer All Saved Data to a Computer

1. Transmit `:MEMory:NUMBer?` to read the number of models (total number of data units).
2. Transmit `:MEMory:READ:IDENTity? <data unit number>` to read the equipment name and control number of the specified data unit.
 1. Transmit `:MEMory:READ:MEASure? <data unit number>, <measurement mode>` to read the saved data of the designated measurement mode for the specified data unit.
If only "0" is received as data, there is no saved data for that mode.
 2. Step (1) above is repeated as many times as the number of specified measurement modes.
3. When there are two or more models (total number of data units), the process in step 2. above is repeated.

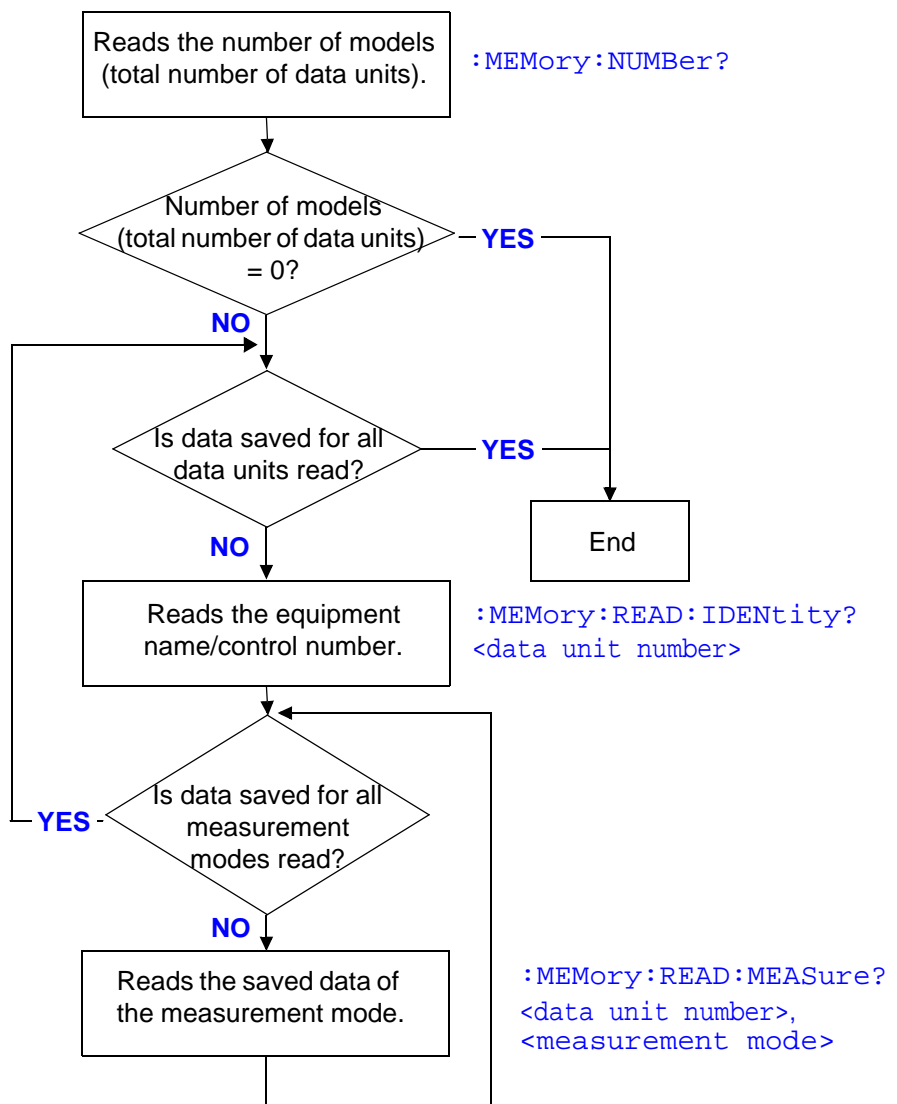

8.9 Troubleshooting

When the HiTESTER is malfunctioning, attempt checking and troubleshooting according to the instructions shown below.

Symptom	Cause / Treatment
The RS-232C/ USB has stopped working completely.	<ul style="list-style-type: none"> • Are the cables properly connected? • Are all the devices powered on? • Are correct cables used? • Has the communication condition been correctly set?
Communication failure with RS-232C/USB	<ul style="list-style-type: none"> • Does the RS-232C have the same settings (baud rate, data length, parity, stop bit)? <p>See "Message Terminators" (p. 148)</p>
After transmission on the RS-232C/ USB bus, the keys on the HiTESTER freeze up and have no effect.	<ul style="list-style-type: none"> • Press the LOCAL key on the front panel of the HiTESTER to release the remote state.
When attempting to read data using a BASIC INPUT statement, the RS-232C bus hangs.	<ul style="list-style-type: none"> • Be sure to transmit one query before each INPUT statement. • Have any of these transmitted queries resulted in an error?
The RS-232C/ USB has stopped working completely.	<ul style="list-style-type: none"> • Using the <code>*ESR?</code> query, inspect the standard event status register, and check what type of error has occurred.
Sending several queries, produces only one response.	<ul style="list-style-type: none"> • Has an error occurred? • Send the queries one at a time, and read the responses individually. When you want to read them in all at once, try doing so by putting them all on one line separated by the message separator character
The response message to a query differs from the display on the front panel.	<ul style="list-style-type: none"> • Due to the response message being produced at the instant that the HiTESTER receives the query, there is a possibility that it may not agree with the display at the instant that the controller reads it in.

External Control Chapter 9

Make a connection to the EXT I/O connector to perform external control.

- (1) EXT I/O terminal functions
 - Input of start/stop signals
 - Selection of panel number for data loading
 - Output of measurement end signal
 - Output of comparator judgement signal
 - Others
- (2) Connector type
 - 57RE-40360-730B(D29)-FA (manufactured by DDK)
- (3) Mating connector
 - 57F-30360-20S (manufactured by DDK)
 - RC30-36P(50) (manufactured by Hirose Electric) or equivalent instrument (to be procured by the user)

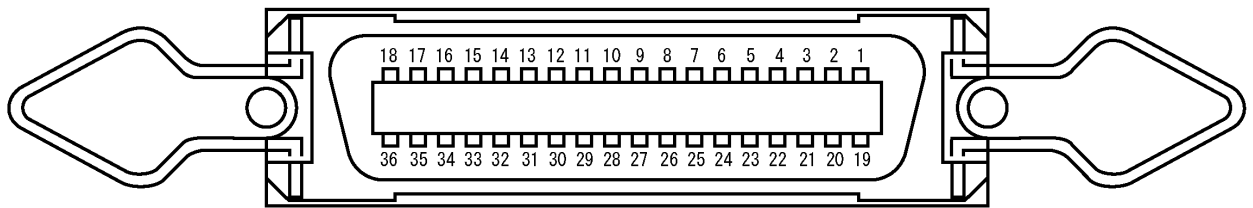

⚠ EXT I/O

EXT I/O connector pin layout (on main instrument)

9.1 Description of Signals

WARNING

To prevent electrical hazards, observe the following cautions:

- Turn off the instrument's power switch before connecting a cable to the terminal. Ensure secure connection to prevent the cable from disconnecting during operation and contacting a conductive part (e.g., chassis, test leads).
- Note that INT.GND is grounded. Therefore, electric potential in the controller may result in short-circuiting and cause an electrical hazard.

CAUTION

To prevent damage to the instrument, observe the following cautions:

- Do not input voltage or current exceeding the rating to the EXT I/O terminal.
- When using a relay, be sure to install a diode for absorbing counter-electromotive force.
- Do not short-circuit between the input and output terminals in the EXT I/O.
- Do not short-circuit between INT.DCV and INT.GND.
- Be sure to ground the equipment connected to the EXT I/O terminal. Failure to provide protective earthing may damage the insulation of the measurement system.
- The EXT I/O terminal is operable only when the measurement screen is displayed.

Pin No.	Input/output	Signal line name	Pin No.	Input/output	Signal line name
1	Input	$\overline{\text{START}}$	19	-	(Reserved)
2	Input	$\overline{\text{STOP}}$	20	Input	$\overline{\text{KEYLOCK}}$
3	-	(Reserved)	21	Input	$\overline{\text{LOAD0}}$
4	Input	$\overline{\text{LOAD1}}$	22	Input	$\overline{\text{LOAD2}}$
5	Input	$\overline{\text{LOAD3}}$	23	Input	$\overline{\text{LOAD4}}$
6	-	(Reserved)	24	-	(Reserved)
7	Output	$\overline{\text{TEST}}$	25	Output	$\overline{\text{MEAS}}$
8	Output	$\overline{\text{PASS}}$	26	Output	$\overline{\text{FAIL}}$
9	Output	$\overline{\text{T-FAIL}}$	27	Output	$\overline{\text{LOW}}$
10	-	(Reserved)	28	-	(Reserved)
11	Input	EXT.DCV	29	Output	INT.DCV
12	Input	EXT.DCV	30	Output	INT.DCV
13	Input	EXT.DCV	31	Output	INT.DCV
14	Input	EXT.DCV	32	Output	INT.DCV
15	Input	EXT.COM	33	Output	INT.GND
16	Input	EXT.COM	34	Output	INT.GND
17	Input	EXT.COM	35	Output	INT.GND
18	Input	EXT.COM	36	Output	INT.GND

9.2 Connecting to the EXT I/O Terminal

CAUTION

Connect an EXT I/O cable connector before turning on the instrument's power switch. Connecting or disconnecting a cable connector after turning the instrument on may cause a fault.

Follow the procedure described below when connecting an EXT I/O cable connector.

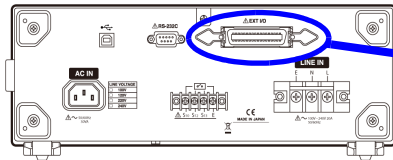

1. Connect an EXT I/O cable connector to the EXT I/O terminal of the main instrument.
2. Use the tabs of the EXT I/O terminal to lock the EXT I/O connector in place.

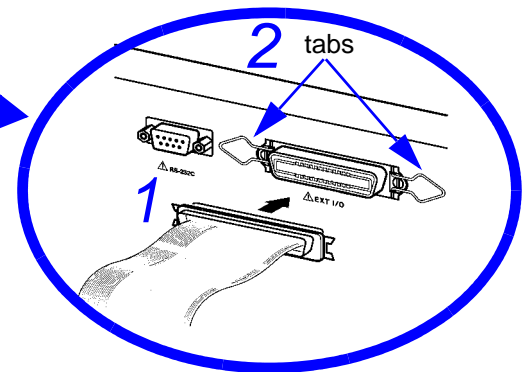

Terminal name	Input/output	Function
$\overline{\text{START}}$	Input	Sets the instrument to automatic measurement mode. When this terminal is set to Low level, automatic measurement starts. When LOAD0 to LOAD4 are set with this terminal set to Low level, the selected panel number is read and measurement starts.
$\overline{\text{STOP}}$	Input	During automatic measurement with this terminal set to Low level, the measurement ends (interrupted).
$\overline{\text{KEYLOCK}}$	Input	When this terminal is set to Low level, the key lock function is activated. Only Start , Stop and Apply on the touch panel are effective.
$\overline{\text{LOAD0}}$ to $\overline{\text{LOAD4}}$	Input	Selects the number of the panel to be loaded. When the START signal is input, the panel of the selected number is read and measurement starts. Negative-logic binary numbers are input to LOAD4 through LOAD0. MSB is input to LOAD4, and LSB to LOAD0.
$\overline{\text{TEST}}$	Output	When automatic measurement starts, the terminal changes to Low level and holds the level until all measurements are completed.
$\overline{\text{MEAS}}$	Output	During automatic measurement, this terminal outputs Low level for each measurement item.
$\overline{\text{PASS}}$	Output	During automatic measurement, this terminal changes to Low level when the allowable value judgement for each measurement value results in PASS.
$\overline{\text{FAIL}}$	Output	During automatic measurement, this terminal changes to Low level when the allowable value (upper limit value) judgement for each measurement value results in FAIL. It also changes to low level when a noninterrupted performance check or pre-check returns a FAIL result.
$\overline{\text{LOW}}$	Output	During automatic measurement, this terminal changes to Low level when a measurement value for an item drops below an allowable value (lower limit) (and LOW appears). It also changes to low level when a noninterrupted performance check or pre-check returns a FAIL result.
$\overline{\text{T-FAIL}}$	Output	During automatic measurement, this terminal changes to Low level when the allowable value judgement results in FAIL even once for any measurement item. It also changes to low level when a noninterrupted performance check returns a FAIL result.

9.2 Connecting to the EXT I/O Terminal

Terminal name	Input/output	Function
INT.DCV INT.GND	Output	Outputs the instrument's internal 5 VDC and GND.
EXT.DCV EXT.COM	Input	Terminal for power input from external equipment Allowed input voltage range: +5 to +24 VDC
(Reserved)	-	Do not use this terminal.

Table of $\overline{\text{LOAD0}}$ - $\overline{\text{LOAD4}}$ control and corresponding panel numbers

Number of panel to be loaded	LOAD4	LOAD3	LOAD2	LOAD1	LOAD0
1	1	1	1	1	0
2	1	1	1	0	1
3	1	1	1	0	0
4	1	1	0	1	1
5	1	1	0	1	0
6	1	1	0	0	1
7	1	1	0	0	0
8	1	0	1	1	1
9	1	0	1	1	0
10	1	0	1	0	1
11	1	0	1	0	0
12	1	0	0	1	1
13	1	0	0	1	0
14	1	0	0	0	1
15	1	0	0	0	0
16	0	1	1	1	1
17	0	1	1	1	0
18	0	1	1	0	1
19	0	1	1	0	0
20	0	1	0	1	1
21	0	1	0	1	0
22	0	1	0	0	1
23	0	1	0	0	0
24	0	0	1	1	1
25	0	0	1	1	0
26	0	0	1	0	1
27	0	0	1	0	0
28	0	0	0	1	1
29	0	0	0	1	0
30	0	0	0	0	1

1:High level, 2:Low level

NOTE

Invalid setting results when all terminals from $\overline{\text{LOAD0}}$ to $\overline{\text{LOAD4}}$ are set to "1" or "0."

9.3 Electrical Specifications

Input signal specifications

(Names of applicable signals : $\overline{\text{START}}$, $\overline{\text{STOP}}$, $\overline{\text{LOAD0}}$ to $\overline{\text{LOAD4}}$, $\overline{\text{KEYLOCK}}$)

Input signal	Active Low input
Maximum applied voltage	Input voltage to EXT.DCV terminal
High level	Input voltage to EXT.DCV terminal, or open
Low level	0.3 VDC or lower

Output signal specifications

(Names of applicable signals : $\overline{\text{TEST}}$, $\overline{\text{MEAS}}$, $\overline{\text{PASS}}$, $\overline{\text{U-FAIL}}$, $\overline{\text{L-FAIL}}$, $\overline{\text{T-FAIL}}$)

Output signal	Open collector output
Maximum load voltage	24 VDC (when not using EXT.DCV terminal)
Maximum output current	60 mA DC/1 signal (at Low level)

Maximum input voltage to EXT.DCV terminal : 24 VDC to EXT.COM terminal

Internal power supply output (between INT.DCV and INT.GND terminals)

Output voltage	5 VDC
Maximum load current	100 mA DC

The output signal is open collector output from the photocoupler.

Inside the instrument, the photocoupler is connected to the EXT.DCV terminal with a 1.0 k Ω pull-up resistor.

When not using the EXT.DCV terminal

When a load is directly connected to the output terminal without using the EXT.DCV terminal, the following relationship should exist among the external DC power supply voltage (connected to the other end of the load), output signal voltage, and current flowing to the output terminal.

External DC power supply	Output signal voltage			
	High level	Low level		
		10 mA output current	40 mA output current	60 mA output current (max.)
5 V	5 V	0.9 V	1.1 V	1.2 V
12 V	12 V	0.9 V	1.1 V	1.2 V
24 V	24 V	0.9 V	1.1 V	1.2 V

9.4 Internal Circuit Configuration

CAUTION

- Insulating the signal wires prevents signal interference. Be sure to ground external equipment connected to the instrument. If protective earthing is not provided, insulation damage may result.
- The maximum Low-level output current of the output photocoupler is 50 mA. If current higher than 50 mA is required, connect an external current amplification transistor circuit that operates on an external power supply.

The following shows the EXT I/O terminal circuit configuration.

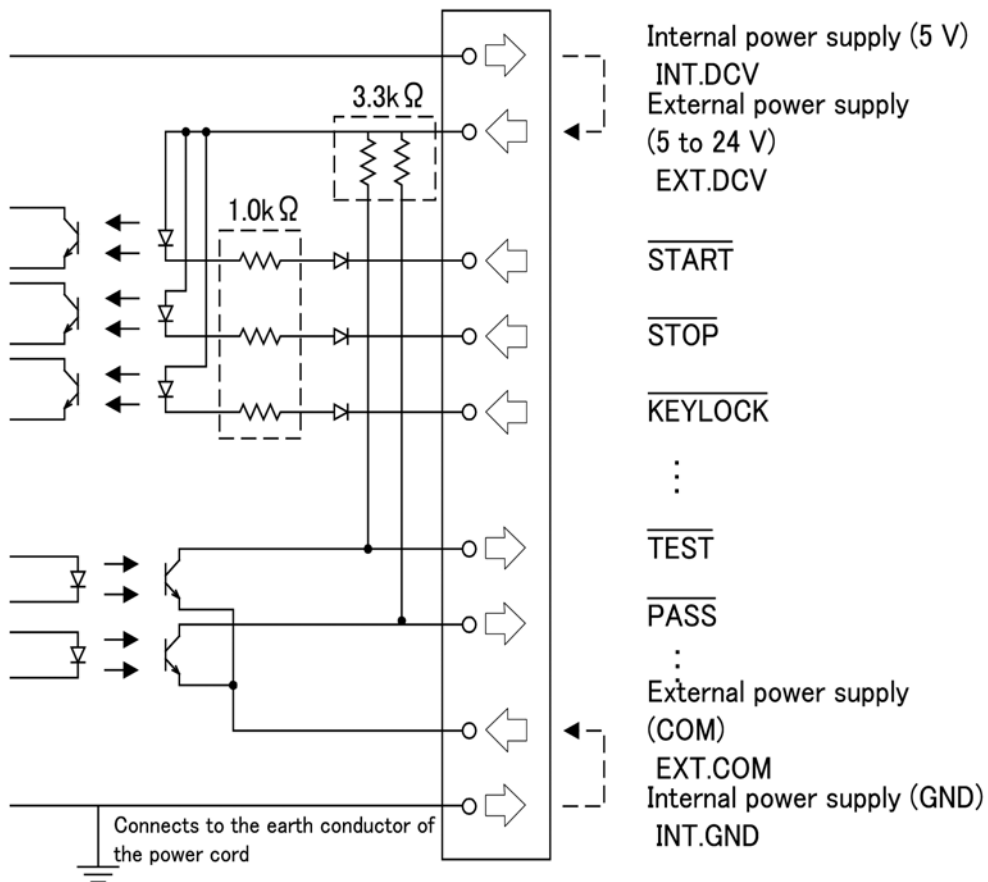

9.5 Timing Chart

This is a timing chart for output signals during manual measurements.

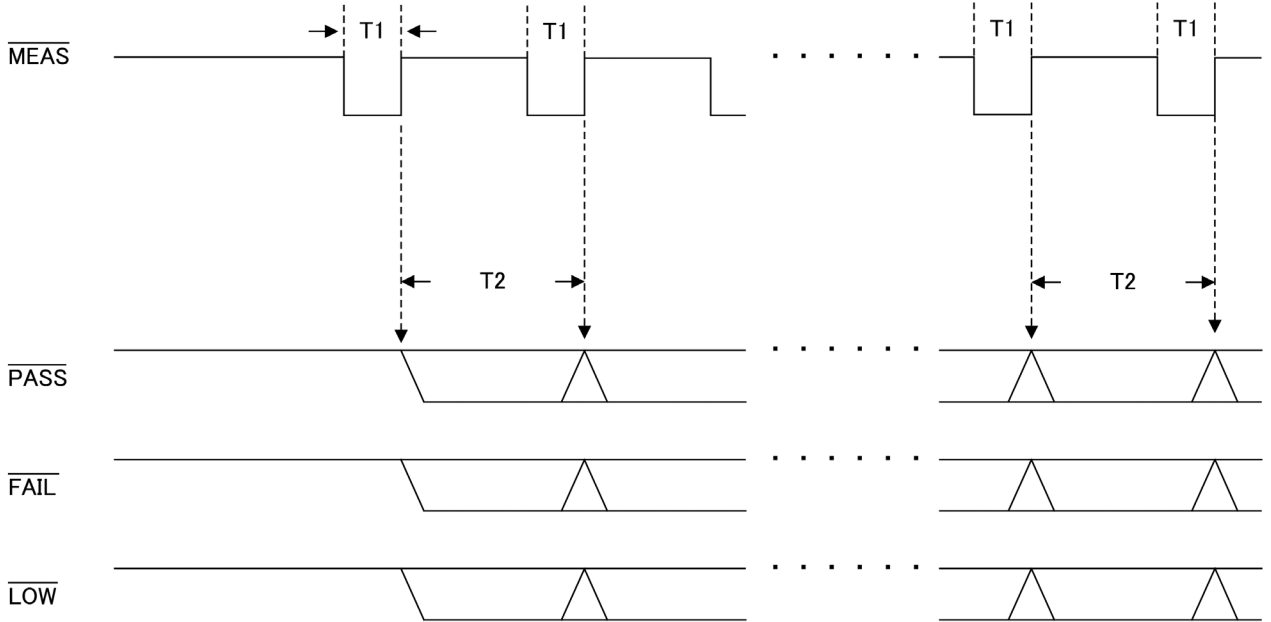

Description		Time	
		MIN	MAX
T1	Pulse width of measured signal	55ms	–
T2	Judgment result output time, display update time	Other than ACpeak:550ms	–
		ACpeak:600ms	–

NOTE

- Free run measurements are made while in the leakage current measurement screen.
- Calibration is performed once a minute. Measurements are temporarily halted during calibration. (The MEAS signal goes HI)

9.5 Timing Chart

The following shows the output signal timing chart for automatic measurement.
 The number of measurement items (n) varies depending on [number of polarity conditions] x [number of equipment status] set with **1** displayed on the automatic measurement setting screen.

(Example)

Polarity : Positive polarity ON, negative polarity ON.....2

Equipment status : Normal condition ON,
 earth conductor disconnection ON2

With the above settings, the number of measurement items (n) is 4 (2 x 2 = 4).

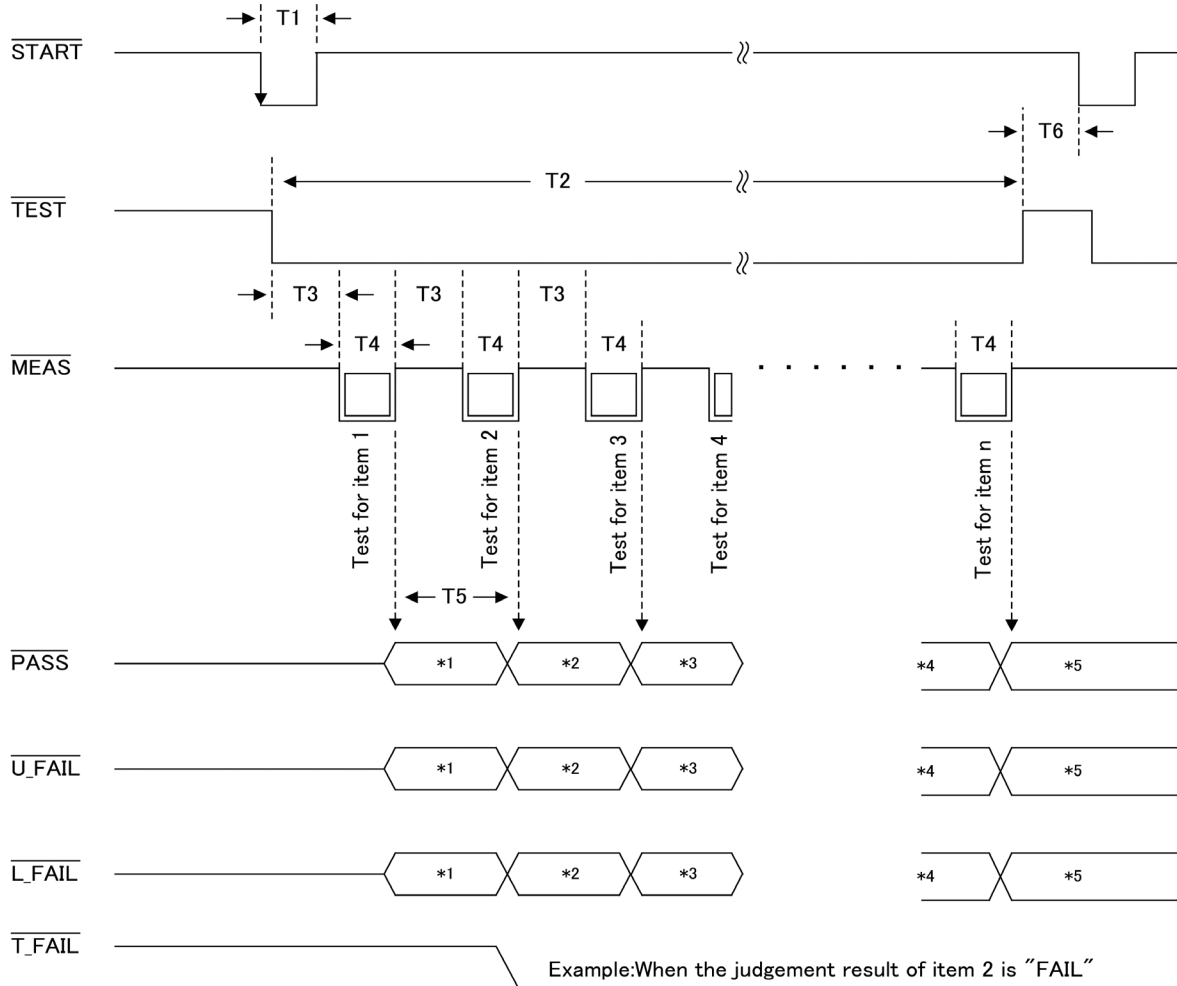

- *1 : Judgement result of item 1
- *2 : Judgement result of item 2
- *3 : Judgement result of item 3
- *4 : Judgement result of item (n - 1)
- *5 : Judgement result of item n

Description	Time	
	MIN	MAX
T1 Measurement start signal pulse width	1 ms	-
T2 Automatic measurement time	2 s	(T3 + T4) x number of measurement items
T3 Wait time between setting items	1 s	According to measurement delay setting for automatic measurement
T4 Measuring time of each setting item	1 s	According to measuring time setting for automatic measurement

Description	Time	
	MIN	MAX
T5 Judgement result output time	2 s	Until measurement completion of next measurement item
T6 Time from the completion of automatic measurement to next measurement start signal input	0 ms	-

Panel load function at EXT I/O start

Saved measurement conditions can be read and measurement conducted according to the conditions read.

The number of the panel to be read is specified by $\overline{LOAD0}$ through $\overline{LOAD4}$ before \overline{START} signal input.

See "Table of $\overline{LOAD0}$ - $\overline{LOAD4}$ control and corresponding panel numbers" (p. 248)

\overline{TEST} , \overline{PASS} , $\overline{U-FAIL}$, $\overline{L-FAIL}$ and $\overline{T-FAIL}$ are only output in automatic measurement.

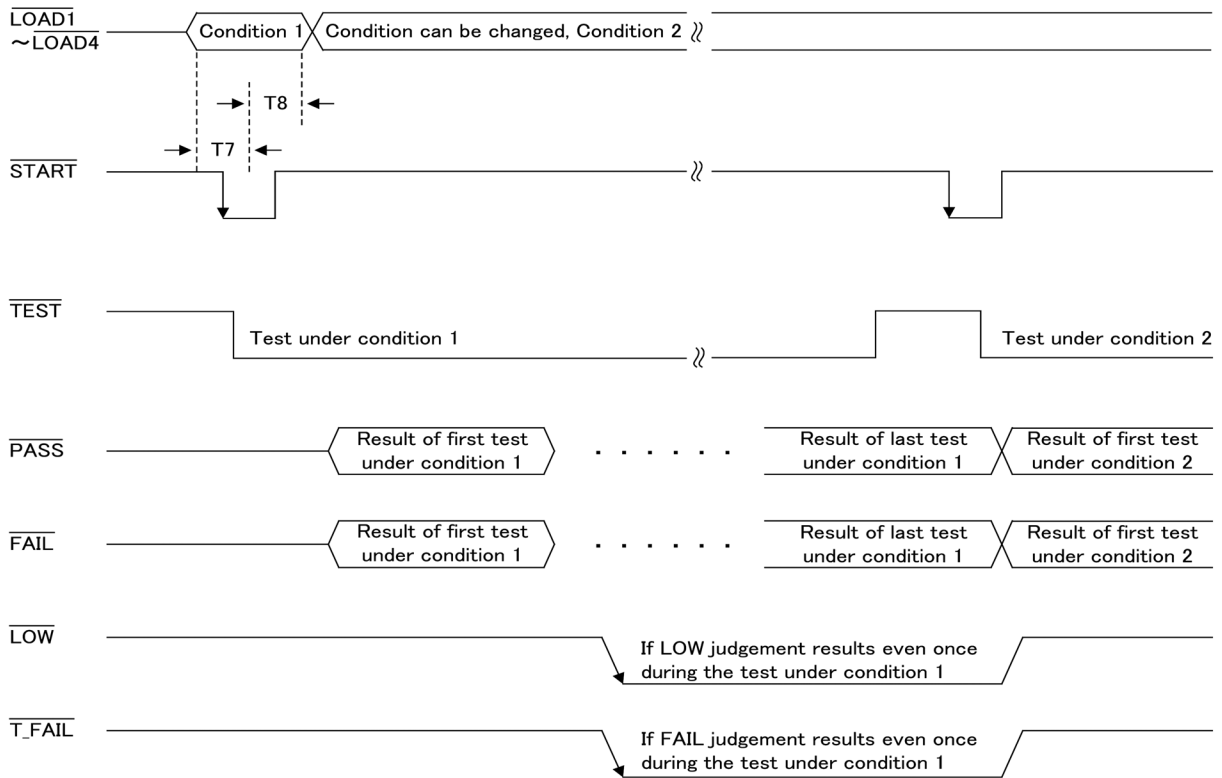

Description	Time		Explanation
	MIN	MAX	
T7 From setting $\overline{LOAD0}$ to $\overline{LOAD4}$ to \overline{START} input	1 ms		Low level must be held for at least 1 ms before starting.
T8 From \overline{START} input to changing the condition in $\overline{LOAD0}$ to $\overline{LOAD4}$ (change of condition for next measurement)	1 ms		After \overline{START} signal input, the panel load condition must be held for at least 1 ms.
T9 From completion of automatic measurement to next \overline{START} input	0 ms		When the condition is the same as T6, but the panel to be loaded is changed for measurement, it is necessary to change $\overline{LOAD0}$ to $\overline{LOAD4}$ in advance.

9.6 Example of Output Signal Connection

(1) When not using the INT.DCV, INT.GND, and EXT.DCV terminals

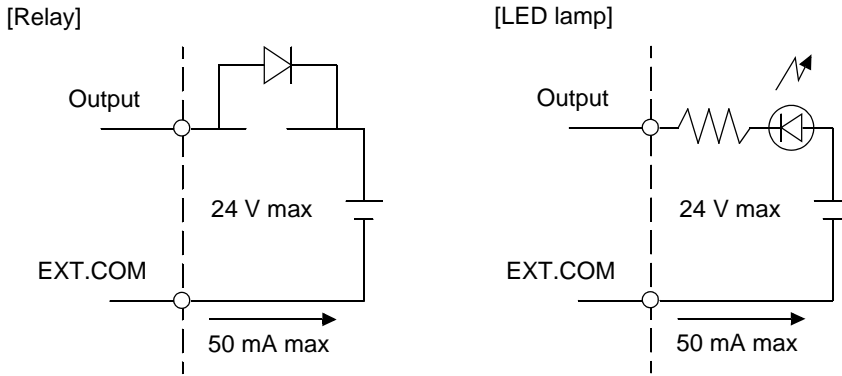

NOTE

When using a relay, be sure to install a diode for absorbing counter-electromotive force.

(2) When using the EXT.DCV and EXT.COM terminals

High (5 to 24 VDC) and Low signals can be obtained.

[Connection of negative-logic output]

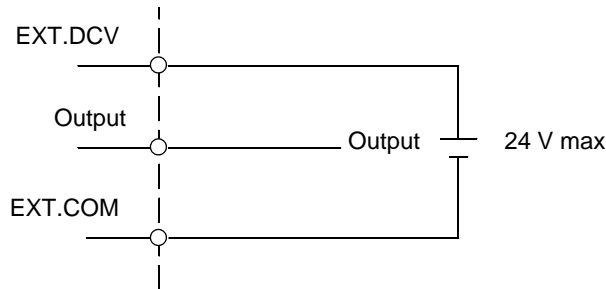

(3) When INT.DCV and EXT.DCV, and INT.GND and EXT.COM are short-circuited

High (5 VDC) and Low signals are obtained, respectively.

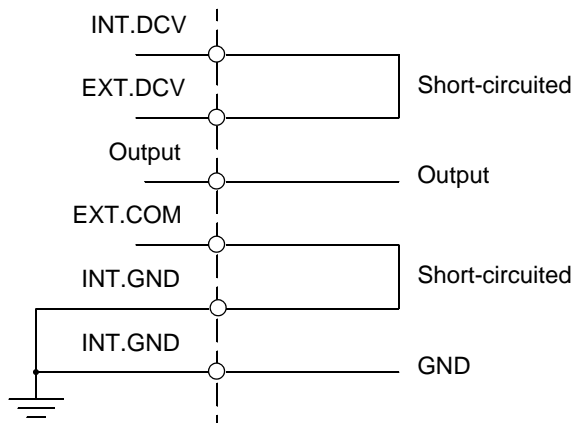

Specifications

Chapter 10

10.1 Basic Functions

Measurement mode	1: Earth leakage current	network A to G
	2: Touch current (Enclosure - Line)	network C, G
	3: Touch current (Enclosure - Earth)	network B2, C ,G
	4: Touch current (Enclosure - Enclosure)	network B2, C ,G
	5: Patient leakage current (Patient connection - Earth)*	network B2
	6: Patient leakage current (external voltage on a SIP/SOP)*	network B2
	7: Patient leakage current (external voltage on a specific F-type applied part)*	network B2
	8: Patient leakage current (current generated by external voltage from patient connections)*	network B2
	9: Patient auxiliary current*	network B1, B2
	10: Total patient leakage current (Patient connection - Earth)*	network B2
	11: Total patient leakage current (external voltage on a SIP/SOP)*	network B2
	12: Total patient leakage current (external voltage on a specific F-type applied part)*	network B2
	13: Total patient leakage current (current generated by external voltage from patient connections)*	network B2
	14: Free current measurement (Enclosure - Enclosure)	network A, B1, B2
	15: Enclosure - Earth leakage current	network A, B1, D, E, F
	16: Enclosure - enclosure leakage current	network A, B1, D, E, F
	17: Enclosure - line leakage current	network A, B1, D, E, F
	18: Patient leakage current I*	network B1
	19: Patient leakage current II*	network B1
	20: Patient leakage current III*	network B1
Target current	DC, AC, AC+DC, ACpeak	
Measurement range	(DC, AC, AC+DC)	50 mA, 5 mA, 500 μ A, 50 μ A range
	(ACPeak)	75 mA, 10 mA, 1 mA, 500 μ A range
Range switch	AUTO(default), HOLD	

10.2 Auxiliary measurement functions*

110% voltage application function	<p>Equipped with a voltage output terminal (T3) that applies a voltage that is 110% of rated voltage between the insulated SIP/SOP section, F-type applied part, or patient connections and ground.</p> <p>No-load output voltage: From -0% to +5% of power supply voltage of line input for equipment under test</p> <p>1 MΩ resistance load: Within $\pm 2\%$ of power supply voltage of line input for equipment under test</p> <p>Output impedance: $22.5 \pm 3 \text{ k}\Omega$ (including output protective resistance of $10 \text{ k}\Omega$ at 50/60 Hz)</p> <p>Output ON/OFF selection (a) Applied when positive phase (to input power supply voltage) (b) Applied when negative phase (to input power supply voltage) It is possible to automatically switch between (a) and (b) (automatic testing function)</p>
-----------------------------------	---

*only ST5540

10.3 Measurement System

Measurement system	Indication of a current value calculated based the measured drop in voltage caused by simulated resistance of the human body Measurement of true effective value The measurement section : chassis-grounded and floating		
Simulated resistance of human body (current detection circuit)	Network A	For Electrical Appliance and Material Safety Law	Basic measurement element : $1 \text{ k}\Omega$ Filter: $10 \text{ k}\Omega + 11.22 \text{ nF} + 579 \Omega$
	Network B1, B2*	For medical electrical equipment	Basic measurement element : $1 \text{ k}\Omega$ Filter: $10 \text{ k}\Omega + 15 \text{ nF}$
	Network C	For IEC 60990	Basic measurement element : $1.5 \text{ k}\Omega + 500 \Omega$ Filter1: $10 \text{ k}\Omega + 22 \text{ nF}$ Filter2: $10 \text{ k}\Omega + (20 \text{ k}\Omega + 6.2 \text{ nF}) // 9.1 \text{ nF}$
	Network D	For UL	Basic measurement element : $1.5 \text{ k}\Omega // 0.15 \mu\text{F}$
	Network E	General-purpose 1	Basic measurement element1 : $1 \text{ k}\Omega$
	Network F	General-purpose 2	Basic measurement element2 : $2 \text{ k}\Omega$
	Network G	For IEC 60601-1 For damp conditions	Basic measurement element : $375 \Omega // 0.22 \mu\text{F} + 500 \Omega$
Resistance tolerance of used elements: Resistance: $\pm 1\%$ Capacitor: $\pm 3\%$	Protective conductor current		Basic measurement element : 35Ω
Measurement procedure	Manual measurement	Measure each item while changing the measurement conditions	
	Automatic measurement	Automatic measurement of power supply polarity and equipment status Measurement time setting Set the delay (wait time) for state transitions	
Measurement terminals	Terminal T1, terminal T2 (with built-in fuse holder), Terminal T3 (110% voltage application terminal)*		

*only ST5540

Line output terminals	Terminal block (up to 20 A)			
A/D conversion system	$\Delta\Sigma$ system (20 bits)			
Input resistance	1 M Ω \pm 1% (single-ended input) excluding voltmeter section, simulated resistance of the human body (current detection circuit)			
Input capacity (between terminals T1 and T2)	150 pF or lower (f = 100 kHz, with network circuit isolated, Cable included)			
Grounding capacity (between terminals T1/T2 and chassis)	200 pF or lower			
Measurement frequency (switchable)*	(a) 15 Hz to 1 MHz (b) 0.1 Hz to 1 MHz			
CMRR (between terminals T1/T2 and chassis)	60 dB or more at 60 Hz	60 dB or more at 10 kHz	40 dB or more at 100 kHz	40 dB or more at 1 MHz

*only ST5540

10.4 Accuracy

Current Measurement Section

Operating temperature and humidity for guaranteed accuracy : $23 \pm 5^\circ\text{C}$ ($73 \pm 41^\circ\text{F}$), 80% RH or lower (no dew condensation allowed)

Temperature coefficient: $0.1 \times \text{basic accuracy} \times (T-23)$ weighted --- operating temperature T [$^\circ\text{C}$]

Warm-up time : 20 min.

- Input crest value is allowed up to 1.5 times the range
- When networks D and F are used, the guaranteed accuracy ranges (full-scale value of each range) are 0.67 and 0.5 times, respectively
- Value calculated based on voltage detected at terminals of a network having a non-inductive resistance of 1 k Ω .
- Measurements in voltage measurement mode conform to the accuracy listed below. (1 mA=1 V)

Measurement of DC

Range	Guaranteed accuracy range	Measurement resolution	Accuracy
50.00 mA	4.000 mA to 50.00 mA	10 μA	$\pm 2.0\% \text{rdg.} \pm 6 \text{dgt.}$
5.000 mA	0.400 mA to 5.000 mA	1 μA	$\pm 2.0\% \text{rdg.} \pm 6 \text{dgt.}$
500.0 μA	40.0 μA to 500.0 μA	0.1 μA	$\pm 2.0\% \text{rdg.} \pm 6 \text{dgt.}$
50.00 μA	4.00 μA to 50.00 μA	0.01 μA	$\pm 2.0\% \text{f.s.}$

Measurement of AC/AC + DC

(During AC measurements, the frequency characteristics of the high-pass filter ($f_c=4$ Hz) is added)

Range	Guaranteed accuracy range	Measurement resolution	Accuracy		
			$0.1 \text{ Hz} \leq f < 15 \text{ Hz}$	$15 \text{ Hz} \leq f \leq 100 \text{ kHz}$	$100 \text{ kHz} < f \leq 1 \text{ MHz}$
50.00 mA	4.000 mA to 50.00 mA	10 μA	$\pm 4.0\% \text{rdg.} \pm 10 \text{dgt.}$	$\pm 2.0\% \text{rdg.} \pm 6 \text{dgt.}$	$\pm 2.0\% \text{rdg.} \pm 10 \text{dgt.}$
5.000 mA	0.400 mA to 5.000 mA	1 μA	$\pm 4.0\% \text{rdg.} \pm 10 \text{dgt.}$	$\pm 2.0\% \text{rdg.} \pm 6 \text{dgt.}$	$\pm 2.0\% \text{rdg.} \pm 10 \text{dgt.}$
500.0 μA	40.0 μA to 500.0 μA	0.1 μA	$\pm 4.0\% \text{rdg.} \pm 10 \text{dgt.}$	$\pm 2.0\% \text{rdg.} \pm 6 \text{dgt.}$	$\pm 2.0\% \text{rdg.} \pm 10 \text{dgt.}$
50.00 μA	4.00 μA to 50.00 μA	0.01 μA	$\pm 4.0\% \text{f.s.}$	$\pm 2.0\% \text{f.s.}$	$\pm 2.0\% \text{f.s.}$

Measurement of AC Peak

(Disabled in network A and B and when the filter is set to Off in network C)

Range	Guaranteed accuracy range	Measurement resolution	Accuracy		
			$15 \text{ Hz} \leq f \leq 10 \text{ kHz}$	$10 \text{ kHz} < f \leq 100 \text{ kHz}$	$100 \text{ kHz} < f \leq 1 \text{ MHz}$
75.0 mA	8.0 mA to 75.0 mA	100 μA	$\pm (2\% \text{rdg.} \pm 6 \text{dgt.})$	$\pm 5.0\% \text{f.s.}$	$\pm 15.0\% \text{f.s.}$
10.00 mA	0.80 mA to 10.00 mA	10 μA	$\pm (2\% \text{rdg.} \pm 6 \text{dgt.})$	$\pm 5.0\% \text{f.s.}$	$\pm 15.0\% \text{f.s.}$
1.000 mA	0.100 mA to 1.000 mA	1 μA	$\pm 2.5\% \text{f.s.}$	$\pm 5.0\% \text{f.s.}$	$\pm 15.0\% \text{f.s.}$
500.0 μA	40.0 μA to 500.0 μA	0.1 μA	$\pm 4.0\% \text{f.s.}$	$\pm 5.0\% \text{f.s.}$	$\pm 20.0\% \text{f.s.}$

Voltage monitor accuracy (Less than 80 V is indicated as "Less than 80 V")

Range	Guaranteed accuracy range	Measurement resolution	Accuracy
300 V	85 V to 275 V	0.1 V	$\pm 5\% \text{rdg.} \pm 10 \text{dgt.}$

Current monitor accuracy (Less than 0.5 A is indicated as "Less than 0.5 A")

Measurement method: average value response, effective value conversion

Range	Guaranteed accuracy range	Measurement resolution	Accuracy
20 A	0.5 A to 20 A	0.1 A	$\pm 2\% \text{rdg.} \pm 5 \text{dgt.}$

Protective conductor current accuracy
Measurement of DC

Range	Guaranteed accuracy range	Measurement resolution	Accuracy
50.00 mA	12.00 mA to 50.00 mA	10 μ A	$\pm 2.0\%$ rdg. ± 6 dgt.
10.00 mA	1.30 mA to 13.00 mA	10 μ A	$\pm 2.0\%$ rdg. ± 6 dgt.

Measurement of AC/AC + DC

(During AC measurements, the frequency characteristics of the high-pass filter ($f_c=4$ Hz) is added)

Range	Guaranteed accuracy range	Measurement resolution	Accuracy	
			15 Hz \leq f \leq 100 kHz	100 kHz < f \leq 1 MHz
50.00 mA	12.00 mA to 50.00 mA	10 μ A	$\pm 2.0\%$ rdg. ± 6 dgt.	$\pm 5.0\%$ rdg. ± 20 dgt.
10.00 mA	1.30 mA to 13.00 mA	10 μ A	$\pm 2.0\%$ rdg. ± 6 dgt.	$\pm 5.0\%$ rdg. ± 20 dgt.

ACPeak

Range	Guaranteed accuracy range	Measurement resolution	Accuracy		
			15Hz \leq f \leq 10 kHz	10 kHz < f \leq 100 kHz	100 kHz < f \leq 1 MHz
75.0 mA	12.0 mA to 75.0 mA	100 μ A	$\pm 2\%$ rdg. ± 6 dgt.	$\pm 5.0\%$ f.s.	$\pm 25.0\%$ f.s.
10.00 mA	1.30 mA to 13.00 mA	10 μ A	$\pm 2.5\%$ f.s.	$\pm 5.0\%$ f.s.	$\pm 25.0\%$ f.s.

Network Section

Network accuracy

Network name/filter status	Characteristic*1, *2		
	DC input resistance	Frequency range with $\pm 1\%$ deviation	Cut-off frequency (-3 dB points*4)
A/Filter OFF*3	1 k Ω $\pm 1\%$	100 kHz or lower	–
A/Filter ON	1 k Ω $\pm 1\%$	–	1326 ± 20 Hz
B1*, B2* / Filter OFF*3	1 k Ω $\pm 1\%$	100 kHz or lower	–
B1*, B2* / Filter ON	1 k Ω $\pm 1\%$	–	1047 ± 16 Hz
C/Filter OFF	2 k Ω $\pm 1\%$	–	1811 ± 27 Hz
C/Filter ON1	2 k Ω $\pm 1\%$	–	3470 ± 104 Hz*4
C/Filter ON2	2 k Ω $\pm 1\%$	–	9100 ± 273 Hz*4
D	1.5 k Ω $\pm 1\%$	–	705 ± 15 Hz
E*3	1 k Ω $\pm 1\%$	100 kHz or lower	–
F	2 k Ω $\pm 1\%$	100 kHz or lower	–
G	875 Ω $\pm 1\%$	–	1997 Hz ± 27 Hz

*only ST5540

Network name/filter status	Accuracy (Deviation from theoretical value. Includes accuracy of internal voltmeter)				
	Measured current range	AC, AC+DC		ACpeak	
		50 mA, 5 mA, 500 μ A	50 μ A	75 mA, 10 mA	1 mA, 500 μ A
A/Filter OFF*3	0.1Hz < f < 10 kHz 10 kHz \leq f < 100 kHz 100 kHz \leq f \leq 1MHz	$\pm 4\%$ rdg. ± 10 dgt.	$\pm 4\%$ f.s.	–	–
A/Filter ON	0.1Hz < f < 10 kHz 10 kHz \leq f < 100 kHz 100 kHz \leq f \leq 1MHz	$\pm 4\%$ rdg. ± 10 dgt. ± 1.5 dBrdg. ± 10 dgt. ± 1.5 dBrdg. ± 10 dgt.	$\pm 4\%$ f.s. ± 1.5 dBrdg. $\pm 2\%$ f.s. ± 1.5 dBrdg. $\pm 2\%$ f.s.	–	–
B1*, B2* / Filter OFF*3	0.1Hz < f < 10 kHz 10 kHz \leq f < 100 kHz 100 kHz < f < 1MHz	$\pm 4\%$ rdg. ± 10 dgt.	$\pm 4\%$ f.s.	–	–

10.4 Accuracy

Network name/filter status	Accuracy (Deviation from theoretical value. Includes accuracy of internal voltmeter)				
	Measured current	AC, AC+DC		ACpeak	
	range	50 mA, 5 mA, 500 μ A	50 μ A	75 mA, 10 mA	1 mA, 500 μ A
B1*, B2* / Filter ON	0.1Hz < f < 10 kHz 10 kHz \leq f < 100 kHz 100 kHz \leq f \leq 1MHz	$\pm 4\%$ rdg. ± 10 dgt. ± 1.5 dBrdg. ± 10 dgt. ± 1.5 dBrdg. ± 10 dgt.	$\pm 4\%$ f.s. ± 1.5 dBrdg. $\pm 2\%$ f.s. ± 1.5 dBrdg. $\pm 2\%$ f.s.	–	–
C/Filter OFF	0.1Hz < f < 10 kHz 10 kHz \leq f < 100 kHz 100 kHz \leq f \leq 1MHz	$\pm 4\%$ rdg. ± 10 dgt. ± 1.5 dBrdg. ± 10 dgt. ± 1.5 dBrdg. ± 10 dgt.	$\pm 4\%$ f.s. ± 1.5 dBrdg. $\pm 2\%$ f.s. ± 1.5 dBrdg. $\pm 2\%$ f.s.	–	–
C/Filter ON1	0.1Hz < f < 10 kHz 10 kHz \leq f < 100 kHz 100 kHz \leq f \leq 1MHz	$\pm 4\%$ rdg. ± 10 dgt. ± 1.5 dBrdg. ± 10 dgt. ± 3.5 dBrdg. ± 10 dgt.	$\pm 4\%$ f.s. ± 1.5 dBrdg. $\pm 2\%$ f.s. ± 3.5 dBrdg. $\pm 2\%$ f.s.	$\pm 4\%$ rdg. ± 10 dgt. ± 1.5 dBrdg. $\pm 5\%$ f.s. ± 3.5 dBrdg. $\pm 15\%$ f.s.	$\pm 4\%$ f.s. ± 1.5 dBrdg. $\pm 5\%$ f.s. ± 3.5 dBrdg. $\pm 15\%$ f.s.
C/Filter ON2	0.1Hz < f < 10 kHz 10 kHz \leq f < 100 kHz 100 kHz \leq f \leq 1MHz	$\pm 4\%$ rdg. ± 10 dgt. ± 1.5 dBrdg. ± 10 dgt. ± 3.5 dBrdg. ± 10 dgt.	$\pm 4\%$ f.s. ± 1.5 dBrdg. $\pm 2\%$ f.s. ± 3.5 dBrdg. $\pm 2\%$ f.s.	$\pm 4\%$ rdg. ± 10 dgt. ± 1.5 dBrdg. $\pm 5\%$ f.s. ± 3.5 dBrdg. $\pm 15\%$ f.s.	$\pm 4\%$ f.s. ± 1.5 dBrdg. $\pm 5\%$ f.s. ± 3.5 dBrdg. $\pm 15\%$ f.s.
D*6	0.1Hz < f < 10 kHz 10 kHz \leq f \leq 1MHz	Theoretical impedance value $\pm 2\%$ Including voltmeter $\pm 4\%$ rdg. ± 6 dgt. Theoretical impedance value $\pm 3\% \pm 6\Omega$ Including voltmeter $\pm 5\%$ rdg. ± 6 dgt.	Theoretical impedance value $\pm 2\%$ Including voltmeter $\pm 4\%$ rdg. ± 6 dgt. Theoretical impedance value $\pm 3\% \pm 6\Omega$ Including voltmeter $\pm 5\%$ rdg. ± 6 dgt.	–	–
E*3	0.1Hz < f < 10 kHz 10 kHz \leq f \leq 100 kHz 100 kHz \leq f \leq 1MHz	$\pm 4\%$ rdg. ± 10 dgt.	$\pm 4\%$ f.s.	$\pm 4\%$ rdg. ± 10 dgt. $\pm 5\%$ f.s. $\pm 15\%$ f.s.	$\pm 4\%$ f.s. $\pm 5\%$ f.s. $\pm 15\%$ f.s.
F	0.1Hz < f < 10 kHz 10 kHz \leq f < 100 kHz 100 kHz \leq f \leq 1MHz	$\pm 4\%$ rdg. ± 10 dgt.	$\pm 4\%$ f.s.	$\pm 4\%$ rdg. ± 10 dgt. $\pm 5\%$ f.s. $\pm 15\%$ f.s.	$\pm 4\%$ f.s. $\pm 5\%$ f.s. $\pm 15\%$ f.s.
G	0.1Hz < f < 10 kHz 10 kHz \leq f < 100 kHz 100 kHz \leq f \leq 1MHz	$\pm 4\%$ rdg. ± 10 dgt. ± 1.5 dBrdg. ± 10 dgt. ± 1.5 dBrdg. ± 10 dgt.	$\pm 4\%$ f.s. ± 1.5 dBrdg. $\pm 2\%$ f.s. ± 1.5 dBrdg. $\pm 2\%$ f.s.	$\pm 4\%$ rdg. ± 10 dgt. ± 1.5 dBrdg. $\pm 5\%$ f.s. ± 1.5 dBrdg. $\pm 15\%$ f.s.	$\pm 4\%$ f.s. ± 1.5 dBrdg. $\pm 5\%$ f.s. ± 1.5 dBrdg. $\pm 15\%$ f.s.

*1: Measurement (including cable capacity) between T1 and T2 in leakage current between enclosure and enclosure mode

*2: Including voltmeter (1 M Ω load) at network output section Input protective fuse is short-circuited.

*3: Network A (filter OFF), Network B1, B2 (filter OFF), Same circuit for network E

*4: -15 dB points for network C (filter ON1, ON2)

*5: 0.1 Hz only at Network B2. Other Network from 15 Hz.

*6: Impedance theoretical values do not include the network output unit voltmeter (1 M Ω load)

NOTE

The value $\pm x$ dBrdg is applied to the stipulated value (dB) under various standards.

10.5 Other Functions

Trigger system	(a) Manual: automatic generation of internal trigger, and free-run measurement (b) Automatic: measurement started by external start signal
Refresh rate	(a) When set to 15 Hz DC, AC, AC+DC 500 ms ACpeak 600 ms (b) When set to 0.1 Hz DC, AC, AC+DC 5 s
Wiring check function	(a) Polarity check (voltage monitor) (b) VA check (voltage monitor x current monitor)
Voltage application line selection function	Selected from the following (a) or (b) for leakage current measurement between enclosure and line and touch current (enclosure-line) measurement : (a) Use of T2 and internal contact (default) (b) Use of T1 and T2
Ground fault prevention function	Pre-check of current value between connection terminals to prevent a ground fault During touch current (enclosure-line) measurement, enclosure - line leakage current measurement and polarity switching
Setting of single-fault condition	(a) Setting of fault mode for power line for equipment under test (1) Disconnection of one wire in power line (neutral side) (2) Disconnection of protective earth conductor During use of the automatic measurement function, polarity switching and (1) and (2) can be automatically switched. (b) Application of 110% voltage for simulated connection of malfunctioning equipment. (1)Positive phase (2)Negative phase During use of the automatic measurement function, (1) and (2) can be automatically switched (c) Selection of application line for leakage current measurement between enclosure and line and touch current (enclosure-line) measurement (1) Application of voltage of L (live) side of line input (2) Application of voltage of N (neutral) side of line input During use of the automatic measurement function (1) and (2) can be automatically switched
Power line for equipment under test (switching power supply polarity)	(a) Positive phase (b) Negative phase During use of the automatic measurement function (a) and (b) can be automatically switched
Power on polarity switching function*	Available when instrument is combined with an isolation transformer
Setting of measuring time	Setting of measuring time for each item Setting range : 1 sec. to 5 min., in 1 sec. increments Effective only in automatic measurement (when 0.1 Hz - 1 MHz is set ; equipped with pre-check function)*
Measurement delay (setting) function	(a) Setting of wait time from the completion of measurement to power supply disconnection (Default : 0sec) (b1)Set the wait time until power is turned on after polarity switching. (Default : 0 sec.) (b2) After (b1), set wait time until start of measurement (Default : 0 sec) (c) Setting of wait time for operations other than switching polarity (Default : 1 sec.) Setting range : 1 sec. to 30 min., in 1 sec. increments (When selecting network B1, 0 sec. to 30 min.) (when 0.1 Hz - 1 MHz is set ; equipped with pre-check function)*

*only ST5540

10.5 Other Functions

Maximum value hold function	Effective in all measurement modes Reset by Clear key during sampling Reset by changing allowable value Reset by START signal (EXT I/O, communication command)								
Allowable value judgement function	Allowable value : Sets the upper-limit current value/lower-limit current value. Judgment : <table border="0"> <tr> <td>PASS</td> <td>Lower limit value \leq measurement value \leq Upper limit value</td> </tr> <tr> <td>FAIL</td> <td>Measurement value > upper-limit current value</td> </tr> <tr> <td>LOW</td> <td>Measurement value < lower-limit current value</td> </tr> <tr> <td>"---"</td> <td>Measurement error (No measurement value can be obtained or instrument is outside guaranteed accuracy range)</td> </tr> </table>	PASS	Lower limit value \leq measurement value \leq Upper limit value	FAIL	Measurement value > upper-limit current value	LOW	Measurement value < lower-limit current value	"---"	Measurement error (No measurement value can be obtained or instrument is outside guaranteed accuracy range)
PASS	Lower limit value \leq measurement value \leq Upper limit value								
FAIL	Measurement value > upper-limit current value								
LOW	Measurement value < lower-limit current value								
"---"	Measurement error (No measurement value can be obtained or instrument is outside guaranteed accuracy range)								
Mode selection function	Processing : Indication, beep, judgment output from EXT I/O Beep : Selectable from "ON when PASS," "ON when FAIL," and "OFF" <table border="0"> <tr> <td>(a) Current measurement function</td> <td>(1) Unit of current measurement : Auto (2) Unit of current measurement : mA, fixed Normal leakage current measurement function, selectable unit of current measurement (default)</td> </tr> <tr> <td>(b) Voltage measurement function</td> <td>Isolates the internal network for using the instrument as a voltmeter between terminals T1 and T2 Selectable target voltage and measurement range Maximum measurement voltage : 50 V</td> </tr> <tr> <td>(c) Protective conductor current measurement</td> <td>Selectable modes (AC, DC, AC + DC, ACPeak)</td> </tr> </table>	(a) Current measurement function	(1) Unit of current measurement : Auto (2) Unit of current measurement : mA, fixed Normal leakage current measurement function, selectable unit of current measurement (default)	(b) Voltage measurement function	Isolates the internal network for using the instrument as a voltmeter between terminals T1 and T2 Selectable target voltage and measurement range Maximum measurement voltage : 50 V	(c) Protective conductor current measurement	Selectable modes (AC, DC, AC + DC, ACPeak)		
(a) Current measurement function	(1) Unit of current measurement : Auto (2) Unit of current measurement : mA, fixed Normal leakage current measurement function, selectable unit of current measurement (default)								
(b) Voltage measurement function	Isolates the internal network for using the instrument as a voltmeter between terminals T1 and T2 Selectable target voltage and measurement range Maximum measurement voltage : 50 V								
(c) Protective conductor current measurement	Selectable modes (AC, DC, AC + DC, ACPeak)								
Setting the grounding class and applied part of equipment under test	Selected from Class-I equipment, Class-II equipment, or internally powered equipment (When selecting network B1 or B2, select the applied part from the Type B applied part, Type BF applied part, or Type CF applied part)*								

*only ST5540

10.6 System-related Functions

Beep sound setting	<p>(a) Allowable value judgment : Selectable from "ON when Pass," "ON when FAIL," and "OFF"</p> <p>(b) Key input : Selectable from ON/OFF</p> <p>(c) T3 (110% voltage application terminal) output : Selectable from ON/OFF*</p> <p>(d) Line voltage output from T2 : Selectable from ON/OFF</p>
Save/load function	30 panels for saving the following setting data (measurement mode, network, equipment name, control number, grounding class, applied part, measurement range, filter, target current, allowable value setting, fault condition setting, power supply polarity switching, automatic measurement items, automatic measuring time, measurement delay time, Panel name)
Data save function	<p>Saved content : Equipment under test information (equipment name, serial number), measurement data, date</p> <p>Memory capacity : Data on up to 100 units</p>
Clock function	<p>Auto calendar, automatic leap-year adjustment, 24 hour clock</p> <p>Clock accuracy: Deviation of about 4 minutes a month</p>
Data backup function	<p>SRAM (Set condition), RTC</p> <p>Backup battery life: Approx. 10 years (reference value at 25 °C (77 °F))</p>
Backlight automatic OFF function	<p>(a) Constant ON (default)</p> <p>(b) Auto OFF (1 min. to 30 min., in 1 min. increments)</p> <p>The backlight automatically turns off after the set time elapses, turns ON when a key is pressed, then turns OFF again after the set time elapses.</p>
Self-test function	<p>(a) MEM (internal RAM)</p> <p>(b) KEY (6 x 6 matrix touch panel)</p> <p>(c) LCD (front LCD panel)</p> <p>(d) LED (warning lamp, LCD backlight)</p> <p>(e) Beep sound</p>
Language setting	<p>(a) Japanese</p> <p>(b) English (default)</p>
Fuse blown check function	<p>Checks for blown fuses in the network</p> <p>At power on (when set) or key operation in the system screen</p>
Relay check function	<p>Checks whether the network relay works normally</p> <p>At power on (when set) or key operation in the system screen</p>
Allowable lower limit value setting	Sets a lower limit value for all measurements.
System reset	<p>(a) Returns instrument to its factory defaults (includes measurement data, setting conditions, etc.)</p> <p>(b) Clears all measurement data.</p> <p>(c) Clears all condition setting data including panels.</p>

*only ST5540

10.7 User interface

Display	320 x 240 dot matrix LCD (with backlight) LCD contrast adjustment : Provided with front panel control
Operation panel	6 x 6 matrix touch panel Key lock function provided (asserts KEYLOCK terminal on EXT I/O)

10.8 EXT I/O

External I/O (standard)	<ul style="list-style-type: none"> • Connector : 36-pin, female • Isolation (output: internal + 3.3 V power supply, internal GND (equivalent to chassis grounding) • Negative logic, open collector output • Input: <table border="0" style="margin-left: 20px;"> <tr> <td>START</td> <td>Measurements start when this signal is set to LO</td> </tr> <tr> <td>STOP</td> <td>Terminated when set to LO</td> </tr> <tr> <td>KEYLOCK</td> <td>Disable all except Start switch</td> </tr> <tr> <td>LOAD0(to 4)</td> <td>Reads saved panel (30 panels)</td> </tr> <tr> <td>(EXT.DCV)</td> <td>External power 5 to 24 V DC input</td> </tr> <tr> <td>(EXT.COM)</td> <td>External COM input</td> </tr> </table> • Output: <table border="0" style="margin-left: 20px;"> <tr> <td>TEST</td> <td>Outputs LO during measurements (automatic measurement only)</td> </tr> <tr> <td>MEAS</td> <td>When there are multiple measurement items, an equivalent number of outputs are generated</td> </tr> <tr> <td>PASS</td> <td>Outputs PASS judgment result for each measurement item</td> </tr> <tr> <td>FAIL</td> <td>Outputs FAIL judgment result for each measurement item</td> </tr> <tr> <td>LOW</td> <td>Outputs LOW judgment result for each measurement item. Continues output if a single LOW state is produced during automatic tests produced during automatic tests</td> </tr> <tr> <td>T-FAIL</td> <td>Generates output even if one FAIL judgment result is produced during automatic tests</td> </tr> <tr> <td>(INT.DCV)</td> <td>Internal 5 V DC output (isolated from internal circuits)</td> </tr> <tr> <td>(INT.GND)</td> <td>Internal GND output (equivalent to chassis grounding)</td> </tr> </table> 	START	Measurements start when this signal is set to LO	STOP	Terminated when set to LO	KEYLOCK	Disable all except Start switch	LOAD0(to 4)	Reads saved panel (30 panels)	(EXT.DCV)	External power 5 to 24 V DC input	(EXT.COM)	External COM input	TEST	Outputs LO during measurements (automatic measurement only)	MEAS	When there are multiple measurement items, an equivalent number of outputs are generated	PASS	Outputs PASS judgment result for each measurement item	FAIL	Outputs FAIL judgment result for each measurement item	LOW	Outputs LOW judgment result for each measurement item. Continues output if a single LOW state is produced during automatic tests produced during automatic tests	T-FAIL	Generates output even if one FAIL judgment result is produced during automatic tests	(INT.DCV)	Internal 5 V DC output (isolated from internal circuits)	(INT.GND)	Internal GND output (equivalent to chassis grounding)
START	Measurements start when this signal is set to LO																												
STOP	Terminated when set to LO																												
KEYLOCK	Disable all except Start switch																												
LOAD0(to 4)	Reads saved panel (30 panels)																												
(EXT.DCV)	External power 5 to 24 V DC input																												
(EXT.COM)	External COM input																												
TEST	Outputs LO during measurements (automatic measurement only)																												
MEAS	When there are multiple measurement items, an equivalent number of outputs are generated																												
PASS	Outputs PASS judgment result for each measurement item																												
FAIL	Outputs FAIL judgment result for each measurement item																												
LOW	Outputs LOW judgment result for each measurement item. Continues output if a single LOW state is produced during automatic tests produced during automatic tests																												
T-FAIL	Generates output even if one FAIL judgment result is produced during automatic tests																												
(INT.DCV)	Internal 5 V DC output (isolated from internal circuits)																												
(INT.GND)	Internal GND output (equivalent to chassis grounding)																												

10.9 Relay output for medical equipment (only ST5540)

Relay output	S10 : Relay between functional earth terminal and measurement power supply system ground
	S12 : Relay between patient connection and measurement power supply circuit ground
	S13 : Relay between metal accessible part not protectively earthed and earth

10.10 PC Interfaces

RS-232C interfaces

Communication content : Remote control, Measurement value output
 Transmission system : Synchronous communication, full duplex
 Transmission speed : 9,600 bps, fixed
 Data bit length : 8 bits, Stop bit : 1, Parity bit : None
 Delimiter : CR+LF
 Handshake : None
 XON/XOFF : Not used
 Connector : D-sub 9-pin, male, connector retaining screws (#4-40)

USB interfaces

Communication content : Remote control, Measurement value output
 Conforms to USB V1.1 (RS-232C conversion, 9600 bps)
 Connector : Series A receptacle

10.11 Printer

NOTE

The 9442 Printer (option) is required for printing measurement data.

Printer output	RS-232C interface terminal used
	Printer, printer cable, AC adapter and printing paper are separately sold
Printed information	Date of measurement (2009/10/01) Equipment name (ELECTRIC-123) Control number (123456789012) Network (B) Class (I, II, Internal) Applied part (B, BF, CF) only network B1 and B2 Measurement mode (Earth leakage current, Enclosure leakage current, and so on) Filter setting (ON, OFF) Target current (AC, DC, AC+DC, ACPeak) Allowable value (1.000 mA) Maximum value (0.567 mA) Judgment result (PASS/FAIL/LOW) Power supply polarity (Positive phase, Negative phase) Equipment status (Normal, Disconnected grounding wire, and so on) S10, 12, 13 test results* Information to be printed can be selected from the items above. All data is printed in English

*only ST5540

10.12 General Specifications

Operating temperature and humidity	0 to 40°C (32 to 104°F), 80% RH or less (non-condensating)
Storage temperature and humidity	-10 to 50°C (14 to 122°F), 80% RH or less (non-condensating)
Operating temperature and humidity for guaranteed accuracy	Approx. 23°C (Approx. 73°F), 80% RH or less (non-condensating)
Period of guaranteed accuracy	1 year
Operating Environment	Indoors, altitude up to 2000 m (6562-ft.)
Power source for main instrument	Rated power source voltage : 100, 120, 220, 240 VAC (default setting) (Voltage fluctuations of $\pm 10\%$ from the rated supply voltage are taken into account.) Rated power source frequency : 50/60 Hz Rated power : 30 VA
Line power supply and outlet for equipment under test	Rated power supply voltage : 100 to 250 VAC (Voltage fluctuations of $\pm 10\%$ from the rated supply voltage are taken into account.) Rated power supply frequency : 50/60 Hz Rated current Input : 20 A (terminal block), Output : 20 A (terminal block) Rated power : 250 V
Time of continuous operation	At maximum load: 30 min
Power output	50 mA
Maximum allowable leakage current	
Withstand voltage	<ul style="list-style-type: none"> • [All power supply terminals] - [Protective earthing] 1.62 kVAC, 60 sec. Cut-off current 5 mA • [All measurement terminals] - [All power supply terminals] 3.00 kVAC, 60 sec. Cut-off current 10 mA • [All measurement terminals] - [Control circuit] 3.00 kVAC, 60 sec. Cut-off current 10 mA
Measurement terminals	Terminals T1, T2 : Rated voltage 50 V, rated current 50 mA, earth voltage 250 V Terminal T3 : Maximum output voltage 250 VAC
Fuses	(a) Power supply section 250 V T200mAL
Only (b) can be replaced	(b) Measurement terminal section (T2 terminal) 250 V F50mAL (c) Measurement terminal section (relay PCB) 250V F50mAL
Size	Approx. 320W x 110H x 253D mm (12.60"W x 4.33"H x 9.96"D) (excluding protruding sections)
Weight	Approx. 4.5 kg (158.7 oz.)

*only ST5540

Applicable Standards	EMC EN 61326 Electric equipment for measurement, control and laboratory use - EMC requirements Part 1: General requirements EN 61000-3-2 High-frequency current EN 61000-3-3 Voltage fluctuations Safety EN61010 Contamination grade 2 T1, T2 terminals: Measurement category II (expected transient over voltage 2.5 kV) T3 terminal (expected transient over voltage 1.5 kV)*	
Effect of conducted disturbances, induced by radio frequency fields	Less than 3% at 3 V (typical value for 500 μ A)	
Accessories	L2200 Test Lead Test Lead (red)* 9195 Enclosure Probe Power cord AC IN : For powering instrument LINE IN* : one 15 A power cord with plug, one 20 A power cord without plug2 (Select a cord that suits the power supply of equipment under test) Varies with the target market for which the instrument was manufactured. (one 10 A power cord with plug, one 20 A power cord without plug) (Current value printed on connector) Spare fuses for measurement line 250 V F50mAL Instruction manual CD-ROM	1 set (1 red, 1 black) 1 1 3 1 2 1 1 1
Options	9637 RS-232C CABLE 9638 RS-232C CABLE 9442 PRINTER 9443-01 AC ADAPTER 9443-02 AC ADAPTER 9444 CONNECTION CABLE 1196 RECORDING PAPER	(9-pin to 9-pin., crossing cable) (9-pin to 25-pin., crossing cable) (for printer / Japan) (for printer / EU) (for printer, 9-pin to 9-pin, straight cable) (for printer, 112 mm x 25 m, 10 rolls)

*only ST5540

10.13 Compliant standards

Network A	Electrical Appliance and Material Safety Law	Ministerial ordinance establishing technical standards for electrical appliances
Network B1	Medical electrical equipment Part 1 General requirements for safety	IEC 60601-1:1988 +A1:1993 +A2:1995
	Medical electrical equipment-Part1: General requirements for basic safety and essential performance	JIS T 0601-1:1999
Network B2	Medical electrical equipment Part 1 General requirements for safety	IEC 60601-1:2005 3rd Edition
	Medical electrical equipment-Part1: General requirements for basic safety and essential performance	JIS T 0601-1:2012
Network C	Methods of measurement of touch current and protective conductor current	IEC 60990:1999
	Safety requirements for electrical equipment used in measurements, control and laboratories	IEC 61010-1:2010
	Information technology equipment - Safety	IEC 60950-1:2005
	Safety of household and similar electrical appliances Part 1: General requirements	IEC 60335-1:2010
	Audio, video and similar electronic equipment apparatus - Safety requirements	IEC 60065:2001 +A1:2005
	Personnel Protection Systems for EV	UL2231-1 (2002), UL-2231-2 (2002)
Network D	For UL	UL1492 (1996)
Network G	Safety requirements for electrical equipment used in measurements, control and laboratories Current measurement circuits for testing in damp conditions	IEC 61010-1:2010

10.14 Measurement Networks

Network A (for Electrical Appliance and Material Safety Law)

Network A is a measurement network that complies with the Electrical Appliance and Material Safety Law.

Network A complies with the following law :

- (1) Ordinance Concerning Technical Requirements for Electrical Appliances and Materials

Filter setting for single-frequency network (OFF) and multi-frequency network (ON)

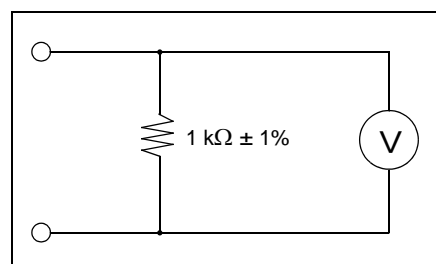

Single-frequency network (OFF)

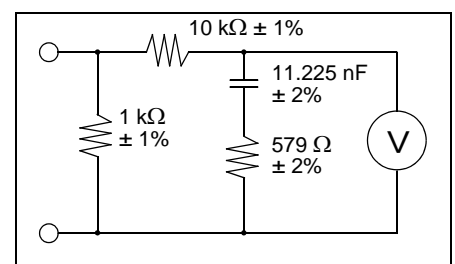

Multi-frequency network (ON)

When network A is selected, the instrument can also be used in compliance with the following standards on testing leakage current :

- (2) Automatic vending machines - Test method - (JIS B8561-93)

- (3) Microwaves (JIS C9250-92)

In addition to the Electrical Appliance and Material Safety Law, many JIS standards specify the use of a single-frequency network (with 1 kΩ non-inductive resistance only) for testing leakage current.

Applicable law	Ordinance Concerning Technical Requirements for Electrical Appliances and Materials
Measurement circuit configuration	Basic measurement element: 1 kΩ Frequency characteristic: $\pm 0.5\%$ (DC to 1 MHz)
Low-pass filter function	Filter configuration (ON setting): RC filter (10 kΩ + 11.22 nF + 579 Ω) Filter setting: ON/OFF (1 kΩ only at OFF) (with short-circuited input protective fuse)
Element tolerance	Resistance : $\pm 1\%$ (1 kΩ, 10 kΩ), $\pm 1\%$ $\pm 2\%$ (579 Ω) Capacitor : $\pm 2\%$

Network B1 (for JIS T 0601-1:1999)

Network B1 is a measurement network for medical electrical equipment.
Network B1 complies with the following standards :

- (1) Medical electrical equipment - Part 1 :
General requirements for safety
(JIS T 0601-1:1999)

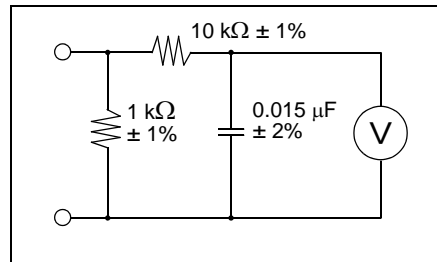

Network with a frequency characteristic (ON)

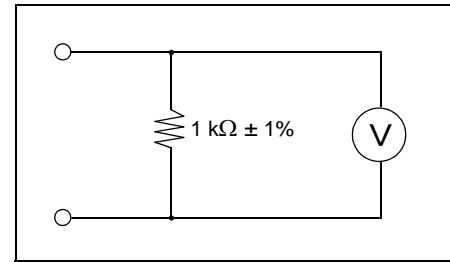

Network with 1 kΩ non-inductive resistance only (OFF)

When network B1 is selected, the instrument can also be used in compliance with the following standards on testing leakage current :

- (2) JIS standards for medical X-ray equipment

The instrument can be used for testing leakage current in isolation transformers in compliance with the safety standard for electrical facilities for hospitals (JIS T1022 : 96).

In addition to medical electrical equipment standards, many JIS standards specify the use of a network with 1 kΩ non-inductive resistance for testing leakage current.

Applicable standards	Medical electrical equipment - Part 1 : General requirements for safety IEC 60601-1:1988-12 +A1:1991-11 +A2:1995-03 General safety regulations for medical electrical equipment (JIS T 1001-92) General regulations for method of testing safety of medical electrical equipment (JIS T 1002-92)
Measurement circuit configuration	Basic measurement element: 1 kΩ Frequency characteristic: ±0.5% (DC to 1 MHz)
Low-pass filter function	Filter configuration (ON setting) : RC filter (10 kΩ + 15 nF) Filter setting : ON/OFF (1 kΩ only at OFF) (with short-circuited input protective fuse)
Element tolerance	Resistance : ± 1% Capacitor : ± 2%

Network B2 (for IEC 60601-1:2005 3rd)

This network complies with IEC 60601-1:2005 3rd edition.
The B2 measurement network complies with the following standard.

- (1) Medical electrical equipment - Part 1 : General requirements for safety (IEC 60601-1:2005 3rd)
- (2) General safety regulations for medical electrical equipment (JIS T 1001-92)
- (3) Medical electrical equipment-Part1:
General requirements for basic safety and essential performance (JIS T 0601-1:2012)

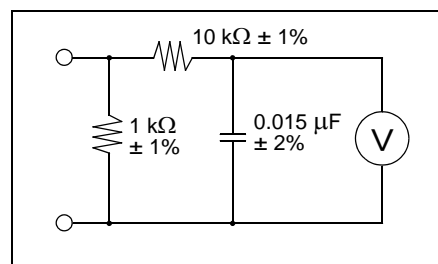

Network with a frequency characteristic (ON)

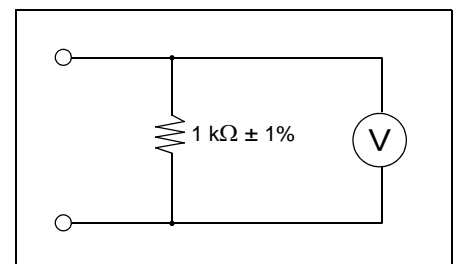

Network with 1 kΩ non-inductive resistance only (OFF)

When network B2 is selected, the instrument can also be used in compliance with the following standards on testing leakage current:

- (4) JIS standards for medical X-ray equipment
The instrument can be used for testing leakage current in isolation transformers in compliance with the safety standard for electrical facilities for hospitals (JIS T 1022-96).
In addition to medical electrical equipment standards, many JIS standards specify the use of a network with 1 kΩ non-inductive resistance for testing leakage current.

Applicable standards	(1) Medical electrical equipment - Part 1 : General requirements for safety IEC 60601-1:2005 3rd, JIS T 0601-1:2012 (2) Medical electrical safety regulations JIS T1001-92 (3) General regulations for method of testing safety of medical electrical equipment JIS T1002-92
Measurement circuit configuration	Basic measurement element: 1 kΩ Frequency characteristic: ±0.5% (DC to 1 MHz)
Filter configuration	Filter configuration (ON setting) : RC filter (10 kΩ + 15 nF) Filter setting : ON/OFF (1 kΩ only at OFF) (with short-circuited input protective fuse)
Element tolerance	Resistance : ± 1% Capacitor : ± 2%

Network C (for IEC 60990)

Network C is a measurement network that complies with IEC 60990.
Network C complies with the following standards :

- (1) Methods of measurement of touch current and protective conductor current (IEC 60990:1999)
Filter setting for human body impedance network (OFF), network compatible with perception/reaction (ON1 (U1,U2)), and network compatible with abandonment (ON2 (U1,U3))

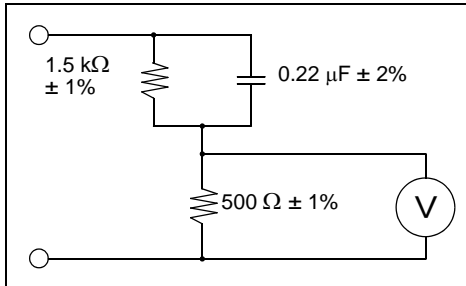

Human body impedance network(OFF)

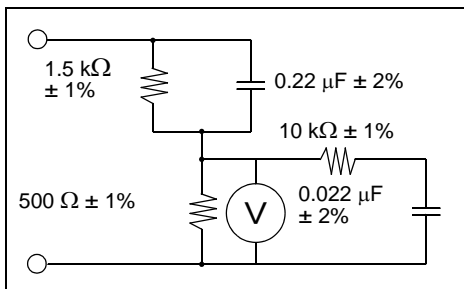
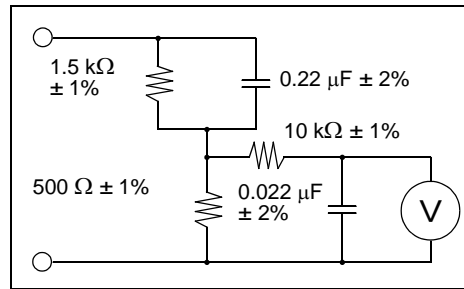
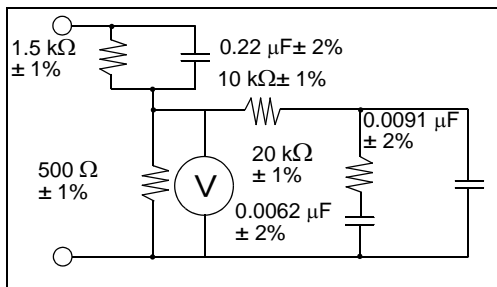
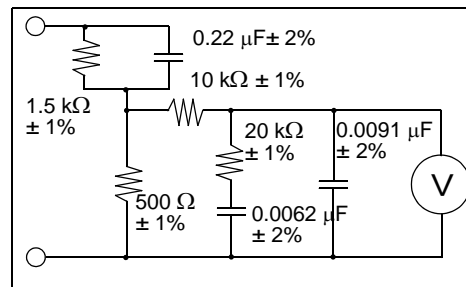
Network compatible with perception/
reaction(ON1(U1))Network compatible with
perception/reaction(ON1(U2))Network compatible with
abandonment(ON2(U1))Network compatible with
abandonment(ON2(U3))

When network C is selected, the instrument can also be used in compliance with the following standards on testing leakage current :

- (2) Safety requirements for electrical equipment for measurement, control, and laboratory use(IEC 61010-1:2010)
- (3) Safety of information technology equipment (IEC 60950-1:2005)

- (4) Audio, video, and similar electronic apparatus - Safety requirements (IEC 60065:2001 +A1:2005)
- (5) Safety of household and similar electrical appliances.
- Part 1: General requirements (IEC60335-1:2010)
- (6) Applicable UL standards (e.g.,UL 2231-1, UL-2231-2)There are many other applicable standards.

Applicable standards	Methods of measurement of touch current and protective conductor current IEC 60990:1999
Measurement circuit configuration	Basic measurement element : 1.5 k Ω + 500 Ω
Filter configuration	OFF setting : High-pass filter ON1 setting (compatible with perception) : 10 k Ω + 22 nF ON2 setting (compatible with abandonment) : 10 k Ω + (20 k Ω + 6.2 nF) // 9.1 nF (when input protective fuse is short-circuited)
Element tolerance	Resistance: \pm 1% Capacitor : \pm 2%

Network D (for UL)

Network D is a measurement network that complies with UL.

(1) Circuit Configuration

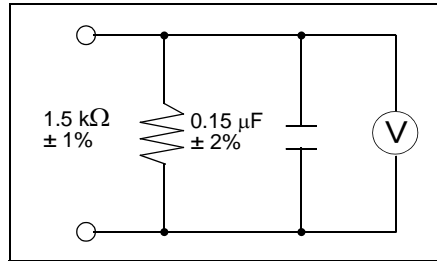

Network (1.5 kΩ) with 1.5 kΩ and 0.15 μF

When network D is selected, the instrument can also be used in compliance with the following standards on testing leakage current :

(2) There are many other applicable standards.

Applicable standards	Applicable UL standards (e.g., UL 471, UL 1310, UL 1437, UL 1492)
Measurement circuit configuration	Network with 1.5 kΩ and 0.15 μF (when input protective fuse is short-circuited)
Element tolerance	Resistance: ± 1% Capacitor : ± 2%

Network E (General-purpose 1)

Network E is a general-purpose measurement network.
The circuit configuration is as follows :

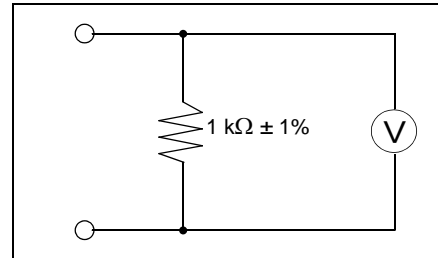

Network (1 kΩ) with 1 kΩ

This network can be used to perform leakage current tests in compliance with applicable standards.

Measurement circuit configuration	Network with 1 kΩ Impedance: 1 kΩ (0.5% (DC to 1 MHz) (when input protective fuse is short-circuited)
Element tolerance	Resistance : ± 1%

Network F (General-purpose 2)

Network F is a general-purpose measurement network.
The circuit configuration is as follows :

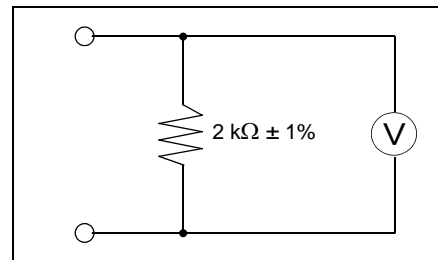

Network (2 kΩ) with 2 kΩ

This network can be used to conduct leakage current tests in compliance with applicable standards.

Measurement circuit configuration	Network with 2 kΩ Impedance : 2 kΩ (0.5% (DC to 1 MHz)) (when input protective fuse is short-circuited)
Element tolerance	Resistance : ± 1%

Network G (for IEC61010-1)

Network G is a measurement network that complies with IEC 61010-1. The G measurement network has the following circuit configuration.

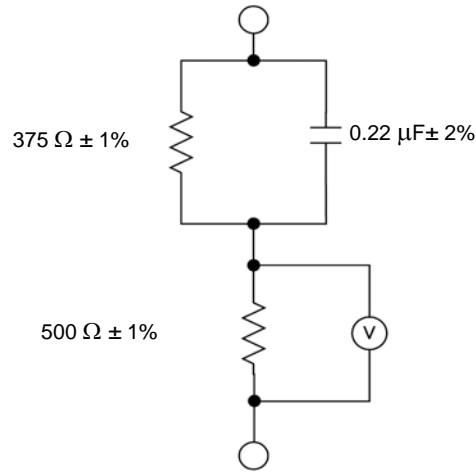

Network (875 kΩ) with 875 Ω

Applicable standards	IEC 61010-1:2010 Safety requirements for electrical equipment used in measurements, control and laboratories Current measurement circuits for testing in damp conditions
Measurement circuit configuration	Basic measurement element : 375 Ω + 500 Ω
Filter configuration	ON setting : 375 Ω, 500 Ω and 0.22 μF networks (when input protection fuse is short-circuited)
Element tolerance	Resistance: ± 1% Capacitor : ± 2%

Protective conductor current network

This is a network for measuring protective conductor current.
Protective conductor current has the following circuit configuration.

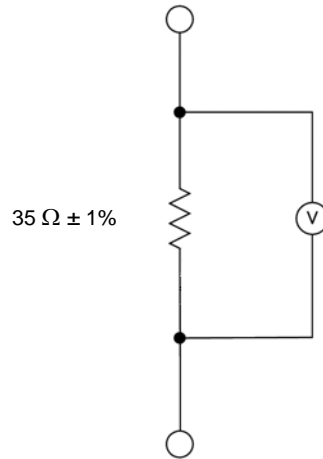

Network (35 Ω) with 35 Ω

This network can be used to conduct leakage current tests in compliance with applicable standards.

Measurement circuit configuration	Network with 35 Ω Impedance : 35 Ω (0.5% (DC to 1 MHz)) (when protection fuse is short-circuited)
Element tolerance	Resistance : ± 1%

Maintenance and Service

Chapter 11

11.1 Cleaning and Storage

To clean the instrument, wipe it gently with a soft cloth moistened with water or mild detergent. Never use solvents such as benzene, alcohol, acetone, ether, ketones, thinners or gasoline, as they can deform and discolor the case.

NOTE

Wipe the LCD gently with a soft, dry cloth.

Storage

- Storage temperature and humidity should be kept between -10 and 50°C (14 to 122°F), at less than 80% RH.
- Do not store or use the instrument where it could be exposed to direct sunlight, high temperature or humidity, or condensation. Under such conditions, the instrument may be damaged and insulation may deteriorate so that it no longer meets specifications.
- When storing the instrument for a long time (1 year or more), the specifications are no longer guaranteed. Therefore, before use, have the instrument recalibrated.

11.2 Repair and Servicing

WARNING

Do not attempt to modify, disassemble or repair the instrument; as fire, electric shock and injury could result.

CAUTION

- If damage is suspected, check the "Troubleshooting" section before contacting your dealer or Hioki representative.
- Pack the instrument so that it will not sustain damage during shipping, and include a description of existing damage. We do not take any responsibility for damage incurred during shipping.

- Use the original packing materials when transporting the instrument, if possible.
- If the instrument has been subject to moisture, or if oil and dust have accumulated in the instrument interior, the danger of electrical shock or fires resulting from the deterioration of insulation increases greatly.
- When storing the instrument for a long time(1 year or more),the specifications are no longer guaranteed. Therefore,before use,have the instrument recalibrated.

Replaceable Parts and Operating Lifetimes

Useful life depends on the operating environment and frequency of use. Operation cannot be guaranteed beyond the following periods. For replacement parts, contact your dealer or Hioki representative.

Part	Life
LCD(to half brightness)	Approx. 10,000 hours
Electrolytic Capacitors	Approx. 1,000 to 5,000 hours (105°C(221°F))
Lithium Battery	Approx. 10 years The instrument uses a lithium battery for memory backup. When this battery runs out, the data saved in memory is lost and measurement condition data can no longer be saved. If this happens, contact our service center for a battery replacement (at a charge).
Relay for power switch	Mechanical lifetime 2 million times Electrical lifetime 200,000 times
Relay for signal switch	Mechanical lifetime 100 million times electrical lifetime 1 million times

Troubleshooting

If abnormal operation occurs, check the following items.

If the instrument continues to operate abnormally after taking the specified corrective action, the instrument may be malfunctioning.

Turn off the instrument's power switch immediately, then contact your dealer or Hioki representative.

Symptom	Check item	Corrective action
The display remains blank after the power switch is turned on.	Is the power cord disconnected?	Check the power supply inlet indicated [AC IN] (located on the left side when viewed from the rear of the main instrument). Confirm that the power source voltage of the instrument matches the power supply voltage, then connect the power cord.
	Is the LCD panel contrast adjustment set to the lightest setting?	Adjust the contrast of the LCD panel by turning the black dial located on the right side of the LCD panel.
Keys are ineffective.	Is RS-232C or USB used for external remote control?	Stop using RS-232C or USB. When the instrument is remotely controlled, the keys are ineffective.
	Is the KEYLOCK terminal of EXT I/O set to Low level (EXT.COM level)?	Set the KEYLOCK terminal of EXT I/O to High level (EXT.VCC level), or leave the terminal open.
The power line for equipment under test does not provide power.	Is the power cord disconnected?	Check the power supply inlet indicated [LINE IN] (located on the right side when viewed from the rear of the main instrument), then connect the power cord.
	Is the circuit breaker located at the upper left on the instrument's front panel turned OFF?	Check the power consumption of equipment under test, then turn on the circuit breaker. (20 A max.) side : ON, ○ side : OFF
Leakage current measurement cannot be conducted.	Is the fuse for terminal T2 on the front panel blown?	Replace the fuse. (designated fuse : 250 V F50 mA L)
The clock loses or gains time.	The clock may lose or gain up to 4 minutes per month.	The built-in lithium battery provides backup power for the clock. When the battery becomes depleted, the instrument may display an incorrect date and time. If this happens, request battery replacement (at a charge). The service life of the backup battery is about 10 years.
The instrument displays "ERROR 1."	Does the power supply voltage match the specified power source voltage of the main instrument?	Confirm that the power supply voltage matches the specified power source voltage of the HiTESTER.
	Is the power fuse blown?	Contact your dealer or Hioki representative.
The instrument displays "ERROR 2."	This error indication should not appear in normal use.	The instrument is malfunctioning. Turn off the power switch of the main instrument immediately, then contact your dealer or Hioki representative.
Relay or fuse check results in NG.	<ul style="list-style-type: none"> Is power supplied to LINE IN? Is the breaker switched on? 	Confirm that the power cord is connected to the terminal block for [LINE IN] on the rear panel. Confirm that the breaker for the terminal block on the front panel is switched on. :ON ○ :OFF
The DANGER lamp stays on continuously.	Is an incorrect supply voltage being used?	Check the supply voltage. If this fails to resolve the issue, the instrument may be broken. Turn it off immediately and contact your dealer or Hioki representative.
Leakage current value is not stable. The measured value fluctuates.	The instrument may be exposed to external noise. When terminal T1 and T2 are used, try switching connections to T1 and T2, and making the measurement again. (Measuring after switching connections to terminal T1 and T2 is safe and not a problem.) The ST5541 and ST5541 converts the voltage used for internal sense resistance to current values.	

If the cause of the problem is unknown, reset the system.

This restores the instrument to the default conditions set at the factory.

See "7.2 Initializing the Instrument" (p. 134)

11.3 Replacing Fuses

Stop using the instrument in the cases described below.

Disconnect the power cord and test leads, then contact your dealer or Hioki representative.

- When instrument damage can be confirmed.
- When the instrument cannot be operated for measurement.
- When the instrument has been stored under high temperature and humidity for an extended time.
- When the instrument has been subjected to rough handling under adverse transport conditions.

11.3 Replacing Fuses



! WARNING

- Replace the fuse for measurement operation only with one of the specified characteristics and voltage and current ratings. Using a non-specified fuse or shorting the fuse holder may cause a life-threatening hazard.

Fuse for measurement operation 250V F50mAL

- To avoid electric shock, turn off the power switch and disconnect the power cord and test leads before replacing the fuse.
- Since a blown fuse in the power supply cannot be repaired or replaced by the customer, contact your dealer or Hioki representative. Use the VA check function to check for blown fuses in the power supply and the fuse check function to check for blown fuses in the measurement circuit.

Replacing the fuse for measurement operation (front panel)

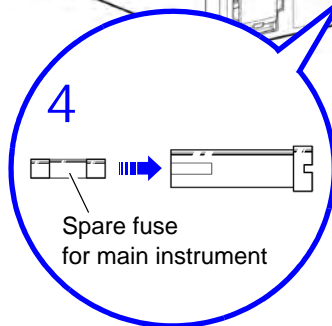
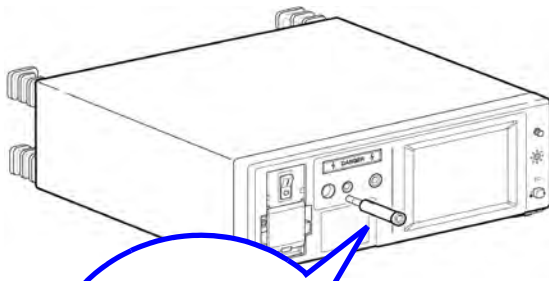

1. Turn the power switch OFF(O) then disconnect the power cord and test leads.
2. Turn off the circuit breaker.
3. Gently press the red holder at terminal T2, turn it 90 degrees, then remove the fuse holder.
4. Replace the fuse for measurement operation with one of the specified rating. Verify that the fuse has been inserted into the red holder.
5. With the indented section on the fuse holder facing up, insert the fuse holder into the socket on the main instrument, then turn it 90 degrees.

NOTE

- When removing the fuse holder, the fuse may remain in the instrument in rare instances. Tilt the instrument on its side and remove the fuse. Next, install a new fuse in the fuse holder and insert the holder, connecting it to terminal T2.
- Inserting the fuse holder and connecting it to terminal T2 while a fuse still remains in the instrument will cause the fuse to fall into the instrument.

11.4 Instrument Disposal

The instrument contains a lithium battery for system memory backup.

! WARNING

- To avoid electric shock, turn off the power switch and disconnect the power cord and test leads before removing the lithium battery.
- When disposing of this instrument, remove the lithium battery and dispose of battery and instrument in accordance with local regulations.
- Keep batteries away from children to prevent accidental swallowing.

! CAUTION

If the protective functions of the instrument are damaged, either remove it from service or mark it clearly so that others do not use it inadvertently.

Removing the lithium battery

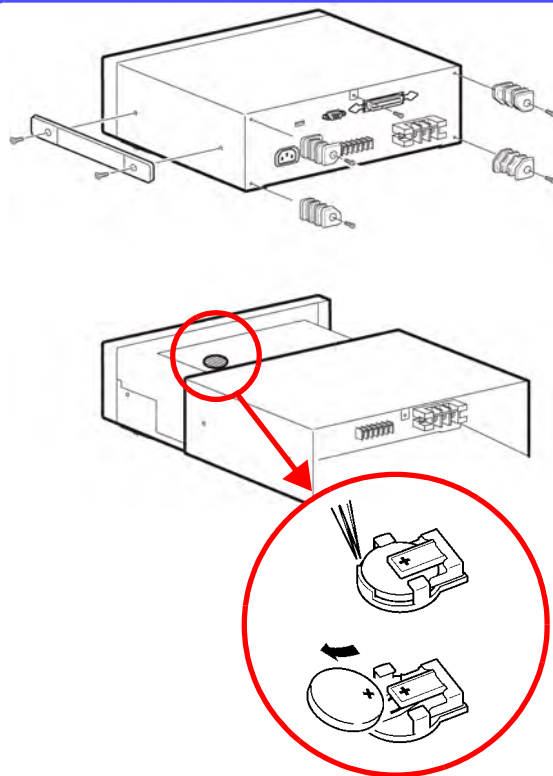

Required tools

- Phillips screwdriver 1 pc.
- Forceps 1 set



1. Turn the power switch OFF (O), then disconnect the power cord and test leads.
2. Remove the 8 screws that secure the legs on the rear panel, and the 2 screws used to mount the handle on the side panel.
3. Remove the top case section by sliding it to the back of the instrument.
4. Locate the battery installed at the corner of the circuit board. Insert the tip of forceps between the battery holder and battery to lift the battery for removal.

CALIFORNIA, USA ONLY
Perchlorate Material - special handling may apply.
See www.dtsc.ca.gov/hazardouswaste/perchlorate

Appendix

Appendix1 Terminology

(excerpt from IEC 60601-1:2005 3rd)

Equipment part	
TYPE B APPLIED PART 	APPLIED PART complying with the specified requirements of this standard to provide protection against electric shock, particularly regarding allowable PATIENT LEAKAGE CURRENT and PATIENT AUXILIARY CURRENT.
TYPE BF APPLIED PART 	F-TYPE APPLIED PART complying with the specified requirements of this standard to provide a higher degree of protection against electric shock than that provided by TYPE B APPLIED PARTS. NOTE:TYPE BF APPLIED PARTS are not suitable for DIRECT CARDIAC APPLICATION.
TYPE CF APPLIED PART 	F-TYPE APPLIED PART complying with the specified requirements of this standard to provide a higher degree of protection against electric shock than that provided by TYPE BF APPLIED PARTS.
F-TYPE ISOLATED APPLIED PART	F-TYPE ISOLATED (FLOATING) APPLIED PART (herein F-TYPE APPLIED PART) in which the PATIENT CONNECTIONS are isolated from other parts of the ME EQUIPMENT to such a degree that no current higher than the allowable PATIENT LEAKAGE CURRENT flows if an unintended voltage originating from an external source is connected to the PATIENT, and thereby applied between the PATIENT CONNECTION and earth. NOTE:F-TYPE APPLIED PARTS are either TYPE BF APPLIED PARTS or TYPE CF APPLIED PARTS.
ACCESSIBLE PART	part of electrical equipment other than an APPLIED PART that can be touched by means of the standard test finger.
APPLIED PART	part of ME EQUIPMENT that in NORMAL USE necessarily comes into physical contact with the PATIENT for ME EQUIPMENT or an ME SYSTEM to perform its function.
SIGNAL INPUT/OUTPUT PART(SIP/SOP)	part of ME EQUIPMENT, not being an APPLIED PART, intended to deliver or receive signals to or from other electrical equipment, for example, for display, recording or data processing.
PATIENT CONNECTION	individual point on the APPLIED PART through which current can flow between the PATIENT and the ME EQUIPMENT in NORMAL CONDITION or SINGLE FAULT CONDITION

Equipment type (classification)	
MEDICAL ELECTRICAL EQUIPMENT (ME EQUIPMENT)	electrical equipment having an APPLIED PART or transferring energy to or from the PATIENT or detecting such energy transfer to or from the PATIENT.
CLASS I	term referring to electrical equipment in which protection against electric shock does not rely on BASIC INSULATION only, but which includes an additional safety precaution in that means are provided for ACCESSIBLE PARTS of metal or internal parts of metal to be PROTECTIVELY EARTHED.
CLASS II	term referring to electrical equipment in which protection against electric shock does not rely on BASIC INSULATION only, but in which additional safety precautions such as DOUBLE INSULATION or REINFORCED INSULATION are provided, there being no provision for protective earthing or reliance upon installation conditions. NOTE:CLASS II equipment can be provided with a FUNCTIONAL EARTH TERMINAL or a FUNCTIONAL EARTH CONDUCTOR.
INTERNALLY POWERED equipment	term referring to electrical equipment that is able to operate from an INTERNAL ELECTRICAL POWER SOURCE.
MOBILE equipment	term referring to TRANSPORTABLE equipment intended to be moved from one location to another while supported by its own wheels or equivalent means.
PERMANENTLY INSTALLED	term meaning electrically connected to the SUPPLY MAINS by means of a permanent connection that can only be detached by the use of a TOOL.

Others	
BASIC INSULATION	insulation providing basic protection against electric shock NOTE:BASIC INSULATION provides one MEANS OF PROTECTION.
DOUBLE INSULATION	insulation comprising both BASIC INSULATION and SUPPLEMENTARY INSULATION NOTE:DOUBLE INSULATION provides two MEANS OF PROTECTION.
REINFORCED INSULATION	single insulation system that provides two MEANS OF PROTECTION.
SUPPLEMENTARY INSULATION	independent insulation applied in addition to BASIC INSULATION in order to provide protection against electric shock in the event of a failure of BASIC INSULATION NOTE:SUPPLEMENTARY INSULATION provides one MEANS OF PROTECTION.
PROTECTIVE EARTH CONDUCTOR	conductor to be connected between the PROTECTIVE EARTH TERMINAL and an external protective earthing system.
PROTECTIVE EARTH TERMINAL	terminal connected to conductive parts of CLASS I equipment for safety purposes. This terminal is intended to be connected to an external protective earthing system by a PROTECTIVE EARTH CONDUCTOR.

Others	
FUNCTIONAL EARTH TERMINAL	terminal, directly connected to a circuit or to a screening part, that is intended to be earthed for functional purposes.
NORMAL CONDITION	condition in which all means provided for protection against HAZARDS are intact.
SINGLE FAULT CONDITION	condition in which a single means for reducing a RISK is defective or a single abnormal condition is present.
MAXIMUM MAINS VOLTAGE	voltage used for test purposes related to the voltage of the SUPPLY MAINS and connected to certain ME EQUIPMENT parts.

Appendix2 List of instrument status, other test condition and special test condition

When network A, D, E or F is selected

Measurement mode	Class-I equipment					Class-II equipment					Internally powered equipment				
	Equipment status					Equipment status					Equipment status				
	Normal condition	Single-fault condition				Normal condition	Single-fault condition				Normal condition	Single-fault condition			
		Power cord disconnection	Grounding wire disconnection	Application of line voltage L	Application of line voltage N		Power cord disconnection	Grounding wire disconnection	Application of line voltage L	Application of line voltage N		Power cord disconnection	Grounding wire disconnection	Application of line voltage L	Application of line voltage N
Earth leakage current	○	○	-	-	-	-	-	-	-	-	-	-	-	-	-
Enclosure - Line leakage current	-	-	-	○	○	-	-	-	○	○	-	-	-	-	-
Enclosure - Earth leakage current	○	○	○	-	-	○	○	-	-	-	○	-	-	-	-
Enclosure - Enclosure current	○	○	○	-	-	○	○	-	-	-	○	-	-	-	-
Free current*	○	○	○	-	-	○	○	-	-	-	○	-	-	-	-

*Only network A
○:Can be set, -:Cannot be set

When network B1 is selected

Measurement mode	Class-I equipment					Class-II equipment					Internally powered equipment				
	Equipment status					Equipment status					Equipment status				
	Normal condition	Single-fault condition				Normal condition	Single-fault condition				Normal condition	Single-fault condition			
		Power cord disconnection	Grounding wire disconnection	Application of 110% voltage : Positive phase	Application of 110% voltage : Negative phase		Power cord disconnection	Grounding wire disconnection	Application of 110% voltage : Positive phase	Application of 110% voltage : Negative phase		Power cord disconnection	Grounding wire disconnection	Application of 110% voltage : Positive phase	Application of 110% voltage : Negative phase
Earth leakage current	○	○	-	-	-	-	-	-	-	-	-	-	-	-	-
Enclosure - Earth leakage current	○	○	○	○	○	○	○	-	○	○	○	-	-	○	○
Enclosure - Enclosure current	○	○	○	○	○	○	○	-	○	○	○	-	-	○	○
Patient auxiliary current	○	○	○	-	-	○	○	-	-	-	○	-	-	-	-
Patient leakage current I	○	○	○	-	-	○	○	-	-	-	○	-	-	-	-
Patient leakage current II (only B-type applied parts)	-	-	-	○	○	-	-	-	○	○	-	-	-	○	○
Patient leakage current III (only BF-type or CF-type applied parts)	-	-	-	○	○	-	-	-	○	○	-	-	-	○	○
Free current	○	○	○	○	○	○	○	-	○	○	○	-	-	○	○

○:Can be set, -:Cannot be set

When network C or G is selected

Measurement mode	Class-I equipment					Class-II equipment					Internally powered equipment				
	Equipment status					Equipment status					Equipment status				
	Normal condition	Single-fault condition				Normal condition	Single-fault condition				Normal condition	Single-fault condition			
		Power cord disconnection	Grounding wire disconnection	Application of line voltage L	Application of line voltage N		Power cord disconnection	Grounding wire disconnection	Application of line voltage L	Application of line voltage N		Power cord disconnection	Grounding wire disconnection	Application of line voltage L	Application of line voltage N
Earth leakage current	○	○	–	–	–	–	–	–	–	–	–	–	–	–	–
Touch current: Enclosure - Line	–	–	–	○	○	–	–	–	○	○	–	–	–	–	–
Touch current: Enclosure - Earth	○	○	○	–	–	○	○	–	–	–	○	–	–	–	–
Touch current: Enclosure - Enclosure	○	○	○	–	–	○	○	–	–	–	○	–	–	–	–
Free current	○	○	○	–	–	○	○	–	–	–	○	–	–	–	–

○:Can be set, –:Cannot be set

A6

Appendix2 List of instrument status, other test condition and special test condition

When network B2 is selected	Internally powered equipment	Special test condition (Specific applied voltage)		Application of 110% voltage:Negative phase								o	o			o	o				
				Application of 110% voltage:Positive phase							o	o			o	o					
				Other test condition (Other applied voltages)		Application of 110% voltage:Negative phase		o	o			o			o			o			
						Application of 110% voltage:Positive phase		o	o			o			o			o			
		Equipment status	Single-fault condition	Application of 110% voltage:Negative phase																	
				Application of 110% voltage:Positive phase																	
				Grounding wire disconnection																	
				Power cord disconnection																	
	Normal condition			o	o	o	o	o			o	o			o						
	Class-II equipment	Special test condition (Specific applied voltage)		Application of 110% voltage:Negative phase							o	o			o	o					
				Application of 110% voltage:Positive phase							o	o			o	o					
				Other test condition (Other applied voltages)		Application of 110% voltage:Negative phase		o	o			o			o			o			
						Application of 110% voltage:Positive phase		o	o			o			o			o			
Equipment status		Single-fault condition	Application of 110% voltage:Negative phase																		
			Application of 110% voltage:Positive phase																		
			Grounding wire disconnection																		
			Power cord disconnection		o	o	o	o	o			o	o			o					
Normal condition			o	o	o	o	o			o	o			o							
Class-I equipment	Special test condition (Specific applied voltage)		Application of 110% voltage:Negative phase							o	o			o	o						
			Application of 110% voltage:Positive phase							o	o			o	o						
			Other test condition (Other applied voltages)		Application of 110% voltage:Negative phase		o	o			o			o			o				
					Application of 110% voltage:Positive phase		o	o			o			o			o				
	Equipment status	Single-fault condition	Application of 110% voltage:Negative phase																		
			Application of 110% voltage:Positive phase																		
			Grounding wire disconnection		o	o	o	o	o			o	o			o					
			Power cord disconnection	o	o	o	o	o	o			o	o			o					
Normal condition		o	o	o	o	o	o			o	o			o							
Measurement mode				1	2	3	4	5	6	7	8	9	10	11	12	13					

o: Can be set, -: Cannot be set
 1: Earth leakage current, 2: Touch current: Enclosure - Earth, 3: Touch current: Enclosure - Earth, 4: Patient auxiliary current, 5: Patient leakage current: (Patient - Earth),
 6: Patient leakage current: Applied part (only BF-type or CF-type applied parts), 7: Patient leakage current: Metal accessible part (only B-type applied parts), 8: Total patient leakage current: (Patient - Earth), 9: Total patient leakage current: (Patient - Earth), 10: Total patient leakage current: SIP/SOP, 11: Total patient leakage current: F-type applied part (only BF-type applied parts), 12: Total patient leakage current: Metal accessible part (only B-type or BF-type applied parts), 13: Free current

Appendix3 List of default settings

Default settings for each network when the software is initialized.

Network A

After selecting network, class and leakage current mode

Leakage current mode	item	default setting		
		Class I	Class II	Internally powered
Earth leakage current	measurement	manual		
	polarity	positive phase		
	equipment status	normal		
	filter	ON		
	target current	ACDC		
	range	AUTO		
	allowable value : upper limit : normal	1.000 mA	–	–
	allowable value : upper limit : fault	1.000 mA		
	allowable value : lower limit : ON/OFF : normal	OFF		
	allowable value : lower limit : ON/OFF : fault	OFF		
Enclosure - Earth leakage current	measurement	manual	manual	–
	polarity	positive phase	positive phase	–
	equipment status	normal	normal	–
	filter	ON	ON	ON
	target current	ACDC	ACDC	ACDC
	range	AUTO	AUTO	AUTO
	allowable value : upper limit : normal	1.000 mA	1.000 mA	1.000 mA
	allowable value : upper limit : fault	1.000 mA	1.000 mA	–
	allowable value : lower limit : ON/OFF : normal	OFF	OFF	OFF
	allowable value : lower limit : ON/OFF : fault	OFF	OFF	–
Enclosure - Enclosure leakage current	measurement	manual	manual	–
	polarity	positive phase	positive phase	–
	equipment status	normal	normal	–
	filter	ON	ON	ON
	target current	ACDC	ACDC	ACDC
	range	AUTO	AUTO	AUTO
	allowable value : upper limit : normal	1.000 mA	1.000 mA	1.000 mA
	allowable value : upper limit : fault	1.000 mA	1.000 mA	–
	allowable value : lower limit : ON/OFF : normal	OFF	OFF	OFF
	allowable value : lower limit : ON/OFF : fault	OFF	OFF	–

A8

Appendix3 List of default settings

Leakage current mode	item	default setting		
		Class I	Class II	Internally powered
Enclosure - Line leakage current	measurement	manual	manual	-
	condition	L side	L side	
	Selected line	internal	internal	
	filter	ON	ON	
	target current	ACDC	ACDC	
	range	AUTO	AUTO	
	allowable value : upper limit : normal	-	-	
	allowable value : upper limit : fault	1.000 mA	1.000 mA	
	allowable value : lower limit : ON/OFF : normal	-	-	
allowable value : lower limit : ON/OFF : fault	OFF	OFF		
Free current	measurement	manual	manual	-
	polarity	positive phase	positive phase	-
	equipment status	normal	normal	-
	filter	ON	ON	ON
	target current	ACDC	ACDC	ACDC
	range	AUTO	AUTO	AUTO
	allowable value : upper limit : normal	1.000 mA	1.000 mA	1.000 mA
	allowable value : upper limit : fault	1.000 mA	1.000 mA	-
	allowable value : lower limit : ON/OFF : normal	OFF	OFF	OFF
allowable value : lower limit : ON/OFF : fault	OFF	OFF	-	

Network B1

NOTE

When network B1 is selected, measured AC+DC current does not appear on the screen. AC+DC is automatically selected internally.

After selecting network, class, applied part and leakage current mode

		default setting								
		Class I			Class II			Internally powered		
Leakage current mode	item	Type B	Type BF	Type CF	Type B	Type BF	Type CF	Type B	Type BF	Type CF
Earth leak-age current	measurement	manual			-	-	-	-	-	-
	polarity	positive phase								
	equipment status	normal								
	s10	OFF								
	s12	OFF								
	s13	-								
	filter	ON								
	target current	ACDC								
	range	AUTO								
	allowable value : upper limit : normal	500.0 μA								
	allowable value : upper limit : fault	1.000 mA								
	allowable value : lower limit : ON/ OFF : normal	OFF								
	allowable value : lower limit : ON/ OFF : fault	OFF								
Enclosure - Earth leak-age current	measurement	manual			manual			manual		
	polarity	positive phase			positive phase			-		
	equipment status	normal			normal			normal		
	s10	OFF			OFF			-		
	s12	OFF			OFF			-		
	s13	-			-			-		
	filter	ON			ON			ON		
	target current	ACDC			ACDC			ACDC		
	range	AUTO			AUTO			AUTO		
	allowable value : upper limit : normal	100.0 μA			100.0 μA			100.0 μA		
	allowable value : upper limit : fault	500.0 μA			500.0 μA			500.0 μA		
	allowable value : lower limit : ON/ OFF : normal	OFF			OFF			OFF		
	allowable value : lower limit : ON/ OFF : fault	OFF			OFF			OFF		

* () is the value after DC switching

A10

Appendix3 List of default settings

		default setting								
		Class I			Class II			Internally powered		
Leakage current mode	item	Type B	Type BF	Type CF	Type B	Type BF	Type CF	Type B	Type BF	Type CF
Enclosure - Enclosure leakage current	measurement	manual			manual			manual		
	polarity	positive phase			positive phase			-		
	equipment status	normal			normal			normal		
	s10	OFF			OFF			-		
	s12	OFF			OFF			-		
	s13	-			-			-		
	filter	ON			ON			ON		
	target current	ACDC			ACDC			ACDC		
	range	AUTO			AUTO			AUTO		
	allowable value : upper limit : normal	100.0 μ A			100.0 μ A			100.0 μ A		
	allowable value : upper limit : fault	500.0 μ A			500.0 μ A			500.0 μ A		
	allowable value : lower limit : ON/ OFF : normal	OFF			OFF			OFF		
	allowable value : lower limit : ON/ OFF : fault	OFF			OFF			OFF		
	Patient leakage current I	measurement	manual			manual			manual	
polarity		positive phase			positive phase			-		
equipment status		normal			normal			normal		
s10		OFF			OFF			-		
s12		-			-			-		
s13		OFF			OFF			-		
filter		ON			ON			ON		
target current		AC			AC			AC		
range		AUTO			AUTO			AUTO		
allowable value : upper limit : normal*		100.0 μ A (10.00 μ A)	10.0 μ A (10.00 μ A)		100.0 μ A (10.00 μ A)	10.0 μ A (10.00 μ A)		100.0 μ A (10.00 μ A)	10.0 μ A (10.00 μ A)	
allowable value : upper limit : fault*		500.0 μ A (50.00 μ A)	50.0 μ A (50.00 μ A)		500.0 μ A (50.00 μ A)	50.0 μ A (50.00 μ A)		-		
allowable value : lower limit : ON/ OFF : normal*		OFF (OFF)			OFF (OFF)			OFF (OFF)		
allowable value : lower limit : ON/ OFF : fault*		OFF (OFF)			OFF (OFF)			-		

* () is the value after DC switching

		default setting								
		Class I			Class II			Internally powered		
Leakage current mode	item	Type B	Type BF	Type CF	Type B	Type BF	Type CF	Type B	Type BF	Type CF
Patient leakage current II	measurement	manual			manual			manual		
	polarity	positive phase			positive phase			-		
	equipment status	110% applied N			110% applied N			110% applied N		
	s10	OFF			OFF			-		
	s12	-			-			-		
	s13	OFF			OFF			-		
	filter	ON			ON			ON		
	target current	ACDC			ACDC			ACDC		
	range	AUTO	-	-	AUTO	-	-	AUTO	-	-
	allowable value : upper limit : normal	-			-			-		
	allowable value : upper limit : fault	5.000 mA			5.000 mA			5.000 mA		
	allowable value : lower limit : ON/OFF : normal	-			-			-		
	allowable value : lower limit : ON/OFF : fault	OFF			OFF			OFF		
Patient leakage current III	measurement		manual			manual			manual	
	polarity		positive phase			positive phase			-	
	equipment status		110% applied N			110% applied N			110% applied N	
	s10		OFF			OFF			-	
	s12		-			-			-	
	s13		OFF			OFF			-	
	filter		ON			ON			ON	
	target current		ACDC			ACDC			ACDC	
	range		AUTO			AUTO			AUTO	
	allowable value : upper limit : normal		-			-			-	
	allowable value : upper limit : fault		5.000 mA	50.00 μ A		5.000 mA	50.00 μ A		5.000 mA	50.00 μ A
	allowable value : lower limit : ON/OFF : normal		-			-			-	
	allowable value : lower limit : ON/OFF : fault		OFF			OFF			OFF	

* () is the value after DC switching

A12

Appendix3 List of default settings

		default setting								
		Class I			Class II			Internally powered		
Leakage current mode	item	Type B	Type BF	Type CF	Type B	Type BF	Type CF	Type B	Type BF	Type CF
Patient auxiliary current	measurement	manual			manual			manual		
	polarity	positive phase			positive phase			-		
	equipment status	normal			normal			normal		
	s10	OFF			OFF			-		
	s12	-			-			-		
	s13	-			-			-		
	filter	ON			ON			ON		
	target current	AC			AC			AC		
	range	AUTO			AUTO			AUTO		
	allowable value : upper limit : normal*	100.0 μ A (10.00 μ A)		10.00 μ A (10.00 μ A)	100.0 μ A (10.00 μ A)j		10.00 μ A (10.00 μ A)j	100.0 μ A (10.00 μ A)		10.00 μ A (10.00 μ A)
	allowable value : upper limit : fault*	500.0 μ A (50.00 μ A)		50.00 μ A (50.00 μ A)	500.0 μ A (50.00 μ A)		50.00 μ A (50.00 μ A)	-		
	allowable value : lower limit : ON/ OFF : normal*	OFF (OFF)			OFF (OFF)			OFF (OFF)		
	allowable value : lower limit : ON/ OFF : Ffault*	OFF (OFF)			OFF (OFF)			-		
Free current	measurement	manual			manual			manual		
	polarity	positive phase			positive phase			-		
	equipment status	normal			normal			normal		
	s10	OFF			OFF			-		
	s12	OFF			OFF			-		
	s13	-			-			-		
	filter	ON			ON			ON		
	target current	ACDC			ACDC			ACDC		
	range	AUTO			AUTO			AUTO		
	allowable value : upper limit : normal	100.0 μ A			100.0 μ A			100.0 μ A		
	allowable value : upper limit : fault	500.0 μ A			500.0 μ A			500.0 μ A		
	allowable value : lower limit : ON/ OFF : normal	OFF			OFF			OFF		
	allowable value : lower limit : ON/ OFF : fault	OFF			OFF			OFF		

* () is the value after DC switching

Network B2

NOTE

When network B2 is selected, measured AC+DC current does not appear on the screen. AC+DC is automatically selected internally.

After selecting network, class, applied part and leakage current mode

		default setting								
		Class I			Class II			Internally powered		
Leakage current mode	item	Type B	Type BF	Type CF	Type B	Type BF	Type CF	Type B	Type BF	Type CF
Earth leakage current	measurement	manual								
	polarity	positive phase								
	equipment status	normal								
	Other applied voltages	-								
	Application of specific voltage	-								
	s10	OFF								
	s12	OFF								
	s13	-								
	filter	ON								
	target current	ACDC			-	-	-	-	-	-
	range	AUTO								
	allowable value : upper limit : normal	5.000 mA								
	allowable value : upper limit : fault	10.00 mA								
	allowable value : lower limit : ON/OFF : normal	OFF								
allowable value : lower limit : ON/OFF : fault	OFF									

* () is the value after DC switching

A14

Appendix3 List of default settings

		default setting								
		Class I			Class II			Internally powered		
Leakage current mode	item	Type B	Type BF	Type CF	Type B	Type BF	Type CF	Type B	Type BF	Type CF
Touch current (Enclosure - Earth)	measurement	manual			manual			manual		
	polarity	positive phase			positive phase			-		
	equipment status	normal			normal			normal		
	Other applied voltages	OFF			OFF			OFF		
	Application of specific voltage	-			-			-		
	s10	OFF			OFF			-		
	s12	OFF			OFF			-		
	s13	-			-			-		
	filter	ON			ON			ON		
	target current	ACDC			ACDC			ACDC		
	range	AUTO			AUTO			AUTO		
	allowable value : upper limit : normal	100.0 μ A			100.0 μ A			100.0 μ A		
	allowable value : upper limit : fault	500.0 μ A			500.0 μ A			-		
	allowable value : lower limit : ON/OFF : normal	OFF			OFF			OFF		
allowable value : lower limit : ON/OFF : fault	OFF			OFF			-			
Touch current (Enclosure-Enclosure)	measurement	manual			manual			manual		
	polarity	positive phase			positive phase			-		
	equipment status	normal			normal			normal		
	Other applied voltages	OFF			OFF			OFF		
	Application of specific voltage	-			-			-		
	s10	OFF			OFF			-		
	s12	OFF			OFF			-		
	s13	-			-			-		
	filter	ON			ON			ON		
	target current	ACDC			ACDC			ACDC		
	range	AUTO			AUTO			AUTO		
	allowable value : upper limit: normal	100.0 μ A			100.0 μ A			100.0 μ A		
	allowable value: upper limit: fault	500.0 μ A			500.0 μ A			-		
	allowable value: lower limit: ON/OFF: normal	OFF			OFF			OFF		
allowable value: lower limit: ON/OFF: fault	OFF			OFF			-			

* () is the value after DC switching

		default setting								
		Class I			Class II			Internally powered		
Leakage current mode	item	Type B	Type BF	Type CF	Type B	Type BF	Type CF	Type B	Type BF	Type CF
Patient leakage current (Patient connection - Earth)	measurement	manual			manual			manual		
	polarity	positive phase			positive phase			-		
	equipment status	normal			normal			normal		
	Other applied voltages	-			-			-		
	Application of specific voltage	-			-			-		
	measurement terminals	-			-			T2T1		
	s10	OFF			OFF			-		
	s12	-			-			-		
	s13	OFF			OFF			-		
	filter	ON			ON			ON		
	target current	AC			AC			AC		
	range	AUTO			AUTO			AUTO		
	allowable value : upper limit : normal*	100.0 μ A (10.00 μ A)	10.00 μ A (10.00 μ A)	10.00 μ A (10.00 μ A)	100.0 μ A (10.00 μ A)	10.00 μ A (10.00 μ A)	10.00 μ A (10.00 μ A)	100.0 μ A (10.00 μ A)	10.00 μ A (10.00 μ A)	10.00 μ A (10.00 μ A)
	allowable value: upper limit : fault*	500.0 μ A (50.00 μ A)	50.00 μ A (50.00 μ A)	50.00 μ A (50.00 μ A)	500.0 μ A (50.00 μ A)	50.00 μ A (50.00 μ A)	50.00 μ A (50.00 μ A)	-		
	allowable value: lower limit : ON/OFF : normal	OFF			OFF			OFF		
allowable value : lower limit : ON/OFF : fault	OFF			OFF			-			

* () is the value after DC switching

A16

Appendix3 List of default settings

		default setting								
		Class I			Class II			Internally powered		
Leakage current mode	item	Type B	Type BF	Type CF	Type B	Type BF	Type CF	Type B	Type BF	Type CF
Patient leakage current (SIP/SOP)	measurement	manual			manual			manual		
	polarity	positive phase			positive phase			-		
	equipment status	normal			normal			normal		
	Other applied voltages	110% applied N			110% applied N			110% applied N		
	Application of specific voltage	-			-			-		
	s10	OFF			OFF			-		
	s12	-			-			-		
	s13	OFF			OFF			-		
	filter	ON			ON			ON		
	target current	AC			AC			AC		
	range	AUTO			AUTO			AUTO		
	allowable value : upper limit : normal*	100.0 μ A (10.00 μ A)	10.00 μ A (10.00 μ A)	10.00 μ A (10.00 μ A)	100.0 μ A (10.00 μ A)	10.00 μ A (10.00 μ A)	10.00 μ A (10.00 μ A)	100.0 μ A (10.00 μ A)	10.00 μ A (10.00 μ A)	10.00 μ A (10.00 μ A)
	allowable value : upper limit : fault*	500.0 μ A (50.00 μ A)	50.00 μ A (50.00 μ A)	50.00 μ A (50.00 μ A)	500.0 μ A (50.00 μ A)	50.00 μ A (50.00 μ A)	50.00 μ A (50.00 μ A)	-		
	allowable value : lower limit : ON/OFF : normal	OFF			OFF			OFF		
allowable value : lower limit : ON/OFF : fault	OFF			OFF			-			

* () is the value after DC switching

		default setting								
		Class I			Class II			Internally powered		
Leakage current mode	item	Type B	Type BF	Type CF	Type B	Type BF	Type CF	Type B	Type BF	Type CF
Patient leakage current (F-type applied part)	measurement	-	manual		-	manual		-	manual	
	polarity		positive phase			positive phase			-	
	equipment status		-			-			-	
	Other applied voltages		-			-			-	
	Application of specific voltage		110% applied N			110% applied N			110% applied N	
	s10		OFF			OFF			-	
	s12		-			-			-	
	s13		OFF			OFF			-	
	filter		ON			ON			ON	
	target current		ACDC			ACDC			ACDC	
	range		AUTO			AUTO			AUTO	
	allowable value : upper limit : normal		-			-			-	
	allowable value : upper limit : fault		5.000 mA	50.00 μ A		5.000 mA	50.00 μ A		5.000 mA	50.00 μ A
	allowable value : lower limit : ON/OFF : normal		-			-			-	
	allowable value : lower limit : ON/OFF : fault		OFF			OFF			OFF	

* () is the value after DC switching

A18

Appendix3 List of default settings

		default setting								
		Class I			Class II			Internally powered		
Leakage current mode	item	Type B	Type BF	Type CF	Type B	Type BF	Type CF	Type B	Type BF	Type CF
Patient leakage current (metal accessible part)	measurement	manual			manual			manual		
	polarity	positive phase			positive phase			-		
	equipment status	-			-			-		
	Other applied voltages	-			-			-		
	Application of specific voltage	110% applied N			110% applied N			110% applied N		
	s10	OFF			OFF			-		
	s12	-			-			-		
	s13	-			-			-		
	filter	ON			ON			ON		
	target current	ACDC			ACDC			ACDC		
	range	AUTO			AUTO			AUTO		
	allowable value : upper limit : normal	-			-			-		
	allowable value : upper limit : fault	500.0 µA			500.0 µA			500.0 µA		
	allowable value : lower limit : ON/OFF : normal	-			-			-		
allowable value : lower limit : ON/OFF : fault	OFF			OFF			OFF			

* () is the value after DC switching

		default setting								
		Class I			Class II			Internally powered		
Leakage current mode	item	Type B	Type BF	Type CF	Type B	Type BF	Type CF	Type B	Type BF	Type CF
Total patient leakage current (Patient - Earth)	measurement	manual			manual			manual		
	polarity	positive phase			positive phase			-		
	equipment status	normal			normal			normal		
	Other applied voltages	-			-			-		
	Application of specific voltage	-			-			-		
	measurement terminals	-			-			T2T1		
	s10	OFF			OFF			-		
	s12	-			-			-		
	s13	OFF			OFF			-		
	filter	ON			ON			ON		
	target current	AC			AC			AC		
	range	AUTO			AUTO			AUTO		
	allowable value : upper limit : normal*	500.0 μ A (50.00 μ A)	50.00 μ A (50.00 μ A)		500.0 μ A (50.00 μ A)	50.00 μ A (50.00 μ A)		500.0 μ A (50.00 μ A)	50.00 μ A (50.00 μ A)	
	allowable value : upper limit : fault*	1.000 mA (100.0 μ A)	100.0 μ A (100.0 μ A)		1.000 mA (100.0 μ A)	100.0 μ A (100.0 μ A)		-		
	allowable value : lower limit : ON/OFF : normal	OFF			OFF			OFF		
	allowable value : lower limit : ON/OFF : fault	OFF			OFF			-		

* () is the value after DC switching

A20

Appendix3 List of default settings

		default setting								
		Class I			Class II			Internally powered		
Leakage current mode	item	Type B	Type BF	Type CF	Type B	Type BF	Type CF	Type B	Type BF	Type CF
Total patient leakage current (SIP/SOP)	measurement	manual			manual			manual		
	polarity	positive phase			positive phase			-		
	equipment status	normal			normal			normal		
	Other applied voltages	110% applied N			110% applied N			110% applied N		
	Application of specific voltage	-			-			-		
	s10	OFF			OFF			-		
	s12	-			-			-		
	s13	OFF			OFF			-		
	filter	ON			ON			ON		
	target current	AC			AC			AC		
	range	AUTO			AUTO			AUTO		
	allowable value : upper limit : normal*	500.0 μ A (50.00 μ A)	50.00 μ A (50.00 μ A)	50.00 μ A (50.00 μ A)	500.0 μ A (50.00 μ A)	50.00 μ A (50.00 μ A)	50.00 μ A (50.00 μ A)	500.0 μ A (50.00 μ A)	50.00 μ A (50.00 μ A)	50.00 μ A (50.00 μ A)
	allowable value : upper limit : fault*	1.000 mA (100.0 μ A)	100.0 μ A (100.0 μ A)	100.0 μ A (100.0 μ A)	1.000 mA (100.0 μ A)	100.0 μ A (100.0 μ A)	100.0 μ A (100.0 μ A)	-		
	allowable value : lower limit : ON/OFF : normal	OFF			OFF			OFF		
allowable value : lower limit : ON/OFF : fault	OFF			OFF			-			

* () is the value after DC switching

		default setting								
		Class I			Class II			Internally powered		
Leakage current mode	item	Type B	Type BF	Type CF	Type B	Type BF	Type CF	Type B	Type BF	Type CF
Total patient leakage current (F-type applied part)	measurement	-	manual		-	manual		-	manual	
	polarity		positive phase			positive phase			-	
	equipment status		-			-			-	
	Other applied voltages		-			-			-	
	Application of specific voltage		110% applied N			110% applied N			110% applied N	
	s10		OFF			OFF			-	
	s12		-			-			-	
	s13		OFF			OFF			-	
	filter		ON			ON			ON	
	target current		ACDC			ACDC			ACDC	
	range		AUTO			AUTO			AUTO	
	allowable value : upper limit: normal		-			-			-	
	allowable value: upper limit: fault		5.000 mA	100.0 μA		5.000 mA	100.0 μA		5.000 mA	100.0 μA
	allowable value: lower limit : ON/OFF: normal		-			-			-	
	allowable value: lower limit: ON/OFF: fault		OFF			OFF			OFF	
Total patient leakage current (metal accessible part)	measurement	manual		-	manual		-	manual		
	polarity	positive phase			positive phase			-		
	equipment status	-			-			-		
	Other applied voltages	-			-			-		
	Application of specific voltage	110% applied N			110% applied N			110% applied N		
	s10	OFF			OFF			-		
	s12	-			-			-		
	s13	-			-			-		
	filter	ON			ON			ON		
	target current	ACDC			ACDC			ACDC		
	range	AUTO			AUTO			AUTO		
	allowable value : upper limit : normal	-			-			-		
	allowable value : upper limit : fault	1.000 mA			1.000 mA			1.000 mA		
	allowable value : lower limit : ON/OFF : normal	-			-			-		
	allowable value : lower limit : ON/OFF : fault	OFF			OFF			OFF		

* () is the value after DC switching

A22

Appendix3 List of default settings

		default setting								
		Class I			Class II			Internally powered		
Leakage current mode	item	Type B	Type BF	Type CF	Type B	Type BF	Type CF	Type B	Type BF	Type CF
Patient auxiliary current	measurement	manual			manual			manual		
	polarity	positive phase			positive phase			-		
	equipment status	normal			normal			normal		
	Other applied voltages	-			-			-		
	Application of specific voltage	-			-			-		
	s10	OFF			OFF			-		
	s12	-			-			-		
	s13	-			-			-		
	filter	ON			ON			ON		
	target current	AC			AC			AC		
	range	AUTO			AUTO			AUTO		
	allowable value : upper limit : normal*	100.0 μ A (10.00 μ A)	10.00 μ A (10.00 μ A)	10.00 μ A (10.00 μ A)	100.0 μ A (10.00 μ A)	10.00 μ A (10.00 μ A)	10.00 μ A (10.00 μ A)	100.0 μ A (10.00 μ A)	10.00 μ A (10.00 μ A)	10.00 μ A (10.00 μ A)
	allowable value : upper limit : fault*	500.0 μ A (50.00 μ A)	50.00 μ A (50.00 μ A)	50.00 μ A (50.00 μ A)	500.0 μ A (50.00 μ A)	50.00 μ A (50.00 μ A)	50.00 μ A (50.00 μ A)	-		
	allowable value : lower limit : ON/OFF : normal	OFF			OFF			OFF		
allowable value : lower limit : ON/OFF : fault	OFF			OFF			-			

* () is the value after DC switching

		default setting								
		Class I			Class II			Internally powered		
Leakage current mode	item	Type B	Type BF	Type CF	Type B	Type BF	Type CF	Type B	Type BF	Type CF
Free current	measurement	manual			manual			manual		
	polarity	positive phase			positive phase			-		
	equipment status	normal			normal			normal		
	Other applied voltages	OFF			OFF			OFF		
	Application of specific voltage	-			-			-		
	s10	OFF			OFF			-		
	s12	OFF			OFF			-		
	s13	-			-			-		
	filter	ON			ON			ON		
	target current	ACDC			ACDC			ACDC		
	range	AUTO			AUTO			AUTO		
	allowable value : upper limit : normal	100.0 μ A			100.0 μ A			100.0 μ A		
	allowable value : upper limit : fault	500.0 μ A			500.0 μ A			-		
	allowable value : lower limit : ON/OFF : normal	OFF			OFF			OFF		
allowable value : lower limit : ON/OFF : fault	OFF			OFF			-			

* () is the value after DC switching

Network C

After selecting network and leakage current mode

Leakage current mode	item	default setting		
		Class I	Class II	Internally powered
Earth leakage current	measurement	manual		
	polarity	positive phase		
	equipment status	normal		
	filter	ON1		
	target current	ACDC		
	range	AUTO		
	allowable value : upper limit : normal	3.500 mA	-	-
	allowable value : upper limit : fault	3.500 mA		
	allowable value : lower limit : ON/OFF : normal	OFF		
	allowable value : lower limit : ON/OFF : fault	OFF		
Touch current (Enclosure - Earth)	measurement	manual	manual	-
	polarity	positive phase	positive phase	-
	equipment status	normal	normal	-
	filter	ON1_U2	ON1_U2	ON1_U2
	target current	ACDC	ACDC	ACDC
	range	AUTO	AUTO	AUTO
	allowable value : upper limit : normal	3.500 mA	250.0 μA	250.0 μA
	allowable value : upper limit : fault	3.500 mA	250.0 μA	-
	allowable value : lower limit : ON/OFF : normal	OFF	OFF	OFF
	allowable value : lower limit : ON/OFF : fault	OFF	OFF	-
Touch current (Enclosure - Enclosure)	measurement	manual	manual	-
	polarity	positive phase	positive phase	-
	equipment status	normal	normal	-
	filter	ON1_U2	ON1_U2	ON1_U2
	target current	ACDC	ACDC	ACDC
	range	AUTO	AUTO	AUTO
	allowable value : upper limit : normal	3.500 mA	250.0 μA	250.0 μA
	allowable value : upper limit : fault	3.500 mA	250.0 μA	-
	allowable value : lower limit : ON/OFF : normal	OFF	OFF	OFF
	allowable value : lower limit : ON/OFF : fault	OFF	OFF	-

* () is the value after DC switching

Leakage current mode	item	default setting		
		Class I	Class II	Internally powered
Touch current (Enclosure - Line)	measurement	manual	manual	-
	condition	L side	L side	
	Selected line	internal	internal	
	filter	ON1_U2	ON1_U2	
	target current	ACDC	ACDC	
	range	AUTO	AUTO	
	allowable value : upper limit : normal	-	-	
	allowable value : upper limit : fault	3.500 mA	250.0 μ A	
	allowable value : lower limit : ON/OFF : normal	-	-	
allowable value : lower limit : ON/OFF : fault	OFF	OFF		
Free current	measurement	manual	manual	-
	polarity	positive phase	positive phase	-
	equipment status	normal	normal	-
	filter	ON1_U2	ON1_U2	ON1_U2
	target current	ACDC	ACDC	ACDC
	range	AUTO	AUTO	AUTO
	allowable value : upper limit : normal	3.500 mA	250.0 μ A	250.0 μ A
	allowable value : upper limit : fault	3.500 mA	250.0 μ A	-
	allowable value : lower limit : ON/OFF : normal	OFF	OFF	OFF
allowable value : lower limit : ON/OFF : fault	OFF	OFF	-	

* () is the value after DC switching

Network D/E/F

After selecting network, class, applied part and leakage current mode

Leakage current mode	item	default setting		
		Class I	Class II	Internally powered
Earth leakage current	measurement	manual	-	-
	polarity	positive phase		
	equipment status	normal		
	filter	-		
	target current	ACDC		
	range	AUTO		
	allowable value : upper limit : normal	3.500 mA		
	allowable value : upper limit : fault	3.500 mA		
	allowable value : lower limit : ON/OFF : normal	OFF		
	allowable value : lower limit : ON/OFF : fault	OFF		
Enclosure - Earth leakage current	measurement	manual	manual	-
	polarity	positive phase	positive phase	-
	equipment status	normal	normal	-
	filter	-	-	-
	target current	ACDC	ACDC	ACDC
	range	AUTO	AUTO	AUTO
	allowable value : upper limit : normal	3.500 mA	3.500 mA	3.500 mA
	allowable value : upper limit : fault	3.500 mA	3.500 mA	-
	allowable value : lower limit : ON/OFF : normal	OFF	OFF	OFF
	allowable value : Flower limit : ON/OFF : fault	OFF	OFF	-
Enclosure - Enclosure leakage current	measurement	manual	manual	-
	polarity	positive phase	positive phase	-
	equipment status	normal	normal	-
	filter	-	-	-
	target current	ACDC	ACDC	ACDC
	range	AUTO	AUTO	AUTO
	allowable value : upper limit : normal	3.500 mA	3.500 mA	3.500 mA
	allowable value : upper limit : fault	3.500 mA	3.500 mA	-
	allowable value : lower limit : ON/OFF : normal	OFF	OFF	OFF
	allowable value : lower limit : ON/OFF : fault	OFF	OFF	-
Enclosure - Line leakage current	measurement	manual	manual	-
	condition	L side	L side	
	Selected line	internal	internal	
	filter	OFF	OFF	
	target current	ACDC	ACDC	
	range	AUTO	AUTO	
	allowable value : upper limit : normal	-	-	
	allowable value : upper limit : fault	3.500 mA	3.500 mA	
	allowable value : lower limit : ON/OFF : normal	-	-	
	allowable value : lower limit : ON/OFF : fault	OFF	OFF	

* () is the value after DC switching

Network G

After selecting network, class, applied part and leakage current mode

Leakage current mode	item	default setting		
		Class I	Class II	Internally powered
Earth leakage current	measurement	manual	-	-
	polarity	positive phase		
	equipment status	normal		
	filter	OFF		
	target current	ACDC		
	range	AUTO		
	allowable value : upper limit : normal	500.0 μ A		
	allowable value : upper limit : fault	3.500 mA		
	allowable value : lower limit : ON/OFF : normal	OFF		
	allowable value : lower limit : ON/OFF : fault	OFF		
Touch current (Enclosure - Earth)	measurement	manual	manual	-
	polarity polarity	positive phase	positive phase	-
	equipment status	normal	normal	-
	filter	OFF	OFF	OFF
	target current	ACDC	ACDC	ACDC
	range	AUTO	AUTO	AUTO
	allowable value : upper limit : normal	500.0 μ A	500.0 μ A	500.0 μ A
	allowable value : upper limit : fault	3.500 mA	3.500 mA	-
	allowable value : lower limit : ON/OFF : normal	OFF	OFF	OFF
	allowable value : lower limit : ON/OFF : fault	OFF	OFF	-
Touch current (Enclosure - Enclosure)	measurement	manual	manual	-
	polarity	positive phase	positive phase	-
	equipment status	normal	normal	-
	filter	OFF	OFF	OFF
	target current	ACDC	ACDC	ACDC
	range	AUTO	AUTO	AUTO
	allowable value : upper limit : normal	500.0 μ A	500.0 μ A	500.0 μ A
	allowable value : upper limit : fault	3.500 mA	3.500 mA	-
	allowable value : lower limit : ON/OFF : normal	OFF	OFF	OFF
	allowable value : lower limit : ON/OFF : fault	OFF	OFF	-

* () is the value after DC switching

A28

Appendix3 List of default settings

Leakage current mode	item	default setting		
		Class I	Class II	Internally powered
Touch current (Enclosure - Line)	measurement	manual	manual	-
	condition	L side	L side	
	Selected line	internal	internal	
	filter	OFF	OFF	
	target current	ACDC	ACDC	
	range	AUTO	AUTO	
	allowable value : upper limit : normal	-	-	
	allowable value : upper limit : fault	3.500 mA	3.500 mA	
	allowable value : lower limit : ON/OFF : normal	-	-	
	allowable value : lower limit : ON/OFF : fault	OFF	OFF	

* () is the value after DC switching

Initializing item

item	default setting
Mode setting	Voltmeter:range AUTO voltage AC+DC Protective conductor ammeter:Range 50 mA Current AC+DC
Save data	No data
Panel Load	No data
Language	not initialize
Connect/VA Check	The connection/VA check at each power ON operation
Relay Check	Check at each power ON operation
Fuse Check	Check at each power ON operation
Polarity Change	Previous
Frequency Range	15 Hz
Auto Measure	Last Measurement State
Indication Unit	AUTO
Date/Time	not initialize
Interface	USB
Beep	Key input:ON Judgement:FAIL 110% voltage output:ON Output terminal T2:ON
Back Light	Constant ON

Appendix4 External Dimensions

(Unit: mm)

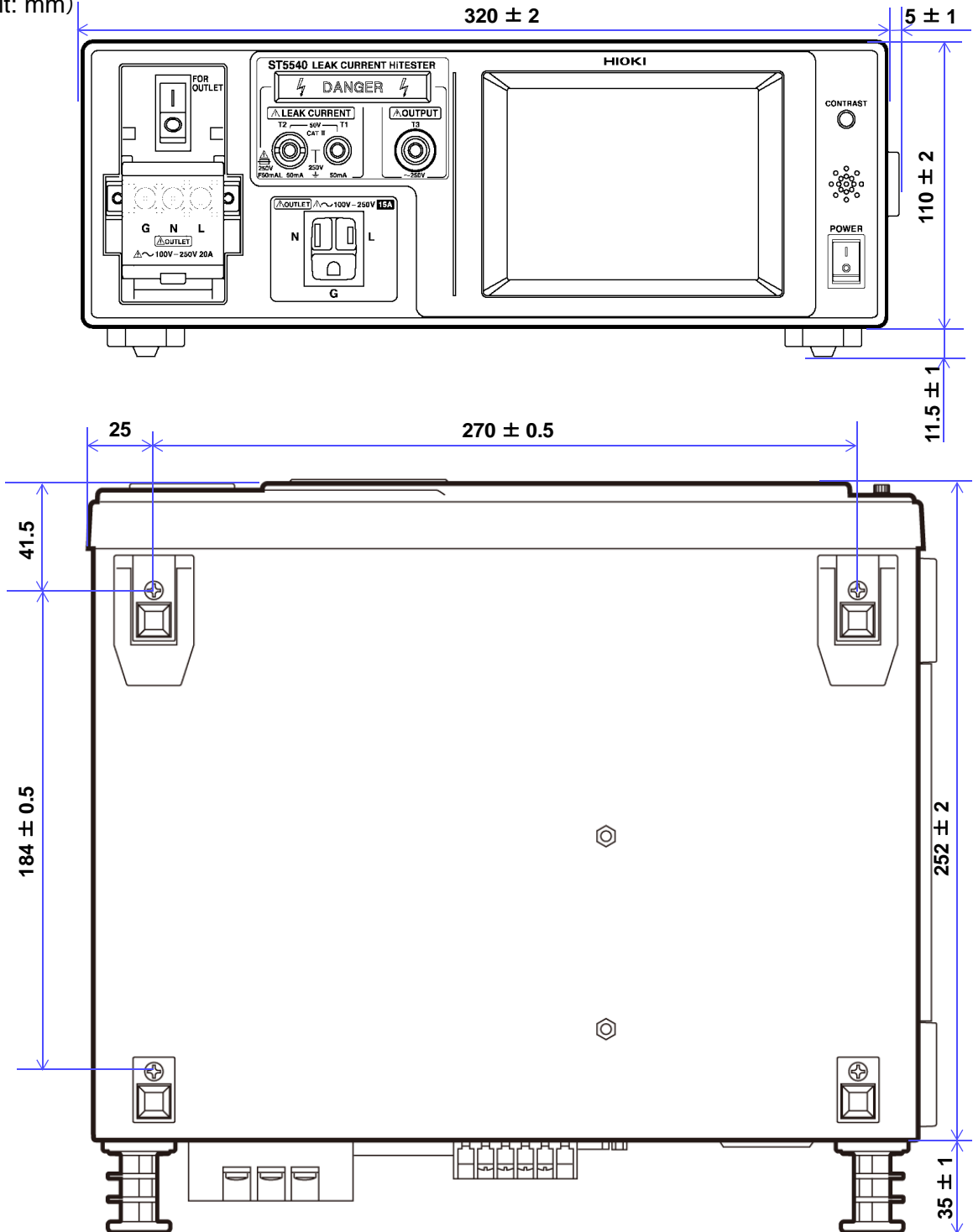

Index

Number

110% voltage application	85, 87
110% voltage output terminal	24
9195 Enclosure Probe	77

A

AC	64
Accuracy	4, 258, 259, 266
Allowable value	29, 61, 131, 135, 178
Ammeter mode	55, 57
Applied part	49
Auto	29, 54, 67
Automatic measurement	157, 167
Automatic measurement items	68

B

Back light	116, 136, 225
beep sound	135, 225

C

Circuit breaker	24
Class-I	49
Class-II	49
Connecting	31, 75, 247
Control Number	50
Current consumption	44

D

date	227
Date/Time	116
DC	64
Deleting Saved Data	105
Disposal	283

E

Earth leakage current	12
Earth leakage current measurement	83
Enclosure Probe	2
Equipment name	49, 50
Event register	159

F

Filter	29, 59
Free current measurement(Enclosure - Enclosure)	101
Frequency Range	116
Fuse	42
Fuse Check	116, 123, 238
Fuses	9, 266, 282

G

General Specifications	266
Grounding Class	49

H

Header	159
Hold	54

I

Initialization	122
Initialize	116
Initializing	121
Instrument Labels and Functions	24
Interface	116, 133, 265
Internally powered equipment	49
Isolation transformer	34

K

Key lock	247, 264
----------------	----------

L

L2200 Test Lead	2, 77, 267
Leakage Current	10
Leakage current between enclosure and line	69

M

Manual	67
Manual measurement	156
measurement delay	70
Measurement mode	51, 155
Measurement range	29, 54, 255
measuring time	73
Messages Specific to the HiTESTER	154

N

Negative phase	68, 80
Network	48, 155, 259, 269
nointerrupted performance check	127
Normal condition	61, A3

P

Panel Load	116, 120
Patient auxiliary current measurement	99
patient leakage current I	90
Patient leakage current measurement (external voltage on a SIP/SOP)	16
Patient leakage current measurement (external voltage on a specific F-type applied part)	17
Patient leakage current measurement (external voltage on metal accessible part not protectively earthed)	18
Patient leakage current measurement (Patient connection - Earth)	15
Patient leakage current measurement* (external voltage on a SIP/SOP)	93
Patient leakage current measurement* (external voltage on a specific F-type applied part)	95
Patient leakage current measurement* (external voltage on metal accessible part not protectively earthed)	97
Patient leakage current measurement* (Patient connection - Earth)	90
Peak Over	58
Polarity Change	116
Polarity Switching	22, 261
Positive phase	68, 80
Power consumption	44
Power inlet	25
Power On Polarity Switching	126
pre-check	88, 89

R

Relay check	41, 116, 128, 239
Repair	280
RS-232C	144

S

S10, S12 and S13	35, 80, 200
save	29
Saved data	158
Self-test	116, 124, 164
Single-fault condition	61
Size	266
Specifications	255
Storage	266

System	159, 263
--------------	----------

T

Target current	29, 64, 190
terminal	36
Terminal block	24, 33
Time	70
Timing Chart	251
Total patient leakage current measurement	19
Total patient leakage(current measurement) ...	100
Types of Leakage Current	12
Types of Leakage Current Measurement	13

U

Unit of current measurement	57
USB	133, 140, 144

V

Voltmeter mode	158
----------------------	-----

W

Wiring adapter	37
----------------------	----

Warranty Certificate

HIOKI

Model	Serial No.	Warranty period One (1) year from date of purchase (___ / ___)
<p>This product passed a rigorous inspection process at Hioki before being shipped.</p> <p>In the unlikely event that you experience an issue during use, please contact the distributor from which you purchased the product, which will be repaired free of charge subject to the provisions of this Warranty Certificate. This warranty is valid for a period of one (1) year from the date of purchase. If the date of purchase is unknown, the warranty is considered valid for a period of one (1) year from the product's date of manufacture. Please present this Warranty Certificate when contacting the distributor. Accuracy is guaranteed for the duration of the separately indicated guaranteed accuracy period.</p> <ol style="list-style-type: none">1. Malfunctions occurring during the warranty period under conditions of normal use in conformity with the Instruction Manual, product labeling (including stamped markings), and other precautionary information will be repaired free of charge, up to the original purchase price. Hioki reserves the right to decline to offer repair, calibration, and other services for reasons that include, but are not limited to, passage of time since the product's manufacture, discontinuation of production of parts, or unforeseen circumstances.2. Malfunctions that are determined by Hioki to have occurred under one or more of the following conditions are considered to be outside the scope of warranty coverage, even if the event in question occurs during the warranty period:<ol style="list-style-type: none">a. Damage to objects under measurement or other secondary or tertiary damage caused by use of the product or its measurement resultsb. Malfunctions caused by improper handling or use of the product in a manner that does not conform with the provisions of the Instruction Manualc. Malfunctions or damage caused by repair, adjustment, or modification of the product by a company, organization, or individual not approved by Hiokid. Consumption of product parts, including as described in the Instruction Manuale. Malfunctions or damage caused by transport, dropping, or other handling of the product after purchasef. Changes in the product's appearance (scratches on its enclosure, etc.)g. Malfunctions or damage caused by fire, wind or flood damage, earthquakes, lightning, power supply anomalies (including voltage, frequency, etc.), war or civil disturbances, radioactive contamination, or other acts of Godh. Damage caused by connecting the product to a networki. Failure to present this Warranty Certificatej. Failure to notify Hioki in advance if used in special embedded applications (space equipment, aviation equipment, nuclear power equipment, life-critical medical equipment or vehicle control equipment, etc.)k. Other malfunctions for which Hioki is not deemed to be responsible <p>*Requests</p> <ul style="list-style-type: none">• Hioki is not able to reissue this Warranty Certificate, so please store it carefully.• Please fill in the model, serial number, and date of purchase on this form. <p style="text-align: right;">16-01 EN</p>		
HIOKI E.E. CORPORATION 81 Koizumi, Ueda, Nagano 386-1192, Japan TEL: +81-268-28-0555 FAX: +81-268-28-0559		