

SMART WATCH

User Manual



This app is not a medical device. Data obtained during the use of this app is for reference only, and should not be used for clinical diagnosis, medical research, diagnostic, or treatment purposes.

1.PRODUCT INTRODUCTION & BUTTON DEFINITIONS

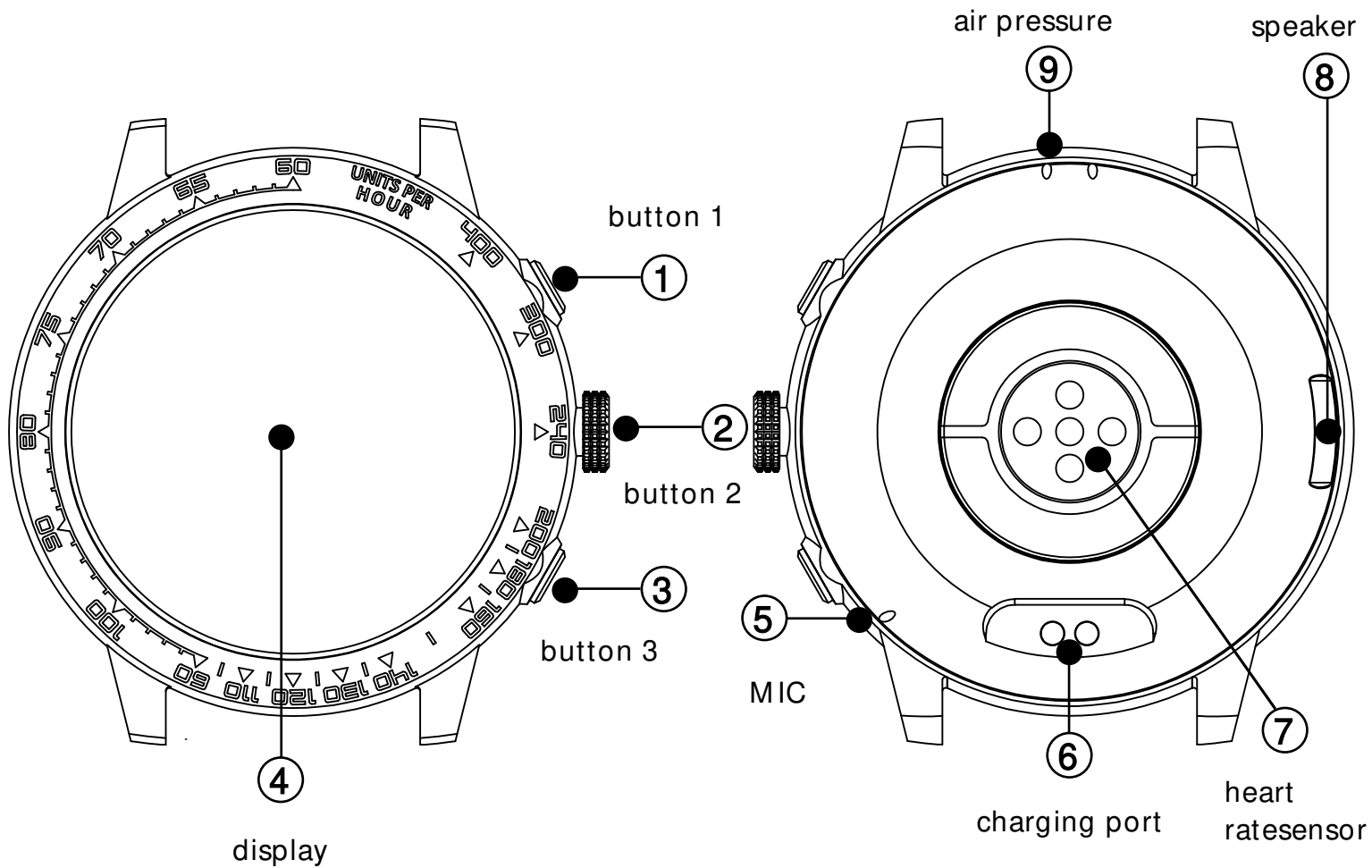

Button ① definition:

Short press: short press once on the dial interface to enter the function menu
Short press once on other function interfaces to return to the menu interface,
short press again to return to the dial interface ,

Long press for 2 seconds: enter the language assistant ,

Button ② definition:

Short press: screen off/on, one-click return to the dial interface ,

Long press: enter the shutdown, restart, SOS function interface, long press to turn on the device when it is off ,

Button ③ definition:

Shortcut key: short press to enter sports mode ,

2.TOUCH SCREEN CONTROL DEFINITIONS

On the watch face interface, press and hold the watch face for 2-3 seconds to switch watch faces. Swipe left or right to switch watch faces, and click to select a watch face.

Down: Slide the dial interface downward to open the status bar.

Up: Slide the dial interface upward to enter the quick card.

Left: Slide the dial interface to the left to enter the menu function.

Right: Slide the dial interface to the right to enter the notification information interface.

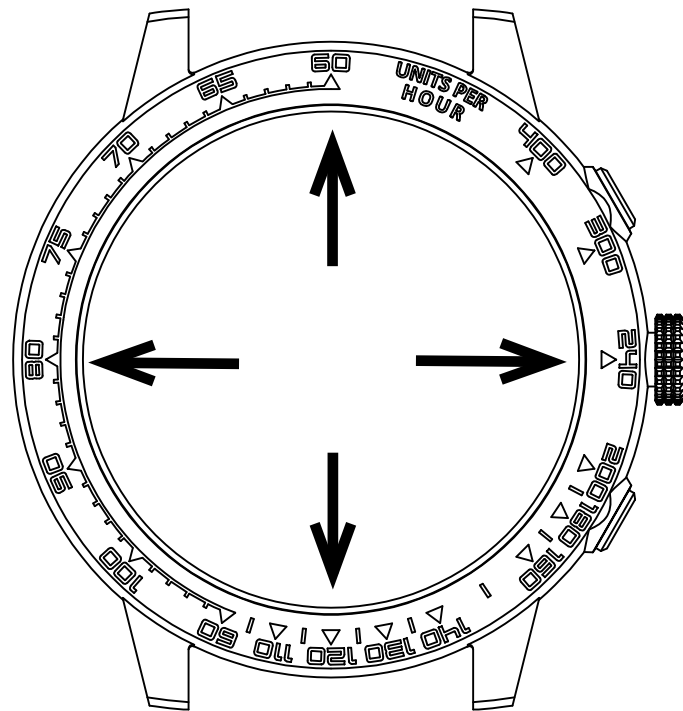

3.CHARGING

1. When the watch prompts that the battery is low, please charge it in time. The charging time is 2-3 hours.

2. The watch is magnetically charged. Align the charging contacts of the charging cable to the charging port of the watch to charge until the watch screen displays the charging prompt.

3. When charging, in order to ensure stable charging, the watch will turn off the screen to charge. Click the button to wake up the watch. When the battery of the watch is too low, it takes 3-5 minutes to wake up the watch. This is normal. Please wait for 5 minutes before checking the charging status of the watch.

4. Please use a charger with a rated output voltage of 5V and a rated output current of 0.5A-2A or a computer USB port to charge the watch.

5. When the watch is not used for a long time, please fully charge it and turn it off for storage. Do not store it for a long time in a low-power state. To avoid damaging the battery due to long-term low-power storage.

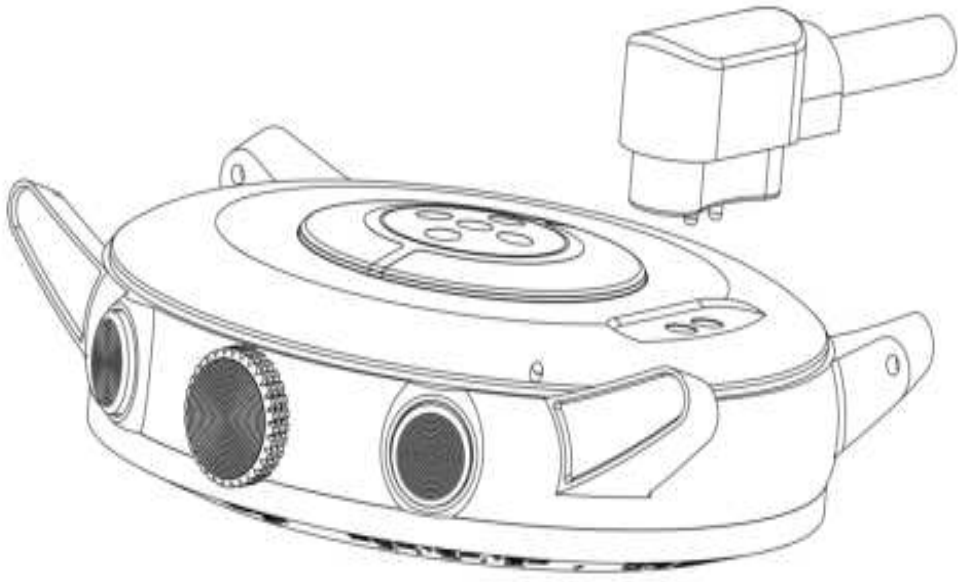

6.APP CONNECTION

Scan the watch QR code or go to major application markets to download and install the "GloryFitPro" APP. When you open the APP for the first time, a permission pop-up window will pop up. Please click "Allow" to ensure that the APP can obtain the corresponding permissions.

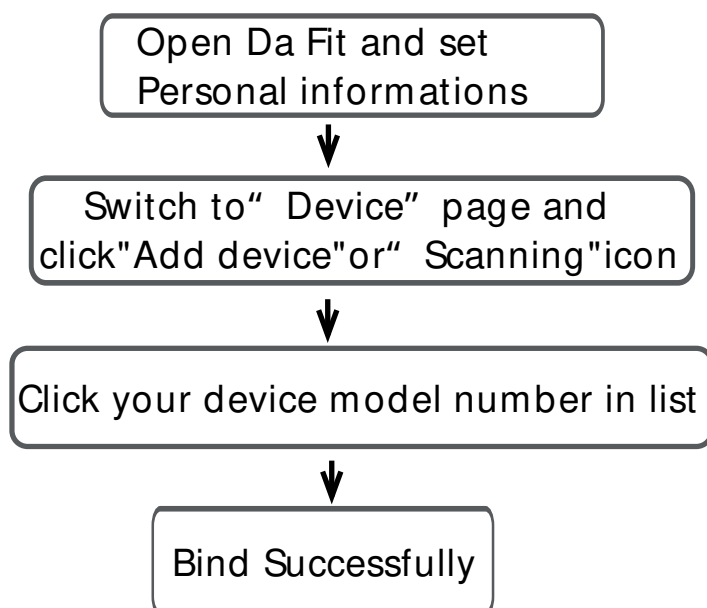

Scan Watch QR Code

During the connection process, a pop-up window will pop up to confirm the pairing connection between the watch and the phone. Click to confirm that the pairing connection is successful. The call icon and data connection icon in the watch status bar will turn green. Gray means that the connection is not successful.



7.UNBINDING APP

IOS: Find "Unbind" in the "Device" interface of the APP and click on it to enter the "Settings-Bluetooth" interface of the mobile phone system. Click on the ! on the right of the device and select "Forget this device" to unbind it from the mobile phone system. Make sure it is no longer connected to the mobile phone, otherwise it will not be able to connect again next time.

Android: Find "Unbind" in the "Device" interface of the APP and click on it to disconnect from the mobile phone

8.NOTES

- 1, Prohibit charging in the case of water damage.
- 2, This device is not a medical device, the data and information provided are for reference only.
- 3, Hot water shower or sauna etc. can not be worn to prevent water vapor intrusion. If the watch is damaged by water ingress due to use not according to the instructions, we will not provide free warranty.
- 4, Do not place the device in direct sunlight, such as car dashboard or window sill.
- 5, Do not place the device close to heat sources or naked flame sources, such as induction cookers, microwave ovens, ovens, water heaters, stoves, candles, or other places where high temperatures may be generated.
- 6, Please do not allow children or pets to swallow or bite the equipment or its accessories, so as not to cause injury to them or lead to equipment failure.
- 7, This equipment is not a toy, children should use the equipment under adult supervision.

8, This device is equipped with a non-removable built-in battery, please do not replace the battery by yourself.

9, If the watch has been in contact with water, after leaving the water source, please dry the water stains on the watch surface in a timely manner. If there is too much residual water stains in the sound chamber of the speaker and it is not discharged in time, the sound effect may be affected. Please find the sound hole of the speaker and shake out the residual water in the sound cavity in time.

FCC Caution :

FCC Statement

This device complies with part 15 of the FCC rules. Operation is subject to the following two conditions: (1) this device may not cause harmful interference, and (2) this device must accept any interference received, including interference that may cause undesired operation.

Changes or modifications not expressly approved by the party responsible for compliance could void the user's authority to operate the equipment.

NOTE: This equipment has been tested and found to comply with the limits for a Class B digital device, pursuant to part 15 of the FCC Rules. These limits are designed to provide reasonable protection against harmful interference in a residential installation. This equipment generates and can radiate radio frequency energy and, if not installed and used in accordance with the instructions, may cause harmful interference to radio communications. However, there is no guarantee that interference will not occur in a particular installation. If this equipment does cause harmful interference to radio or television reception, which can be determined by turning the equipment off and on, the user is encouraged to try to correct the interference by one or more of the following measures:

- Reorient or relocate the receiving antenna.
- Increase the separation between the equipment and receiver.
- Connect the equipment into an outlet on a circuit different from that to which the receiver is connected.
- Consult the dealer or an experienced radio/TV technician for help.

The device has been evaluated to meet general RF exposure requirement. The device can be used in portable exposure condition without restriction.