

LAGUNA

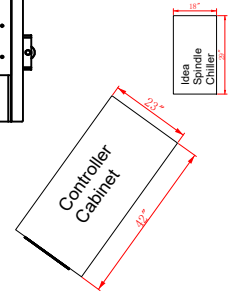

4'x8' _ 36"

SMARTSHOP | 5 axis

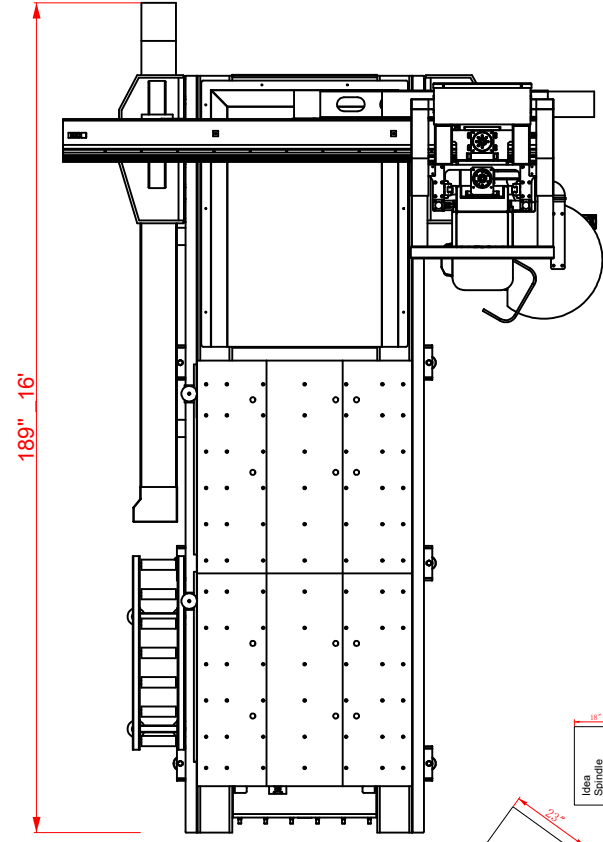
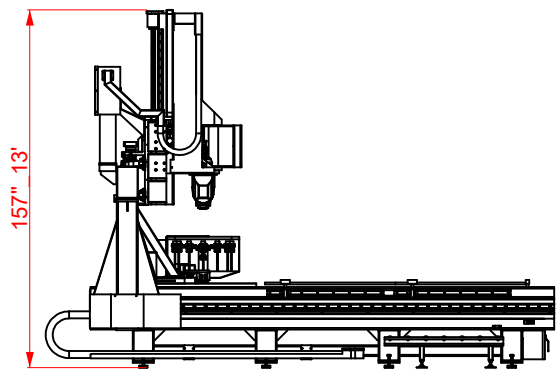

SPECIFICATION:		DRAWN.S.B. 8/28/2025_REV.1
POWER REQUIREMENTS.	See Below,varies on vacuum choice.	
FOOTPRINT.	135" W X 189" L	
WORKING AREA.	49" x 97"	
GANTRY CLEARANCE.	36"	
ARTICULATING SPINDLE HEAD.	12HP HSD HS300 2 Axis, 9 HP	
SPINDLE RPM.	5,000-18,000	
RAPID TRAVEL.	Up to 3000 IPM	
MAXIMUM CUTTING SPEED.	1200 IPM	
DUST PORT DIAMETER.	N/A	
PRECISION HELICAL RACK & PINION.	30MM HEAVY DUTY LINEAR BEARING,ALL AXES	
DRIVE SYSTEM FOR X AND Y AXES	FANUC 311-B5 with Data Server	
CONTROLLER.	FANUC, 1500W SERVO SYSTEM	
SERVO MOTORS	YES	
SOLID STATE HOME SWITCH'S.	YES	
HEAVY DUTY WELDMENT TUBULAR STEEL FRAME.	8000 POUNDS	
CENTRALIZED LUBRICATION SYSTEM FOR ALL AXES.	YES	
VACUUM TABLE	6 ZONES , POD ready NEMI standard	
TOOL CONE STYLE	HSK63F	
TOOL CAPACITY	12 Position Rotary Tool Changer	
BORING BLOCK CAPABLE	YES, 5X5 HSD Boring Block(Optional)	
VACUUM OPTIONS:	MACHINE POWER BASED ON VACUUM CHOICE	
1 pcs,10hp stock regen vacuum_3 phase	220v,3 Phase,60 amps	
1 pcs,10hp Becker SV400 vacuum_3 phase	220v,3 Phase,60 amps	
1 pcs,8.6hp Becker Vane vacuum_3 Phase	220v,3 Phase,60 amps	
1 pcs,12hp Becker Vane vacuum_3 Phase	Remote starter needed, 220v,3ph,45 amps. Optional, 480v,3ph,30 amps. CNC Motion 220v,3 phase,30 amps	

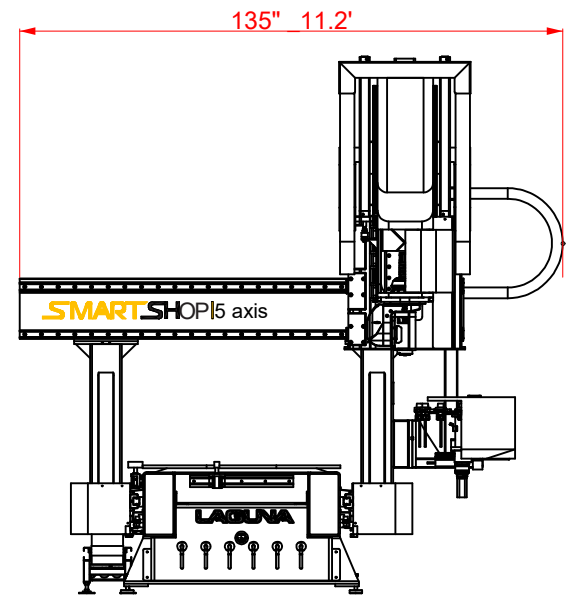

5-AXIS, 4'x8', 36" GANTRY
 LAGUNATOOLS, GRAND PRAIRIE, TEXAS
 8/26/2025, S.B., REV,1