

CLOSE COUPLED WC

FITTING INSTRUCTIONS

This product must be installed by a qualified fitter or plumber in accordance with and meet the requirements of Water Supply (Water Fittings) Regulations 1999, the Water Supply (Water Fittings) (Scotland) Byelaws 2014 and the Water Supply (Water Fittings) Regulations (Northern Ireland) 2009

INSTALLATION OF FLUSH VALVE

Turn the flush valve body anti-clockwise to part it from the flush valve cradle

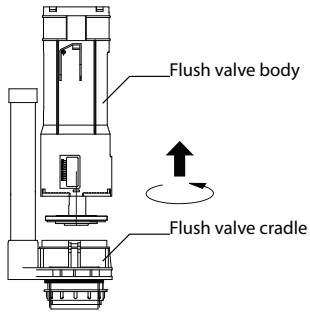

Install flush valve cradle and seal as shown

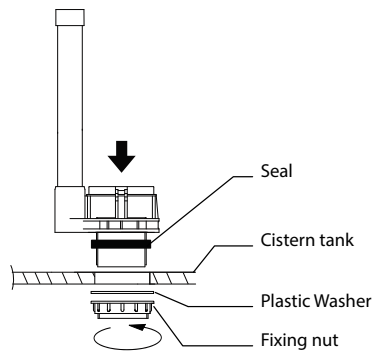

Insert flush valve body into flush valve cradle, turn it clockwise until you hear a "click"

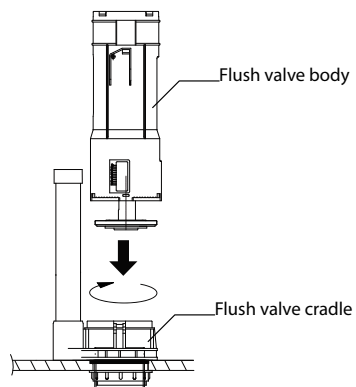

INSTALLATION OF FILL VALVE

Install the fill valve to the tank body using the rubber seal and plastic nut. Ensure the float cup has room to move up and down freely. The fill valve is pre-set to a height suitable for the cistern tank

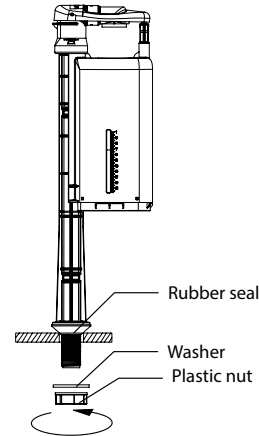

FILL VALVE ADJUSTMENT

The fill valve is factory set but if adjustment is required follow the instructions below.

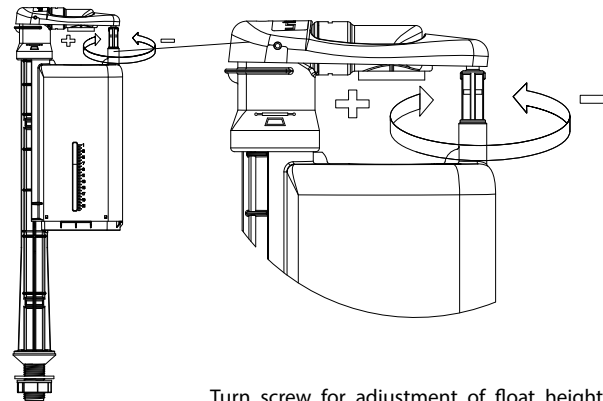

FLUSH VALVE ADJUSTMENT

The flush valve is factory set but if adjustment is required see diagram below.

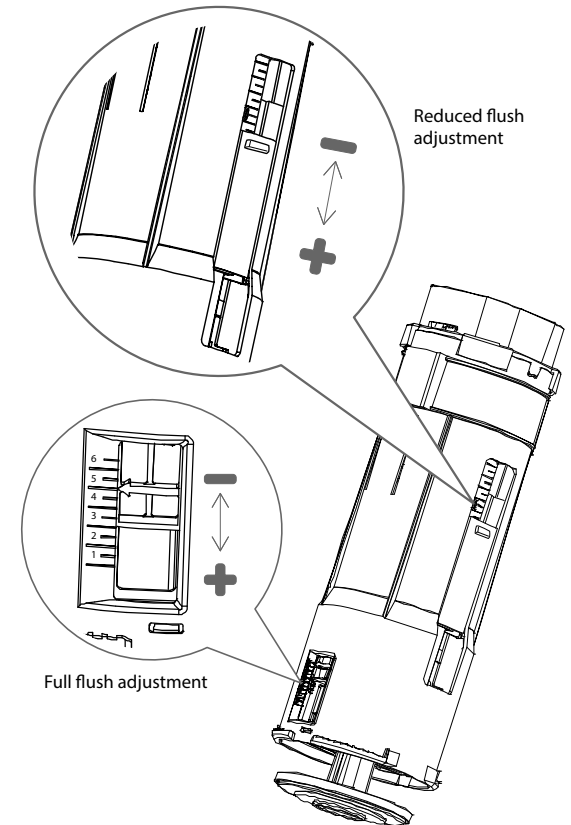

IMPORTANT

Flush out all impurities in the cistern prior to installation.

Cistern fittings are suitable for Water pressure: 0.2 - 8 bar

CLOSE COUPLED WC

FITTING INSTRUCTIONS

This product must be installed by a qualified fitter or plumber in accordance with and meet the requirements of Water Supply (Water Fittings) Regulations 1999, the Water Supply (Water Fittings) (Scotland) Byelaws 2014 and the Water Supply (Water Fittings) Regulations (Northern Ireland) 2009

FITTING THE CISTERN TO THE TOILET PAN

With the flush valve and inlet valve fitted and adjusted the cistern tank can be fitted to the pan.

Fit the gasket around the flush valve outlet on the underside of the cistern.

When fitting the cistern to the pan take care to ensure the gasket is properly aligned in the gasket location. Failing to do so could result in leakage.

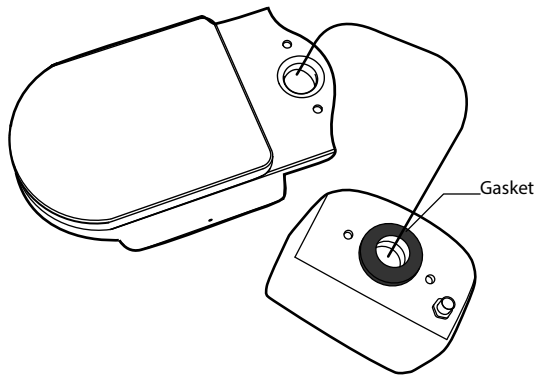

Insert the cistern fitting bolts arranging the components as shown in the diagram below.

Firmly tighten the nuts and wing nuts taking care not to overtighten as this could damage the ceramic.

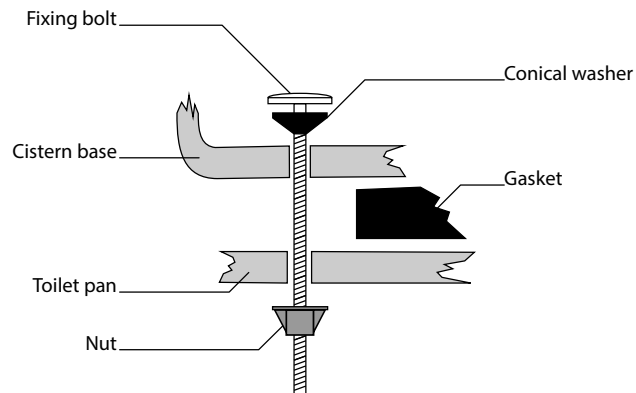

INSTALLING PUSH BUTTON

Fit the push button to the cistern lid using the plastic fixing nut.

Ensure the pins make contact with the flush buttons on the flush valve. To adjust the length of the rods turn the nut clockwise and anti-clockwise.

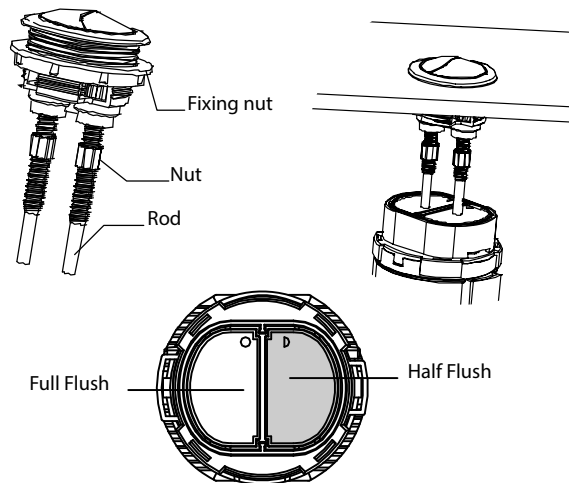

MAKING PLUMBING CONNECTIONS

Connect a NEW WC Pan waste connector and ensure it is adequately sealed around the toilet pan outlet to prevent leakage.

The inlet valve has a threaded connector. It is recommended that this thread is wrapped in PTFE tape before connecting the water supply. Do not overtighten the supply to the inlet valve as this could damage the inlet valve causing leakage.

Do NOT use silicone around gaskets or rubber seals as this will impair sealing of the rubber components. After connecting the water supply to the inlet valve check that the inlet valve components do not touch the internal walls of the cistern and the float can move freely up and down.

Check all connections are secure and a soil pipe is fitted before testing the flush.

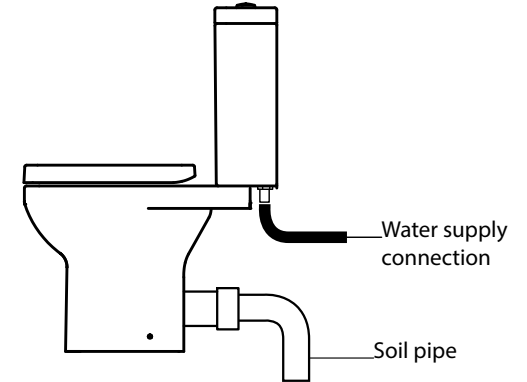

CONNECTION TO WATER SUPPLY

Connect the water supply to the cistern using an approved double check valve to fluid category 3 in addition to an accessible service valve.

OPERATION

Press the large button once for a large flush (6 litres factory setting)
Press the small button once for a small flush (4 litres factory setting)

CARE

DO NOT introduce caustic chemical substances (e.g. containing chlorine compounds or similar). These can damage the valve components and cause failure.

AIR GAP & WATER LEVEL

It is important that there is a minimum air gap between the outlet of the fill valve and the top of the overflow of 30mm.

Also, the water level in the tank must be between 25-32mm below overflow tube on the flush valve.

SLIM D SHAPE

Soft Close Quick Release
Wrapover PP Toilet Seat

FITTING INSTRUCTIONS

Please read carefully before attempting to fit the seat & refer to the 'does it fit' diagram below to ensure it's suitable for your toilet.
Please make sure the warnings and after-care instructions are made available for the end user to read.

Does it fit?

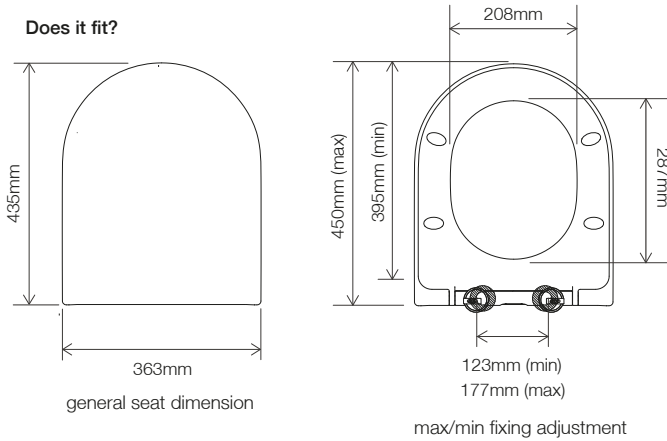

Installation Parts

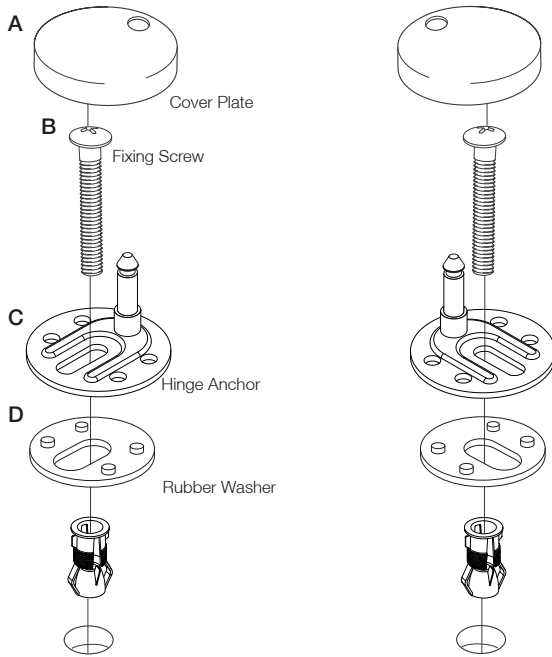

1 Push top fix inserts into toilet pan holes

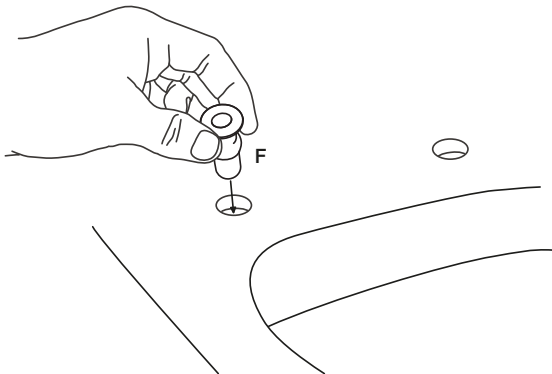

If difficult to push in, lubricate the rubber insert with water.

2 Insert the screw through the anchor and tighten up with a screwdriver until the anchor is loosely secured to allow for further adjustment.

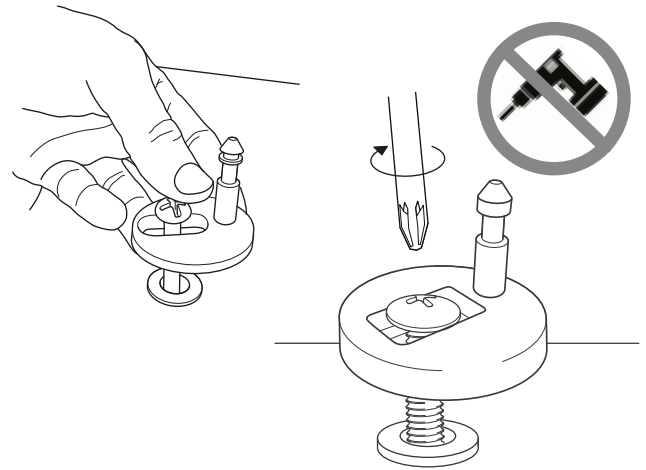

3 Click the seat on

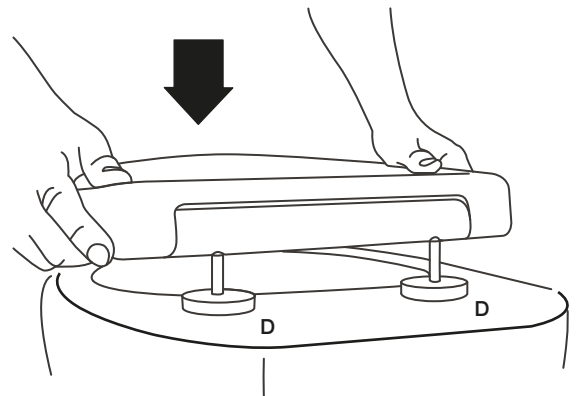

4 Adjust seat to correct position

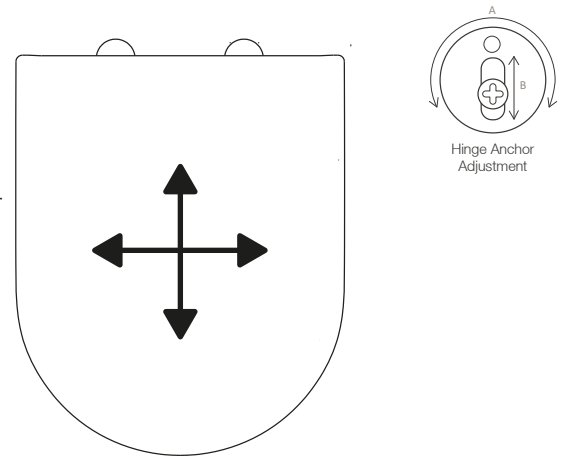

Adjust the position of the hinge anchors to make sure the seat lines up with the edges of the toilet pan.

5 Press the quick release button and remove the toilet seat

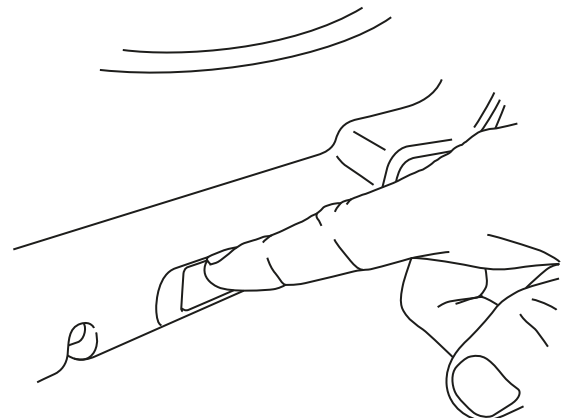

6 Fully tighten hinge anchors

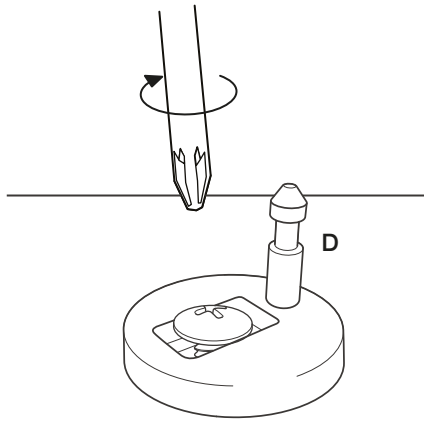

Secure as tightly as possible by hand. Do NOT use a battery drill or driver.

7 Place on cover caps and click seat into place.

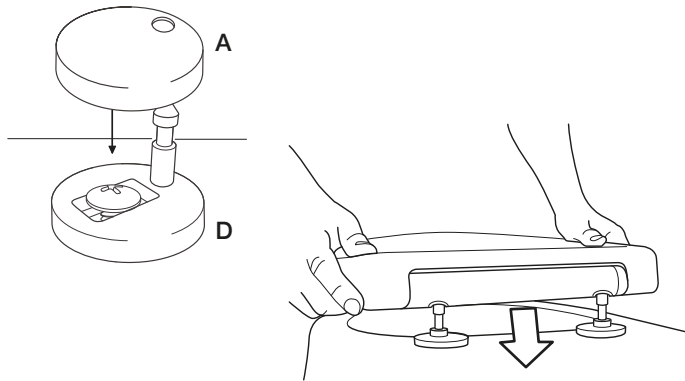

WARNINGS

- The fittings pack contains small items which should be kept away from young children.
- The toilet seat can be dangerous if incorrectly installed. Assembly should be carried out by a competent person. No liability will be accepted for damage or injury caused by incorrect product installation or assembly.
- Do not stand on the lid or ring of your toilet seat.
- After a few days check that the fixings are still tight. This is necessary as the rubber components will compress during the first few days.
- Periodically check all fixings to ensure none have come loose and re-tighten where necessary. Please take care when handling or moving the toilet seat as careless handling may cause damage or injury.
- Never over rotate the seat open when it is removed from the WC as this can cause damage to the hinges.
- Do not force down the seat ring or lid as this may compromise the performance of the soft close hinges.

AFTERCARE INSTRUCTIONS

Removing seat for cleaning

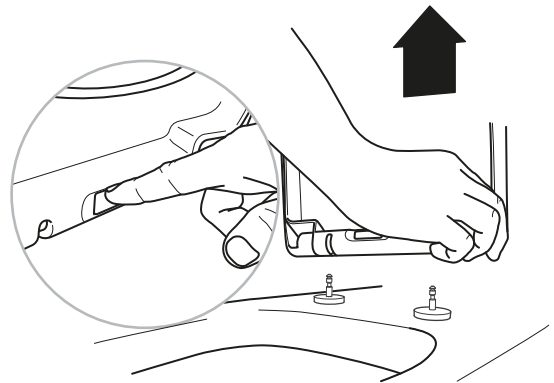

Clean surfaces with a soft damp cloth and mild soap solution



Do not scrub or scour



Do not use abrasive cleaning agents. If using bleach, abrasive or corrosive cleaning agents inside the toilet bowl, ensure that these do not come into contact with the seat. Keep the seat in the upright position until all cleaner has been flushed away.



Do not stand on the lid or ring of your toilet seat

For Technical Help Call:
01225 303 900

Customer Services | Brassmill Lane Trading Estate | Bath | BA1 3JF