

Genuine Accessories



Vehicle Model: **Palisade**

Model Year 2020~
 Part No. S8F21 AU001
 Language English
 Rev. Date 12/16/2022

Accessory: **Crossbars**

Difficulty: (A)

Note: Difficulty stated above reflects the minimum level of expertise required to install the accessory.

- (A) Customer
- (B) Dealer Technician
- (C) Master Technician or Specialist

Electronic Installation Instructions











If this is a printed copy of the installation instructions, ensure you have the latest revision by scanning the QR code or by entering the website address listed below before beginning installation. Use the latest revision date as noted by "Rev. Date" above.

www.hyundaiaccessories.com/admin_media_uploads/installationSheets/s8f21_au001.pdf

NOTICE: Improperly installed Crossbars may increase windnoise in the vehicle cabin. To avoid, ensure that the Crossbars are installed in the correct position, per this instruction.

Instructional Symbols / Definitions

 Denotes warnings that may lead to serious physical injury or vehicle damage	 Denotes quality processes to be checked prior to moving to the next step	Denotes personal protective equipment (PPEs) that may be required for a step. Examples of safety equipment icons noted below:
 Denotes cautions to be taken to avoid physical injury or electronic component damage	 Denotes specific tools that are necessary to complete a step	 Glasses
 Denotes cautions to be taken to avoid vehicle and component damage	<p style="text-align: center; border: 1px solid black; padding: 2px;">N O T E</p> Denotes important information to be reviewed during the step	 Gloves
		 Mask
		 Hearing Protection

Basic Required Tools

 Clean Cloth	 Step Ladder	 Tape Measure
--------------------------------------------------------------------------------------------------	--------------------------------------------------------------------------------------------------	---------------------------------------------------------------------------------------------------





Part Weight (Gross)

10.65	lbs
4.83	kg

FMVSS 110 Compliance Information

All dealers must determine if the Net weight they have added in the form of all options or accessories, when added to the weight of all Port/Dealer Installed options or accessories, exceeds the lesser of 1.5% of GVWR or 100 lbs. If the additional weight does exceed the lesser of the indicated thresholds, a "Load Carrying Capacity Reduced" label must be installed. A black, fine-point, indelible marker must be used to write by hand onto the label, the reduced carrying capacity in kilograms or pounds, which is the total weight of all added options and accessories.
Load Label Part Number: NP070 - 09003

REGULARLY CHECK THE TIGHTNESS BY PERFORMING A TUG ON CROSSBARS. THEY SHOULD NOT MOVE. If crossbars move, see step 3-5 for proper tightening. Incorrect clamp tightness can cause crossbar separation from vehicle resulting in product failure and vehicle damage. Serious physical injury may occur.

-  Loads must be evenly distributed and secured. Failure to adhere to distribution requirements may result in loss of vehicle control, severe personal injury, or death.
-  Any weight carried on the vehicle will adversely affect its handling particularly in cornering or in a cross wind and the vehicle should therefore be driven with increased caution.
-  Only use NON-STRETCH tie down straps. Use of stretch elastic tie downs may cause loss of load, potential serious injury, and vehicle damage.
-  **Never exceed crossbars load limit of 220 LBS / 100 KG.** Failure to adhere to load limits may result in loss of vehicle control, severe personal injury, or death.

Notes to the installer:

- 1) Read the entire Installation Instructions prior to beginning the installation of this accessory.
- 2) If applicable, scan the barcode label located on the accessory part or packaging prior to installing, to register the part. If this accessory is installed as a replacement, register the removal of the old part before registering the new part. Old and new parts will have different barcode data, and the old registration cannot be reused.
- 3) Make sure the vehicle is completely clean and dry in the area(s) the part is to be installed.
- 4) Ensure the vehicle is properly protected in the area(s) that the accessory is to be installed.
- 5) NEVER place tools on painted surfaces, seating surfaces, dash pad, console or floor carpet/mats.
- 6) Always wear appropriate personal protective equipment, including gloves, safety glasses, etc., when required.

Genuine Accessories

Kit Overview

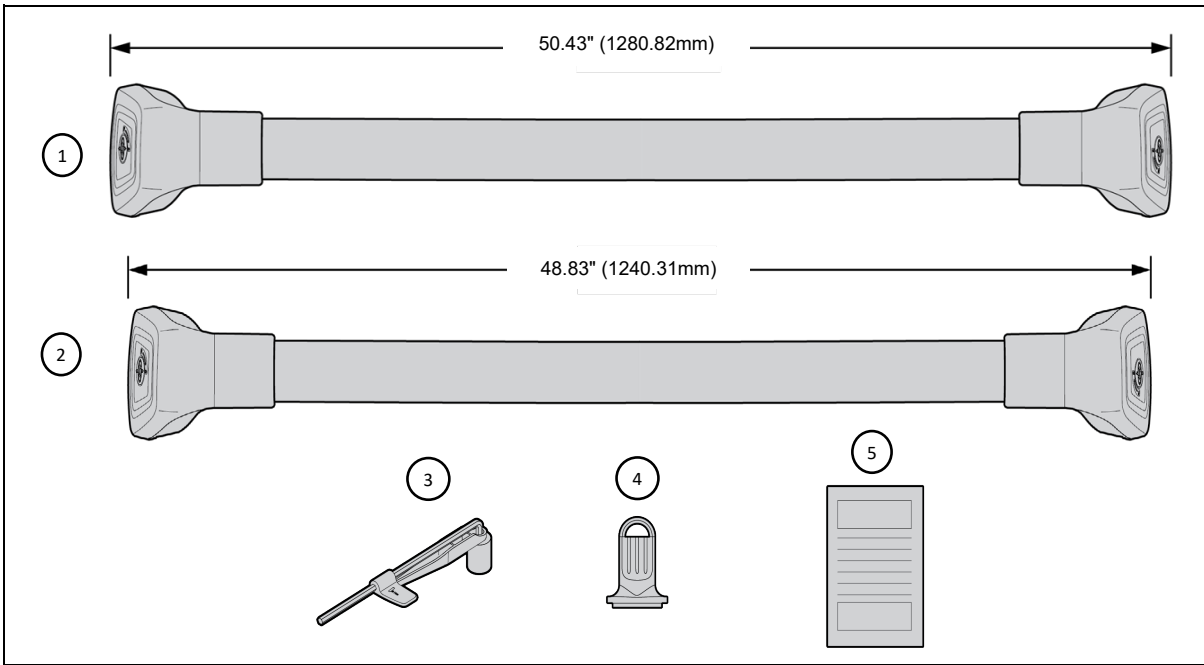

No.	Qty	Description
1	1	Front Crossbar (Longer - 50.43" (1280.82mm))
2	1	Rear Crossbar (Shorter - 48.83" (1240.31mm))
3	1	Wrench
4	1	Cover Key
5	1	Quick Reference Guide

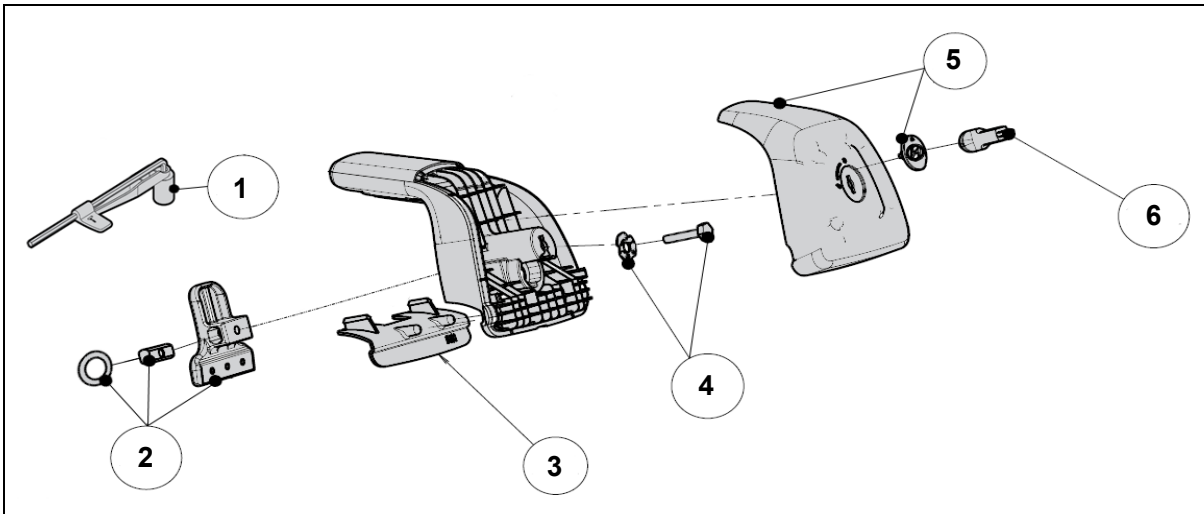

Service Part Overview





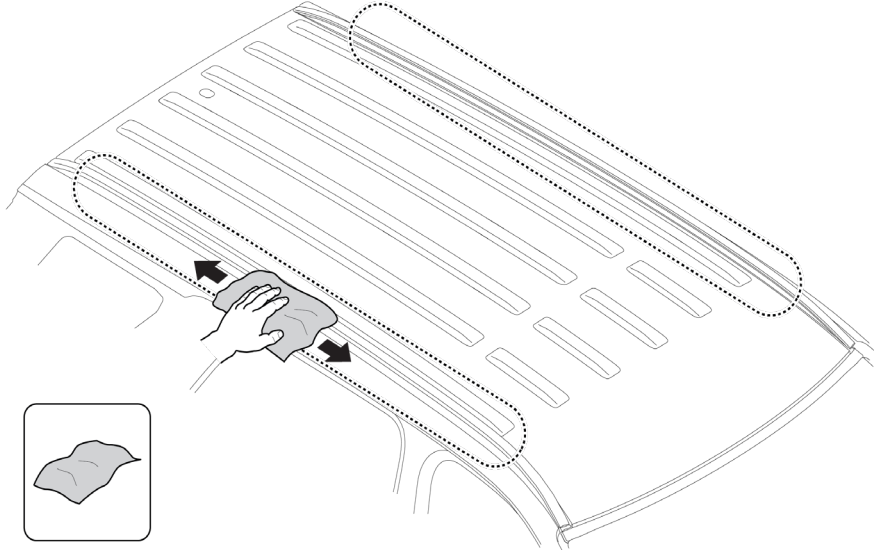

No.	Qty	Service Part Number	Description
1	1	S8F21 AU010	Torque Tool (Wrench)
2	1	S8F21 AU070	Ass'y Clamp - RH
2	1	S8F21 AU080	Ass'y Clamp - LH
3	1	S8F21 AU050	Pad Set - Support (RH & LH)

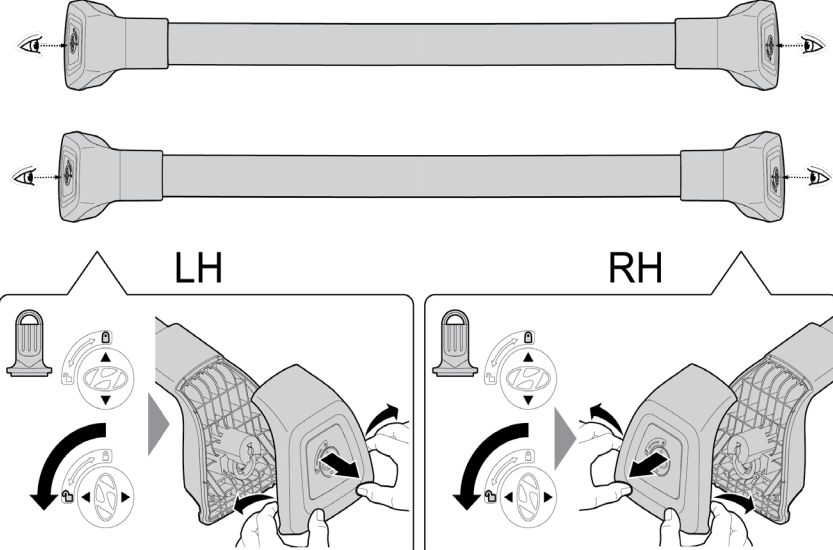
No.	Qty	Service Part Number	Description
4	4	S8F21 AU020	Fastener Set
5	1	S8F21 AU030	Cover Assy - RH
5	1	S8F21 AU040	Cover Assy - LH
6	1	S8F21 AU060	Lever Lock Key (Cover Key)

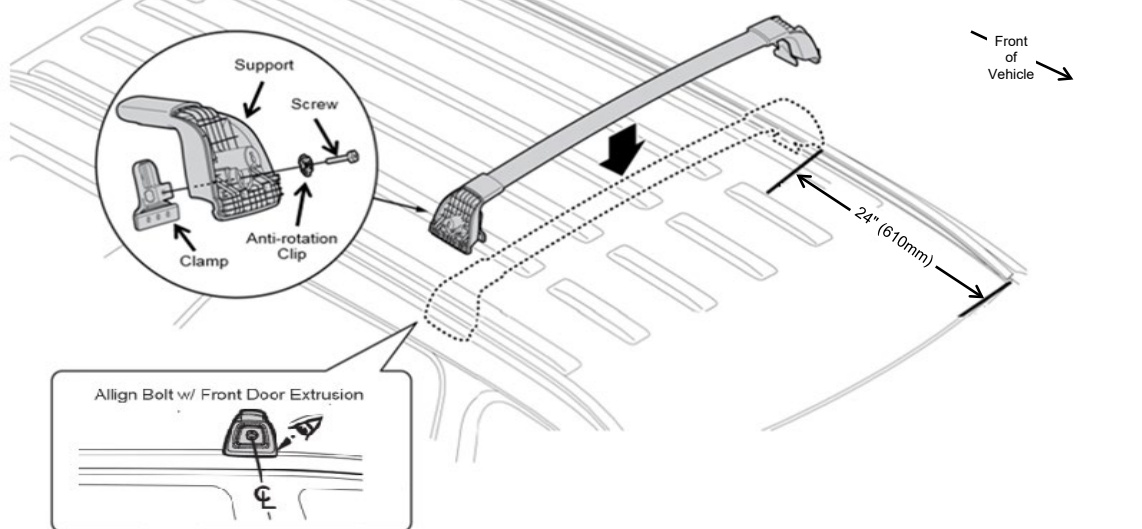

Genuine Accessories

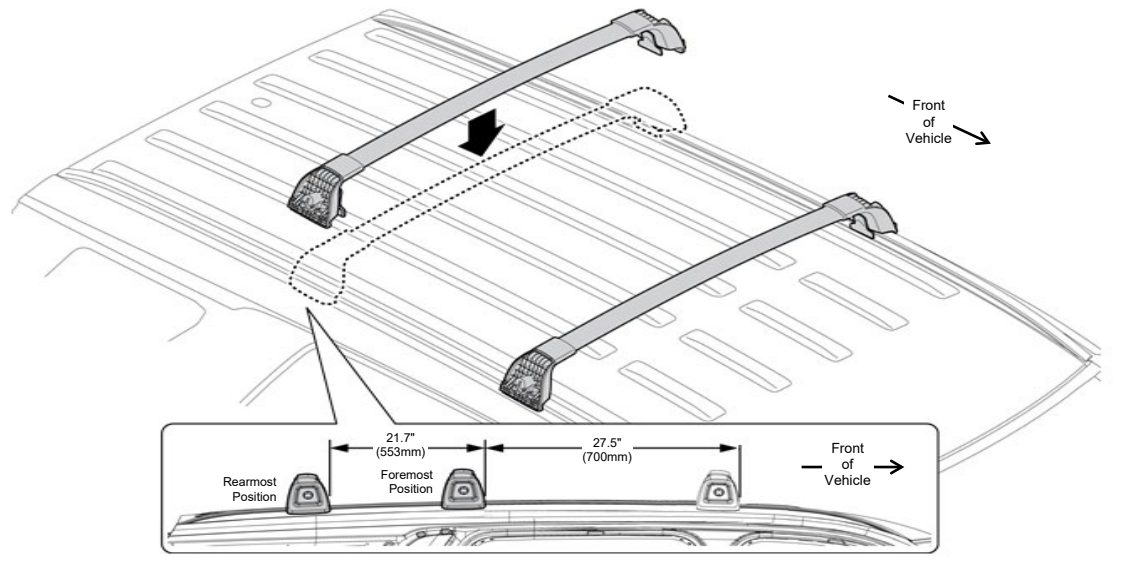

1		Step Ladder and Clean Cloth
		
NOTE	A. Clean the side roof rails in the areas shown.	
	Do NOT scratch or damage the vehicle.	
2		Cover Key
		
NOTE	A. Using the supplied cover key, unlock and remove all four (4) crossbar covers. B. Set the four (4) covers aside in a safe location.	

Genuine Accessories

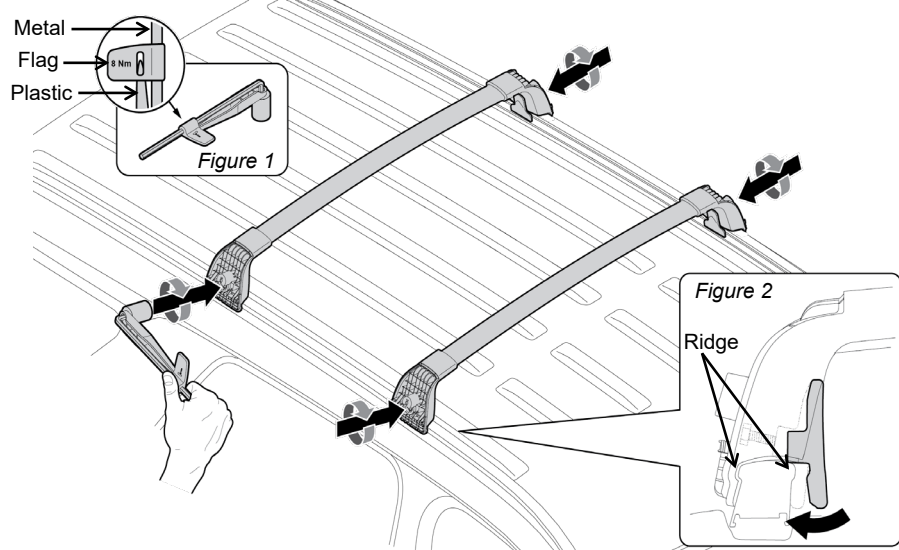

3		<p>Step Ladder, Wrench and Tape Measure</p> 
<p style="writing-mode: vertical-rl; transform: rotate(180deg);">NOTE</p>		<p>A. Locate the front crossbar (longer crossbar). B. Verify "RH" and "LH" markings inside the clamp housings for proper orientation. C. Loosen the clamp housing bolts by turning six (6) full rotations in counterclockwise direction using the supplied wrench, but DO NOT take bolts out completely. NOTE: If the clamp is loosened completely, start initial thread engagement by hand first and then use supplied wrench. (See above for order of assembly) D. Carefully place the front crossbar onto the roof side rails. E. Position the forward edge of the front crossbar 24" (610mm) from the forwardmost edge of the roof side rail on both sides of the vehicle. CAUTION: The front crossbar should only be positioned 24" (610mm) from the leading edge of the side rails to prevent potentially damaging the sunroof.</p>
		<p>CAUTION: Improper placement of the front crossbar may interfere or damage vehicle's sunroof. Do NOT scratch or damage the vehicle.</p>
4		<p>Step Ladder, Wrench and Tape Measure</p> 
<p style="writing-mode: vertical-rl; transform: rotate(180deg);">NOTE</p>		<p>A. Locate the rear crossbar (shorter crossbar). B. Verify "RH" and "LH" markings inside the clamp housings for proper orientation. C. Loosen the clamp housing bolts by turning six (6) full rotations in counterclockwise direction using the supplied wrench, but DO NOT take bolts out completely. NOTE: If the clamp is loosened completely, start initial thread engagement by hand first and then use supplied wrench. D. Carefully place the rear crossbar onto the roof side rails. E. Position the forward edge of the rear crossbar 27.5" (700mm) from the forwardmost edge of the front crossbar on both sides of the vehicle. NOTE: The rear crossbar can be positioned further rearward if desired, but cannot be positioned less than 27.5" (700mm) from the front crossbar. (See above for positioning options)</p>
		<p>CAUTION: Improper placement of the crossbars may interfere or damage vehicle's sunroof. Do NOT scratch or damage the vehicle.</p>

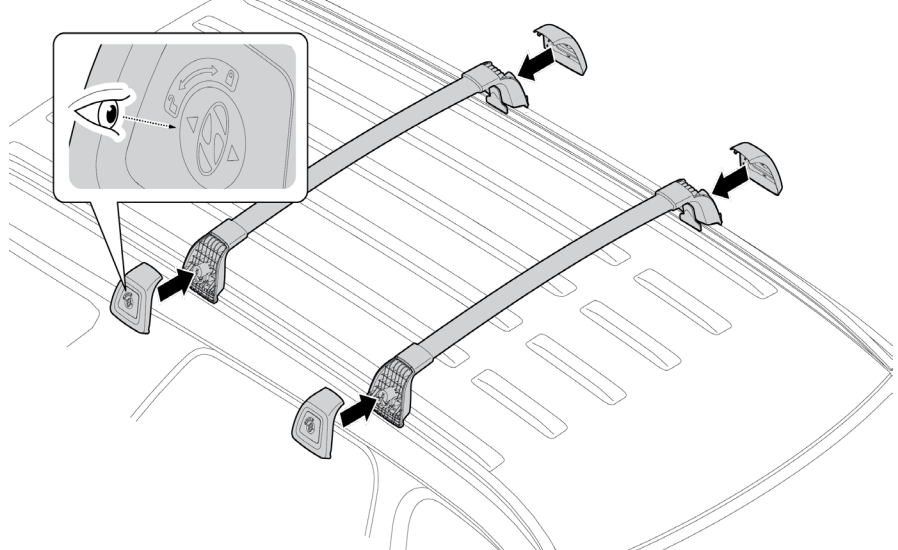

Genuine Accessories

5		Step Ladder and Wrench
		
<p style="margin: 0;">N O T E</p>	<p>A. Tighten all four (4) clamp housing bolts using the supplied wrench. NOTE: Only hold the metal portion of the wrench while tightening and apply inward pressure until the plastic needle is in the center of the flag window as shown in <i>Figure 1</i>. For Reference: Torque value is 70.80 lbf-in (81.58 kgf-cm, 8.00 N.m) B. Ensure all four (4) clamps are secured under the ridge on the roof side rail as shown in <i>Figure 2</i>. C. By hand, verify each crossbar that all four (4) clamp housings are tight onto the vehicle's roof side rails. No movement should occur.</p>	
	<p>Do NOT scratch or damage the vehicle.</p>	

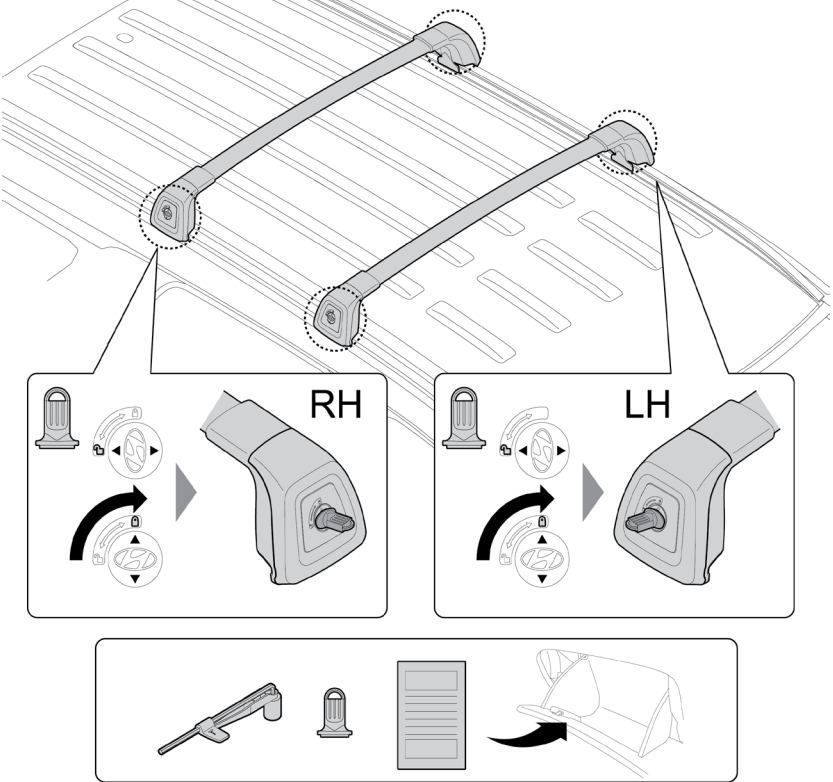
6		Step Ladder and Cover Key
		
<p style="margin: 0;">N O T E</p>	<p>A. Verify that all four (4) roof crossbar cover locks are in the unlocked position. B. Align tabs and apply pressure to assemble and fully seat all four (4) roof crossbar covers.</p>	
	<p>Ensure all four (4) covers are fully seated.</p>	

Genuine Accessories

7		Step Ladder and Cover Key
		
N O T E	<p>A. Using the supplied cover key, lock all four (4) crossbar covers as shown.</p> <p>B. Place the wrench, cover key and quick reference guide into the vehicle's glove box.</p> <p>NOTE: The covers need to be fully seated in position before locking.</p> <p>CAUTION: The covers will not remain engaged to the supports if not locked.</p> <p>CAUTION: Do not exceed 100 kg (220 lbs) evenly distributed on the crossbars.</p>	
	Always verify vehicle height with crossbars installed and load for parking lots and low height vehicle entry / exits.	

Visual Check		
Item to be Checked		Result
	Ensure all four (4) bolts are torqued properly with the supplied wrench.	All four (4) bolts are torqued properly.
	Ensure all four (4) crossbar covers are in the locked position.	All four (4) crossbar covers are locked.
	Ensure the crossbars are in a locked position and do not jiggle or rattle. Firmly grab crossbar and wiggle in forward / rearward and upward / downward motions. No movement should occur.	Crossbars are secure.