



INSTALLATION MANUAL

CLOUD GATEWAY

Please read this installation manual completely before installing the product.

Installation work must be performed in accordance with the national wiring standards by authorized personnel only. Please retain this installation manual for future reference after reading it thoroughly.

Cloud Gateway
PWFMDB200
Original instruction



MFL71720405
Rev.02_070124

www.lghvac.com
www.lg.com

Copyright © 2021 - 2024 LG Electronics Inc. All Rights Reserved.

ENGLISH

FRANÇAIS

ESPAÑOL

Important Safety Instructions

READ ALL INSTRUCTIONS BEFORE USING THE APPLIANCE.

Always comply with the following precautions to avoid dangerous situations and ensure peak performance of your product.

⚠ WARNING

It can result in serious injury or death when the directions are ignored.

⚠ CAUTION

It can result in minor injury or product damage when the directions are ignored.

⚠ WARNING

- Installation or repairs made by unqualified persons can result in hazards to you and others.
- Installation work must be performed in accordance with the National Electric Code by qualified and authorized personnel only.
- The information contained in the manual is intended for use by a qualified service technician familiar with safety procedures and equipped with the proper tools and test instruments.
- Failure to carefully read and follow all instructions in this manual can result in equipment malfunction, property damage, personal injury and/or death.

Installation

- When you re-install an already installed product, please contact the store of purchase or service center for the installation service. If a non-expert without authorization installs the product, it may cause fire, electric shock, or explosion and may cause injury of the user, and it may cause failure of the product.
- Do not twist or damage the power lines. It may cause a fire or electric shock.
- When performing an electric work, please contact the store of the purchase or service center. If a non-expert without authorization performs the disassembly or repair, it may cause fire or electric shock.
- Install the product in the place that can avoid rain. If water enters into the product, it may cause the product failure.
- Do not install the product in the place with a lot of moisture. If the moisture enters the product, it may cause the product failure.
- Make sure to contact the store of the purchase or service center for the product installation. If a non-expert without authorization installs the product, it may cause fire, electric shock, explosion or injury of the user, and it may cause failure of the product.

- Let an electricity installation specialist perform the electric work based on the installation manual and the designated circuit diagram. If an inappropriate wire is used or a non-expert performs the electric work, it may cause a fire or electric shock.
 - Do not place the product near a firearm. It may cause a fire.
 - When installing the product in the place such as hospital or communication station, etc., have sufficient protection facility for the noise. It may cause product failure or malfunction of other products.
 - Install the product solidly. If the product is loosely installed, the installed product may fall or it may cause product failure.
 - Correctly install the product after fully informed with the provided manual. It may cause a fire or electric shock.
 - During the wiring, do not use non-standard cable and do not extend by force to use. It may cause a fire or electric shock.
 - During the wiring of the power line and communication line, firmly fix the cable. If the cable is loosely installed, it may cause fire or electric shock.
 - Do not connect the power line to a communication terminal. It may cause a fire or electric shock or it may cause the product failure.
 - Do not install the product in the place with combustible gas leakage. It may cause a fire, electric shock, explosion, injury of the user, or product failure.
 - Install without tension on power cable. Tension on the power cords may cause the cords to break or a fire due to heating from the pressure.
 - Do not use when the power outlet that is damaged or loose. It may cause electric shock or product failure. ※ If it is a model using a plug.
 - Do not install the unit in potentially explosive atmospheres.
- In-use**
- Do not put a heavy object on the power lines. It may cause a fire or electric shock.
 - Do not arbitrarily change or extend the power lines. It may cause a fire or electric shock.
 - Use exclusive wire for the product. When using an unauthorized non-standard line, it may cause fire or electric shock.
 - Do not use a fire equipment near the power line. It may cause a fire or electric shock.
 - Be careful not to let water enter inside the product. It may cause electric shock or product failure.
 - Do not place a container with liquid on the product. It may cause product malfunction.

- Do not touch the product with wet hands. It may cause a fire or electric shock.
- Use the standard parts. If unauthorized parts are used, it may cause fire, electric shock, explosion, user injury, or product failure.
- When the product is flooded, make sure to contact the service center. It may cause a fire or electric shock.
- Do not impose shock on the product. Doing so will cause the product failure.
- Do not store or use combustible gas or ignition material near the product. It may cause a fire or product failure.
- Do not disassemble, repair, or modify the product without authorization. It may cause fire or electric shock.
- For the children or elderly, use the product under the supervision of guardian. The negligence may cause safety accident or product failure.
- Use the product under the supervision of the guardian so that a child may not hang on the product. It may cause product damage or the product may fall and cause injury of a child.
- Check the usage range of operation temperature stated in the manual and use within the range. If there is no usage range stated in the manual, use it within the range of 0~40 °C. If it is used in an environment exceeding the operation temperature range, it may seriously damage the product.
- Do not press the switch or button of the product with a sharp object. It may cause electric shock or product failure.
- During wiring, do not work while the power of the product is connected. It may cause a fire or electric shock.
- If there is an abnormal sound, smell, or smoke from the product, stop using the product. It may cause a fire or electric shock.
- Do not place a heavy object on the product. Doing so will cause the product failure.
- Do not spray water directly on the product or wipe the product with a wet towel, etc. It may cause a fire or electric shock.
- Do not use the product for special usage such as animal or plant, precision equipment, preservation of art pieces, etc. and do not use the product in the place unsuitable for the installation. It may cause property damage.
- Dispose the packing materials safely. If it is not disposed, the left alone packaging material may injure the user.
- When you pulling out the power plug, hold the head of the plug to pull out, and do not touch the power plug with wet

hands. It may cause fire or product deformation.

- Make sure to cut off the power of the device when cleaning or inspecting. It may cause fire or product deformation.

⚠ CAUTION

Installation

- Install the product firmly on a place that can support the weight of the product. The product may fall that causes a damage.
- Do not use the product in the place with grease, steam, or sulfuric acid gas. It may cause a product performance degradation or a product damage.
- Check the rated capacity of the power. It may

cause a fire or product failure.

- Please use the adaptor provided where necessary.
 - If non-standard adaptor is used, it may cause product failure.
- When transporting the product, be careful not to drop or break the product. It may cause the product failure or injury of the transporting person.
- When wiring, do not let dew, water, insect, etc. enter the joint part where the wire is extended. If a foreign object enters, it may cause electric shock or product failure.

In-use

- When cleaning the product, do not use strong detergent such as sol-

vent type, and wipe with a soft cloth. When strong detergent such as solvent type is used, it may cause a fire or product deformation.

- Do not press the touch panel with a pointy or sharp objects. It may cause an electric shock or product failure.
- Do not let the product in contact with a metal material. Doing so may cause product failure.
- When sterilizing or disinfecting, stop using the product. It may cause malfunction of the product.
- Do not touch the inner part of the product. Doing so may cause product failure.
- After a long period usage of the product,

make sure to inspect the product condition. When the product is used for a long period of time, the product status may become worse, and the user may be injured when using.

- Do not store the product near liquid such as vase or water jar, etc. Fire or electric shock may occur.
- When the product is not used for a long period of time, lower the main power switch. Otherwise, it may result in fire or malfunction.
- This appliance is not intended for use by persons (including children) with reduced physical, sensory or mental capabilities or lack of experience and knowledge,

unless they have been given supervision or instruction concerning use of the appliance by a person responsible for their safety.

- Children should be supervised to ensure that they do not play with the appliance.
- This appliance can be used by children aged from 8 years and above and persons with reduced physical, sensory or mental capabilities or lack of experience and knowledge if they have been given supervision or instruction concerning use of the appliance in a safe way and understand the hazards involved. Children shall not play with the appliance. Cleaning and user maintenance shall not

be made by children without supervision.

AN ARBITRATION PROVISION

By using this product, you agree that all disputes between you and LG arising out of or relating in any way to this product (including but not limited to warranty disputes) shall be resolved exclusively through binding arbitration on an individual basis.

The terms of the arbitration agreement (including details on the procedure for resolving disputes) is available at www.lg.com/us/arbitration (USA) or www.lg.com/ca_en/arbitration (Canada) and/or your owner's manual or warranty.

Product composition



Controller



Wall installation plate



Wall installation screw



Controlled fixing screw

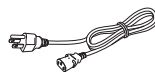

Power Cord

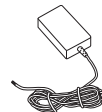

Power Adapter

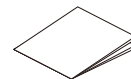

Installation / usage manual

NOTE :

Components or separately sold product may differ from the actual product picture.

Product specifications

Product specifications are as follows.

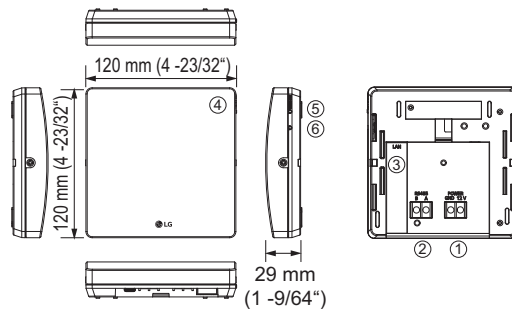

Number	Classification	Specifications	Other types
①	Power	10 V ~ 12 V \pm 15% (1.0 A)	Use of the output power of the Outdoor unit or other external source.
②	Communication	RS485	Maximum 1 km (3280')
③		Ethernet	10/100 Mbps
		Wi-Fi	2.4 GHz
④	LED	2ea	Left (Product mode, red) / Right (Power, green)
⑤	Switch	Change product mode	Registration (LED dimming) \leftrightarrow Use (LED lighting)
⑥		Reset the power	-
	Temperature Spec.	0 °C(32 °F) ~ 40 °C(104 °F)	Use Temperature
	Storage Temperature	-20 °C(-4 °F) ~ 60 °C(104 °F)	Storage Temperature

NOTE :

USB port (C-Type) is a function not used in the corresponding product.

Installation instruction

Installation and setting

This page describes the installation and setting methods to set up the controller.

To use the controller, an environment must be established in which the controller and the device (Air conditioner/ ventilation, etc.) can communicate with each other and the devices must be registered through the controller.

You need to install in the following order.

STEP 1. Installation environment inspection and equipment address setting

Before installing the controller, check the network configuration with the device interlocked to the power supply to the controller, and assign the connected device a nonoverlapping address.

STEP 2. Product installation

Install the controller and connect the power and communication lines.

STEP 3. Search indoor unit device

Search for the indoor unit device you want to use and save it to the product.

STEP 4. Install ThinQ app and register an account

See attached form 'Connecting LG ThinQ and LG Electronics'.

STEP 5. Connect and use ThinQ app

Interlocking with the ThinQ app to control/monitor the searched indoor unit.

⚠ CAUTION

Installation work requires specialized skills.

Therefore, the installation contents mentioned in this page must be carried out by a qualified installation technician.

* Refer to the latest technical information for BECON cloud interlocking and install.

If you have questions or requests related to the installation, please contact service center or installation specialty store acknowledged by LG.

Installation environment inspection and equipment address setting

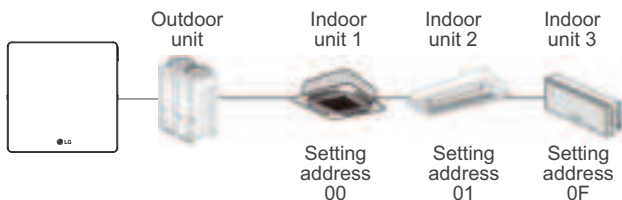

NOTE :

- The maximum allowable communication length guaranteed by LG Electronics is 1 km (3280'). In other words, the controller and the farthest installed device must be installed within the distance of 1 km (3280').
- It is recommended to use the communication cable which is more than 0.75 mm²(AWG18).
- Set the address that does not overlap within the same device type.
- When multiple different wireless LAN equipment are connected to the router to which you are connecting the controller, the wireless LAN malfunction may be caused (Such as delayed operation speed, disconnected, etc.) In this case, it is recommended to use a separate router to connect the controller.

Connection of RS485 communication line

One unit of controller can connect up to 16 indoor units.

When multiple devices are connected, they must be connected in a BUS format.

Otherwise, the controller may cause malfunction.

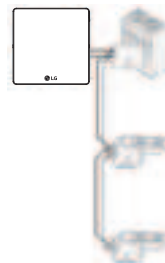

<Correct example : RS485 BUS format connection>

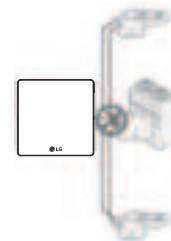

<Incorrect example : RS485 STAR format connection>

Indoor unit central control address setting

First, you need to grant address that does not overlap to each equipment (indoor unit, ventilation equipment) considering the entire installation composition connected to one controller.

The address of the device must be set within the range of 00~0F.

Note : Setting method of indoor unit central control address

The central control address setting method may be different according to the indoor unit product or remote controller type, so proceed the address setting by referring to the indoor unit product or wired remote controller manual.

Installation of the product and connection of RS485 communication line

Installing the product

Method for installing and cabling the controller is as follows.

1. Decide where to install the controller.

- Before fixing the controller to the wall, check if it is a suitable location to connect the controller, RS485 cable, power cable, and ethernet cable.

NOTE :

When installing turn off the power of the product connecting with the controller. Controller failure may occur when installing the controller with the connected product powered on.

2. Fix the wall installation plate of the controller on the wall.

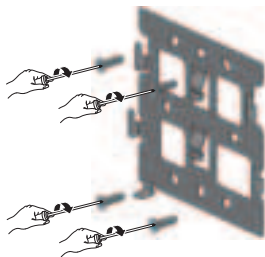

3. Connect RS485 cable located at the backside of the controller main unit to RS485 terminal.

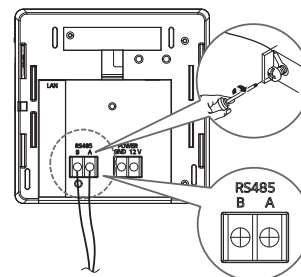

Remove the sheath using the guide as shown in the following figure during the T/B wiring, and then insert a short protecting sleeve into the O-ring or U-terminal to wiring.

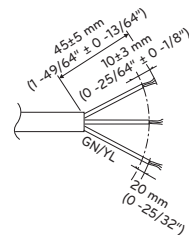

<Sheath removal guide>

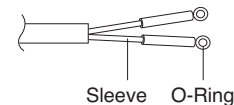

<Application appearance of O-Ring and sleeve>

⚠ CAUTION

Since RS485 communication cable connection has polarity, be careful not to reverse the connections of two lines.

When connecting the wire in reclamation structure, be careful of the bending of RS485 communication cable.

4. Connect the Ethernet cable to the LAN port on the back of the controller's main unit.

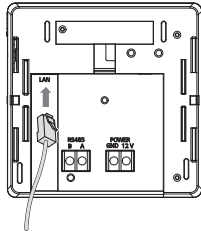

5. Connect the 12V \equiv power supplied through the outdoor unit to the power terminal located at the back of the controller's main unit.

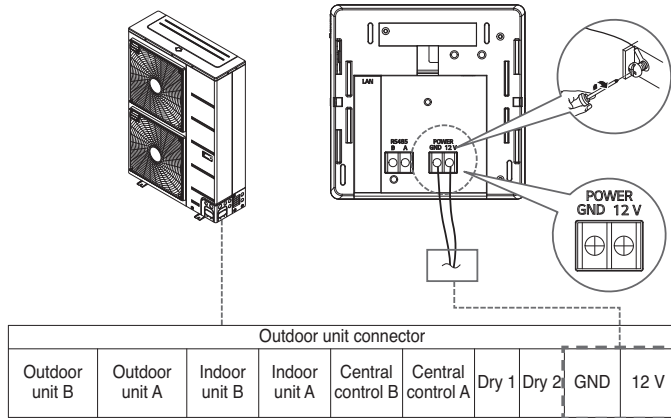

6. Match the groove of the product to the hook of the wall installation plate installed on the wall.

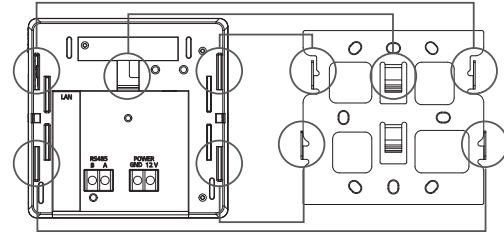

7. Lower the product to lock the hook. Fix the installation plate and product through the controller fixing screws after locking.

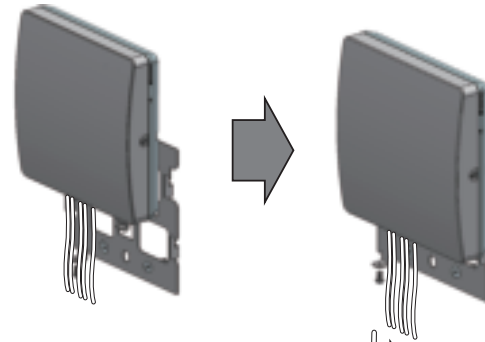

8. Turn on the power.



Search for the indoor unit device

Search for the indoor unit

Search for the installed indoor unit device and display the number of indoor units searched with LED.

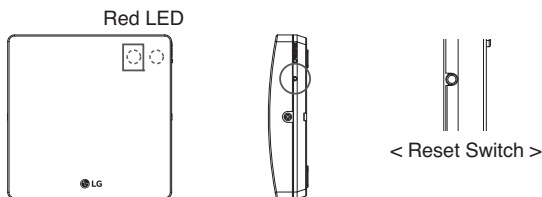

- 1) When the controller is powered on, the controller automatically initiates an indoor unit device search.
- 2) After 30 seconds, the indoor unit search is completed, and turns off after blinking LED as many as the number of indoor units found.
ex. 3 units of installation indoor unit → Turns off after blinking LED 3 times

NOTE :

Proceed with 'product registration' step after completing the search of the indoor unit device.

When the indoor unit search step is not completed and the next step is carried out, it will cause malfunction.

When the LED does not blink as much as the number of indoor unit connections, check the installation status of the indoor unit.

The reset switch allows to restart searching of indoor units by resetting the power.

Install the ThinQ app and register the account

Refer to the 'Connecting LG ThinQ and LG Electronics' manual attached in the page for the account registration method and ThinQ app installation.

Registering the product

- Check the product registration method according to the smart phone OS. Some screens may be different from the actual application screen.
- App image may vary depending on the ThinQ app version,
- When log in, press the product registration menu (+) on the main screen and select Cloud Gateway.

Connect the products to the network (Use wired)

- Verify that the Cloud Gateway is wired to the router.
- Press the register button on the side of the cloud gateway for at least 3 seconds.
- Please select the network to which the cloud gateway is connected in the smartphone's Wi-Fi settings.
- Click start search to display the connecting cloud gateway and select it to complete the network connection.

Connect the products to the network (Use wireless)

- Verify that the cloud gateway is wired to the router.
- Press the register button on the side of the cloud gateway for at least 3 seconds. The product's front LED blinks to verify that Wi-Fi connection is ready.
- Select the network to connect the cloud gateway to from the list of networks displayed in the app.
- Enter the password for the selected network (Router) and click Connect to complete the network connection.

Connecting LG ThinQ and LG Electronics

When you install the LG ThinQ app, you can conveniently manage your LG home appliance anytime, anywhere.

Applies to only models with Wi-Fi function.

1. Turn off the data function of the smartphone
 - Android phone users should turn off the mobile data.
 - iOS phone users should turn off the cellular data.

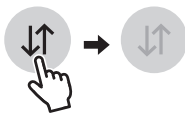

2. Connect the smartphone to the home Wi-Fi.
 - Wi-Fi names with 5G characters should not be selected. Models fitted to home appliances do not support 5 GHz.



3. Search for 'LG ThinQ' app and install.
 - Android phone users should search for the 'LG ThinQ' app in Google Play Store and install.
 - iOS phone users should search 'LG ThinQ' app in the Apple App Store and install.



4. Run the LG ThinQ app installed in the background of smartphone.



5. Log in to the LG ThinQ app.
 - Log in with the existing account or create an LG account.



6. Click the product registration menu (+) and select Cloud Gateway
 - Follow the instructions in the LG ThinQ app to proceed with the product registration.



NOTE :

- The Wi-Fi name and password are on the wireless router. Wi-Fi should only select 2.4 GHz. The modem mounted on the home appliance does not support 5 GHz and cannot connect the home appliance to the wireless router.
- WPA2 is recommended for the type of authentication and encryption of the wireless router.
- Wireless network connection quality can be affected by the surrounding wireless environment. If a failure occurs, contact internet service provider.
- When you can't connect home appliance's modem to wireless router, use the following methods to solve.
 - When a firewall is set on the wireless router, proceed after registering or releasing exceptions.
 - When the Wi-Fi name is in Korean or special characters, set it as English or numeric, or combination of English and numeric characters. When the name contains Korean or special characters, you cannot connect.
- When the distance between the product and the wireless router is too far, the signal strength is weakened. A weak signal can take a lot of time or fail to register the product.
- When changing the wireless router, internet service provider, or password, delete the registered product in LG ThinQ and re-register it.
- The content of this manual may vary depending on the version of the LG ThinQ application and may change without notifying the user.



Synchronize product connection information

- It will check the number of air conditioners available to connect to the cloud gateway.
- By clicking next the app will send and receive information with the cloud gateway.
- The app sends and receives product information and registers product information on the server.
- Once the product information is registered on the server, you can check the registered cloud gateway and connected air conditioner information on the main page of the app.
- The status display LED (red) of the cloud gateway is lit and remains lit while the server is connected.

Add product and check setting

- Click on the cloud gateway on the main page to check the connected air conditioner information.
- Addition of air conditioner and cloud gateway settings can be checked/changed via the top right screen, addition of products and Cloud Gateway Settings menu.

Controlling Air Conditioner via ThinQ

Control/ monitoring functions

The air conditioner control and information can be monitored via ThinQ app.

Click Cloud Gateway on the main page to check the connected air conditioner information.

The controllable items and condition information can be checked by selecting the air conditioner that you want to check the control and details.

Refer to the [Instructions] of ThinQ app for air conditioner control/ monitoring functions and instructions via ThinQ app.

Depending on the air conditioner model, some functions may not work, and depending on the version of the ThinQ app, the image may vary.

Open Source Software Notice Information

To obtain the source code under GPL, LGPL, MPL, and other open source licenses that have the obligations to disclose source code, that is contained in this product, and to access all referred license terms, copyright notices and other relevant documents please visit <https://opensource.lge.com>.

LG Electronics will also provide open source code to you on CD-ROM for a charge covering the cost of performing such distribution (such as the cost of media, shipping, and handling) upon email request to opensource@lge.com.

This offer is valid to anyone in receipt of this information for a period of three years after our last shipment of this product.

Wireless Product Specifications

Frequency range	2412 MHz ~ 2462 MHz
Output Power(Max)	< 30 dBm

Things to Check before Reporting Problems

When there is a problem with the product

When there is a problem with the product, please check the following cases before requesting to the service center.

Symptom	OK	Actions
“Product registration failed or product failed” message is displayed during product registration procedure in ThinQ app.	<ul style="list-style-type: none"> * Check the router setting 1) 5GHz setting 2) Signal strength (Less than -60db) 3) Security method (OPEN, WEP) 4) Incorrect password entry 	Setting the IP router <ul style="list-style-type: none"> 1) 2.4 GHz setting 2) Wireless signal strength is at least more than -60db 3) Security method change : WPA 4) Password check (English, number, some special characters)
Disconnection frequently occurs when using.	<ul style="list-style-type: none"> 1) Check whether the red LED of the controller is lighted. 2) Check Wi-Fi signal strength 3) Internet communication inspection 	When the controller LED is off, there may be a problem with internet connection. <ul style="list-style-type: none"> 1) Try resetting the controller using the reset button. 2) Try resetting the power of the router. 3) When continuous connection is not available Check that the Smartphone has an internet connection through the router. When there is no connection, request a router and internet inspection.

FCC Notice

This equipment has been tested and found to comply with the limits for a Class B digital device, pursuant to Part 15 of the FCC Rules. These limits are designed to provide reasonable protection against harmful interference in a residential installation. This equipment generates, uses, and can radiate radio frequency energy and, if not installed and used in accordance with the instructions, may cause harmful interference to radio communications. However, there is no guarantee that interference will not occur in a particular installation. If this equipment does cause harmful interference to radio or television reception, which can be determined by turning the equipment off and on, the user is encouraged to try to correct the interference by one or more of the following measures:

- Reorient or relocate the receiving antenna.
- Increase the separation between the equipment and the receiver.
- Connect the equipment to an outlet on a circuit different from that to which the receiver is connected.
- Consult the dealer or an experienced radio/TV technician for help.

This device complies with part 15 of the FCC Rules. Operation is subject to the following two conditions:

- (1) This device may not cause harmful interference and
- (2) This device must accept any interference received, including interference that may cause undesired operation of the device.

Any changes or modifications in construction of this device which are not expressly approved by the party responsible for compliance could void the user's authority to operate the equipment.

FCC RF Radiation Exposure Statement

This equipment complies with FCC radiation exposure limits set forth for an uncontrolled environment. This transmitter must not be co-located or operating in conjunction with any other antenna or transmitter.

This equipment should be installed and operated with a minimum distance of 20 cm (7.8 inches) between the antenna and your body. Users must follow the specific operating instructions for satisfying RF exposure compliance.

Industry Canada Statement

This device contains licence-exempt transmitter(s)/receiver(s) that comply with Innovation, Science and Economic Development Canada's licence-exempt RSS(s). Operation is subject to the following two conditions:

- (1) This device may not cause interference.
- (2) This device must accept any interference, including interference that may cause undesired operation of the device.

IC Radiation Exposure Statement

This equipment complies with IC radiation exposure limits set forth for an uncontrolled environment. This equipment should be installed and operated with a minimum distance of 20 cm (7.8 inches) between the antenna and your body.

NOTE: THE MANUFACTURER IS NOT RESPONSIBLE FOR ANY RADIO OR TV INTERFERENCE CAUSED BY UNAUTHORIZED MODIFICATIONS TO THIS EQUIPMENT. SUCH MODIFICATIONS COULD VOID THE USER'S AUTHORITY TO OPERATE THE EQUIPMENT.

⚠ WARNING

- **INGESTION HAZARD:** This product contains a button cell or coin battery.
* The icon 1) means the above warning text.
- **DEATH** or serious injury can occur if ingested. A swallowed button cell or coin battery can cause **Internal Chemical Burns** in as little as **2 hours**.
- **KEEP** new and used batteries **OUT OF REACH OF CHILDREN**.
- **Seek immediate medical attention** if a battery is suspected to be swallowed or inserted inside any part of the body.



LIMITED WARRANTY (USA)

The product's full Limited Warranty terms and conditions and arbitration requirements are available at <https://www.lghvac.com>

The product contains non-replaceable batteries.

- a) Remove and immediately recycle or dispose of used batteries according to local regulations and keep away from children. Do NOT dispose of batteries in household trash or incinerate.
- b) Even used batteries may cause severe injury or death.
- c) Call a local poison control center for treatment information.
- d) Compatible battery type is MS621FE.
- e) Nominal battery voltage is 3.3 V.
- f) Non-rechargeable batteries are not to be recharged.
- g) Do not force discharge, recharge, disassemble, heat above 104 °F or incinerate. Doing so may result in injury due to venting, leakage or explosion resulting in chemical burns.

WARRANTY (CANADA)

ARBITRATION NOTICE: THIS LIMITED WARRANTY CONTAINS AN ARBITRATION PROVISION THAT REQUIRES YOU AND LG TO RESOLVE DISPUTES BY BINDING ARBITRATION INSTEAD OF IN COURT, UNLESS THE LAWS OF YOUR PROVINCE OR TERRITORY DO NOT PERMIT THAT, OR, IN OTHER JURISDICTIONS, IF YOU CHOOSE TO OPT OUT. IN ARBITRATION, CLASS ACTIONS AND JURY TRIALS ARE NOT PERMITTED. PLEASE SEE THE SECTION TITLED "PROCEDURE FOR RESOLVING DISPUTES" BELOW.

PROCEDURE FOR RESOLVING DISPUTES(FOR CANADIAN PRODUCTS):

EXCEPT WHERE PROHIBITED AT LAW, ALL DISPUTES BETWEEN YOU AND LG ARISING OUT OF OR RELATING IN ANY WAY TO THIS LIMITED WARRANTY OR THE PRODUCT SHALL BE RESOLVED EXCLUSIVELY THROUGH BINDING ARBITRATION, AND NOT IN A COURT OF GENERAL JURISDICTION. EXCEPT WHERE PROHIBITED AT LAW, YOU AND LG BOTH IRREVOCABLY AGREE TO WAIVE THE RIGHT TO A JURY TRIAL AND TO BRING OR PARTICIPATE IN A CLASS ACTION.

Definitions. For the purposes of this section, references to "LG" mean LG Electronics Canada, Inc., its parents, subsidiaries and affiliates, and each of their officers, directors, employees, agents, beneficiaries, predecessors in interest, successors, assigns and suppliers; references to "dispute" or "claim" shall include any dispute, claim or controversy of any kind whatsoever (whether based in contract, tort, statute, regulation, ordinance, fraud, misrepresentation or any other legal or equitable theory) arising out of or relating in any way to the sale, condition or performance of the product or this Limited Warranty.

Notice of Dispute. In the event you intend to commence an arbitration proceeding, you must first notify LG in writing at least 30 days in advance of initiating the arbitration by sending a letter to LGECL Legal Team at 20 Norelco Drive, North York, Ontario, Canada M9L 2X6 (the "Notice of Dispute"). You and LG agree to engage in good faith discussions in an attempt to amicably resolve your claim. The notice must provide your name, address, and telephone number; identify the product that is the subject of the claim; and describe the nature of the claim and the relief being sought. If you and LG are unable to resolve the dispute within 30 days of LG's receipt of the Notice of Dispute, the dispute shall be resolved by binding arbitration in accordance with the procedure set out herein. You and LG both agree that, during the arbitration proceeding, the terms (including any amount) of any settlement offer made by either you or LG will not be disclosed to the arbitrator until the arbitrator determines the dispute.

Agreement to Binding Arbitration and Class Action Waiver. Upon failure to resolve the dispute during the 30 day period after LG's receipt of the Notice of Dispute, you and LG agree to resolve any claims between you and LG only by binding arbitration on an individual basis, unless you opt out as provided below, or you reside in a jurisdiction that prevents full application of this clause in the circumstances of the claims at issue (in which case if you are a consumer, this clause will only apply if you expressly agree to the arbitration). To the extent permitted by applicable law, any dispute between you and LG shall not be combined or consolidated with a dispute involving any other person's or entity's product or claim. More specifically, without limitation of the foregoing, except to the extent such a prohibition is not permitted at law, any dispute between you and LG shall not under any circumstances proceed as part of a class or representative action. Instead of arbitration, either party may bring an individual action in small claims court, but that small claims court action may not be brought on a class or representative basis except to the extent this prohibition is not permitted at law in your province or territory of jurisdiction as it relates to the claims at issue between you and LG.

Arbitration Rules and Procedures. To begin arbitration of a claim, either you or LG must make a written demand for arbitration. The arbitration will be private and confidential, and conducted on a simplified and expedited basis before a single arbitrator chosen by the parties under the provincial or territorial commercial arbitration law and rules of the province or territory of your residence. You must also send a copy of your written demand to LG at LG Electronics, Canada, Inc., Attn: Legal Department-Arbitration, 20 Norelco Drive, North York, Ontario M9L 2X6. This arbitration provision is governed by your applicable provincial or territorial commercial arbitration legislation. Judgment may be entered on the arbitrator's award in any court of competent jurisdiction. All issues are for the arbitrator to decide, except that, issues relating to the scope and enforceability of the arbitration provision and to the arbitrability of the dispute are for the court to decide. The arbitrator is bound by the terms of this provision.

Governing Law. The law of the province or territory of your purchase shall govern this Limited Warranty

and any disputes between you and LG except to the extent that such law is preempted by or inconsistent with applicable federal or provincial/territorial law. Should arbitration not be permitted for any claim, action, dispute or controversy between you and LG, you and LG agree to the exclusive jurisdiction of the courts of the province or territory of your purchase for the resolution of the claim, action, dispute or controversy between you and LG.

Fees/Costs. You do not need to pay any fee to begin an arbitration. Upon receipt of your written demand for arbitration, LG will promptly pay all arbitration filing fees unless you seek more than \$25,000 in damages, in which case the payment of these fees will be governed by the applicable arbitration rules. Except as otherwise provided for herein, LG will pay all filing, administration and arbitrator fees for any arbitration initiated in accordance with the applicable arbitration rules and this arbitration provision. If you prevail in the arbitration, LG will pay your attorneys' fees and expenses as long as they are reasonable, by considering factors including, but not limited to, the purchase amount and claim amount. Notwithstanding the foregoing, if applicable law allows for an award of reasonable attorneys' fees and expenses, an arbitrator can award them to the same extent that a court would. If the arbitrator finds either the substance of your claim or the relief sought in the demand is frivolous or brought for an improper purpose (as measured by the applicable laws), then the payment of all arbitration fees will be governed by the applicable arbitration rules. In such a situation, you agree to reimburse LG for all monies previously disbursed by it that are otherwise your obligation to pay under the applicable arbitration rules. Except as otherwise provided for, LG waives any rights it may have to seek attorneys' fees and expenses from you if LG prevails in the arbitration.

Hearings and Location. If your claim is for \$25,000 or less, you may choose to have the arbitration conducted solely (1) on the basis of documents submitted to the arbitrator, (2) through a telephonic hearing, or (3) by an in-person hearing as established by the applicable arbitration rules. If your claim exceeds \$25,000, the right to a hearing will be determined by the applicable arbitration rules. Any in-person arbitration hearings will be held at the nearest, most mutually-convenient arbitration location available within the province or territory in which you reside unless you and LG both agree to another location or agree to a telephonic arbitration.

Severability and Waiver. If any portion of this Limited Warranty (including these arbitration procedures) is unenforceable, the remaining provisions will continue in full force and effect to the maximum extent permitted by applicable law. Should LG fail to enforce strict performance of any provision of this Limited Warranty (including these arbitration procedures), it does not mean that LG intends to waive or has waived any provision or part of this Limited Warranty.

Opt Out. You may opt out of this dispute resolution procedure. If you opt out, neither you nor LG can require the other to participate in an arbitration proceeding. To opt out, you must send notice to LG no later than 30 calendar days from the date of the first consumer purchaser's purchase of the product by either (i) sending an e-mail to optout@lge.com, with the subject line: "Arbitration Opt Out"; or (ii) calling 1-800-980-2973. You must include in the opt out e-mail or provide by telephone: (a) your name and address; (b) the date on which the product was purchased; (c) the product model name or model number; and (d) the serial number (the serial number can be found (i) on the product; or (ii) online by accessing https://www.lg.com/ca_en/support/repair-service/schedule-repair and clicking on "Find My Model & Serial Number").

In the event that you "Opt Out", the law of the province or territory of your residence shall govern this Limited Warranty and any disputes between you and LG except to the extent that such law is preempted by or inconsistent with applicable federal or provincial/territorial law. Should arbitration not be permitted for any claim, action, dispute or controversy between you and LG, you and LG agree to the exclusive jurisdiction of the courts of the province or territory of your residence for the resolution of the claim, action, dispute or controversy between you and LG.

You may only opt out of the dispute resolution procedure in the manner described above (that is, by e-mail or telephone); no other form of notice will be effective to opt out of this dispute resolution procedure. Opting out of this dispute resolution procedure will not affect the coverage of the Limited Warranty in any way, and you will continue to enjoy the full benefits of the Limited Warranty. If you keep this product and do not opt out, then you accept all terms and conditions of the arbitration provision described above.

Conflict of Terms. In the event of a conflict or inconsistency between the terms of this Limited Warranty and the End User License Agreement ("EULA") in regards to dispute resolution, the terms of this Limited Warranty shall control and govern the rights and obligations of the parties and shall take precedence over the EULA.