

# Portable Jump Starter

**with Air Compressor (3000A 16,000mAh)**

CTJSPAC30PA

Safety & Warnings	3
Components	4
Overview	5
Operation	7
Specifications	11
Troubleshooting	12
Notes	15

# Safety & Warnings

## WARNING:

- Never use the jumper cables in an environment containing flammable gas.
  - Never allow the black and red clamps to come into contact, especially during the forced start phase. Doing so can result in serious accidents, including potential damage or injury.
- 
- Do not disassemble the jump starter under any circumstances.
  - If you notice swelling, leakage, or a strong odour from the jump starter, cease use immediately and contact [help.Kogan.com](https://www.kogan.com/help) for support.
  - Use the jump starter only in normal temperature conditions. Keep it away from humidity, open flames, or high-heat sources.
  - Allow a rest period of 30 seconds to 1 minute between consecutive vehicle starts.
  - Do not use the jump starter when its battery power is below 10%, as this may damage the device.
  - Fully charge the jump starter for at least 3 hours before its first use.
  - If the positive clamp is incorrectly connected to the negative pole of the car battery, the device includes protective features to prevent injury or property damage.
  - Ensure the jump starter is fully charged before its first use for optimal performance.
  - Always maintain at least 50% power in the jump starter during normal use.

# Components



Jump Starter with Air Compressor



Jumper Cables



Charging Cable

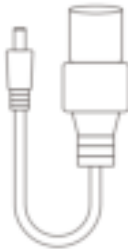

12V Outlet Converter



Valve Adapter (x4)

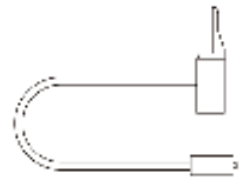

Air Hose



Carry Case



User Guide

# Overview

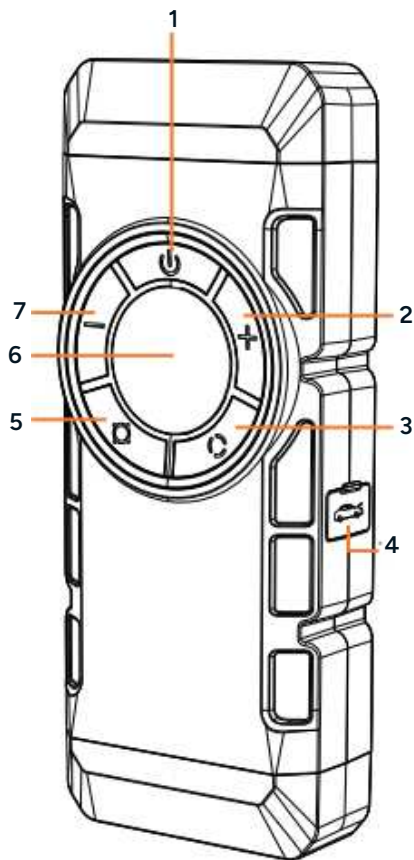

- 1 Power Button
- 2 Pressurise Button
- 3 Unit Button
- 4 Jump Start Port
- 5 Mode Button
- 6 Display Screen
- 7 Depressurise Button

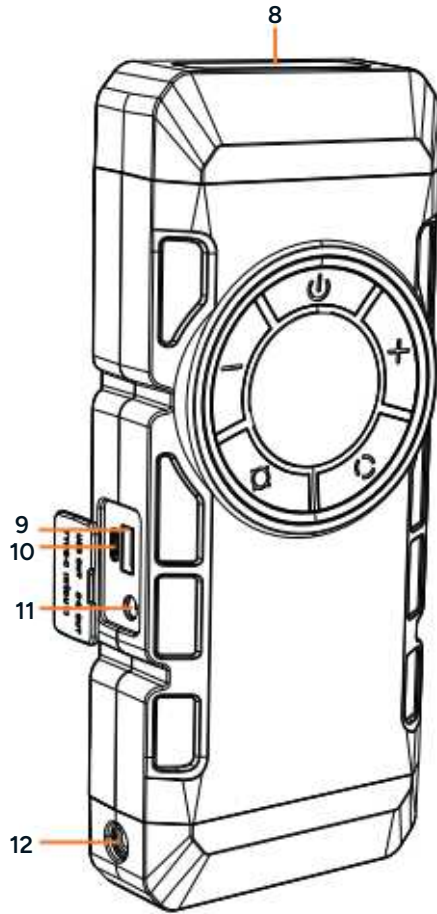

- 8 Light
- 9 USB Output Port
- 10 USB-C Input/Output Port
- 11 DC Output Port
- 12 Air Hose Port

# Operation

## Before Use

- Ensure the product is fully charged before its first use.
- Charge the product every 3 months, even if not in use, to prolong its lifespan.

## Charging the Jump Starter

1. Connect the USB-C end of the provided charging cable into the USB-C input port on the jump starter.
2. Connect the USB-A end of the cable into a USB-A power adapter.

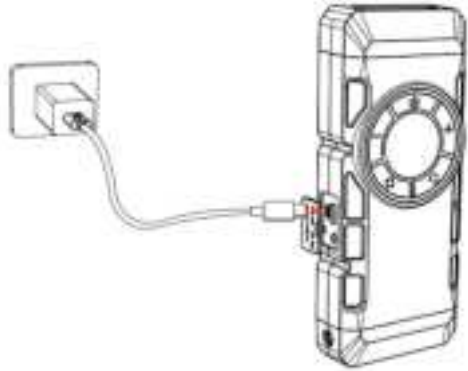





## Charging Other Devices

1. Use the provided charging cable, or a DC cable, to connect the jump starter to your smartphone, or other electronic device.
2. Press the 'Power' button to start charging. Disconnect the device once charging is complete.



## Button Functions

Icon	Button	Description
	Power Button	<ul style="list-style-type: none"><li>• Press to turn on the jump starter on/off.</li><li>• Press and hold to turn the flashlight on/off.</li><li>• In inflation mode, press to start inflation.</li></ul>
	Depressurise Button	Decreases the pressure value during inflation.
	Pressurise Button	Increases the pressure value during inflation.
	Mode Button	Switch to inflation mode.
	Unit Button	Switch between KPA, BAR, and PSI units in inflation mode.

## Flashlight

1. Press the 'Power' button to start the jump starter.
2. Press and hold the 'Power' button for 3 seconds to activate the white flashlight.
3. Continuously press the 'Power' button to cycle through flashlight modes (Strobe, SOS).
4. Press the 'Power' button again to turn off the flashlight.

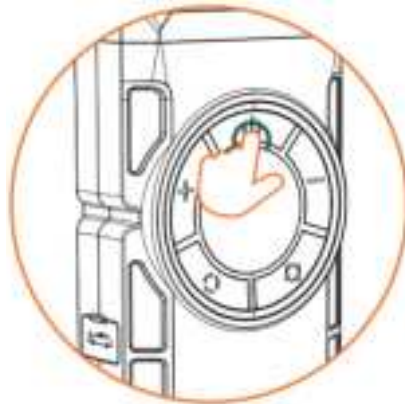



# Start a Vehicle

## Before You Begin:

- This product is compatible with 12V vehicles only.
- Ensure the product is sufficiently charged before starting your vehicle.

## Step 1:

Connect the jumper cable to the jump start port. When the indicator on the jumper cable turns blue, it is in standby mode.

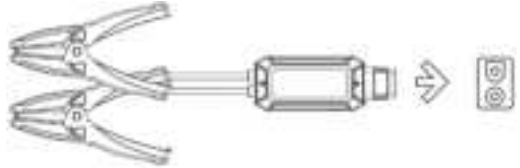

## Step 2:

- Attach the clamps to the car battery terminals:
  - Red clamp to the positive terminal (+).
  - Black clamp to the negative terminal (-).
- **Caution:** Ensure proper polarity to avoid damage.

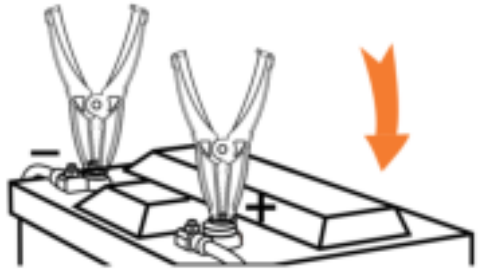

## Step 3:

When the jumper cable's indicator turns green, you can start the vehicle.



## Step 4:

After jump-starting the vehicle:

- Remove the clamps from the car battery terminals.
- Disconnect the jumper cables from the jump starter.



# Inflate Tires

## Step 1:

Connect the air hose securely to both the jump starter and the tire's air valve.

## Step 2:

Turn on the jump starter by briefly pressing the 'Power' button. Press the 'Mode' button to activate inflation mode.

- Default pressure unit: KPA (250).
- Use the 'Unit' button to switch to BAR (2.5) or PSI (36) as needed.
- Adjust the pressure value using the 'Pressurise' and 'Depressurise' buttons.



## Step 3:

Press and hold the 'Power' button to begin inflation. The display will show real-time tire pressure values.

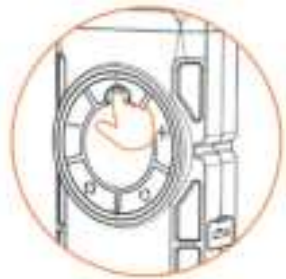

## Step 4:

- The jump starter will automatically stop once the pre-set pressure is reached.
- Allow the product to cool down after 10 minutes of continuous use to prevent overheating.

# Specifications

Peak Current	3000A
Start Voltage	12V
USB-C Input/Output	5V=3A, 9V=2A, 12V=1.5A
USB Output	5V=3A, 9V=2A, 12V=1.5A
DC Output	12~16. 8V=10A
Unit Display	KPA/BAR/PSI
Adjustable Pressure Range	1-1050KPA/0.1-10.5BAR/1-150PSI

# Troubleshooting

## Jumper Cable Indications

Status	Indicator	Description	Solution
Standby Mode	Blue	The jumper cables are connected to the jump starter.	N/A
Ready to Jump-Start	Green	The jumper clamps are correctly connected to the car battery.	N/A
Force Start Function	N/A	Use this if normal operations fail to start your car.	<ol style="list-style-type: none"><li>1. Ensure the jumper cable clamps are connected correctly.</li><li>2. Press and hold the 'Force Start' button on the jumper cables for 3 seconds until the indicator illuminates green.</li><li>3. Then, start the car within 30 seconds.</li></ol>

## Protection Features

Protection Type	Indicator	Description	Solution
Reverse Connection	RC (Red Light)	The clamps are connected to the wrong poles of the car battery.	Ensure the red clamp is connected to the positive pole and the black clamp to the negative pole.
High Temperature	HT (Red Light)	The jump starter emits a continuous alarm and voltage output is disabled when it overheats.	Wait until the jump starter cools down to resume operation.
Start Timeout	Blue Light	After $40 \pm 5$ seconds of inactivity, the jump starter automatically enters standby mode.	Disconnect the clamps and wait for 1 minute before retrying.
Low Capacity	LC (Red Light)	When the EC5 port detects power below $13.5V \pm 0.5V$ , the device emits a continuous alarm.	Recharge the jump starter.
Short Circuit Protection	N/A	No response occurs when the device detects a short circuit.	Ensure proper polarity and connect the jumper cables correctly to the car's engine poles.

## FAQ

Question	Answer
<p>What is the operating temperature of this jump starter, and how should it be stored?</p>	<ul style="list-style-type: none"> <li>• The recommended operating temperature is 0°C to 45°C.</li> <li>• Storing the jump starter in temperatures exceeding 45°C may cause the lithium-ion battery to expand, posing a safety risk.</li> <li>• Avoid leaving the product in a car for extended periods, especially during summer.</li> </ul>
<p>How long can the battery's storage capacity last?</p>	<ul style="list-style-type: none"> <li>• The battery storage capacity lasts approximately 4-6 months.</li> <li>• To maintain optimal performance, it is recommended to charge the jump starter every 2-3 months.</li> </ul>
<p>What should I do if the jump starter fails to charge?</p>	<ol style="list-style-type: none"> <li>1. Connect the jump starter to a 5V charger using a USB-C cable.</li> <li>2. Allow it to charge overnight.</li> <li>3. If the product still doesn't charge, contact <b>help.Kogan.com</b> for support.</li> </ol>
<p>Can this jump starter be used to start a 24V truck?</p>	<p>No, this jump starter is designed for 12V batteries only. It is not compatible with 24V trucks.</p>
<p>What should I do if the inflation is slow?</p>	<ol style="list-style-type: none"> <li>1. Check if the power source has sufficient charge.</li> <li>2. Inspect the air hose for leaks.</li> <li>3. Ensure the connection parts at both ends of the hose are securely tightened.</li> <li>4. Verify if the inflated object is leaking air.</li> </ol>
<p>What should I do if inflation does not occur?</p>	<ol style="list-style-type: none"> <li>1. Check if the device has sufficient power.</li> <li>2. Ensure the current tire pressure is not higher than the pre-set value.</li> </ol>
<p>What should I do if there is a leak in the air hose?</p>	<p>Tighten the air hose.</p>
<p>What should I do if the jump starter does not respond?</p>	<p>Restart the jump starter and try again.</p>

# Notes

---

---

---

---

---

---

---

---

---

---

---

---

---

---

---

---

---

---

---

---

---

---

---

---

---

---

---

---

---

---

### **Need more information?**

We hope that this user guide has given you the assistance needed for a simple set-up.

For the most up-to-date guide for your product, as well as any additional assistance you may require, head online to [help.kogan.com](https://help.kogan.com).

