

Water Level Monitoring Solution

USER MANUAL

Document Information	
Name	Water Level Monitoring Solution User Manual
Classification	Technical Documentation
Revision Information	
v01	12/12/2023

Table of Contents

1. Solution Overview.....	5
1.1. Description.....	5
1.2. Features.....	5
2. Hardware Introduction.....	6
2.1. Device List.....	6
2.2. Hardware Specifications.....	6
2.2.1. Sensor Hub Datasheet.....	6
2.2.2. Sensor Probe IO + Water Level Monitoring Sensor Datasheet.....	6
2.2.3. Solar Cell System Datasheet.....	7
2.2.3.a. Definition of Terms.....	7
2.2.3.b. Main Specifications.....	9
2.2.3.c. Interfaces.....	10
2.2.3.d. Electrical Characteristics.....	12
3. Prerequisites.....	17
3.1. Hardware.....	17
3.2. Software.....	17
4. Solution Configuration.....	17
4.1. Sensor Hub Setup.....	17
4.1.1. SIM Card Installation.....	17
4.1.2. Sensor Hub Mounting.....	18
4.1.2.a. Wall Mounting.....	18
4.1.2.b. Pole Mounting.....	20
4.2. RAK2560 WisNode Sensor Hub + Water Level Sensor Setup.....	22
4.2.1. Sensor Probe IO + Water Level Sensor Installation.....	22
4.2.2. Sensor Hub + Sensor Probe IO + Water Level Sensor Installation	23
4.3. Power Supply Setup.....	24
4.3.1. RAK9154 Solar Battery Installation.....	25
4.3.2. 12 VDC Power Supply Installation.....	28
5. Software Configuration Guide.....	29
5.1. Sensor Hub Configuration.....	29

- 5.1.1. Power Up Sensor Hub..... 29
- 5.1.2. Connect Sensor Hub to WisToolBox..... 30
- 5.1.3. Sensor Hub Network Configuration..... 38
 - 5.1.3.a. LoRaWAN Configuration..... 38
 - 5.1.3.b. NB-IoT/LTE CAT-M1 Configuration..... 42
- 5.1.4. Sensor Configuration..... 45
- 6. Network Server and Visualization Configuration..... 51
 - 6.1. LoRaWAN Application..... 51
 - 6.1.1. Cloud Network Server Setup..... 51
 - 6.1.1.a. Connect Gateway to TTN..... 52
 - 6.1.1.b. Connect Sensor Hub to TTN..... 57
 - 6.1.1.c. Visualize Data Through Datacake..... 60
 - 6.1.2. Built-In Network Server Setup..... 73
 - 6.1.2.a. Configure ThingsBoard..... 74
 - 6.1.2.b. Configure Gateway..... 82
 - 6.1.2.c. Connect Sensor Hub to Built-In Network Server..... 90
 - 6.1.2.d. Configure MQTT Integration..... 90
 - 6.1.2.e. Visualize Data Through ThingsBoard..... 92
 - 6.2. NB-IoT/LTE CAT-M1 Application..... 95
 - 6.2.1. Connect Sensor Hub to MQTT Server..... 95
 - 6.2.2. Visualize Data Through Datacake..... 95
 - 6.2.2.a. Add SensorHub to Datacake..... 95
 - 6.2.2.b. MQTT Configuration..... 98
 - 6.2.2.c. Create a Dashboard to Visualize Data..... 104

1. Solution Overview

1.1. Description

The Water Level Monitoring Sensor Solution is an ideal tool for monitoring water levels. It comprises the RAK Sensor Hub and ULB16 water level sensor, which is suitable for use in various settings, such as hydrology exploration, water tank level measurements, and sewage.

With the plug-and-play feature of the Sensor Hub, the Water Level Solution comes with pre-installed components ready for easy installation and connection. The sensor provides highly accurate water level readings, with the Sensor Hub collecting and transmitting the data via LoRaWAN or NB-IoT/CAT M1.

The Sensor Hub's connectivity function allows for versatile data transmission to the cloud using the two most used communication protocols in IoT. This versatility ensures that data is readily available for storage, visualization, and in-depth analysis, enabling informed decision-making based on comprehensive knowledge of water levels.

1.2. Features

- Support LoRaWAN and NB-IoT/LTE CAT-M wireless communication modes
- Support LoRa frequency band: CN470, EU868, IN865, RU864, US915, AU915, KR920, AS923-1/2/3/4
- Wide measurement range: 0~200 mH₂O
- Resolution: 0.25% FS
- Easy to install and configure
- Configurable network access with the WisToolBox mobile app
- Pressure diaphragm in the probe
- Reverse polarity and current limiting protections
- Robust structure with IP68 protection rating

2. Hardware Introduction

2.1. Device List



Figure 1: Solutions package inclusion

Table 1: Package Inclusion

DEVICE LIST	DESCRIPTION
1 x Sensor Hub 1 x Mounting Kit	Sensor Hub + Sensor Hub Installation Kit
1 x Water Level Sensor 1 x Sensor Probe IO	Sensor Probe IO + Water Level Sensor
1 x Power Adapter 1 x Power Cable	Sensor Hub Power Adapter + Power Cable
1 x Cable Tie	For wiring or fixing

2.2. Hardware Specifications

2.2.1. Sensor Hub Datasheet

- For details, refer to the [Sensor Hub Datasheet](#).

2.2.2. Sensor Probe IO + Water Level Monitoring Sensor Datasheet

Sensor Probe IO Datasheet

- For details, refer to the [Probe IO Datasheet](#).

ULB16 Water Level Sensor Datasheet

Table 2: Water Level Sensor Datasheet

PARAMETER	TECHNICAL SPECIFICATIONS
DC Power Supply (default)	12 - 36 V _{DC}
Electrical Connection	Φ7.6 mm shielded cable with vent hose
Measurement Precision	0.25~0.5% FS
Measurement Range	0~1 mH ₂ O - 200 mH ₂ O
Long-Term Stability	< 0.1% FS/year
Output Signal	4~20 mA, 0~5 V _{DC} , 0~10 V _{DC} , 1~5 V _{DC}
Operating Temperature	0 - 70° C
Material of Housing	304 Stainless Steel

2.2.3. Solar Cell System Datasheet

2.2.3.a. Definition of Terms

Table 3. List of Abbreviations

ABBREVIATION	DEFINITION
BMS	Battery Management System
BMU	Battery Management Unit
BOL	Begin of Life
Bus-bar	Battery Pole Connecting Rod
CMC	Cell Manager Circuit
EOL	End of Life

HV	High Voltage
LV	Low Voltage
OCV	Open Circuit Voltage
SOC	Stage of Charge

Table 4. Terminologies

TERMINOLOGY	DEFINITION
Battery Cell	Commonly known as a battery. It is the fundamental unit of energy storage, which converts chemical energy to electrical energy.
Battery Module	Intermediate energy storage unit, comprising several individual cells and circuitry components, along with electrical and communication interfaces.
Battery Pack	A comprehensive power system consisting of multiple battery modules and circuits working together to supply power to electrical devices.
Rated Voltage	Refers to the approximate voltage value that a battery is designed to operate at or provide.
Capacity	The amount of electrical charge that a fully charged battery can store and subsequently provide to a device or system. It is typically measured in ampere-hours (Ah)
Energy Capacity	The total amount of energy that a fully charged battery can deliver under specific conditions. It is typically measured in watt-hours (Wh) or kilowatt-hours (kWh).
Rated Capacity	The minimum capacity that a fully charged battery can deliver at the beginning of its life (BOL), typically measured under specific conditions such as a discharge rate of 1C (discharge C-rate).
Unit	V : Volt, voltage
	A : Ampere, current

	Ah: Ampere-hour, charge
	Wh: Watt-hour, electrical energy
	Ω: Ohm, resistance
	°C: degrees Celsius, temperature
	mm: millimeter, length
	s: seconds, time
	kg: kilogram, weight
	Hz: Hertz, frequency

2.2.3.b. Main Specifications

Table 5. Technical Parameters

PARAMETER	TECHNICAL SPECIFICATIONS	DESCRIPTION
Battery Model	RAK9154	
Battery Cell Model	Rechargeable cylindrical lithium-ion battery H18650CH	H18650CH or equivalent product
Rated Capacity	5200 mAh	
Rated Voltage	10.8 V	Single cell voltage 3.6 V
Operating Voltage Range	9 V ~ 12.6 V	
Rated Power	56.16 Wh	
SOC Transportation Range	50 %	
Operating Temperature	Charging temperature: 0° C ~ 45° C	
	Discharge temperature: - 20° C ~ 60° C	

Storage Temperature	- 20° C ~ 60° C	More than three months @ 25° C
Working Humidity	20 ~ 80%RH	
PV Input	18 V / 1.0 A	Typical
Maximum PV Input Voltage	30 V	Open circuit voltage
Maximum Continuous Charging Current	0.2 C (1.0 A)	Limited by solar charger
Maximum Continuous Discharge Current	0.4 C (2.0 A)	
ΔVoltage	≤ 20 mV	SOC 30% ~ 60%; rest for at least 2 hours after charging or discharging
Weight	0.85 kg	
Dimensions	Length: 180 (± 3) mm Width: 130 (± 3) mm Height: 60 (± 3) mm	

2.2.3.c. Interfaces

Battery System Structure

As shown in **Figure 2**, the RAK9154 battery system comprises two sets of three 2600 mAh battery units connected in series. The system also incorporates one (1) BMS board integrated with an 18 V input solar charger.

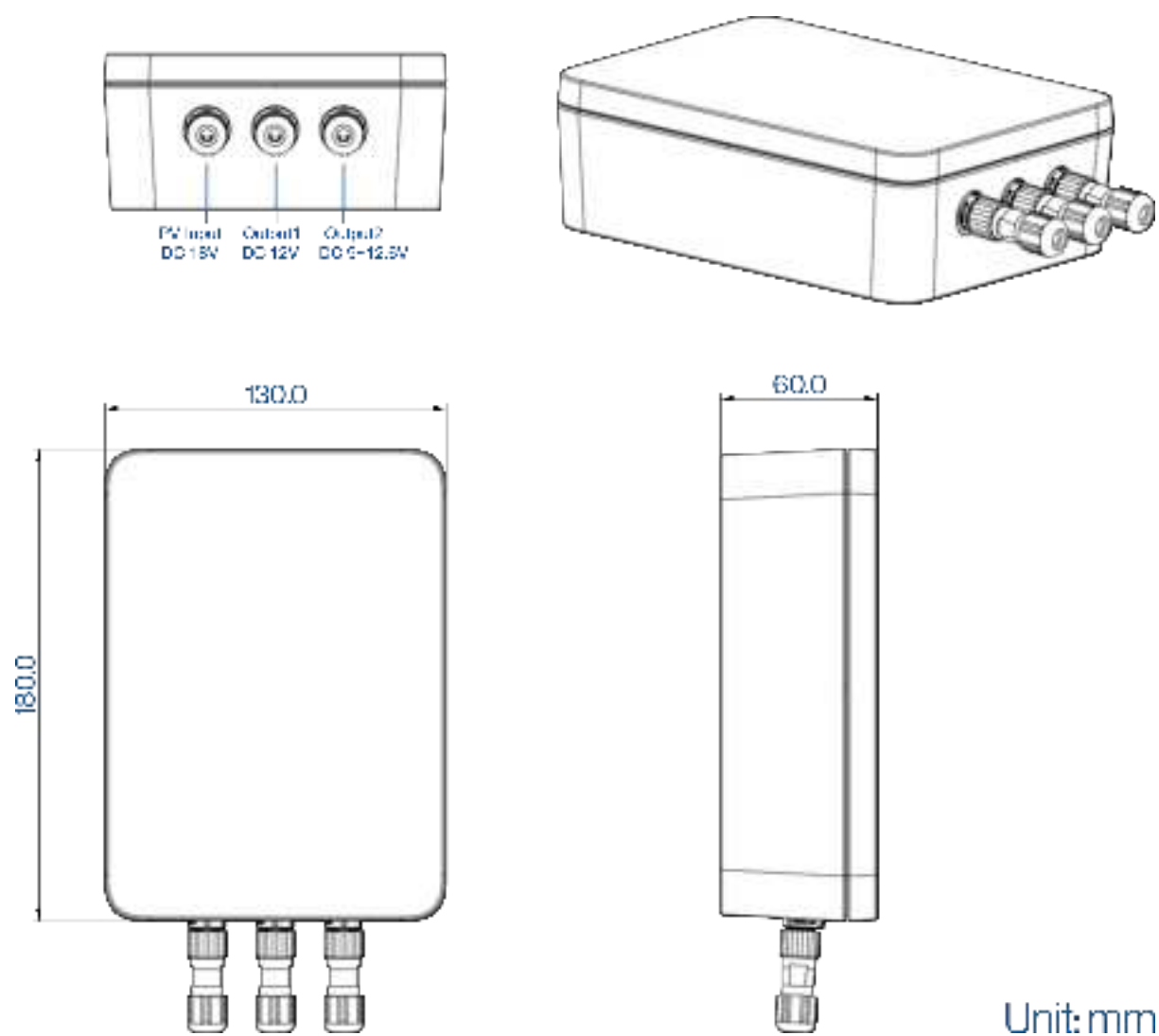

Figure 2: RAK9154 battery system

2.2.3.d. Electrical Characteristics

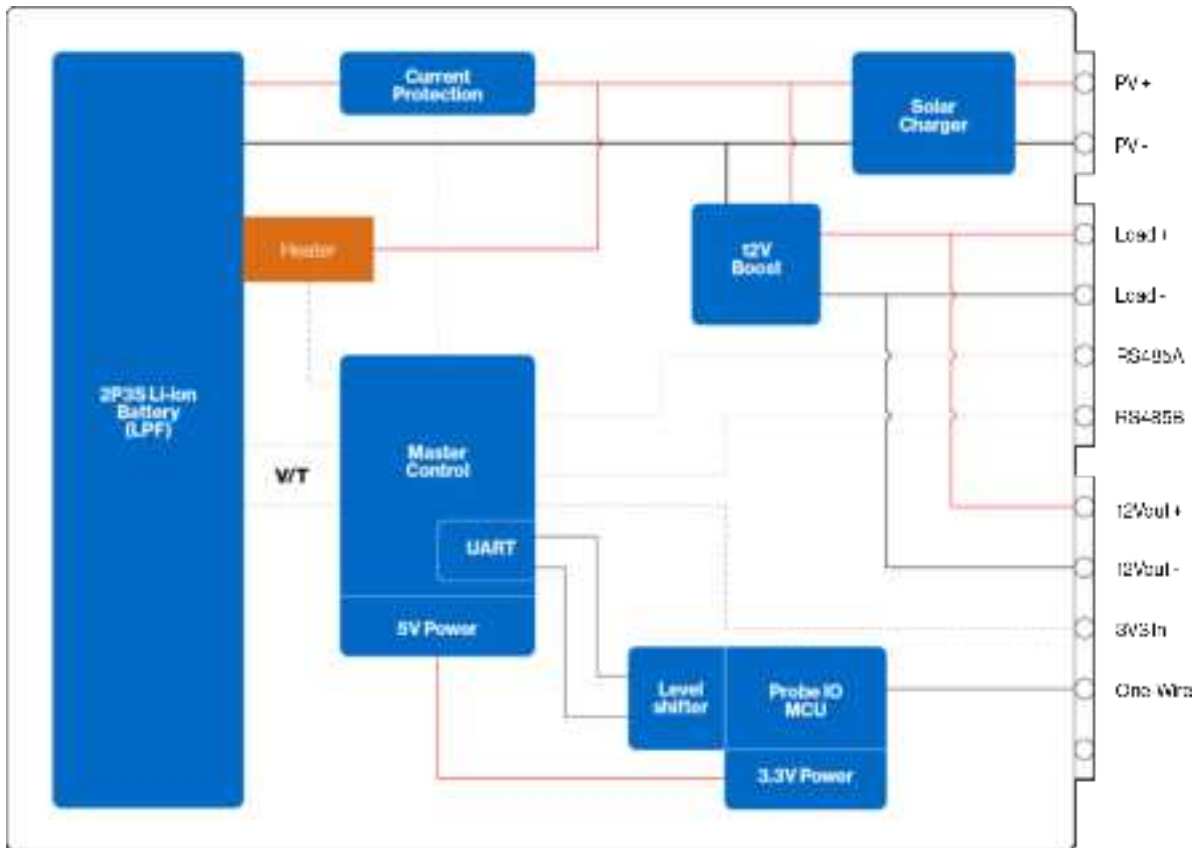

Figure 3: RAK9154 electrical diagram

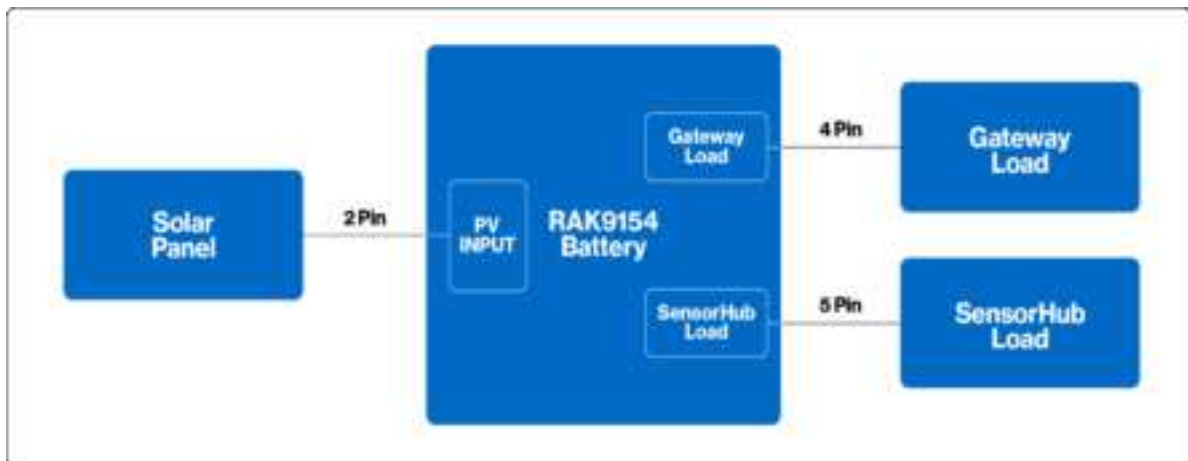

Figure 4: System circuit diagram

Table 6. Battery System Panel Connector

CONNECTOR	CONNECTOR SOCKET MODEL	CONNECTOR PLUG MODEL	DEFINITION	REMARK
Gateway Load	SP1110/P4	SP1110/P4-N	Pin1: P+	SP11 IP67 Rated Current: 2 A Contact diameter: 0.75 mm * 4
			Pin2: P-	
			Pin3: R485A	
			Pin4: RS485B	
Sensor Hub Load	SP1110/P5	SP1110/P5-N	Pin1: P+	SP11 IP67 Rated Current: 2 A Contact Diameter: 0.75 mm * 5
			Pin2: P-	
			Pin3: TXD	
			Pin4: 3V3_In	
			Pin5: RXD	
PV Input	SP1110/P2	SP1110/P2-N	Pin1: PV+	SP11 IP67 Rated Current: 1 A Contact Diameter: 1.0 mm * 2
			Pin2: PV-	

2.2.3.e. Sensor Characteristics

Table 7. Sensor Data Definition

SENSOR	SENSOR TYPE	DATA LENGTH	SCOPE	UNIT
Water Level Sensor	0x01	2	0 ~ 5	m

Table 8. Data Format

WATER LEVEL SENSOR DATA UNIT		
ID (CHANNEL)	TYPE	DATA

1 byte	1 byte	2 bytes
--------	--------	---------

Data Sample:

Payload (hex) received data: **0102 01e0**

Table 9. Water Level Sensor Data

WATER LEVEL SENSOR DATA UNIT		
ID (CHANNEL)	TYPE	DATA
01	02	01e0

Convert the sensor data from hexadecimal to decimal:

0102 (Water Level) – Data 01e0

- 01e016 = 48010
- 0x0.01 (conversion factor) = **4.8 mA**

Data Conversion

Sample:

A current range of 4~20 mA corresponds to a measurement depth range of 0~5m. The water level is converted using a proportional factor of 3.2 mA ((20-4) mA / (5-0) m) increasing the current for every 1-meter increase in depth. The monitored current value is 4.8 mA, and the current increases by 4.8 - 4 = 0.8 mA. Thus, the calculation method is as follows:

Water Level Depth = 0.8 mA / 3.2 mA x m = 0.25 m

2.2.3.f. Environmental Requirements

Transportation Requirements

 **WARNING**

- When transporting the battery, avoid severe vibrations, shaking, and exposure to sunlight or rain.
- Do not invert the battery to prevent potential short circuits.

- During loading and unloading, exercise caution to prevent the battery from falling, rolling, enduring heavy pressure, or being inverted.

Storage Requirements

Store the module in a partially charged state, typically around 40% state of charge (SOC). Ensure the storage environment meets the following requirements:

1. Temperature and Humidity

Table 10. Storage temperature and humidity

PARAMETER	VALUE	REMARK
Temperature	-30° C to 50° C	Time period < 3 months
	0° C to 25° C	Time period > 3 months
Humidity	2%RH to 90%RH	< 85% Recommended

- **Storage Environment:** Store the product in a clean, ventilated, and cool environment, avoiding direct sunlight, high temperatures, corrosive gases, severe vibration, mechanical shaking, and heavy pressure. Keep the product away from heat sources and store it at an altitude below 1500 meters, maintaining atmospheric pressure between 86 kPa and 106 kPa.
- **Maintenance:** Charge and discharge the device once a month while storing it at room temperature or in a dry and ventilated environment. If storing the device takes more than 30 days, adjust the SOC to 40% after charging.

The operation of the product must adhere to the operating instructions. Installation, maintenance, and use of the product must strictly comply with relevant safety regulations.

 **WARNING**

- Avoid storing or using the product in high-temperature environments and keep it away from heat sources. Temperatures outside the safe range can significantly reduce the performance and lifespan of the product and may even cause serious consequences such as combustion and explosion.
- Do not store or use the product in environments with high static electricity or high electromagnetic radiation. Doing so may damage the electronic components of the battery, leading to safety hazards.
- Avoid exposing the battery to water or immersing it in water. Otherwise, it may result in internal short circuits, loss of function, or abnormal chemical reactions, leading to fire, smoke, explosions, and other accidents.
- If you notice any signs of smoking, heating, discoloration, deformation, or any abnormalities during the use, storage, transportation, or servicing process, contact a professional immediately for assistance.
- Do not discard waste batteries in fires or incinerators. Waste batteries should be recycled by professional institutions or organizations.
- It is strictly prohibited to place heavy objects on the product or stack them on top of each other.
- Although this module is not a high-voltage energy storage device, improper operation and use of the device may lead to serious consequences such as combustion and explosion.
- Only professional technicians must handle the installation and maintenance of the battery system. All operations must strictly adhere to relevant safety regulations. Non-professionals are strictly prohibited from installing, maintaining, and misusing the battery system.

3. Prerequisites

Before proceeding with each step of using the Water Level Monitoring Solutions, ensure that you have the necessary items.

3.1. Hardware

- [Sensor Hub Water Level Monitoring Solution](#)
- [Solar Battery Lite for Sensor Hub](#) (Optional)
- Additional accessories: Probe Cable, Probe Splitter, Power Supply, and others (numbers and variations depending on the use case)
- An Android or iOS mobile device with Bluetooth and NFC

3.2. Software

- [WisToolBox](#)

4. Solution Configuration

4.1. Sensor Hub Setup

4.1.1. SIM Card Installation

If the selected solution utilizes the NB-IoT/LTE CAT-M wireless communication mode, follow these steps to insert a SIM card. If you opt for the LoRaWAN wireless communication mode, skip this section, as a SIM card is not required.

1. Remove the back cover by unscrewing the four screws with a cross screwdriver.

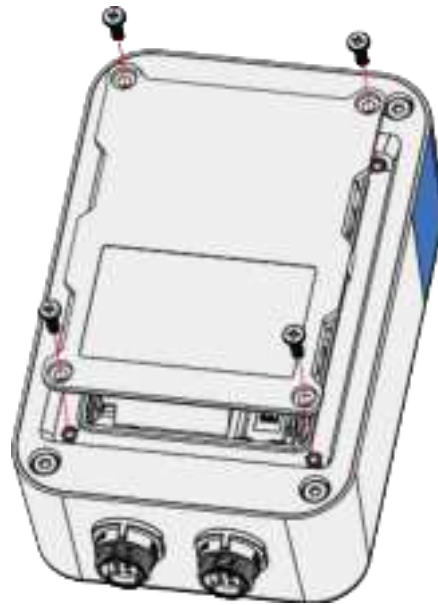

Figure 5: Remove the back cover

2. Insert the SIM card into the groove, then gently push it into the card slot.

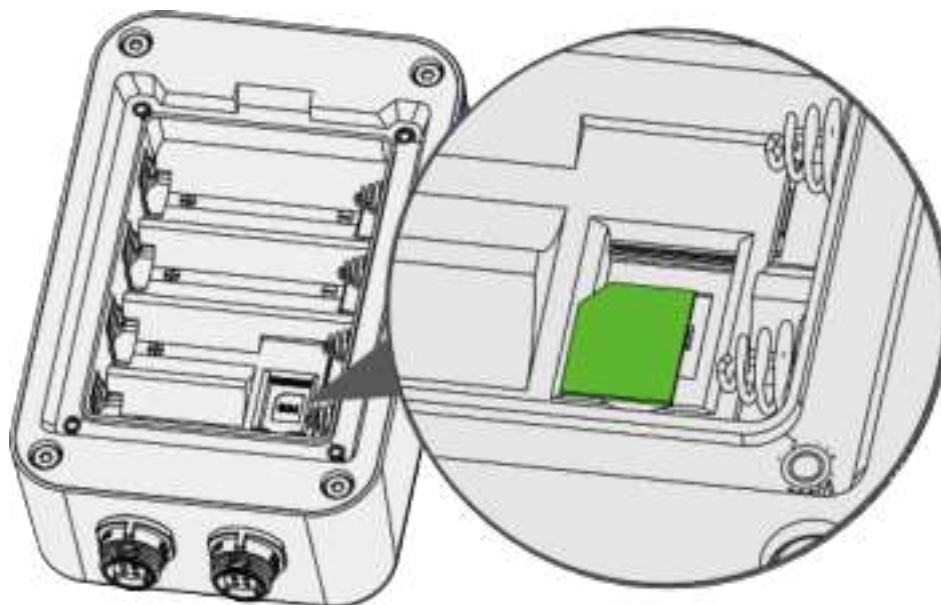

Figure 6: Insert the SIM card

4.1.2. Sensor Hub Mounting

4.1.2.a. Wall Mounting

1. Use a 5 mm drill bit to drill holes in the wall, then insert the screw anchors into the holes.

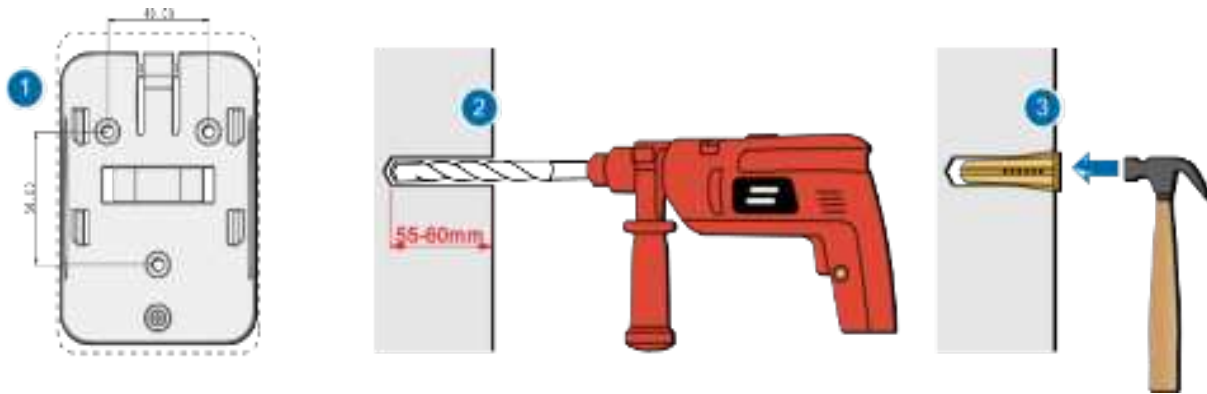

Figure 7: Installation preparation

2. Secure the mounting bracket to the wall by using self-tapping screws.

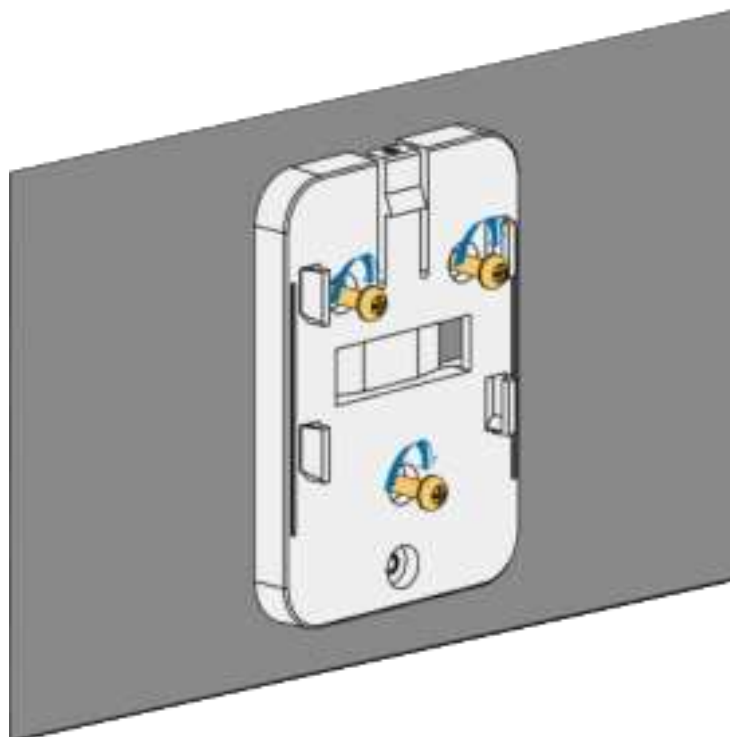

Figure 8: Install the bracket

3. Align the device's hanging tab with the slots on the bracket, and then insert the tab into the slots. Pull the device downwards until it snaps into place.

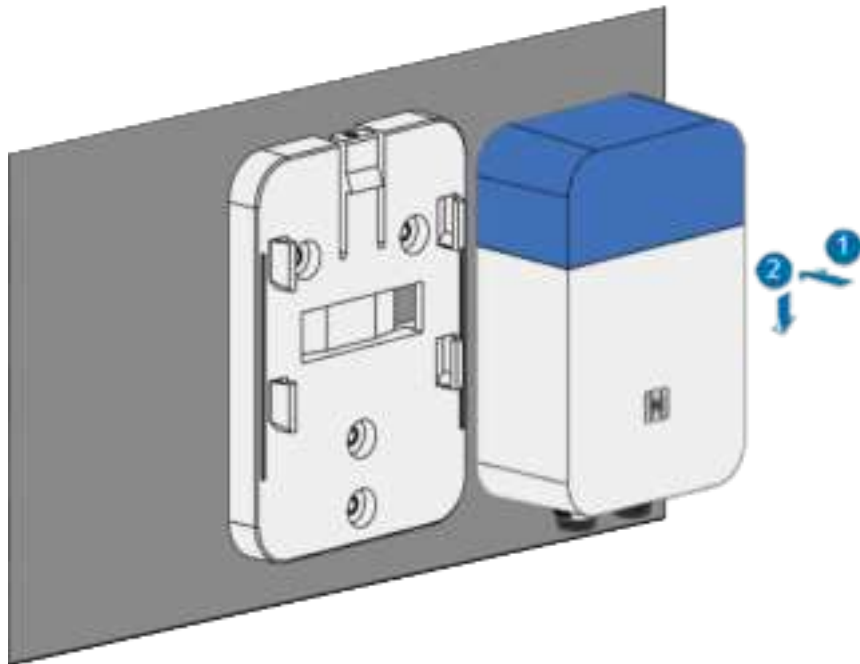

Figure 9: Align the device with the hanging tabs

4.1.2.b. Pole Mounting

1. Secure the mounting bracket to the pole using a steel strap.

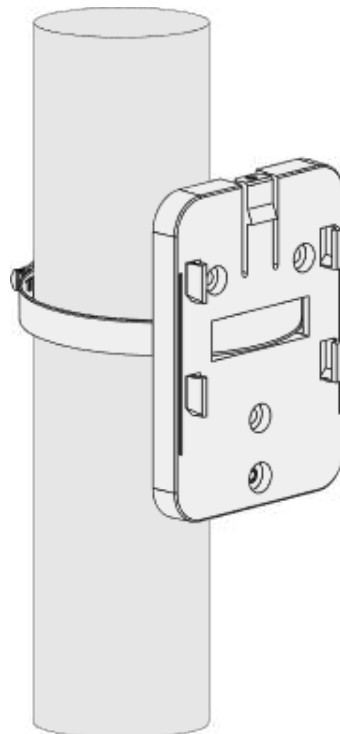

Figure 10: Fix the mounting bracket



NOTE

Mount the bracket on a pole with a 50-80 mm diameter. For larger poles, use a bigger steel strap. The standard kit does not include a larger steel strap. Purchase separately if needed.

- Align the hanging tab of the device with the slots on the bracket, then insert the tab into the slots. Gently pull the device downwards until it securely snaps in place.

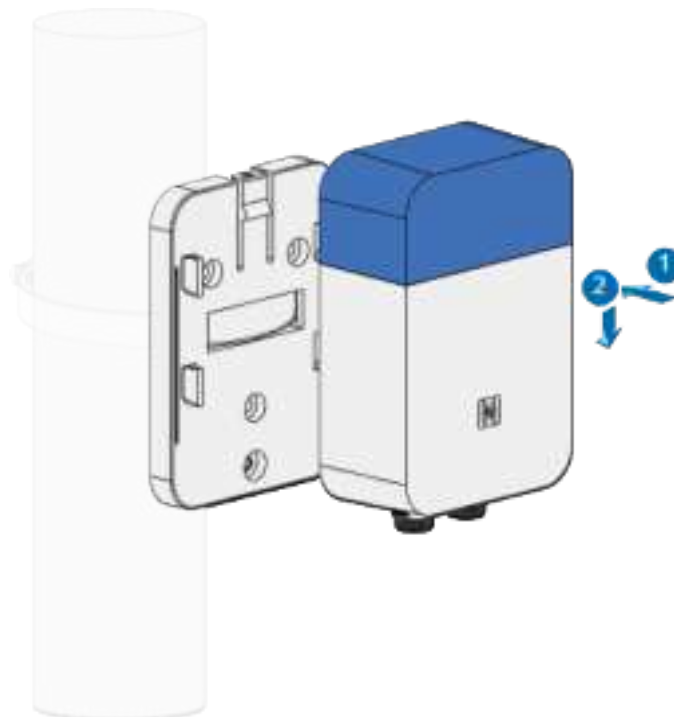

Figure 11: Device installation

- Insert a security screw at the top to fasten the device and the bracket together.



Figure 12: Fasten the device and the bracket

4.2. RAK2560 WisNode Sensor Hub + Water Level Sensor Setup

4.2.1. Sensor Probe IO + Water Level Sensor Installation

The Water Level Sensor comes pre-assembled with the Sensor Probe IO by default at the factory, so no additional assembly is required.



Figure 13: Sensor Probe IO and Water Level Sensor

4.2.2. Sensor Hub + Sensor Probe IO + Water Level Sensor

Installation

1. Connect the Sensor Probe IO to the Sensor Hub using the SP11 connector.
2. Align the white dot mark on the Sensor Probe IO SP11 connector plug with the white dot mark on the Sensor Hub SP11 connector socket and push the plug firmly into the socket.
3. Once connected, tighten the locking nut to secure the SP11 connector. The Sensor Probe IO can be linked to any Sensor Hub SP11 connector port.

Refer to the actual use and connect to the appropriate port as illustrated in **Figure 14**.



Figure 14: Connect the Sensor Probe IO



Figure 15: Installation completed

4.3. Power Supply Setup

The Sensor Hub relies on the Sensor Probe IO for connectivity to the Water Level Monitoring sensors. Consequently, it cannot be powered by batteries alone and requires a connection to either a solar panel or a 12 V_{DC} power supply for operation.

4.3.1. RAK9154 Solar Battery Installation



NOTE

Mount the bracket on a pole with a 50-80 mm diameter. For larger poles, use a bigger steel strap. The standard kit does not include a larger steel strap. Purchase separately if needed.

1. Secure the mounting bracket to the pole using two steel straps.

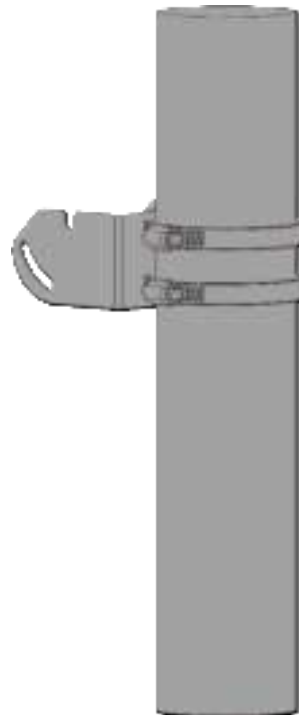

Figure 16: Secure the mounting bracket

2. Attach the mounting plate to RAK9154 using two (2) M3 screws.

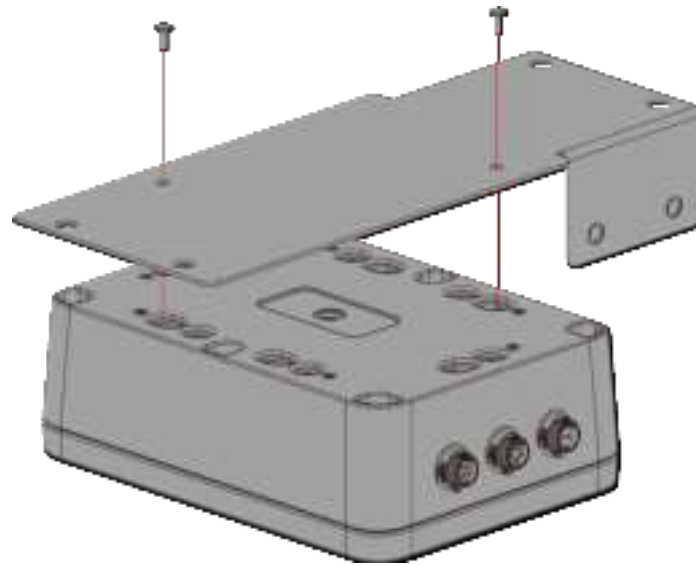

Figure 17: Attach the mounting plate

3. Install the RAK9154 to the back of the solar panel using four (4) screws and nuts.

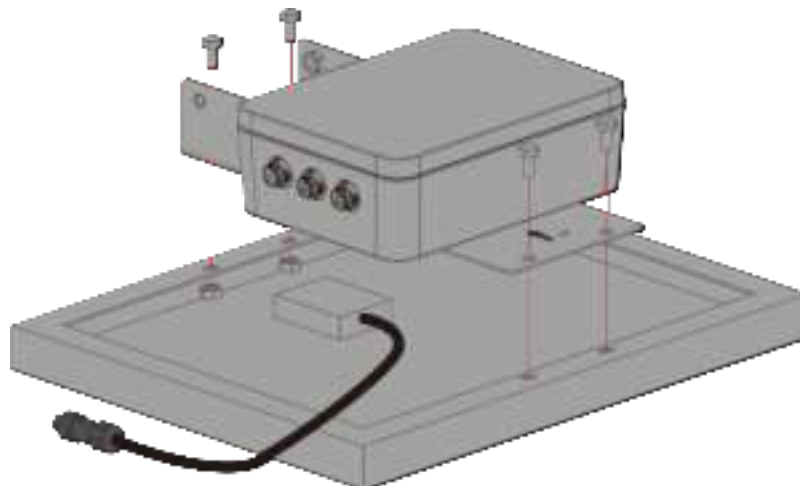

Figure 18: Attach RAK9154 to solar panel

4. Connect the cable of the solar panel to the PV Input connector of RAK9154. Install two (2) M6 screws on the mounting plate with a clearance of about 3 mm.



Figure 19: RAK9154 and Solar Panel Connection

5. Suspend the solar panel on the mounting bracket, adjust its angle and direction, and then tighten the two (2) M6 screws along with the remaining two screws.

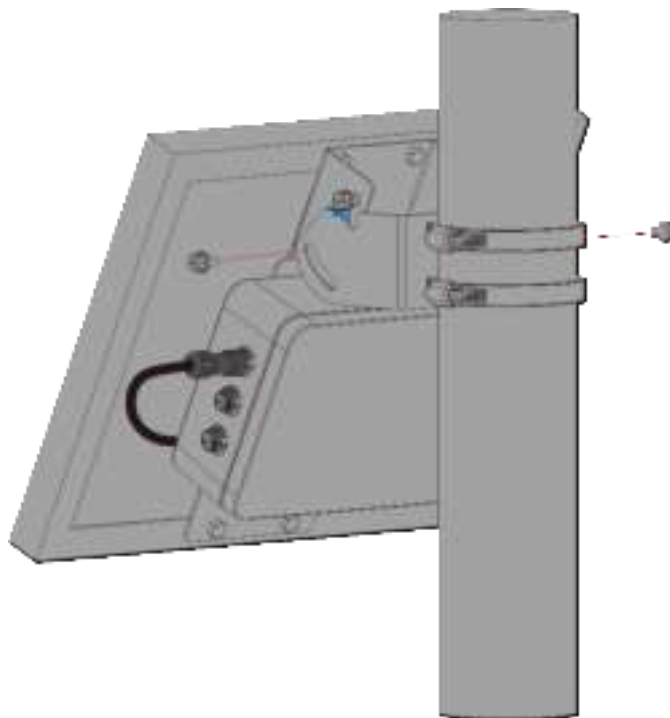

Figure 20: Install the solar panel combination

6. Connect the Sensor Hub to the RAK9154. Use a cable to link the remaining connection ports of the Sensor Hub to the lithium battery Output 1 SP11 connection port of the RAK9154.

 **NOTE**

When connecting to RAK9154, ensure that the Sensor Hub is connected to the Output 1 connection port.

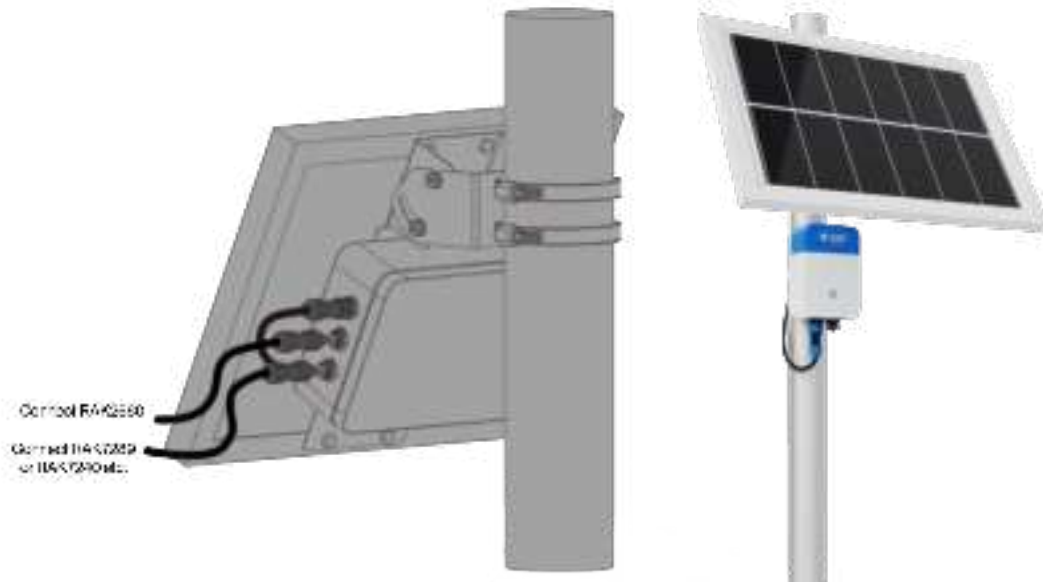

Figure 21: Connect Sensor Hub and RAK9154

7. Once the connection is complete, the Sensor Hub is ready to be powered up.

4.3.2. 12 V_{DC} Power Supply Installation

1. Connect the power adapter and the external power cable of the Sensor Hub through the circular DC interface.



Figure 22: Power Adapter Connection

2. Connect the external power cable of the Sensor Hub to the Sensor Hub through the SP11 connector.
3. Align the white dot mark on the SP11 connector plug of the external power cable with the white dot mark on the Sensor Hub SP11 connector socket and push the plug firmly into the socket.
4. After the plug and socket are connected, tighten the locking nut to secure the SP11 connector. The external power cable can connect to any Sensor Hub connection port.



Figure 23: Connect the external power cable

5. Software Configuration Guide

5.1. Sensor Hub Configuration

5.1.1. Power Up Sensor Hub

After installing all hardware components, connect the power supply. If the power supply consists of a solar panel and a battery, the device will power on automatically once all hardware has been installed.



To prevent damage to the device, refrain from powering up the Sensor Hub before connecting it to the sensor. It is advisable to use the 12 V_{DC} adapter provided with the Sensor Hub for optimal performance.

5.1.2. Connect Sensor Hub to WisToolBox

1. Download and install the WisToolBox app on your smart mobile device. The WisToolBox app is available for download from the Apple [App Store](#) and the Android [Google Play Store](#).
2. Initiate the app and confirm that NFC and Bluetooth are enabled on your mobile device. Click on **START**.



Figure 24: Start the App

3. On the **Select connection mode** menu, choose **NFC Activation**.

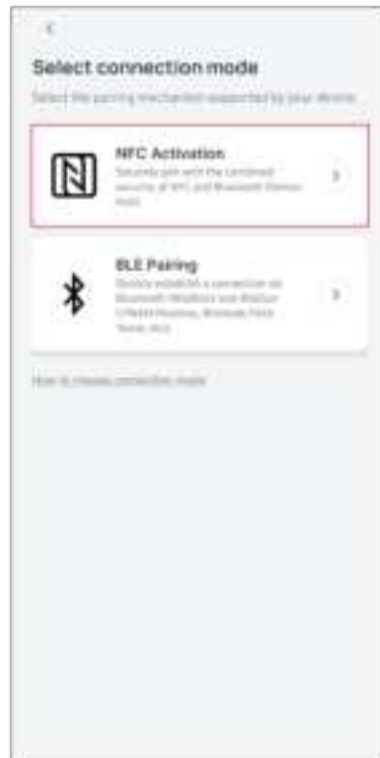

Figure 25: Select **NFC Activation**

4. Select the **Sensor HUB** option in the device selection interface to establish a connection.



Figure 26: Select **Sensor Hub**

- Click the **CONNECT** button to initiate the scanning process for devices.



Figure 27: Click on the **CONNECT** button

- Hold your mobile device close to the **N** symbol on the Sensor Hub device.



Figure 28: Scanning in progress



NOTE

The detection of the Sensor Hub device indicates that the device has been successfully powered up.



Figure 29: Scan Successful

7. After the connection is established, there will be a synchronization of device data. This process may take some time.



Figure 30: Sync Device



NOTE

- By default, if no connection is established within 30 seconds, the BLE broadcast of the Sensor Hub will automatically shut down. To establish a connection, connect the RAK device immediately after turning on the power or restart the power.
- Certain Android smartphones may necessitate enabling GPS to connect to BLE. Enabling GPS does not involve the use or sharing of sensitive information with the app.

8. Upon completion of data synchronization, the app will automatically transition to the **SENSOR HUB INFO** page.



Figure 31: **SENSOR HUB INFO** page

9. While on the **SENSOR HUB INFO** page, configure the **Uplink Settings** according to the selected network.



Figure 32: Uplink Setting option

10. Once configured, click **SAVE SELECTION** and then the **APPLY** button to implement the configuration options.

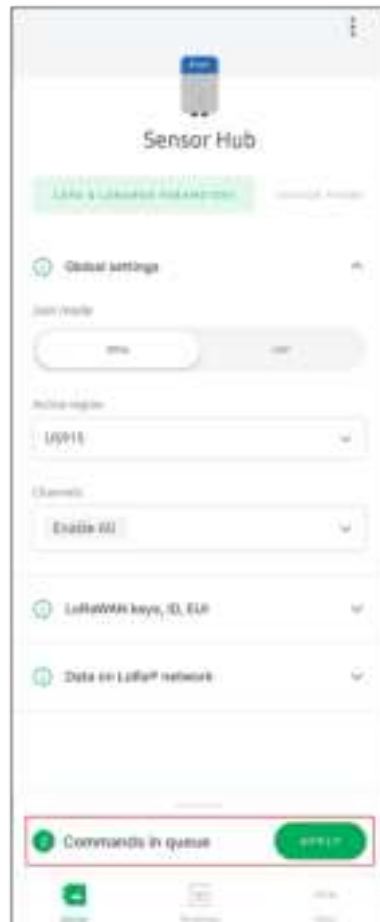

Figure 33: Apply the configuration options

After a few seconds, the synchronization progress will be completed, concluding this process.



Figure 34: Commands applied successfully

5.1.3. Sensor Hub Network Configuration

5.1.3.a. LoRaWAN Configuration

This section focuses on configuring LoRaWAN parameters and joining the network. Before proceeding with the following steps, ensure that both the gateway and Sensor Hub are successfully connected to the server.

Refer to the **Connect Gateway to TTN** and **Connect Sensor Hub to TTN** sections for detailed instructions.

1. Click on the **LORA & LORAWAN PARAMETERS** tab. Configure the following parameters:

Global Settings

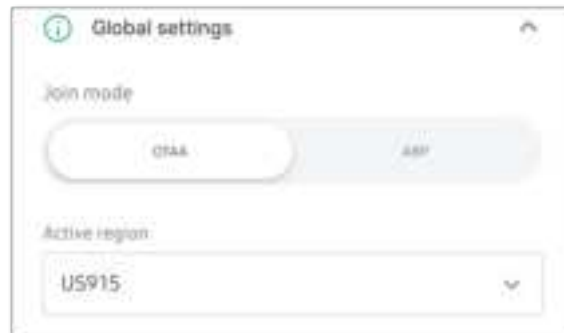

Figure 35: Global Settings

- **Join Mode:** Configure the Join mode based on the device's network access mode: **Over-The-Air Activation (OTAA)** or **Activation By Personalization (ABP)**. Make sure it matches the join mode registered on the network server.
- **Active Region:** Set the Active region to the device's frequency plan. Ensure that it is consistent with the gateway and device frequency plan registered on the network server.
Supported frequency bands include CN470, RU864, IN865, EU868, US915, AU915, KR920, AS923-1/2/3/4.

LoRaWAN keys, ID, EUI

- For the **OTAA join mode**, configure the following parameters: **Application EUI**, **Application key**, and **Device EUI**.



Figure 36: LoRaWAN parameters

- **Application EUI:** Confirm that it matches the device's Application EUI as registered in the network server.
- **Application Key:** Verify its alignment with the device's Application key registered in the network server. Click **GENERATE KEY** to create a new key if needed.
- **Device EUI:** Confirm that it matches the Device EUI registered in the network server.
- For the **ABP join mode**, configure the following parameters: **Application session key**, **Device address**, and **Network session key**.

The screenshot shows a configuration window titled "LoRaWAN keys, ID, EUI". It contains three input fields with their respective character counts and current values:

- Application session key:** 32/32 characters, value: 00000000000000000000000000000000
- Device address:** 8/8 characters, value: 00000000
- Network session key:** 32/32 characters, value: 00000000000000000000000000000000

Figure 37: LoRaWAN parameters

Data on LoRa® network



Figure 38: Data on LoRa® network

- **Confirm mode:** Message confirmation mode.
 - **Enable Auto Join:** Determine whether to activate automatic network access. When enabled, the device will join the network automatically upon powering up.
 - **Network Status:** Indicates the status of the network connection. It will be activated automatically once successfully connected to the network.
 - **ADR:** Adaptive Data Rate. Click the button to toggle between enabling and disabling it.
 - **JOIN NETWORK:** Once the network parameter configuration is finished, click the JOIN NETWORK button to instruct the device to execute the join network command.
2. After clicking **JOIN NETWORK**, a message **Message sent** will appear, indicating that the join network command has been sent.

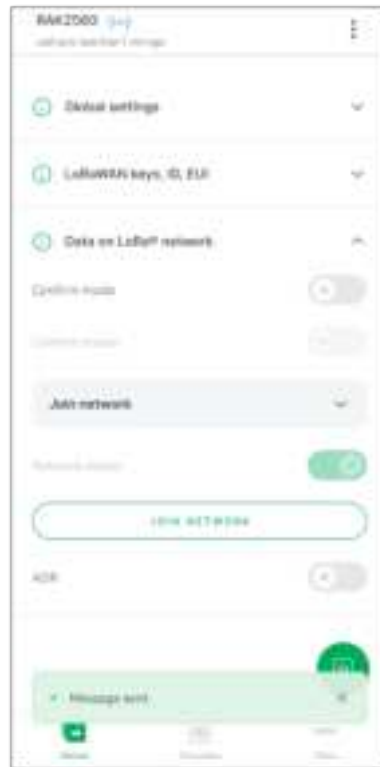

Figure 39: Join the network

5.1.3.b. NB-IoT/LTE CAT-M1 Configuration

This section primarily introduces the configuration of LTE-M network parameters. If you are using the NB-IoT/LTE CAT-M1 network, after connecting the device, select **LTE-M** in the **Uplink Settings** options on the **SENSOR HUB INFO** interface to display the **LTE-M PARAMETERS** configuration tab.

1. Click the **LTE-M PARAMETERS** tab. Check the following parameters to ensure the normal use of the network.



Figure 40: View the **NB-IOT PARAMETERS** tab parameters

NB-IoT Network

- **OPERATOR:** Shows the Network operator. If the operator's name is displayed, it indicates that the device has recognized the SIM card. For example, *T-Mobile*.

IP Network

- **STATUS:** If the status is **Activated**, it signifies that the network of the SIM card is functioning normally.

2. Select the **Application** option to set up the cellular network parameters.

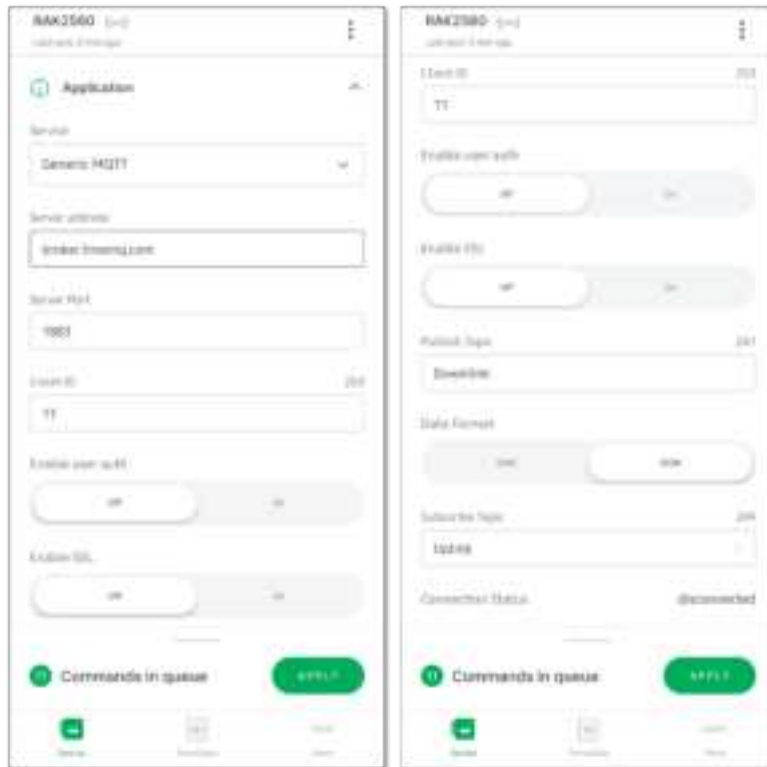

Figure 41: Configure the cellular network parameters

- **Service:** Choose a service, either AWS IoT Core or Generic MQTT. Let's take Generic MQTT as an example.
- **Server address:** Input the server address. Using the external MQTT broker as an example, enter *broker.hivemq.com*. Enter the address based on your specific use case.
- **Server Port:** Specify the server port according to your configuration.
- **Client ID:** Set the client ID for your device.
- **Enable user auth:** Decide whether to activate user authentication for your device.
- **Enable SSL:** Decide whether to activate SSL (Secure Sockets Layer) for secure communication.
- **Publish Topic:** Specify the topic for publishing messages.
- **Data Format:** Select **JSON** as the preferred format for data transmission.
- **Subscribe Topic:** Subscribe to the topic for receiving incoming messages, as illustrated in this example.

- Following the configuration, click **APPLY** in the command list at the bottom of the interface to implement the changes. If the message **All commands applied successfully** appears, it indicates a successful configuration modification.

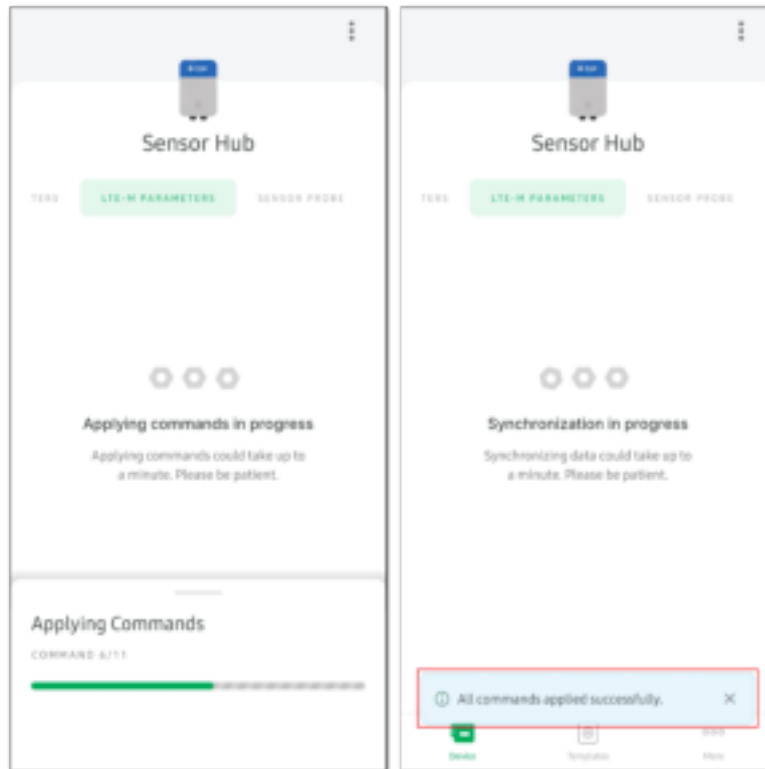

Figure 42: Apply the modified configuration

- When configured correctly and successfully connected to the server, the **Connection Status** will show as **connected**.



Figure 43: Successfully connected to the server

5.1.4. Sensor Configuration

This section details the configuration process of the Water Level sensor. It shows how to access the monitoring data and device details of the Water Level sensor. Additionally, there's an option to configure other information for each monitoring parameter, such as the uplink data sending period and threshold.

1. To start with, click the **SENSOR PROBE** tab to display the connected water level sensor.



Figure 44: Water Level sensor

2. Click the dropdown arrow to expand the details of the water level sensor.

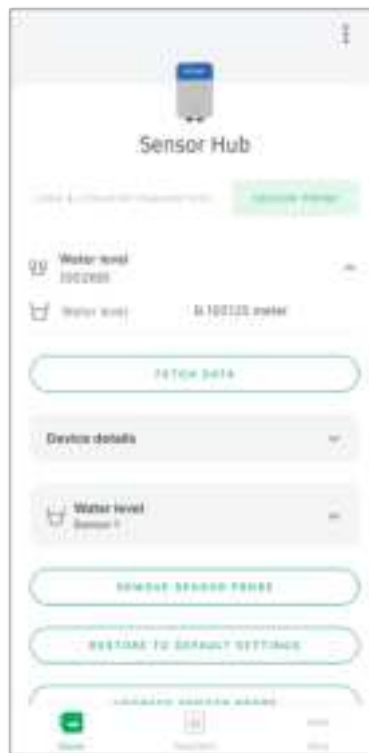

Figure 45: Sensor Information

- **Water level**
- **FETCH DATA:** Update the monitoring data from the sensor.
- **Device details:** Device details of the Water Level sensor.



Device details	
Probe ID	1
Hardware	VC
Firmware	V1.2.6
Hardware model	RAK2560-io
Probe serial	00269
Probe type	MA01

Figure 46: Sensor details

3. Configure the periodic uplink data sending, threshold, and other pertinent information of the sensor.



Figure 47: Set the sensor parameters

- **Sensor Data:** Information provided by the sensor.
- **FETCH DATA:** Update the latest sensor data.
- **Send uplink if value changes:** Send uplink data if the sensor data changes.
- **Sensor interval(s):** The payload sending interval in seconds. It determines how often the sensor sends uplink data to the server, with a range interval from 60~86,400 seconds. Set this parameter when the **Send periodic uplink** is enabled.
- **Send periodic uplink:** Send uplink data periodically based on the sensor interval.
- **Lower threshold, meter:** Specifies the minimum acceptable water level.
- **Send uplink if below threshold:** Send uplink data if the value falls below the lower threshold.

- **Upper threshold, meter:** Maximum acceptable value.
 - **Send uplink if above threshold:** Send uplink data if the value exceeds the upper threshold.
 - **Threshold, meter:** Range of acceptable values.
 - **Send uplink if within threshold:** Send uplink data if the value falls within the specified threshold range.
4. After completing the modifications, a message **Commands in queue** will appear at the bottom of the interface. Click **APPLY** to send the parameter update commands.



Figure 48: Apply commands

5. When the message **All commands applied successfully** appears on the interface, it indicates that the parameter update commands have been successfully sent.

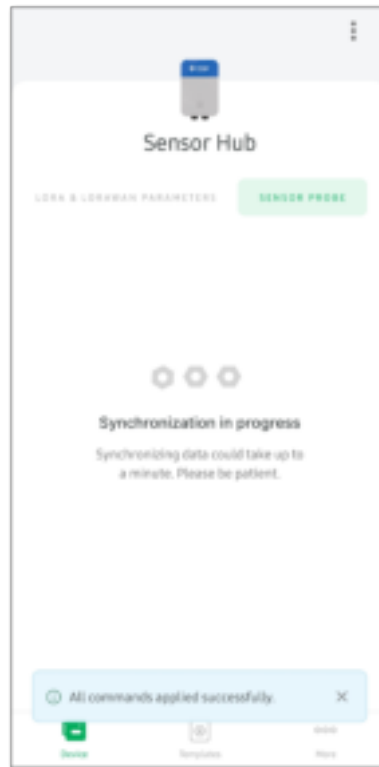

Figure 49: Commands applied successfully

Other Operations

- **REMOVE SENSOR PROBE:** Detach the sensor.
- **RESTORE TO DEFAULT SETTINGS:** Reset the Sensor Probe to its default settings.
- **UPGRADE SENSOR PROBE:** Upgrade the firmware of the Sensor Probe.

6. Network Server and Visualization Configuration

This section outlines the operational steps for connecting the device to the network server in both the LoRaWAN and NB-IoT application scenarios.

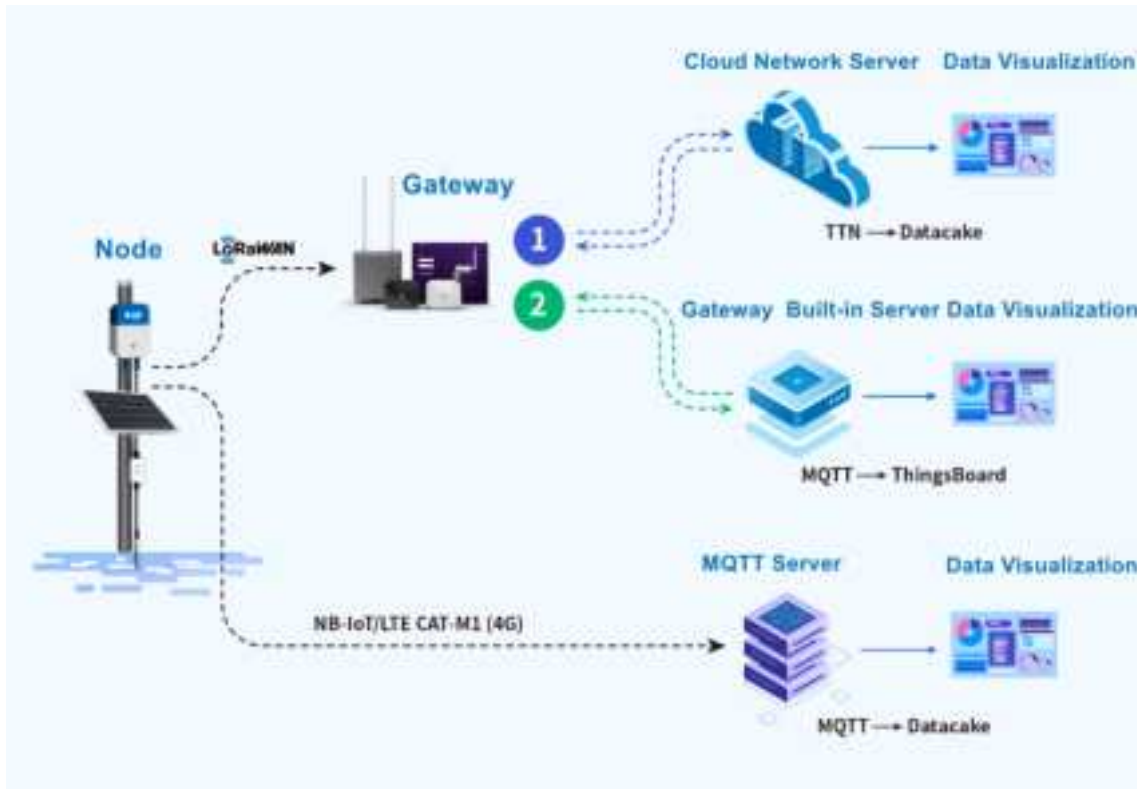

Figure 50: LoRaWAN application scenario

6.1. LoRaWAN Application

6.1.1. Cloud Network Server Setup

The cloud network server deployment scenario involves connecting the gateway and devices to third-party cloud network servers. This setup integrates visualization applications to manage real-time Water Level data.

This section provides instructions on creating a Datacake visualization application using the TTN v3 cloud network server.



Figure 51: Cloud network server deployment solution

6.1.1.a. Connect Gateway to TTN

For this example, you will use the TTNv3 cloud server and RAK7289V2 WisGate Edge Lite 2 to demonstrate how to connect the RAK business gateway to a cloud server.

Register the Gateway

1. Register an account and log in to the [TTN v3 website](#). If you already have a TTN account, you can log in using your **The Things ID** credentials.



Figure 52: Log in to the TTN website

2. Once logged into the site, click on **Register a gateway** to begin the registration process for a new gateway.

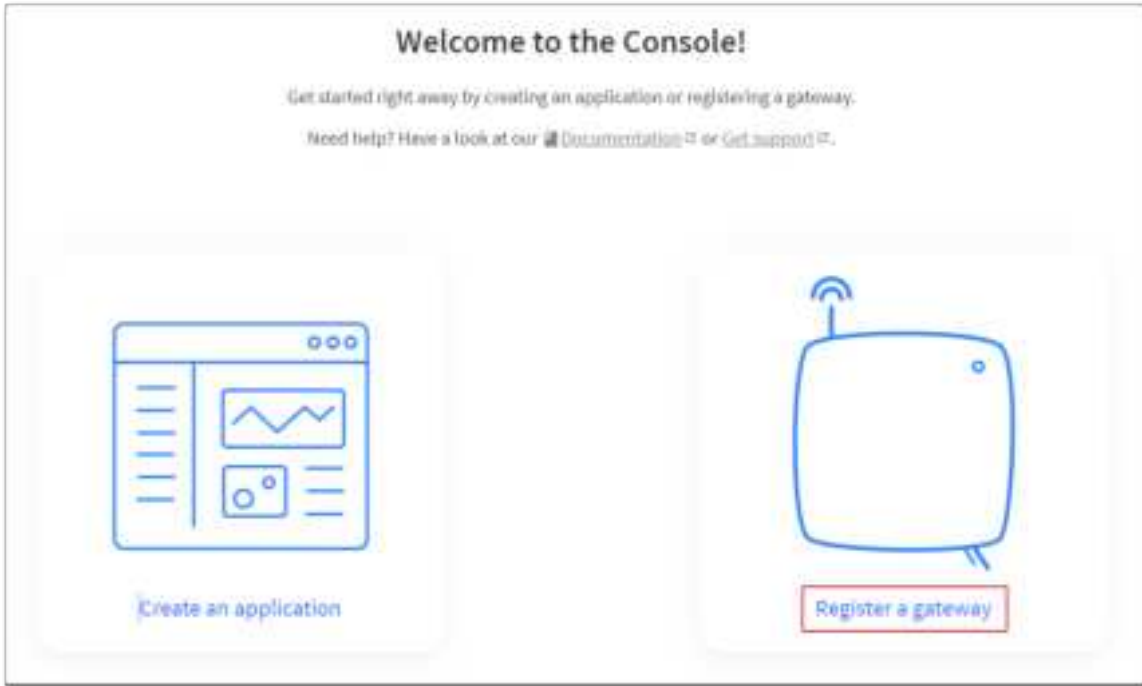

Figure 53: TTN home page

3. Input the Gateway EUI and then click on **Confirm** to proceed.

The Gateway EUI serves as a distinct 64-bit extended identifier for the gateway, accessible from the Overview page of the gateway management platform or from the label situated behind the gateway.

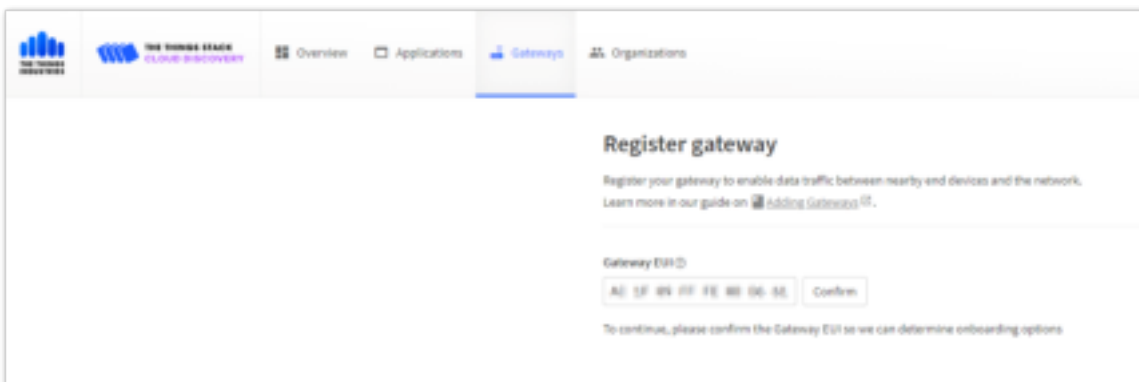

Figure 54: Enter the Gateway EUI

4. Choose the frequency plan utilized by the gateway and click **Register gateway** to complete the registration process of the gateway.

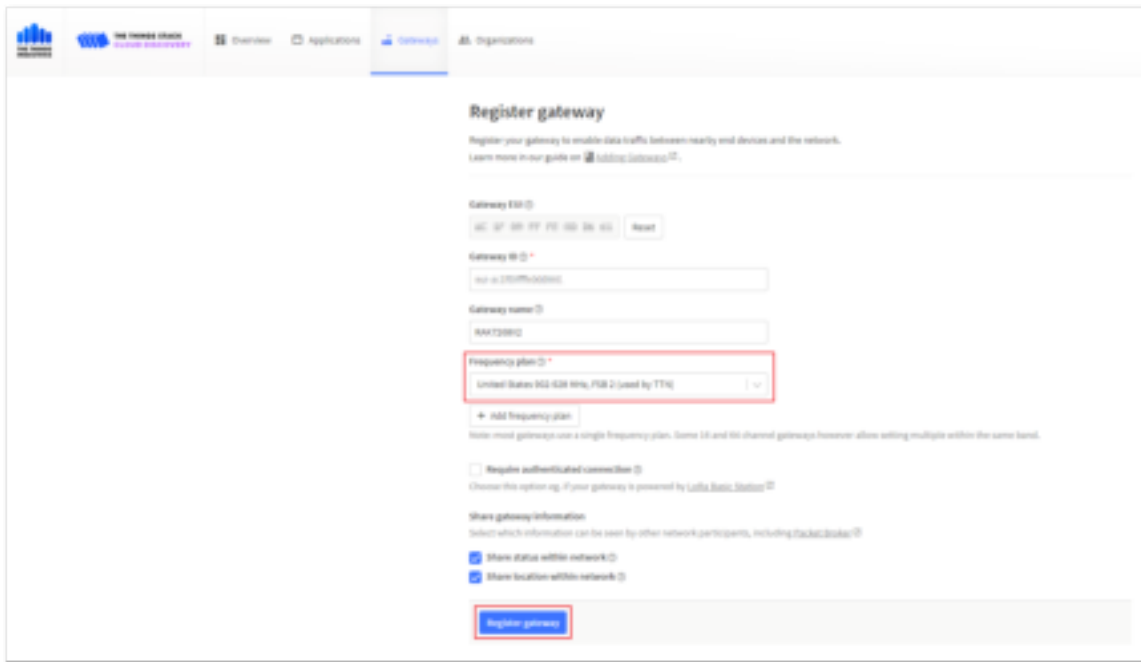

Figure 55: Configure the gateway frequency

Your gateway dashboard should look the same with **Figure 56**.



Figure 56: Successfully registered the gateway

Generate a Token

TTNv3 supports TLS server authentication and client tokens, which require trust files and keys to configure the gateway and successfully connect to the network.

1. To generate a key file, navigate to **API keys** from the **Overview** page of the registered gateway. then click on **Add API key**.



Figure 57: Add API keys

- In the **Add API key**, set the **Name** field, tick off the checkboxes, then click **Create API key**.



Figure 58: Configure the API Key

- A new window pops up with the generated key. Copy the new API key by clicking the icon and then the **I have copied the key** button.

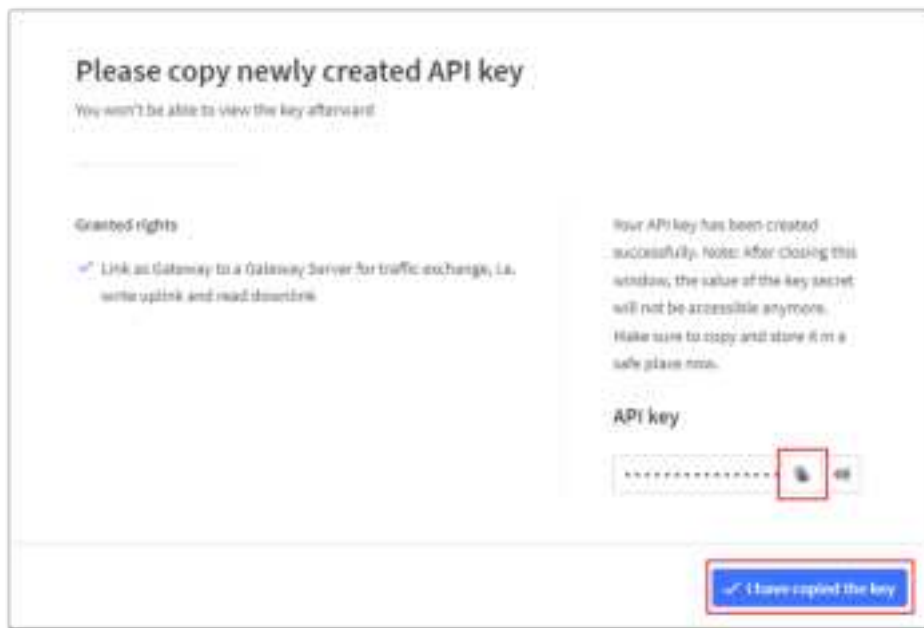

Figure 59: Copy and save the API Key

Configure the Gateway

1. Navigate back to the gateway management platform Web UI. Click on the left navigation bar to access the **LoRa > Configuration** tab. Complete the following settings and save them.
 - **Basics Station Server Type:** LNS Server
 - **Server URL:** wss://eu1.cloud.thethings.network
 - **Server Port:** 8887
 - **Authentication Mode:** TLS server & Client Token Authentication
 - **Trust (CA Certificate):** Download the [certificate](#)
 - **Client Token:** Copied API Keys

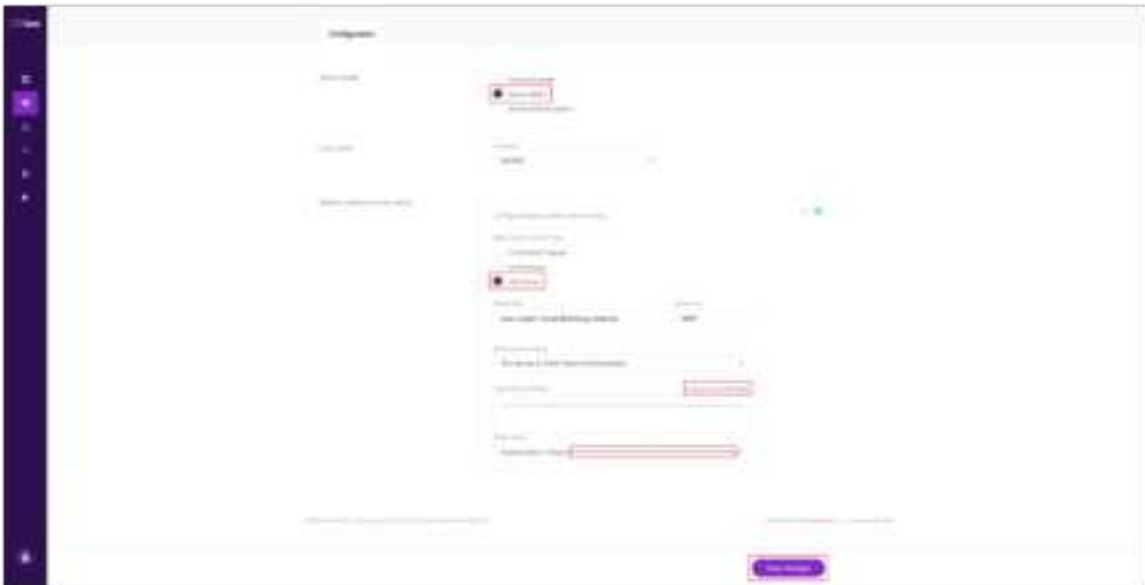

Figure 60: Configure the gateway

2. After saving the changes, return to the TTN gateway interface, and navigate to the **Gateways** tab to confirm that the gateway is now connected to TTNv3 as a Basics Station.



Figure 61: Gateway connected successfully

6.1.1.b. Connect Sensor Hub to TTN

1. Return to the TTNv3 homepage and select **Create an application** to add a node.

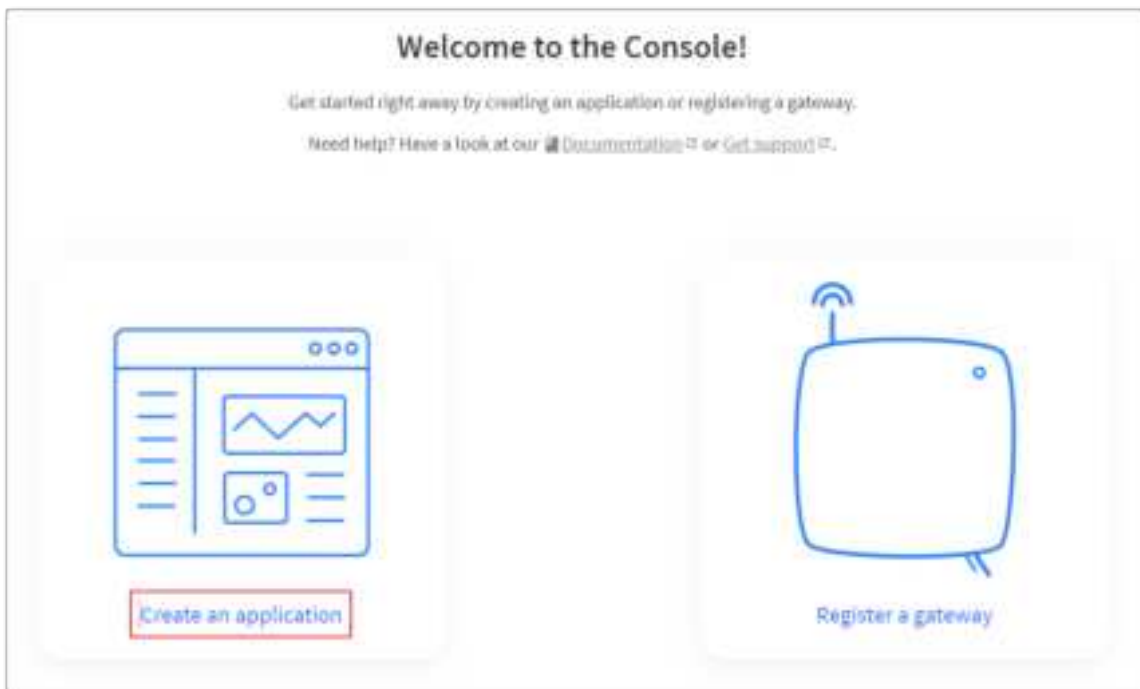

Figure 62: Select Create an application

2. Click on **+Create application** to initiate the process of creating a node.



Figure 63: Create a new application

3. Enter the desired **Application ID** in the provided field, then click on **Create application**.



Figure 64: Enter the application ID

4. Click on the **+Register end device** button to add a new end device to the application.



Figure 65: Add the end device

5. Set the parameters of the end device as illustrated in **Figure 66**.



Figure 66: End device parameters

- **JoinEUI**, **DevEUI**, and **AppKey** can be automatically generated by clicking **Generate** on the TTN web page or customized by the user.

 **NOTE**

Ensure that the three parameters - **JoinEUI**, **DevEUI**, and **AppKey** - are consistent with the parameters set in the WisToolBox application.

6. After completing the settings, return to the WisToolBox app, and click **JOIN NETWORK** to send the end device network access request.

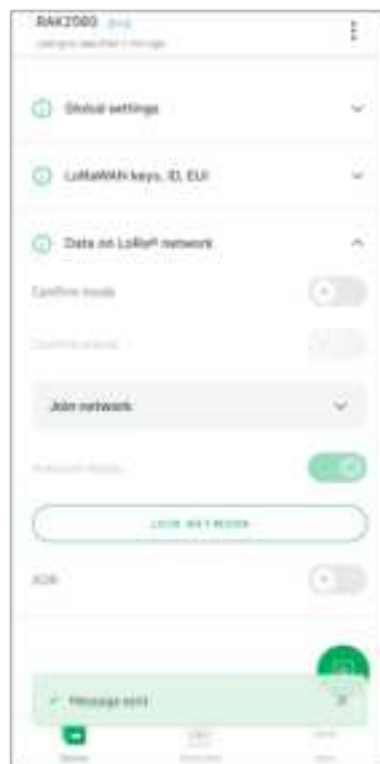

Figure 67: Sending end device network join request

7. As depicted in **Figure 68**, the Sensor Hub has successfully joined the TTNv3 network server.

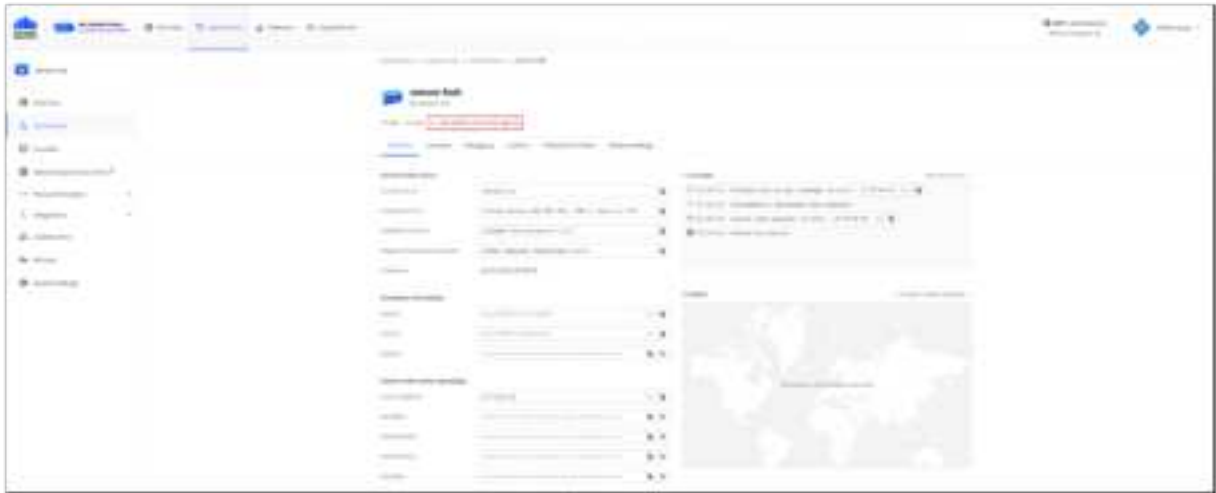

Figure 68: Successfully joined the TTNv3 network server

6.1.1.c. Visualize Data Through Datacake

Datacake is a versatile IoT platform. It offers a range of features tailored for effective data visualization and management, making it a preferred choice for IoT projects requiring efficient monitoring and analysis.

Create Datacake Integration

1. In the TTN console, navigate to **Integrations** on the sidebar, proceed to the **Webhooks** section, and then click **+Add Webhooks** to set up an integration.



Figure 69: Adding an integration

2. From the list of webhook templates, select the **Datacake** template.

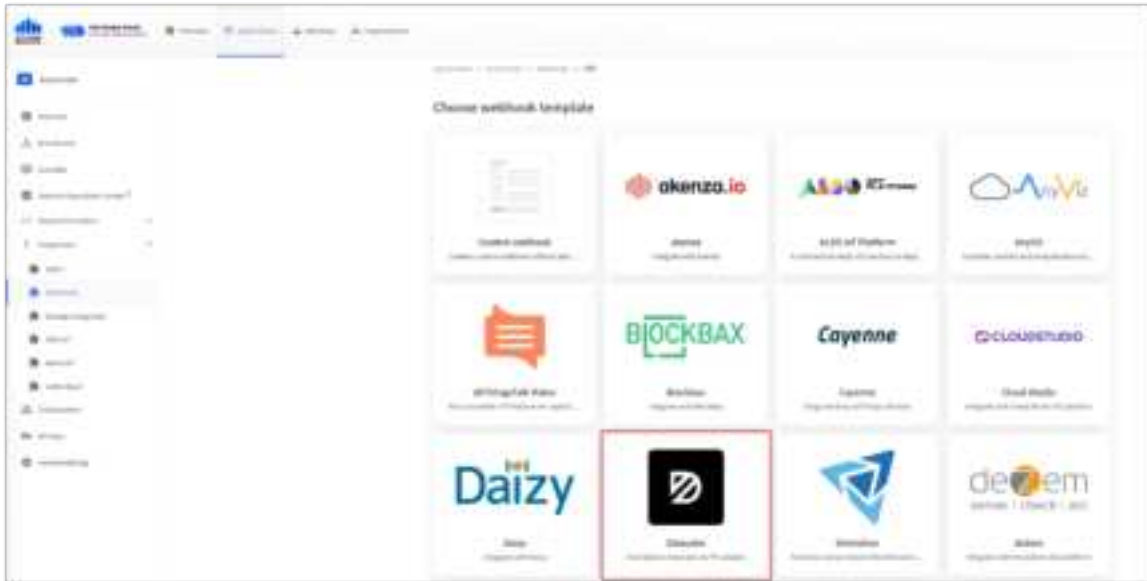

Figure 70: Select the **Datacake** template

3. Generate an API key for webhook authentication on Datacake. To get started, register a [Datacake](#) account, and then log in.



Figure 71: Datacake IoT platform main page

4. Navigate to the Datacake workspace. Select **Members** on the sidebar, switch to the **API Users** tab, and then click the **Add API User** button.



Figure 72: Add API User

5. Enter the name of the API User, for instance, **TTS API**. Set the relevant parameters accordingly and click **Save** to finalize the creation process.

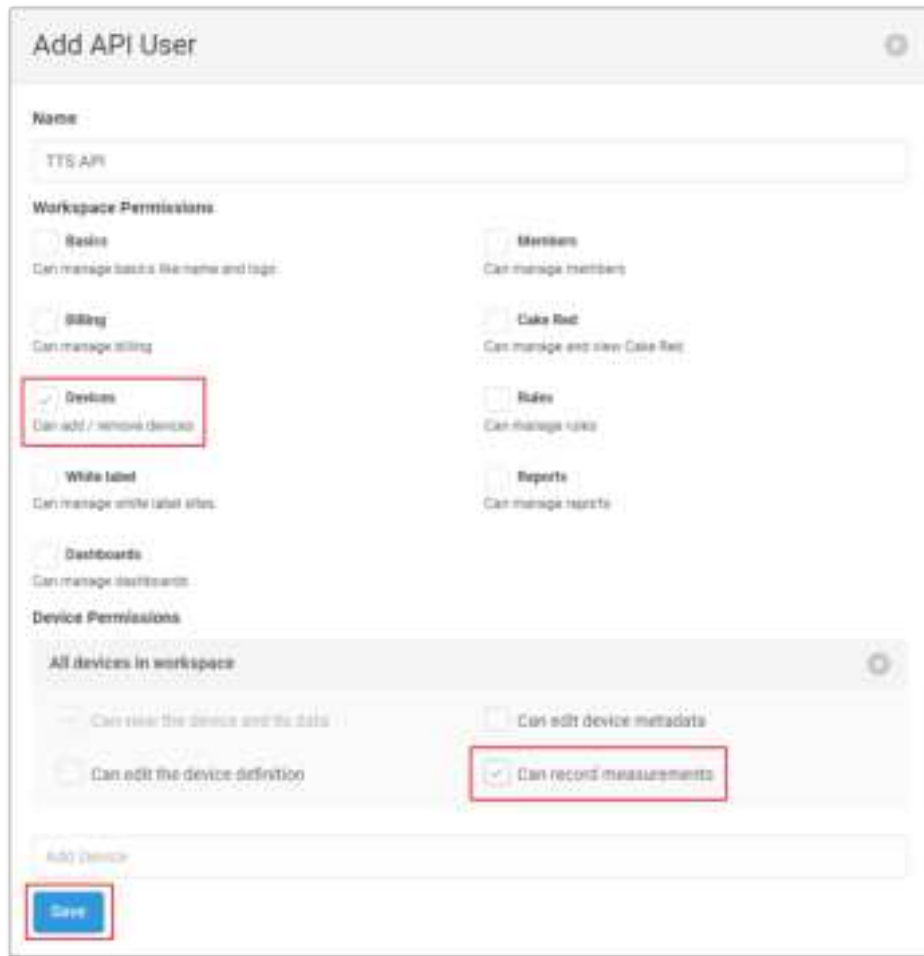

Figure 73: Set Parameters

- Click the **Copy** button to copy the generated Datacake API Token.



Figure 74: Copy the generated Datacake API Token

- Back on the TTN website, enter **sensorhub** in the **Webhook ID** field (as an example), and paste the Datacake API Token you previously copied into the **Token** field. Click the **Create Datacake Webhook** button to generate the Datacake Webhook.



Figure 75: Create the Datacake Webhook

Add Sensor Hub to Datacake

1. To add a new device, select **Devices** in the sidebar and click the **+Add Device** button.



Figure 76: Add a device

2. Choose **LoRaWAN** from the options and click **Next** to proceed.

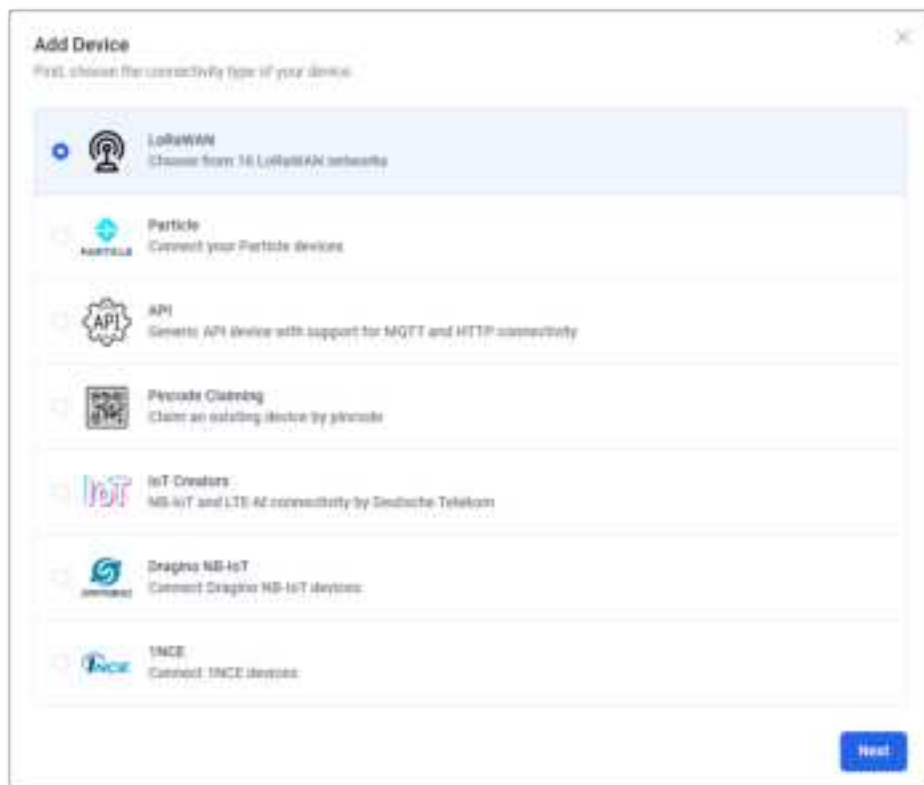

Figure 77: Choose LoRaWAN connectivity

- As the Sensor Hub is a new device, there is no pre-existing template. Create a template by clicking **New Product**, enter the **Product Name**, and click **Next** to proceed.

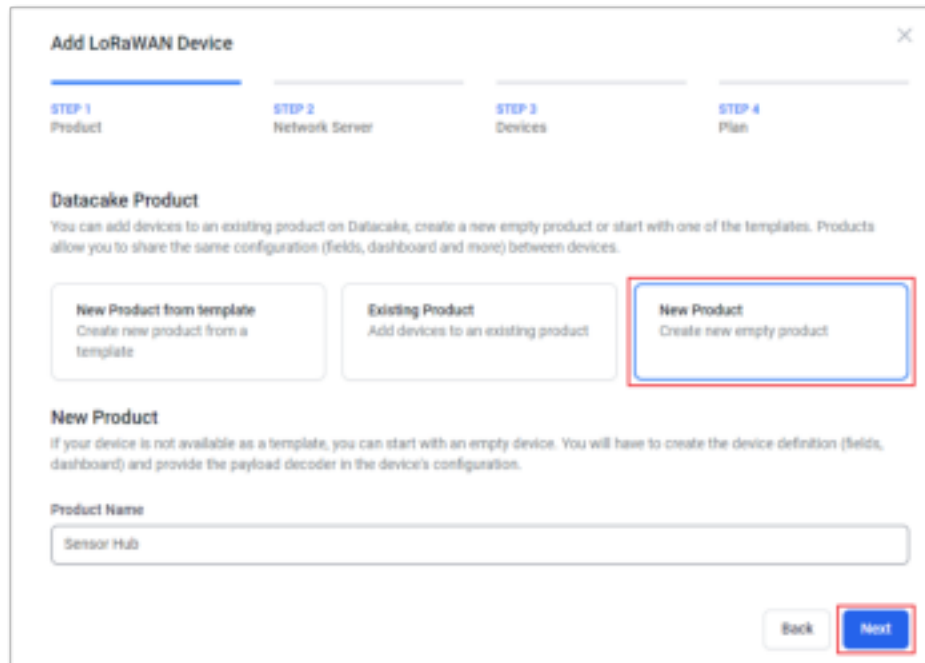

Figure 78: Create a New Product

- Choose a network server for your device. In this guide, select **The Things Stack V3**, then click **Next** to continue.

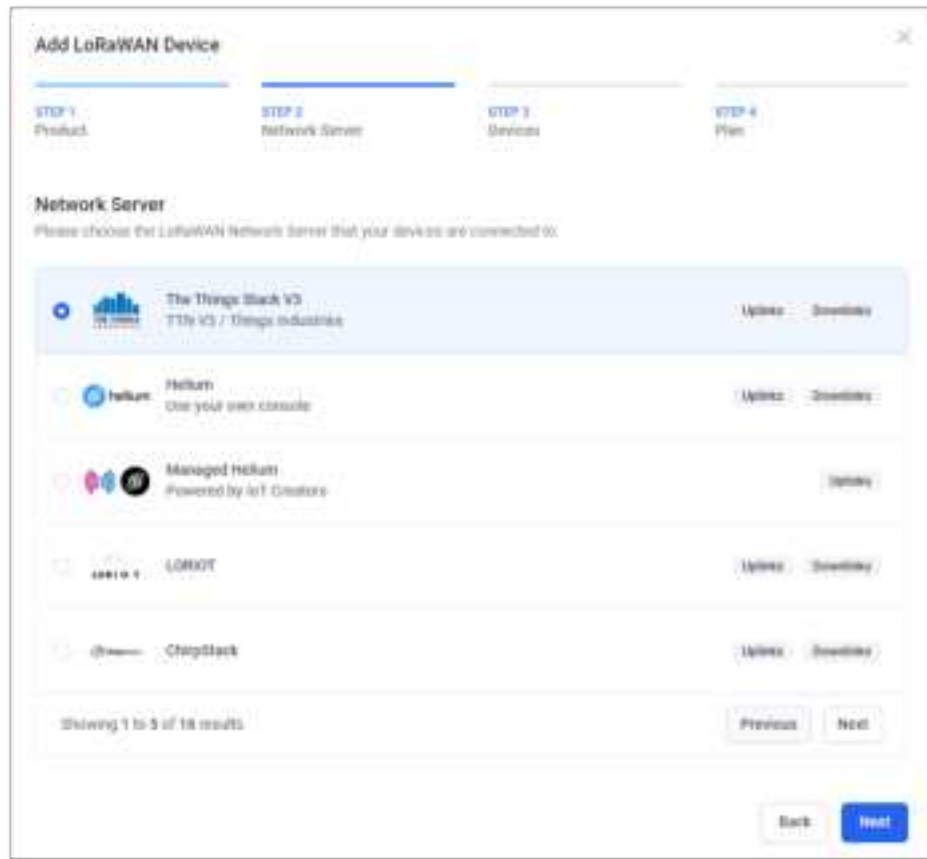

Figure 79: Select the Things Stack V3

- In the **Step 3 Devices** tab, enter the device **DEVEUI** and **NAME** fields, and click **Next** to continue.

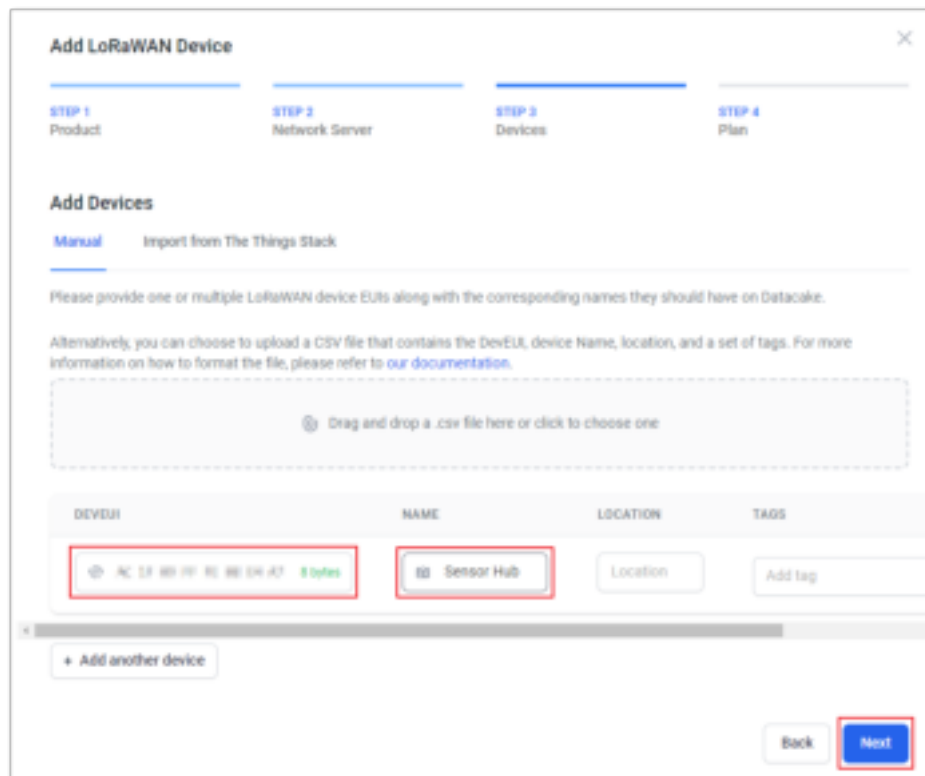

Figure 80: Add DEVEUI and Name

- In **Step 4 Plan**, select the preferred subscription plan, and click **Add 1 device** to add the device. For this example, choose **Free**.

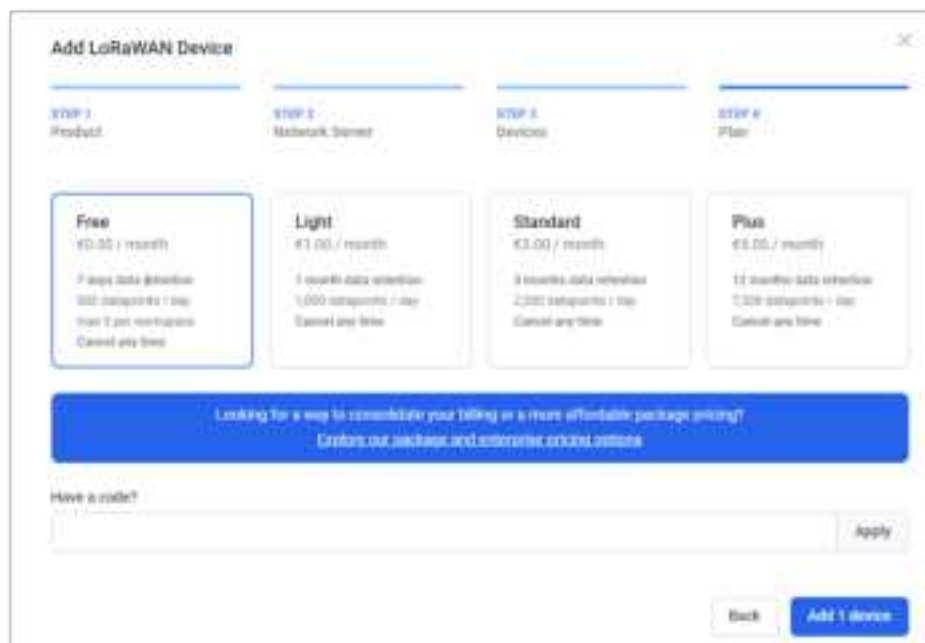

Figure 81: Select a subscription plan

- The registered device can now be viewed on the **Devices** tab.



Figure 82: Registered device

Create a Payload Decoder

1. Click the successfully registered device and go to the **Configuration** tab. Scroll down to the **Payload Decoder** field, then copy and save the decoder code.

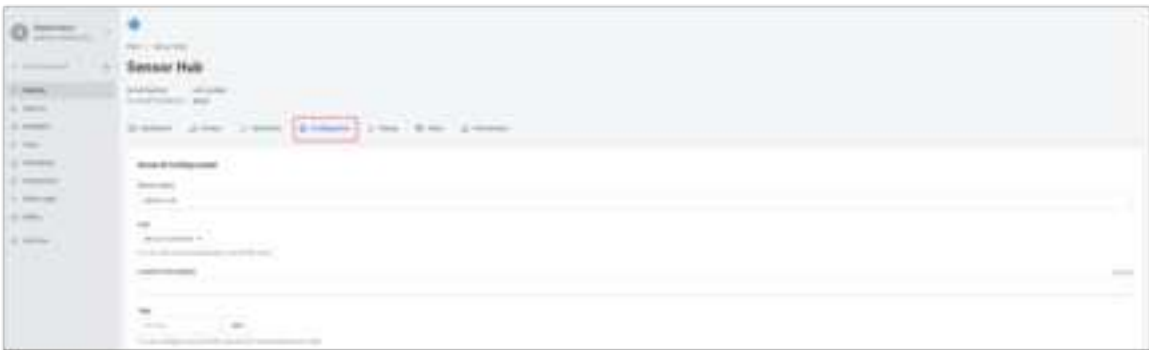

Figure 83: Configuration tab



Figure 84: Decoder code

```
function Decoder(bytes, port) {
  var decoded = {};

  function value(bytes) {
    var value = (bytes[1] << 8) | bytes[0];
    value = twosComplement (value, 16);
  }
}
```

```

return value;
}

var offset = 0;
while (offset < bytes.length ) {
var channel_id = bytes[offset++];
var channel_type = bytes[offset++];
if ( channel_id === 0x01 && channel_type === 0x02) {
var current = (bytes[offset++] * 256 + bytes[offset++]) / 100;
// Measuring ranges: 0-5m, output signal: 4-20mA
    decoded.water_level = (0.3125 * current - 1.25).toFixed (3) ;
} else {
break;
}
}

return decoded;
}

```

2. Displace the menu bar with the **+Add Field** section and click **+Add Field**.



Figure 85: Add field

3. The **Add Field** window appears. Fill out the fields shown in **Figure 85** to configure the stored data in the device.

Figure 86: Configuration fields



NOTE

- Enter an appropriate name in the **Name** field.
- The **Identifier** field will be automatically filled in based on the name.
- When an uplink is received, refresh the page and the **CURRENT VALUE** field will be updated.
- Leave everything else as default and click **Add Field** to complete the setup.

4. When completed, it will look the same, as shown in **Figure 86**.

Name	Identifier	Type	Unit	Current Value	Last Update
Water Level	ANALOG_IN_1	Float	M	0.000	0:00:00

Figure 87: Successfully added fields

Create a Dashboard

1. To create a dashboard, toggle the **edit mode** switch (🔘) on the device **Dashboard** tab.

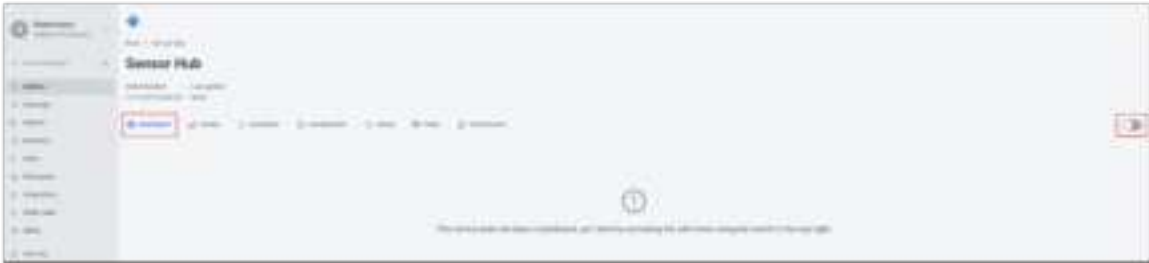

Figure 88: Turn on the edit mode switch

2. Click **+Add Widget** to add a visualization widget.



Figure 89: Add visualization widget

3. Select **Value** from the menu to create a new dashboard.

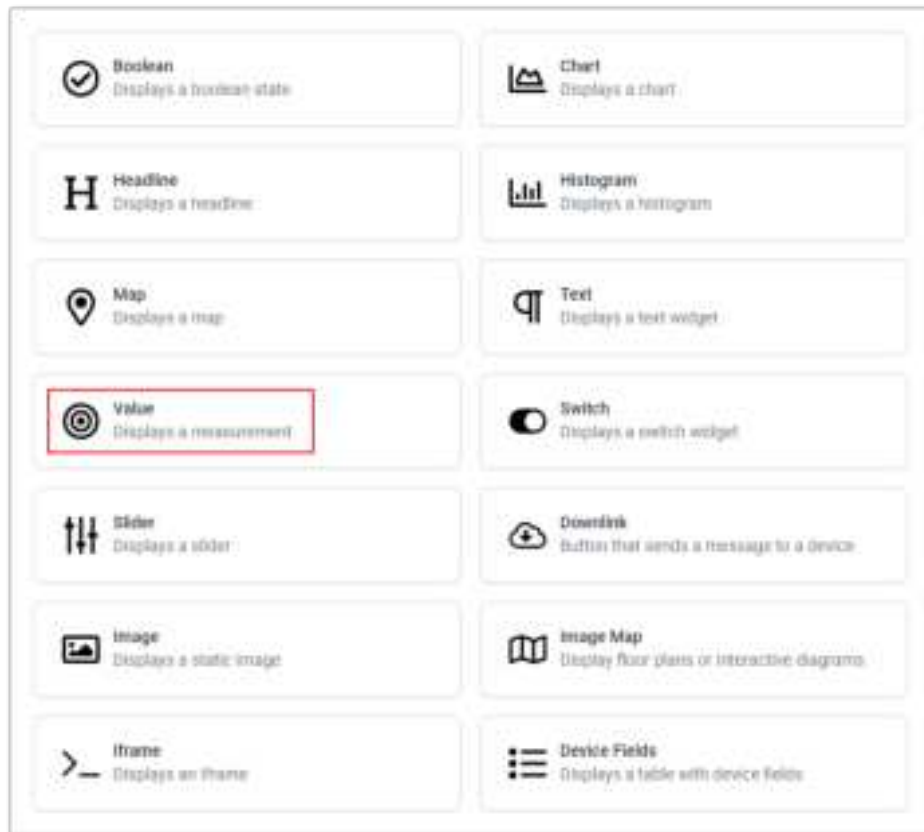

Figure 90: Select **Value** to create a new dashboard



NOTE

You can select different types of widgets to accommodate various data formats.

- In the **Title** field under the **Basics** tab, name the widget as **Water Level**.

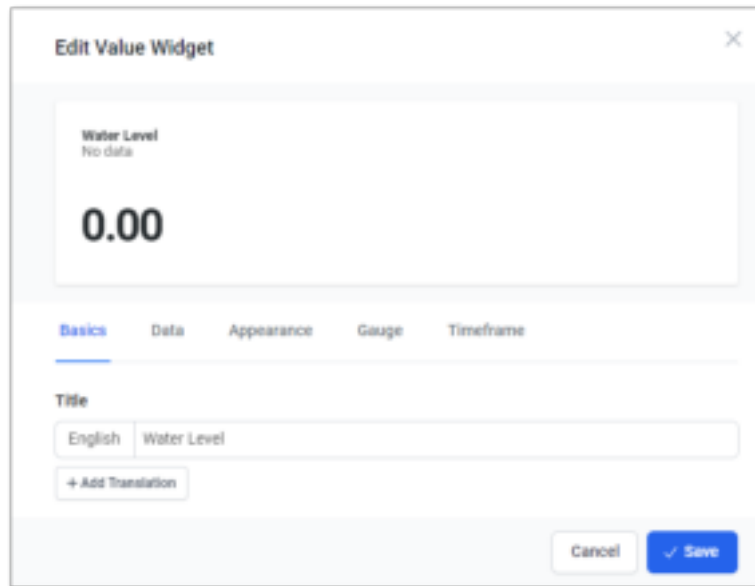

Figure 91: Name the widget

- Under the **Data** tab, click the **Water Level** field and set the unit to **M**.

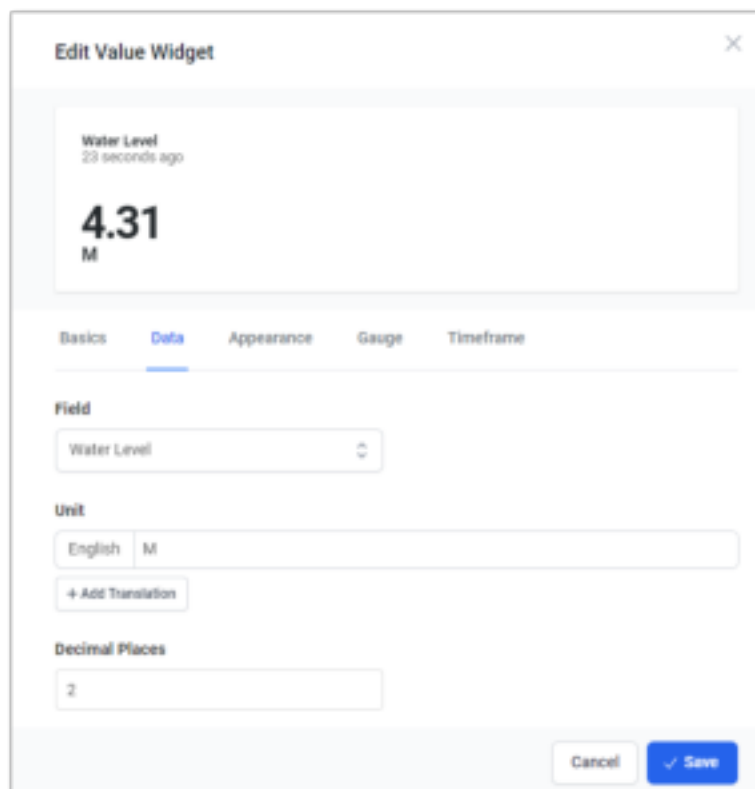

Figure 92: Setting Parameters

- Under the **Gauge** tab, select the gauge type and color, set the range of values for the widget, and then click **Save**.

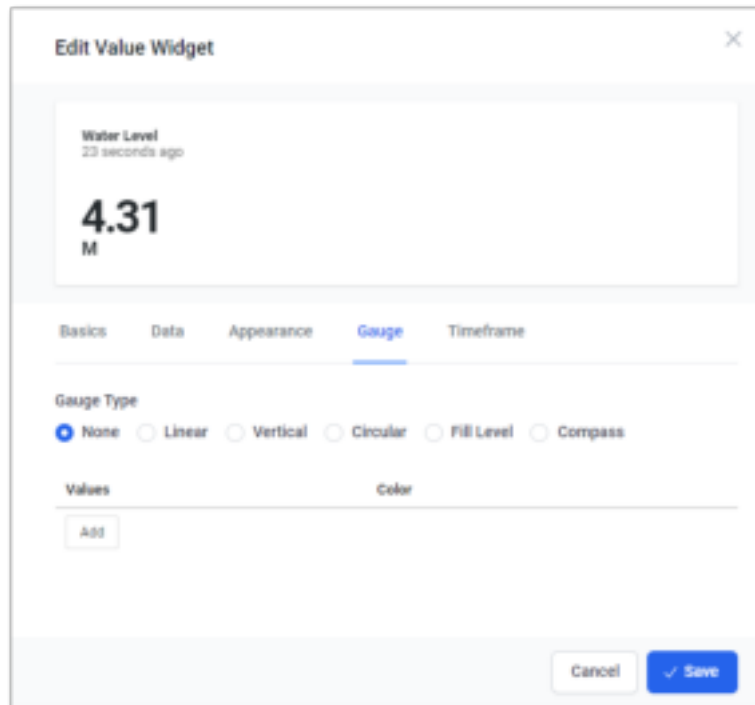

Figure 93: Set Gauge

- When you finish adding the widgets, turn off the **edit mode** switch to save the edits.



Figure 94: Added Widget

6.1.2. Built-In Network Server Setup

The RAK gateway comes with a built-in NS, which eliminates the need to deploy NS in the cloud or locally. This gateway is suitable for small-sized industrial application scenarios and offers various advantages such as cost savings, reduced R&D investment, high execution efficiency, and shorter delays.

The built-in network server of the RAK gateway provides MQTT and HTTP integration that allows for post-processing data and implementing solutions based on the needs.

This section will use the public MQTT broker integration as an example to demonstrate how to use the built-in network server to create a visualization application on ThingsBoard.



Figure 95: Gateway built-in NS application scenario

6.1.2.a. Configure ThingsBoard

1. Log in to [ThingsBoard](#). If you don't have an account yet, [create one](#) before proceeding.

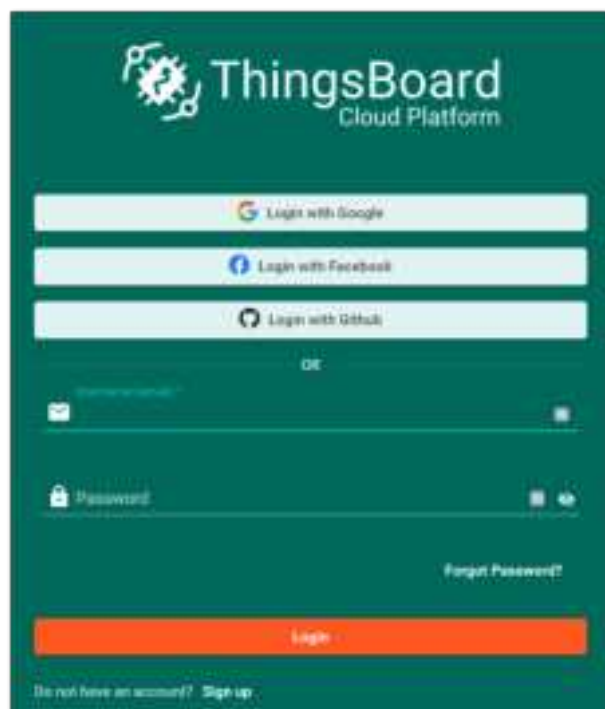

Figure 96: ThingsBoard authentication page

2. After successfully logging in, you will be directed to the ThingsBoard homepage.



Figure 97: ThingsBoard homepage

3. Navigate to the **Integration center > Integration > Data converters** in the left navigation tree to create a data converter for the uplink.



Figure 98: Create a data converter

4. Click the **Add Data Converter** icon (+) and choose the **Create new converter** option.



Figure 99: Create a data converter

5. Enter the name of the decoder in the **Name** field (for example, *Uplink decoder*), leave the **Type** field as **Uplink**, and select the **JavaScript** option.

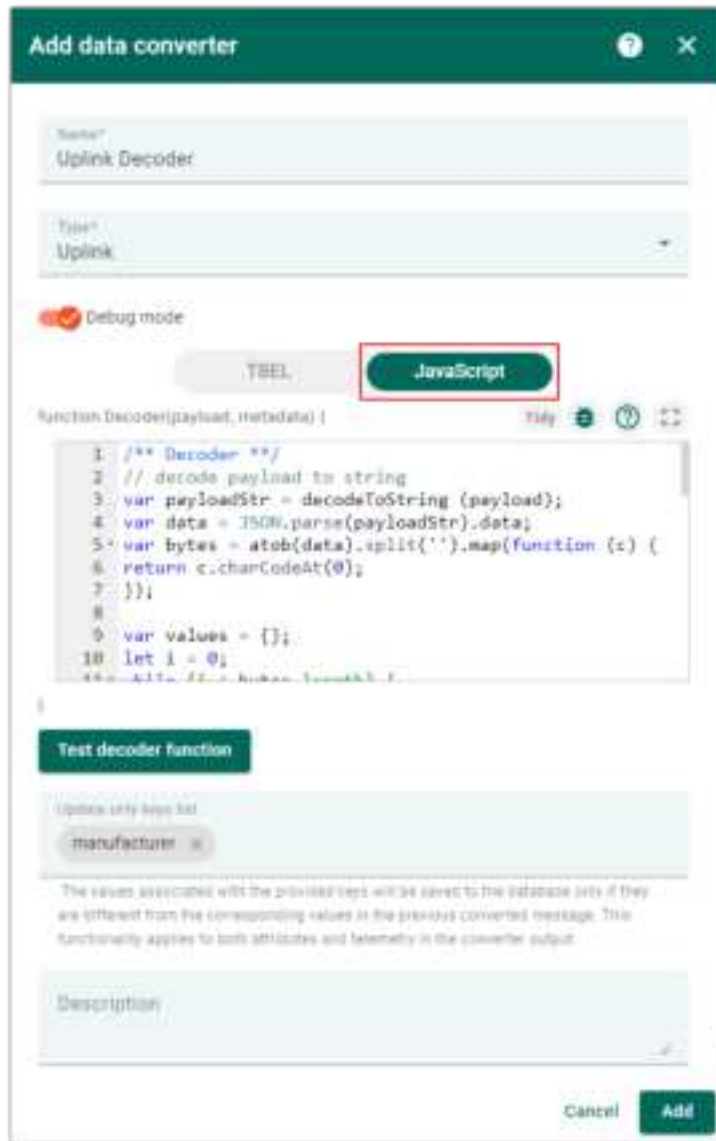

Figure 100: Add the decoder code

6. Edit the decoder code by copying the following code into the edit box. Click **Add** to include the uplink decoder.

```
/** Decoder **/
//decode payload to string
var payloadStr = decodeToString (payload);
var data = JSON.parse ( payloadStr ).data;
var bytes = atob (data).split('').map(function (c) {
return c.charCodeAt (0);
});
```

```

var values = {};
let i = 0;
while ( i < bytes.length ) {
var channelId = (bytes[ i ] << 8) | bytes[ i + 1];
var value = (bytes[ i + 2] * 256 + bytes[ i + 3]) / 100;
i += 4;
switch ( channelId ) {
case 0x0102:
values.waterlevel = (0.3125 * value - 1.25). toFixed (3);
break;
default:
break;
}
}
var integrationName = 'MQTT Integration';
var deviceName = ' water_level ';
var result = {
deviceName : deviceName ,
attributes: {
integrationName : metadata[' integrationName '],
waterlevel : values.waterlevel ,
},
};

/** Helper functions **/

function decodeToString (payload) {
return String.fromCharCode.apply (String, payload);
}

return result;

```

7. Navigate to the **Integration Center > Integrations** menu and click the **Add Integration** icon (+) to add the MQTT integration.



Figure 101: Add the MQTT integration

- Enter the name of the integration (for example, *MQTT Integration*) in the **Name** field and select **MQTT** in the Type drop-down menu. Click **Next** to continue.

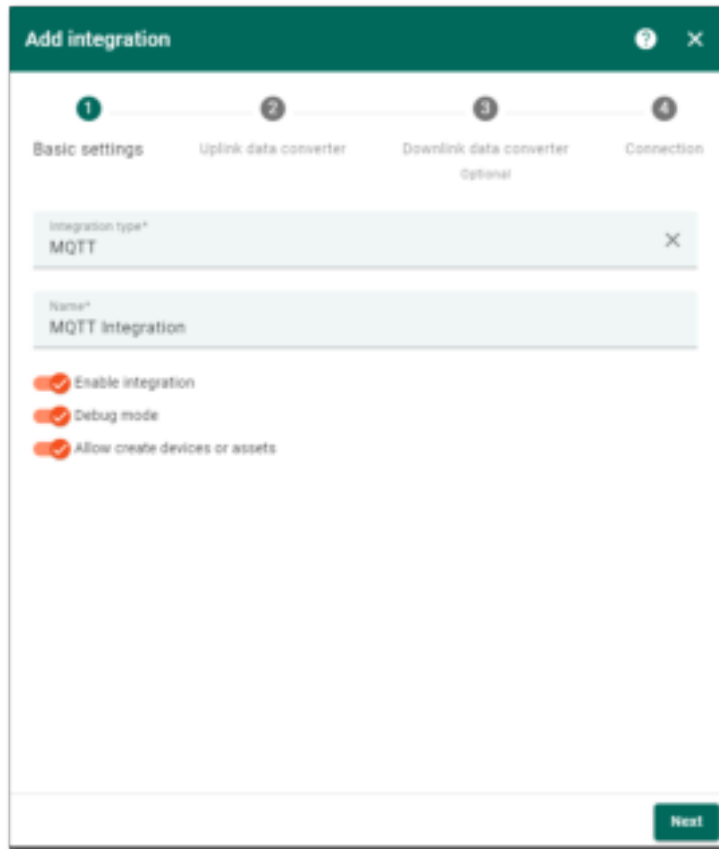

Figure 102: Fill in the integration name

- In the **Uplink data converter** options, click **Select existing** to choose the previously created decoder (**Uplink Decoder**), then click **Next**.

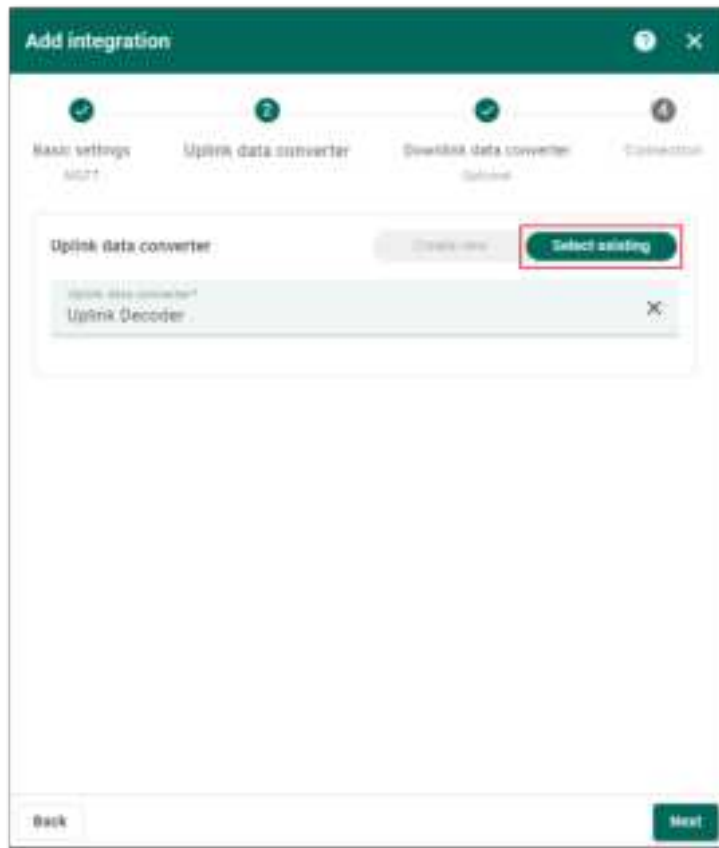

Figure 103: Select the created decoder

10. In the **Downlink data converter** interface, no configuration is necessary. Simply click **Skip** to bypass this setup.
11. Configure connection options. **Host** is the MQTT broker address used for messages. The Host of the external MQTT broker used in this example is *broker.hivemq.com*. You can choose to use other brokers with a different Host.
12. Enter the address *broker.hivemq.com* in the **Host** field, with the port number 1883. Click the **Add topic filter** button to configure the subscription topic:

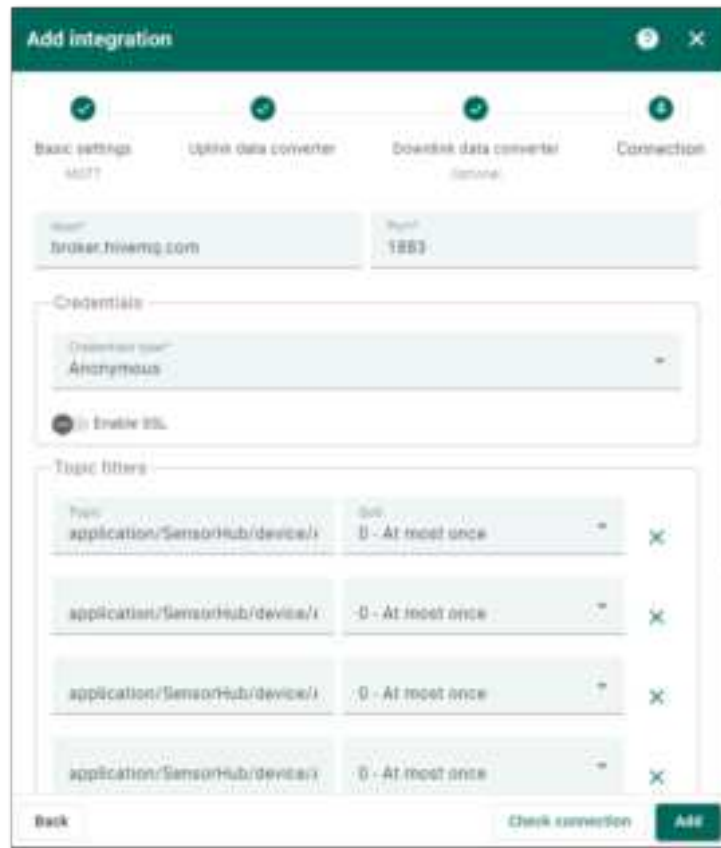

Figure 104: Configure the connection options

Configure the subscription topic

```

application/{{application_name}}/device/{{device_EUI}}/join
application/{{application_name}}/device/{{device_EUI}}/rx
application/{{application_name}}/device/{{device_EUI}}/tx
application/{{application_name}}/device/{{device_EUI}}/ack
application/{{application_name}}/device/{{device_EUI}}/status
  
```

- **application_name**: the application ID created in the gateway.
- **device_EUI**: the device EUI of the end device.

13. Modify the parameter values corresponding to the topics based on the actual application created and the device used.



NOTE

The values in the subscription topic must be all lowercase. For example, `application/1/device/0123456789abcdef/join`.

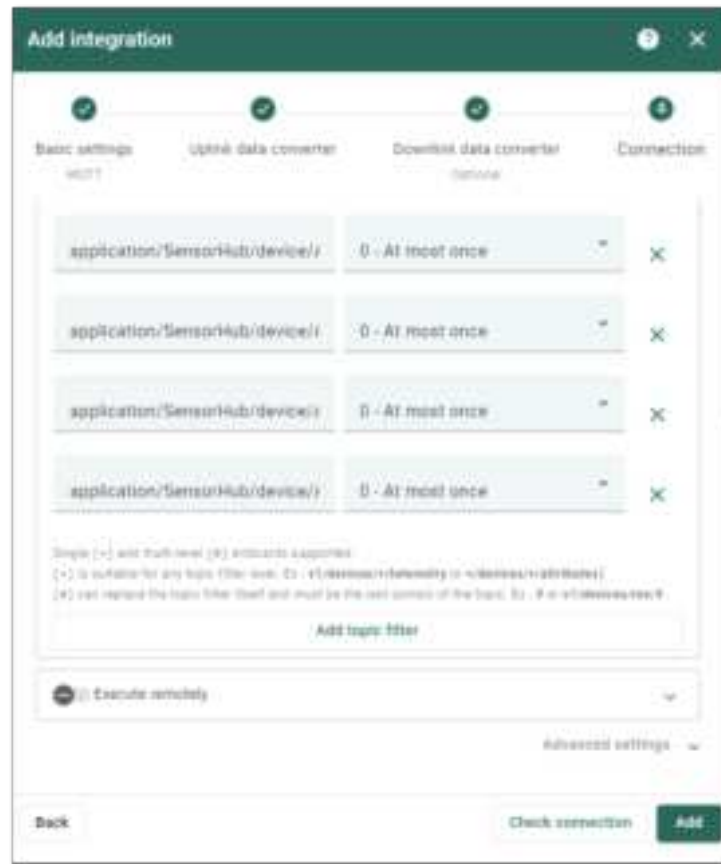

Figure 105: Add Integration

14. After configuring the details, click the **Add** button to save and complete the settings.

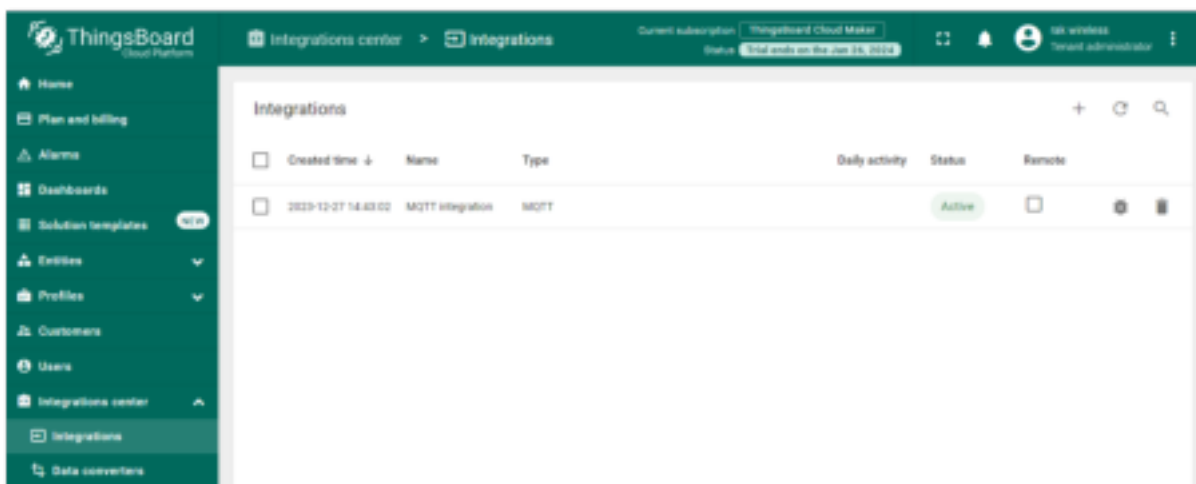

Figure 106: Configuration completed

6.1.2.b. Configure Gateway

This section will use the [RAK7268V2 WisGate Edge Lite 2](#) as an example.

1. To access the gateway web management platform, refer to the [WisGateOS V2 user manual](#) for details.



Figure 107: WisGate OS Web UI

2. After successfully logging in, navigate to the **LoRa®** menu in the left navigation tree and set the **Work mode** of the gateway to **Built-in network server**.

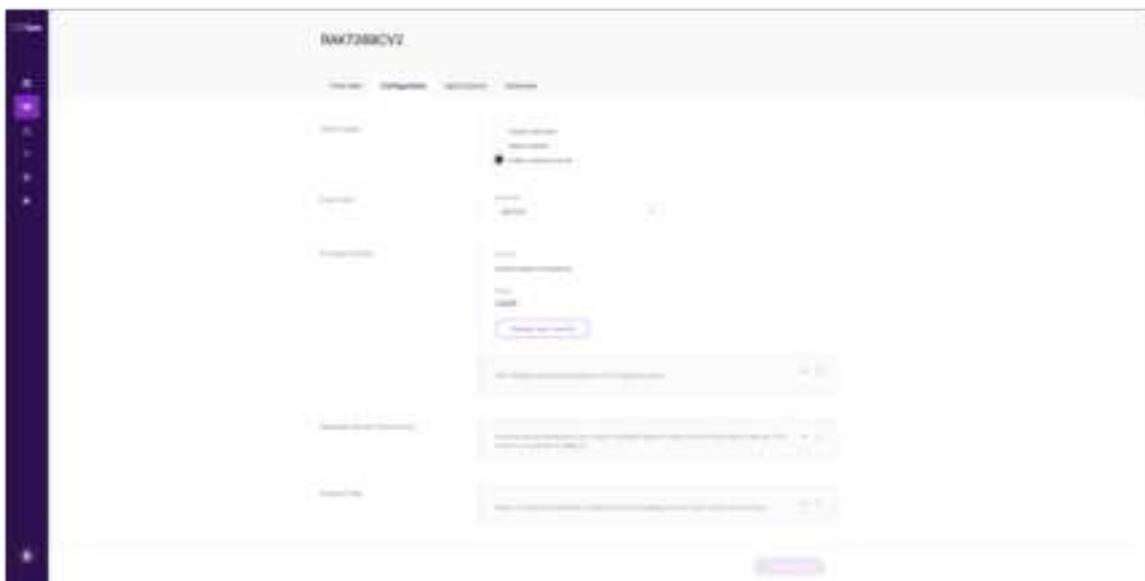

Figure 108: Set the Work mode of the gateway

3. Once done with the setting, click the **Applications** tab, then the **Add application** button. You can also click **add one now** text link to add a new application.



Figure 109: Applications tab

4. Configure the following information: **Application name**, **Application Description**, and **Application Type**.
 - **Unified Application Key:** Choose this option if all devices will use the same application key. Once selected, a field for the application key appears, where you can manually type in an application key or click the **Autogenerate** button to generate one.

Figure 110: Unified Application Key

- After enabling the **Auto Add Device** option, configure the **Application EUI option**. The value needs to be consistent with the node value. Once you have verified the application EUI and key, the device will be added automatically to the application.

Figure 111: Auto Add Device

NOTE

You can obtain the values by either querying the end device or generating it automatically and modifying the corresponding value of the device synchronously.

- **Separate Application keys:** Each device has its own application key. Add the key when registering the device.

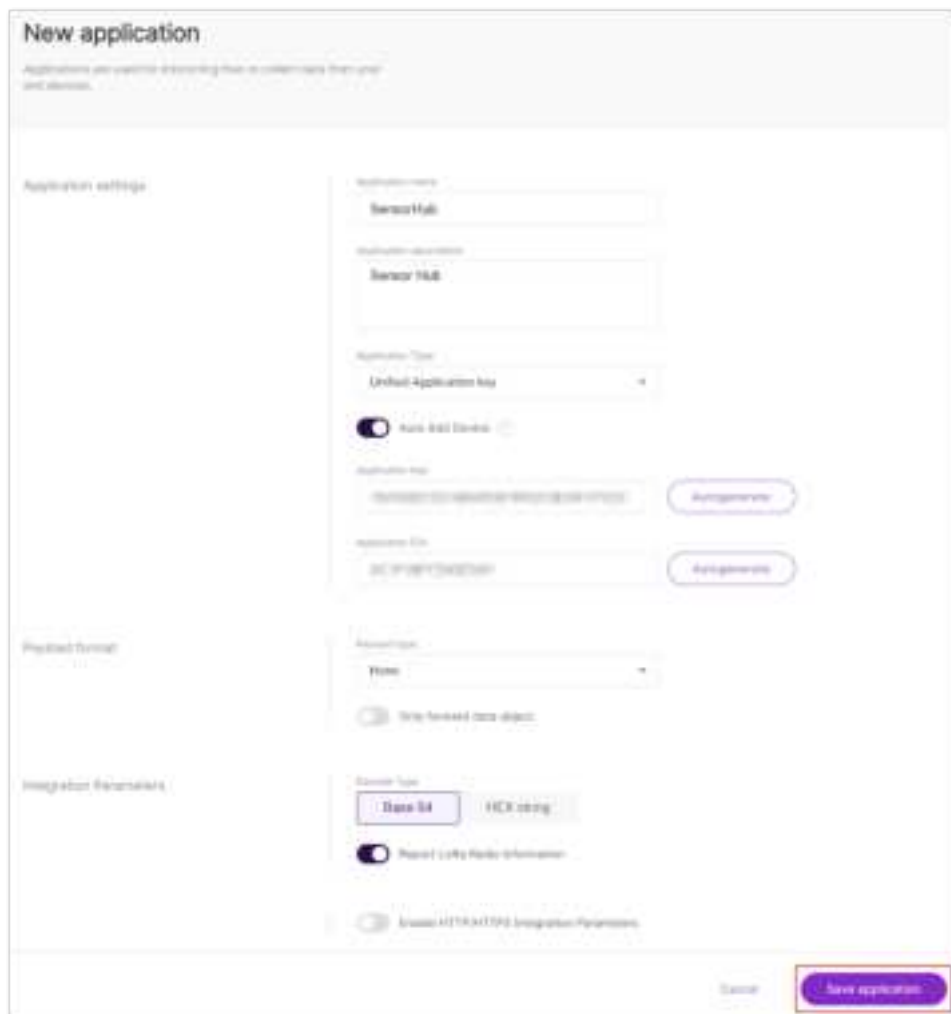

Figure 112: Add Application Key

5. Once you've completed the configuration, click on **Save Application** to add the new application.
6. In the application list, locate the newly created application and navigate to the **End devices** tab. If you've enabled the **Auto Add Device** function, the device will be automatically registered upon the addition request.

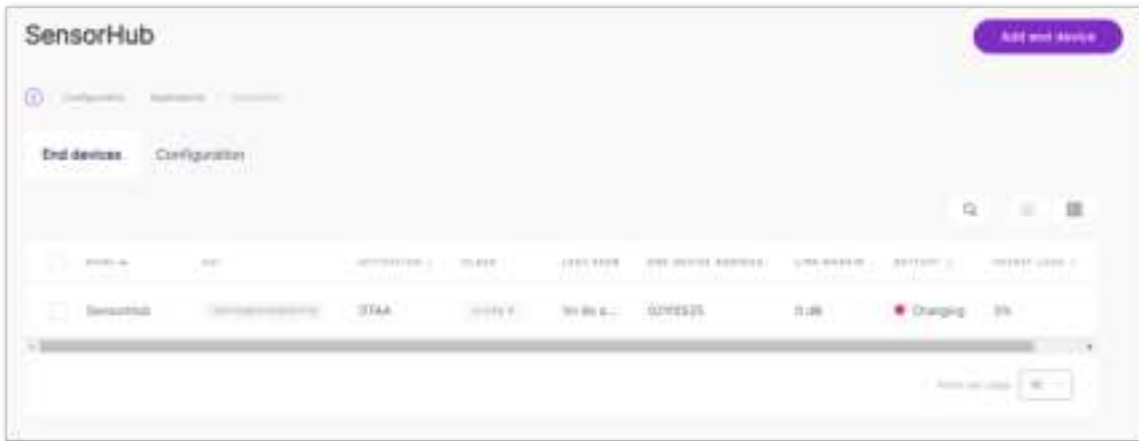

Figure 113: End devices tab

7. Click the **Add end device** button. In the **End device information** interface, fill in the following information:

- **Activation Mode:** Select the device's activation mode: OTAA or ABP.
 - Choosing ABP mode creates two additional fields: **Application Session Key** and **Network Session Key**.
 - In this example, use OTAA activation mode.
- **End device (group) name:** Enter the name of the end device or the group it belongs to.
- **End device description (optional):** Optionally provide a description for the end device.
- **Class:** Select **Class A** for the device's operating mode.
- **Frame Counter Width:** Keep the default value.
- **LoRaWAN MAC Version:** The protocol version (V1.0.3) of the node.

Figure 114: Add new end devices

8. After completing, click **Add end devices** to proceed to the next step.

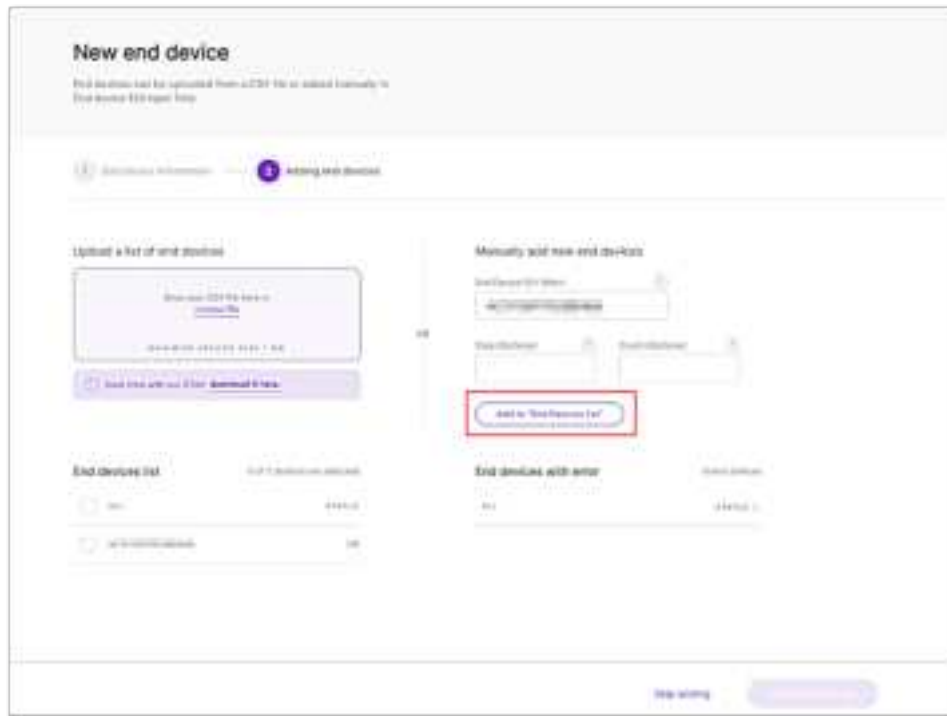

Figure 115: Add the device to the device list

- In the **Adding end devices** interface, enter the device EUI in the **End Device EUI (main)** field and click the **Add to End Devices list** button. Then click **Add end devices** to complete adding the end device.



NOTE

- The device EUI configured here must match the end device. You can either obtain it by querying the end device or entering one (1) EUI and synchronously updating the corresponding value of the end device.
- If the EUI is correct, the device will appear in the End devices list.
- If the EUI is incorrect, the device will be displayed in the End devices with an error section.

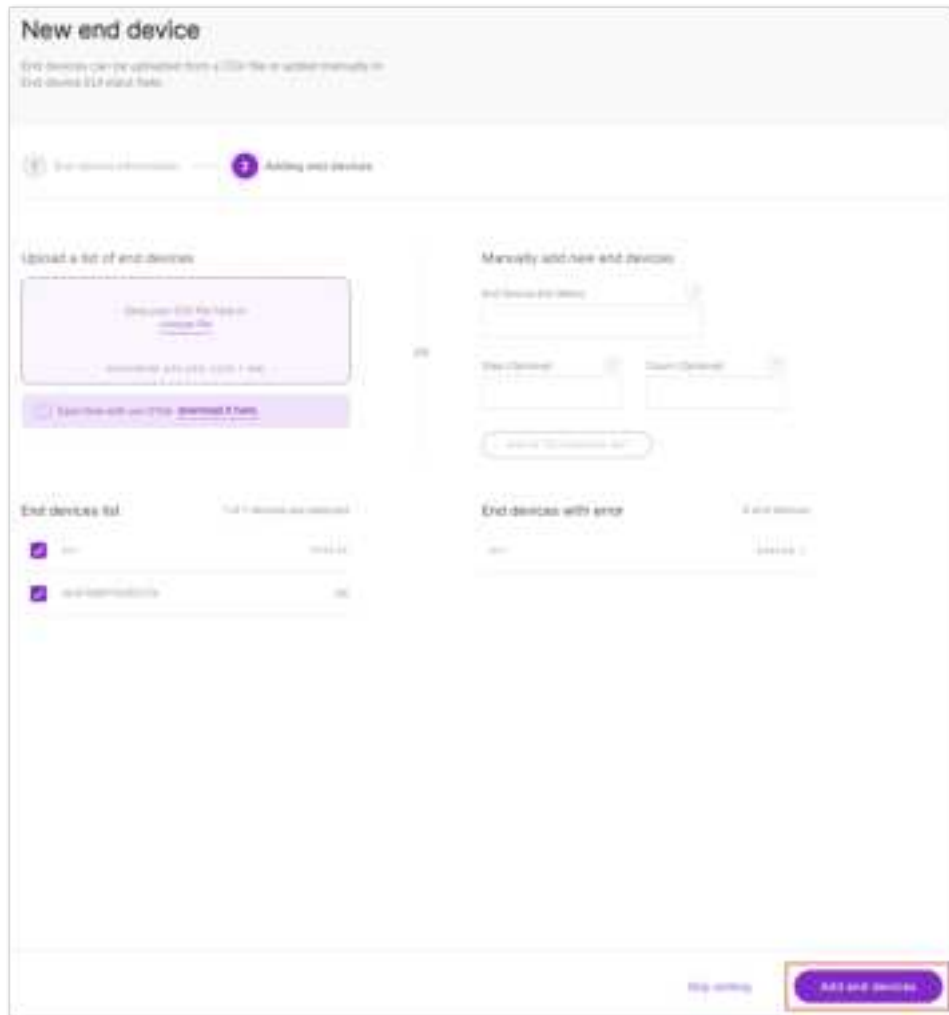

Figure 116: Complete the end device addition

10. Click the **Add** button to confirm adding the device.

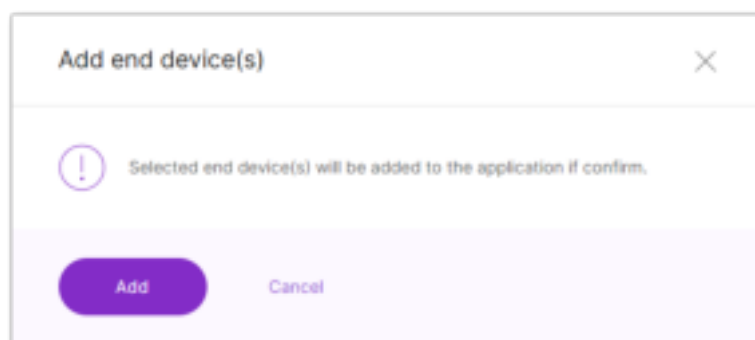

Figure 117: Confirm to add the end device

11. When finished, enter the **End devices** interface, where you can see the created end device.

6.1.2.c. Connect Sensor Hub to Built-In Network Server

For specific configuration on how to connect Sensor Hub to the server, refer to **Sensor Hub Network Configuration > LoRaWAN Application Scenario**.

Once completed, the device will join the network. As shown in **Figure 118**, the end device **SensorHub** has successfully connected to the gateway's built-in server.

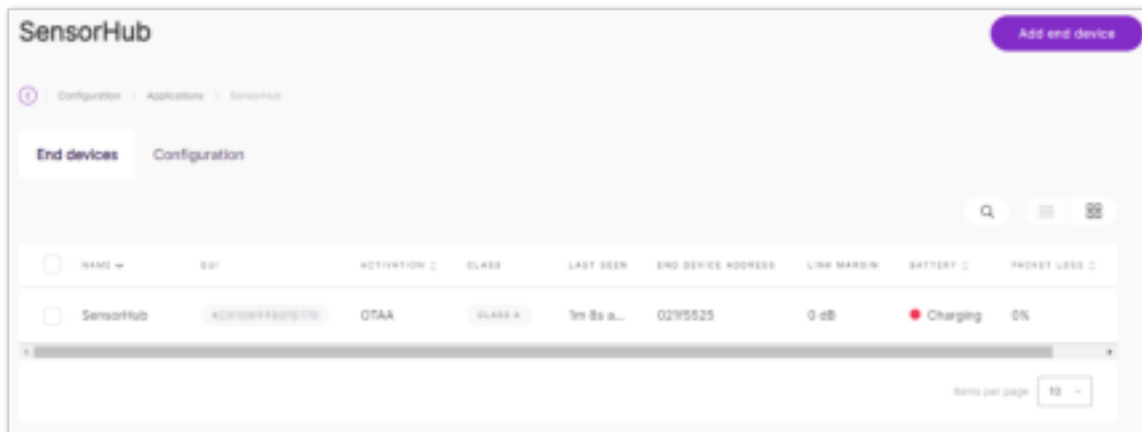

Figure 118: End device has been connected

6.1.2.d. Configure MQTT Integration

1. Navigate to the **LoRa® > Configuration > Integration Interface Parameters** section.
2. Toggle the **Enable Integration Interface** option and select **Generic MQTT** as the **Integration mode**.

Configure the integration interface to forward all received data to an external network server.

Enable Integration Interface

Integration mode

Generic MQTT AWS IoT Core

MQTT Broker Address

MQTT Broker Port MQTT Version

QoS Keepalive Interval (s)

Clean session Retain

Client ID

Enable User Authentication

SSL/TLS Mode

Join Topic

Uplink Topic

Downlink Topic

Downlink Acknowledge Topic

Figure 119: Set up MQTT integration

3. In the **MQTT Broker Address** option, enter `broker.hivemq.com`, then click **Save changes**.
4. After the device has joined and has been sending uplink data, check the

uplink data in **ThingsBoard > Integrations > Your Integration > Events**.

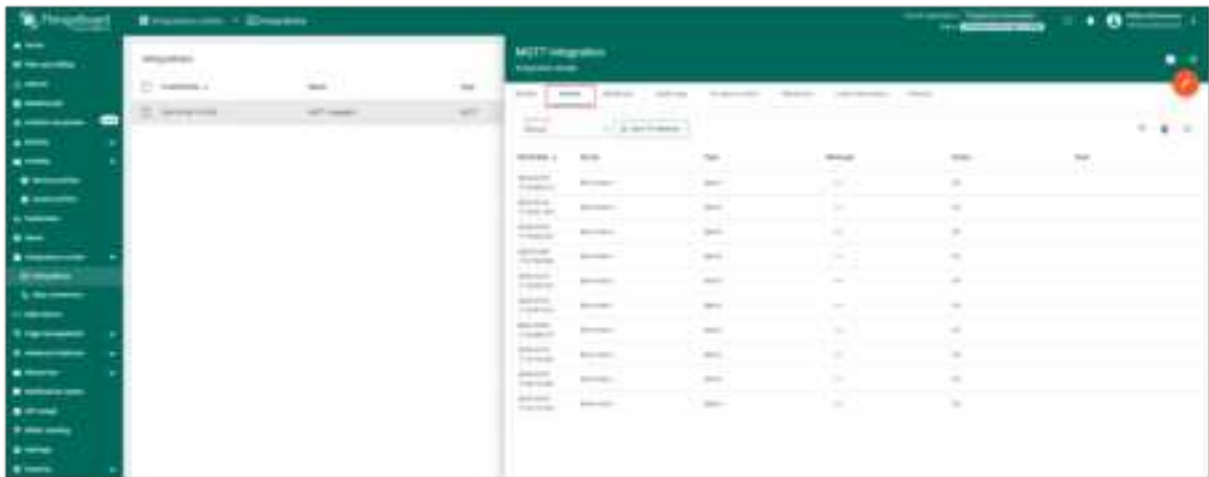

Figure 120: View the gateway uplink data

6.1.2.e. Visualize Data Through ThingsBoard

1. After creating the data converter, integrating, and obtaining some data in the **Event** tab, check the automatically created devices based on the decoder in the **Entities > Devices > Groups** tab.



Figure 121: Check the device

2. Click the group named **All** in the **Device groups** menu to automatically create a decoder device.



Figure 122: Automatically created decoder device

3. Click the device, navigate to the **Attributes** tab, and check on the node data.



Figure 123: Node data

4. To visualize the data, simply select the values you wish to display, then click the **Show on widget** button.
5. On the next page, select the desired widget for the data from the **Current bundle** drop-down menu. In this example, choose **Tables**.



Figure 124: Select Widget

6. After selecting the widget, click **Add to dashboard** to proceed. By default, the profile does not have a dashboard, so you need to select Create new dashboard and enter a name for the dashboard in the New dashboard title field.

- In this guide, name the dashboard **SensorHub_Waterlevel**.



Figure 125: Enter the dashboard name

7. After setting the dashboard name, click the **Add** button to add more widgets. Alternatively, check the **Open dashboard** option to automatically open the created dashboard after adding the widget.

NOTE

If the **Open** dashboard option is not selected, users can still easily view the added widgets via **Dashboard groups > All > [Group Name]**.



Figure 126: Dashboard created

6.2. NB-IoT/LTE CAT-M1 Application

6.2.1. Connect Sensor Hub to MQTT Server

In the **Network Server and Visualization Configuration** section, the server in the example has been set as a public MQTT broker: *broker.hivemq.com*. You can also choose other brokers or servers, such as AWS IoT Core (optional), according to actual usage scenarios.



Figure 127: NB-IoT/LTE CAT-M1 application scenario

6.2.2. Visualize Data Through Datacake

In this example, you will use Datacake as the visualization platform. Datacake is a versatile IoT platform designed to visualize data from nodes in a user-friendly manner.

To get started, create an account on the [official website](#) and log in.

6.2.2.a. Add SensorHub to Datacake

1. After logging in to your account, navigate to the **Devices** tab and click **+** **Add Device** to proceed with adding the Sensor Hub end device.



Figure 128: Devices page

2. Select the **API** option and click **Next** to proceed.

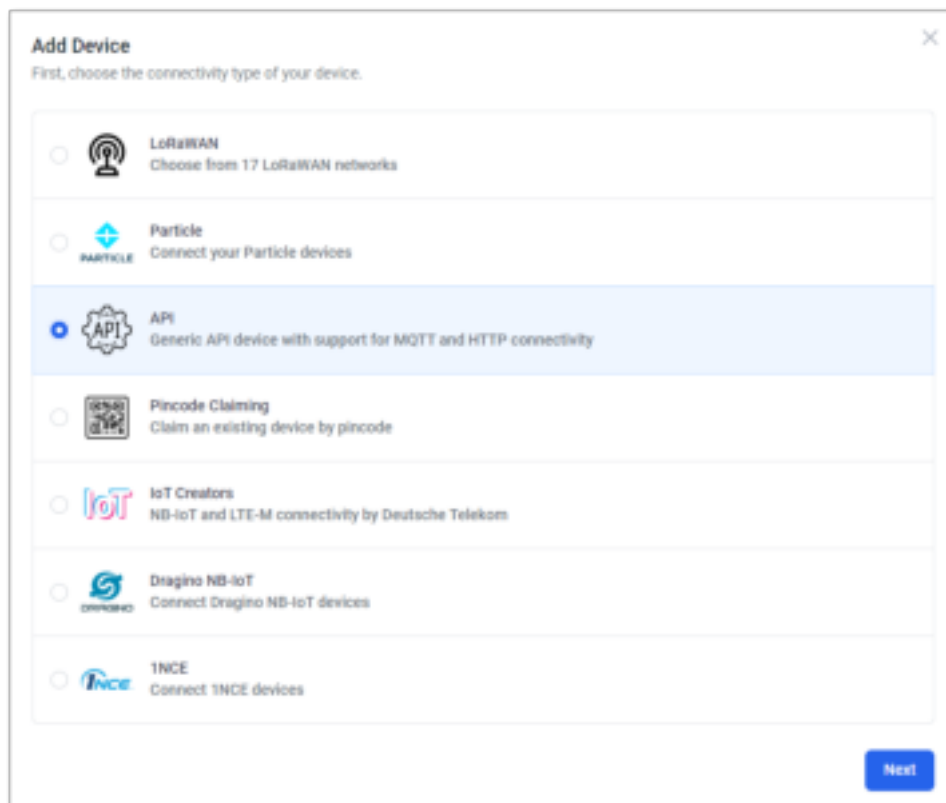

Figure 129: Select API

3. As the device is new and there's no ready-made template, choose **New Product** from the **Datacake Product** options. Enter the device name in the **Product Name** field, then click **Next** to proceed.

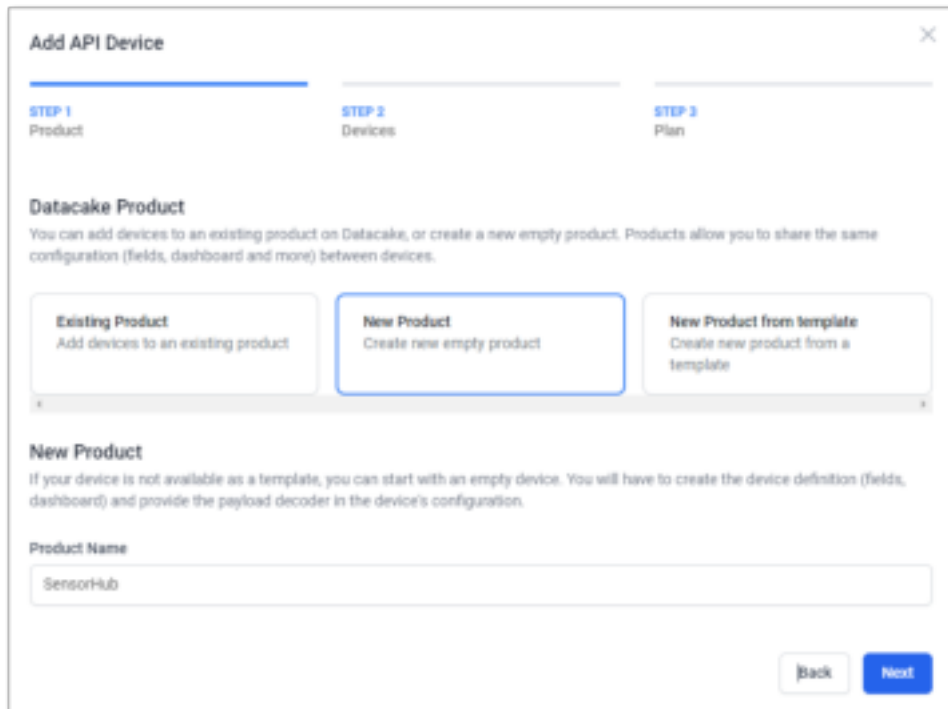

Figure 130: Select New Product

- The **SERIAL NUMBER** field can be left blank. Datacake will randomly generate a serial number for the device, then click **Next**.



Figure 131: Add Devices

- Select the preferred subscription plan, then click **Add 1 device**. For this example, choose **Free**.

2. Scroll down to the **API Configuration** option and copy the **Serial number**. Save it locally for later use.



Figure 135: Copy the serial number

3. Continue scrolling down to the **MQTT Configuration** option and configure the external MQTT Broker.
4. Click **+Add new MQTT server** and configure the relevant parameters.



Figure 136: Configure the external MQTT Broker

5. Fill in the relevant information based on the actual server used, then click **Test Connection** to verify whether Datacake can successfully connect to the **MQTT Broker**.

Figure 137: Configure the external MQTT Broker



NOTE

If SSL/TLS encryption and authentication are set for more secure communication, ensure to configure them accordingly in this section. However, for this example, you can skip this option.

6. If the connection is successful, you will see the message **Connection successful**. Click **Add MQTT Server** to complete the addition of the MQTT server.



Figure 138: Connection established successfully

7. After successfully adding the MQTT server, click on **+Add Uplink Decoder** to add a decoder.



Figure 139: Add MQTT Server

8. A new window will appear and fill in the fields according to your project.



Figure 140: Add Uplink Decoder

- Subscribe to topics:** Configure the subscription topics, that is, the value of the **Publish Topic** configured in the **Network Server and Visualization Configuration** section.

- **Decoder function:** Copy the following decoding code and paste it into the **Decoder function** space.

```
function Decoder(topic, payload) {
  var decoded = [];
  var data = JSON.parse ( payload .replace (/\\s*/g, "" ) );
  for (var key in data) {
    decoded. push (
      {
        device: "cfdac42a-b7ac-4a94-ab77-fb5090150aa6",
        field: key,
        value: data[key]
      }
    )
  }
  return decoded;
}
```



NOTE

In the above code, make sure that the parameter **serial_number** (device: cfdac42a-b7ac-4a94-ab77-fb5090150aa6) matches the serial number saved locally earlier.

9. Once completed, click **Add uplink decoder**.
10. In the **Fields** option, click **+Add Field** to show the monitoring values of the devices. Each device can create a certain number of fields, also known as **data points**.



Figure 141: Add Field

11. Set the necessary parameters of the Fields. For **Fields** with multiple data points, add them one by one. Once done, click **Add Field**.

Add Field ✕

Fields define the schema of the data the device stores.

Type

Float

Name

Water Level

Identifier

ANALOG_IN_1

The field identifier is a unique string that can consist of uppercase letters, numbers and underscores. Once a field has been created, the identifier can not be changed.

Unit Optional

M

Role

None

You can define the role of a field, which are unique per product and can be used to add context to global visualisations and reports.

Formula Optional

Formulas can be used to perform calculations on values from other fields. Fields that have a formula can not be written to from a decoder or via the API.

Use Formula

Cancel Add Field

Figure 142: Set the related parameters of the field



NOTE

The **Identifier** field will be automatically filled based on the name.

12. Once the uplink data is received, the **Current value** column in the **Fields** list will display the current monitoring value from the sensor.

Name	Identifier	Type	Unit	Current Value	Last Update
Water Level	ANALOG_IN_1	Float	M	0.000	2020-08-01 10:00:00

Figure 143: Added sensor monitoring values

6.2.2.c. Create a Dashboard to Visualize Data

Dashboards can be customized depending on the specific needs and preferences of a project. Follow the steps below to add widgets and visualize the data.

1. On the device details page, navigate to the **Dashboard** tab, then toggle on the edit mode switch (🔧).
2. Click on the **+ Add Widget** button to add a widget for visualizing data.



Figure 144: Open the edit mode

3. Choose what type of widgets you want to display. For this example, select **Value**.

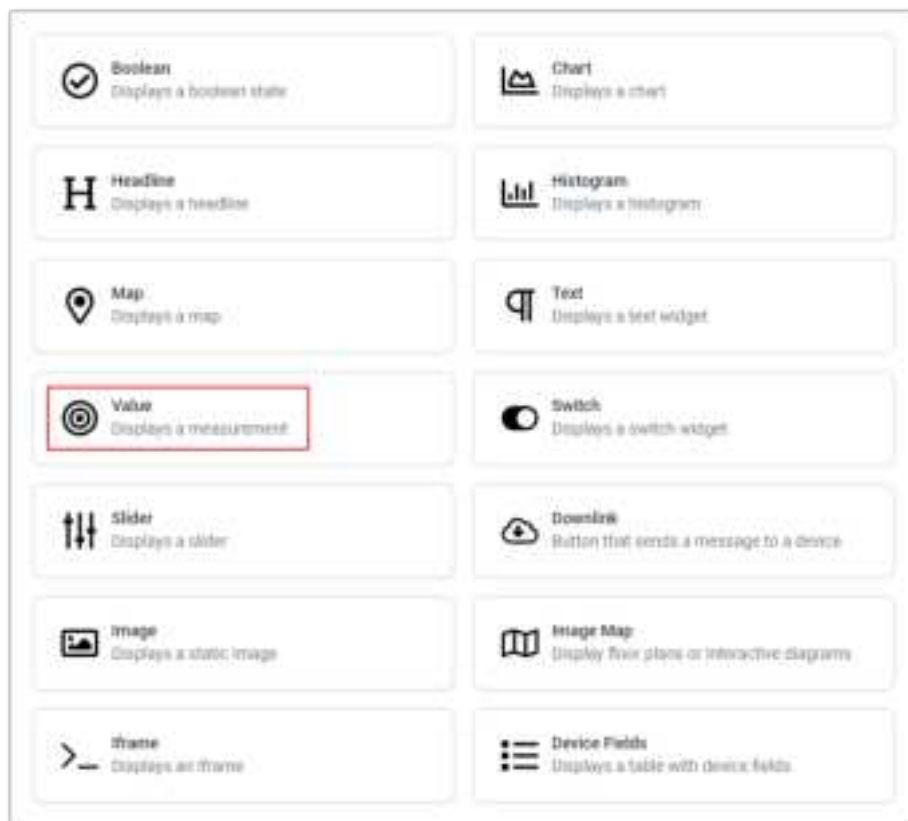

Figure 145: Select and add widgets for visualizing data

- Go to the **Data** tab and choose the data you want to visualize from the available **Field** options. For this example, select **Water Level** and set the unit to **m**.

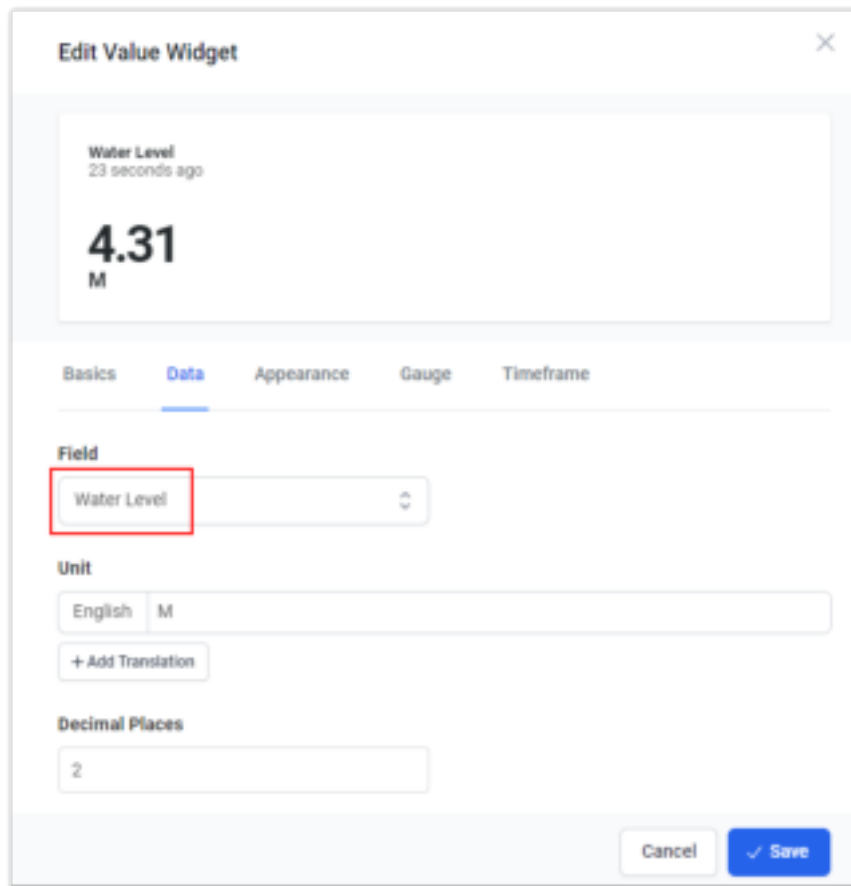

Figure 146: Select the visualization data field

- After configuring the widget, click **Save**. You should now see the successfully created water level widget on the Dashboard interface.
- Once done with the dashboard configuration, turn off the **edit mode** switch (🔒) to save the settings.



Figure 147: Close edit mode to save the settings