



User's Manual

**XSA 1000**  
**XSA 1000 BLACK**



## **XSA 1000 / XSA 1000 BLACK**

### **Universal Support**

Congratulations, you just have purchased a product with Intelbras quality and safety.

The XSA 1000 / XSA 1000 BLACK universal support was structured to fit perfectly in most presence sensors available in the market and other equipments with compatible features, and also have a wide direction angle, support to wiring passage and UV protection for installing in outdoor environments.

## Caution and safety

---

- » LGPD – Data processing by Intelbras: Intelbras does not access, transfer, capture or perform any type of processing of personal data from this product.
- » Follow all instructions in the manual for assembling and installing the product;
- » Make sure that both the sensor and the bracket are securely fixed in place to avoid changes in the detection angle of the product.
- » Make sure the installation location is stable and not subject to flickering.
- » We recommend that the installation be carried out by a professional installer as incorrect use of the articulator may impair the PET function and the coverage angle of the presence sensor.

# Summary

1. Technical specifications	5
2. Product	5
3. Features	6
4. Installation	6
Term of Warranty	10

# 1. Technical specifications

## General features

Material	Plastic with UV protection
Weight	44 g
Load capacity	1.5 kg
Installation environment	Internal / external
Size (W × H × D)	99 × 58 × 64 mm
Horizontal movement angle	160°
Vertical movement angle	160°

## 2. Product

### Components

1	Axle
2	Cover
3	Ring
4	Base
5	Upper base
6	Connector
7	Screw 3.5 × 9.5 mm

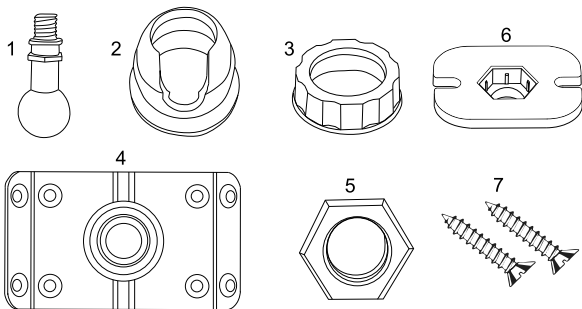

Mounted support

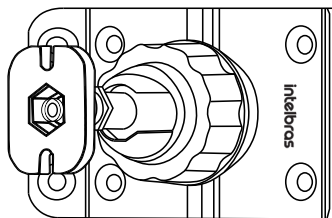

Mounted support

### 3. Features

---

- » Made of UV protected material;
- » Easy to install;
- » Wide application scenario;
- » Compatible with most presence sensors available in the market and other equipments for the same applications and purpose.

### 4. Installation

---

- » Insert the shaft into the cover (part 1 and part 2);
- » Pass the ring through the previous set (piece 3);
- » Insert the nut into the connector (key 5 and 6);

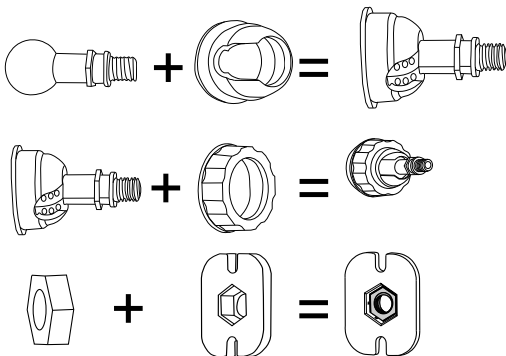

- » Screw the ring on the base turning clockwise until you feel that it is tight;

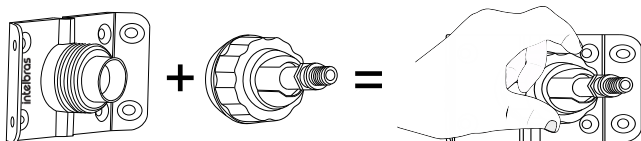

- » Insert the nut into the connector parts 5 and 6.

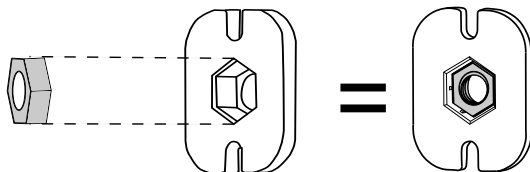

- » Attach the support to the base of the sensor or product to be used as shown in the image below, use the fixing screws that come with the XSA 1000 support, then insert the shaft through the hole, rotating clockwise until you feel that it is stuck.

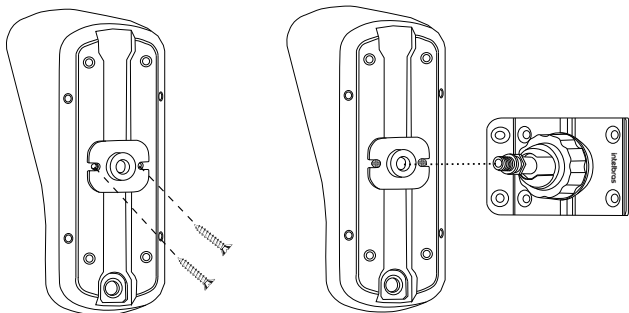

To fix the XAS 1000 in the installation location, follow the steps below:

**Note:** the XAS 1000 support has an opening for passing the wire if necessary, follow the steps below for its correct use.

- » Lead the wiring through the wire feedthrough;
- » Fix the wire through the two internal locks for fixing the wiring;
- » Route the wire through the hole in the center of the base towards the inside of the product to be fixed.

**Note:** It is important to use the locks for fixing the wiring, as they prevent water from entering the inside of the sensor conducted by the wiring.

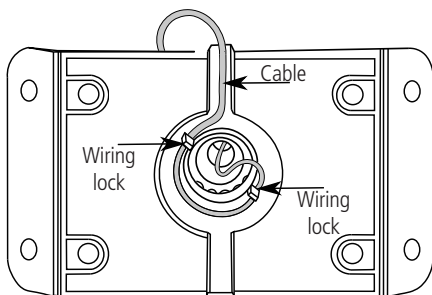

Wired base rear view

- » If the sensor is installed on a flat surface, use the four innermost holes in the base for mounting. If the sensor is used on a 90° corner, use the four outermost screws on the base.

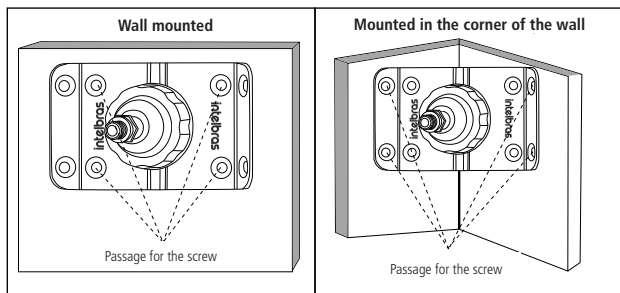



- » After definitively fixing the base, direct the sensor to the desired detection field, always respecting its specifications. Lock the sensor position by turning the fixing ring clockwise until you feel that it is firm.

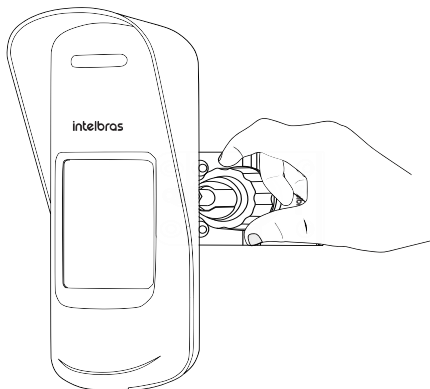

- » The corner fixing tabs can be easily detached if not in use.

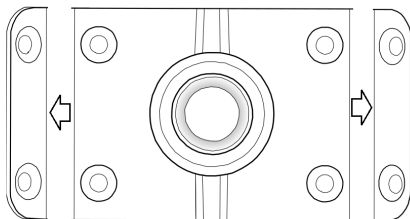

*Detaching the base*

# Term of Warranty

---

It is expressed that this contractual warranty is granted according to the following conditions:

---

Customer name:

Customer's signature:

Tax Invoice No.

Date of Purchase:

Model:

Serial No.:

Retailer

---

1. All parts, pieces and components of this product are warranted against any manufacturing defects, which may arise within a period of 1 (one) year - being 90 (ninety) days of legal warranty and 9 (nine) months subject to contractual warranty - from the date when the Customer purchased the product, according to the product purchase tax invoice, which is an integral part of this Term throughout the Brazilian territory. This contractual warranty expressly includes the product exchanges in case of manufacturing defect. If no manufacturing defect is confirmed, but there is a failure due to improper use, the Customer shall bear any of these incurred expenses.
2. The product must be installed according to the Product Manual and/or Installation Guide. If your product requires to be installed and configured by a skilled technician, you should seek for a reliable and skilled professional, but the costs of such services are not included in the product price.
3. Once the defect is confirmed, the Customer shall contact immediately the nearest Authorized Service listed in the report provided by the manufacturer, they are the only professionals authorized to check and remedy the defect within the warranty term provided herein. If it is not observed, the warranty is void, characterized as product infringement.
4. Eventually, if the Customer requests service at home, he/she may contact the nearest Authorized Service to ask for fee quotation of a technical visit. If it is necessary to withdraw the product to be repaired, the incurred expenses such as transpor-

tation and insurance costs, including taking and return after repaired, are under responsibility of the customer.

5. The warranty will be entirely voided if any of the following cases occur: a) if the defect is not due to manufacturing, but caused by the Customer or by third parties foreign to the manufacturer; b) if the product damages are caused by accident, disasters, agents of nature (lightning, flooding, landslide, etc.), humidity, network voltage, over-voltage caused by accident or excessive network voltage fluctuations), installation/use in disagreement with the user's manual or due to natural wear of parts, pieces and components; c) if the product had suffered any effects of chemical, electromagnetic, electric or animal (insects, etc.) nature; d) if the product serial number was altered or erased; and e) if the appliance is flawed.
6. This warranty does not cover data loss, therefore, in case of a product, it is advisable to the Customer to regularly make secure backup of the product data.
7. Intelbras is not liable for the installation of this product, as well as eventual attempts of fraud and/or sabotage in their products. Keep software and applications up to date, and if necessary, the required network protections against intrusions (hackers). The equipment is warranted against defects under normal conditions of use, and it is important to bear in mind that, because it is an electronic equipment, it is not protected from attempts of frauds or misleading actions that may interfere in its correct operation,
8. After its useful life, the product must be delivered to an Intelbras authorized support service or perform environmentally proper final disposal in order to avoid environmental or health impacts. If you prefer, useless cells and batteries as well as other Intelbras branded electronic appliances may be disposed at any Green Eletron collection points (electro-electronic residues management company to which we are associated). If you have any questions about the reverse logistics process, contact us by phone (48) 2106-0006 or 0800 704 2767 (from Monday to Friday at 8 AM to 8 PM, and on Saturday at 8 AM to 6 PM) or via e-mail [suporte@intelbras.com.br](mailto:suporte@intelbras.com.br).

Also under these supplementary Term of Warranty, Intelbras S/A reserves the right to alter general, technical or aesthetics features without prior notice.

All images in this manual are for illustrative purposes only.

# intelbras

---



*talk to us*

**Customer Support:** ☎ (48) 2106 0006

**Forum:** [forum.intelbras.com.br](http://forum.intelbras.com.br)

**Support via chat:** [intelbras.com.br/suporte-tecnico](http://intelbras.com.br/suporte-tecnico)

**Support via e-mail:** [suporte@intelbras.com.br](mailto:suporte@intelbras.com.br)

**Customer Service:** 0800 7042767

**Where to buy? Who installs it?** 0800 7245115

Produced by: Intelbras S/A – Indústria de Telecomunicação Eletrônica Brasileira  
Rodovia BR 459, km 124, 1325 – Distrito Industrial – Santa Rita do Sapucaí/MG – 37540-000  
CNPJ 82.901.000/0016-03 – [www.intelbras.com.br](http://www.intelbras.com.br)

01.22  
Made in Brazil