

V3 Standing Desk

FV3-200 Frame Only

UPLIFT DESK

Work better. Live healthier.

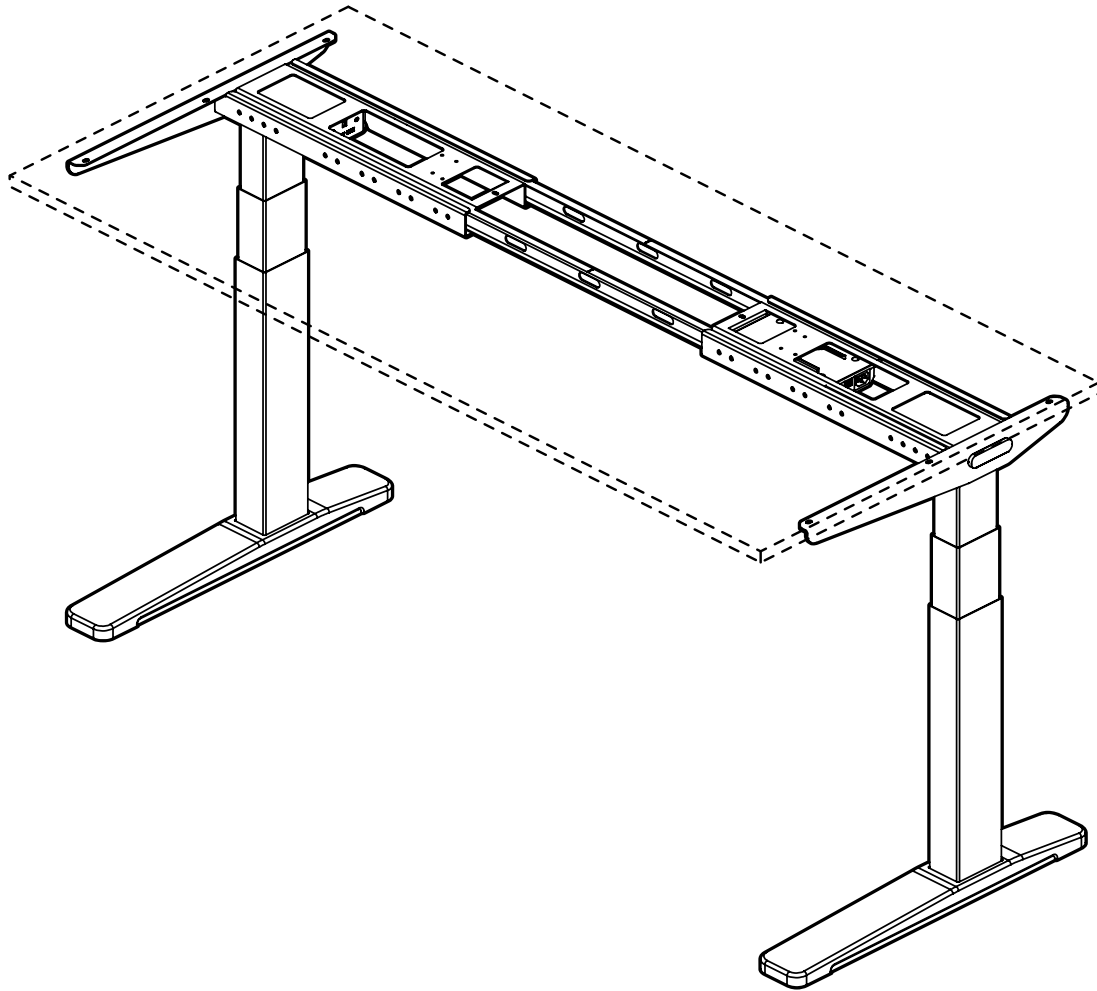

For assembly assistance, chat us at upliftdesk.com/contact, call 800-349-3839, or email support@upliftdesk.com ©2025 UPLIFT Desk®. All Rights Reserved.

The following patents apply to this product: US 11,109,672; CA 3,061,786; DE 202019005934

Scan for product
webpage



Safety and Warnings

WARNING: Read all instructions before assembly. Failure to assemble or operate the desk properly may result in damage or personal injury. Retain this manual for future reference or new owners.

WARNING: Keep fingers and body parts clear of the moving desk. Check the desk's surroundings on all sides before raising or lowering the desk to ensure there are no obstacles that can cause damage or personal injury.

WARNING: Ensure all desk and accessory cords have enough slack so they don't pull as the desk moves up and down.

WARNING: Keep children away from the desk unless supervised. Misuse of the desk can cause personal injury. If children cannot be supervised at all times, use the desk keypad's safety lock feature or remove the power cord to prevent operation.

WARNING: Risk of serious injury or death. Adjusting the height of the desk could pinch or crush body parts trapped between the desktop, frame, or accessories and the floor or any stationary objects under the desk. Ensure that any body part under the desk or accessories are removed from any pinch or crush zones prior to moving the desk.

WARNING: Be sure there is a gap of at least 1" between the moving parts of the standing desk and objects located adjacent to it to avoid pinching and crushing hazards. Move the desk through its full range of motion to ensure a gap of 1" or more is maintained around the perimeter of the desk.

WARNING: The desk is designed for indoor use only. Use of desk outdoors or in damp locations can damage the desk and can cause risk of electric shock and/or fire.

WARNING: There is a risk of desk failure or electric shock if desk components become wet. If liquid is spilled on any electrical desk component, disconnect the desk from power immediately. Clean up the spill with a dry cloth and plug the desk back into the power outlet.

WARNING: Only plug the desk into a properly grounded 100-240V power outlet. Using a voltage converter is considered improper use and can cause damage to the desk.

WARNING: Do not open or insert any object into the desk legs or control box. Doing so may cause damage and can cause risk of electric shock.

WARNING: Never use the desk if the power cord or plug becomes damaged to avoid risk of fire and/or electric shock. Contact UPLIFT Desk for a replacement power cord if it is damaged in any way.

WARNING: Persons with limited mental or physical capabilities who are unable to comprehend the safe operation of the height adjustability feature must not operate the desk.

WARNING: Inspect the desk regularly and stop using immediately if you notice damaged or loose parts. Only replace damaged desk parts with authorized UPLIFT Desk parts.

Please read these instructions carefully. This desk is height adjustable to fit the user's height. Inappropriate use of this desk can cause property damage and/or bodily injury. Under no circumstances does the manufacturer accept warranty or liability claims for damages caused from improper use of this product. Provide this manual to any new user.

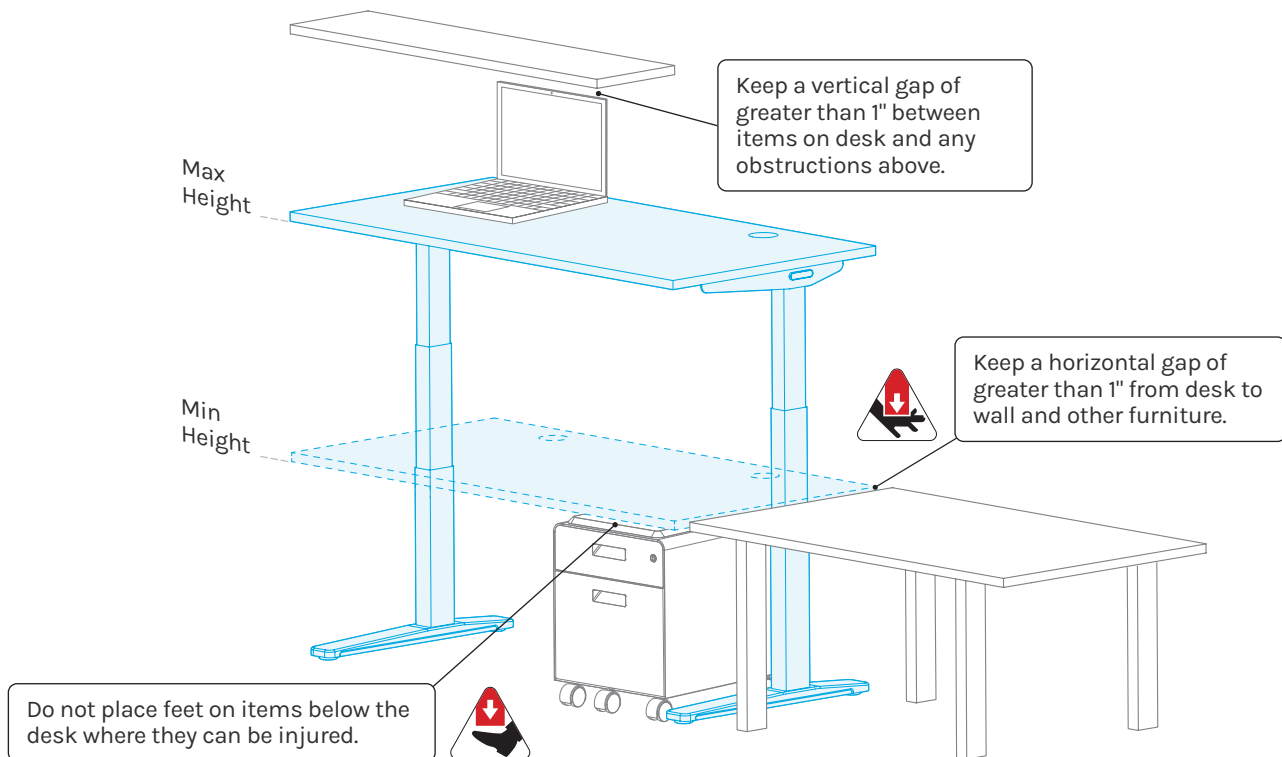



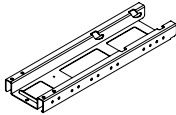
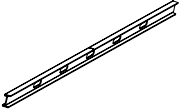
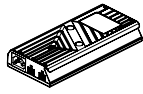
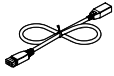
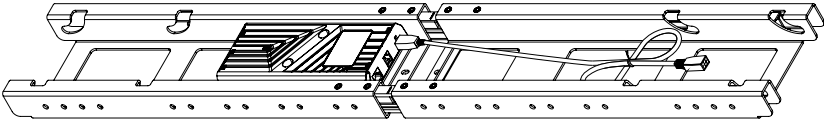

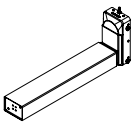
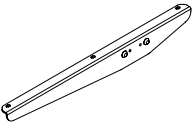
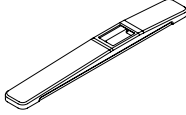
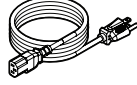
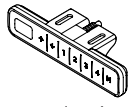
Package Contents



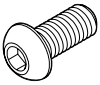

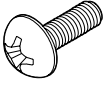
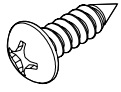
<p>Crossbar End qty 2</p> 	<p>Crossbar Rail qty 2</p> 	<p>Control Box</p> 	<p>Leg Extension Cable</p> 
<p>Above parts ship pre-assembled as shown below.</p> 			

<p>Leg qty 2</p> 	<p>Side Bracket qty 2</p> 	<p>Foot qty 2</p> 	<p>Power Cord</p> 	<p>Keypad</p>  <p>Keypad varies. Ships in separate box.</p>
--	---	---	---	--

Included Hardware

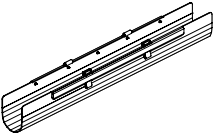
<p>M8 x 16 Screw qty 8 (pre-installed)</p>  <p>Ships installed in Feet & Side Brackets.</p>	<p>M10 x 8 Set Screw qty 8 (pre-installed)</p>  <p>Ships installed in Crossbar Ends.</p>	<p>#10-24 x 5/8" Truss Head Screw qty 8</p> 	<p>#10 x 5/8" Wood Screw qty 4</p> 	<p>Logo Plate qty 2</p> 
--	---	--	--	---

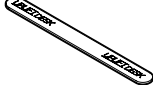
Cable Management

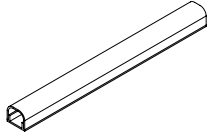
<p>FlexMount Cable Manager</p> 	<p>Cable Manager Bracket qty 2</p> 	<p>Hook & Loop Strip qty 10</p> 	<p>Cable Mount qty 10</p> 	<p>Keypad Cable Channel</p> 
--	--	---	---	---

Tools Required

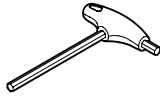
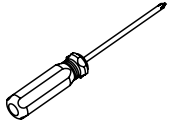
<p>5mm Allen Wrench (included)</p> 	<p>Phillips Screwdriver</p> 
--	---

Required Hardware (not included)

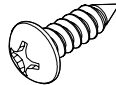
<p>#10 x 5/8" Wood Screw qty 8</p> 
--

The enclosed steps detail how to assemble a C-Frame or T-Frame desk using your own desktop, please scan the appropriate QR code below for the correct assembly instructions with UPLIFT provided desktops.

C-Frame Assembly Instructions

This QR code provides instructions for assembling a desk with C-Frame Feet and Side Brackets shown below.



Scan for C-Frame assembly

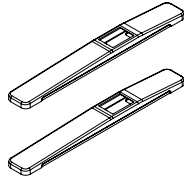

C-Frame Feet

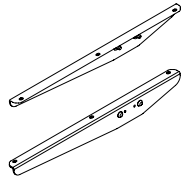

C-Frame Side Brackets



Scan for T-Frame assembly

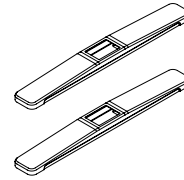

T-Frame Feet

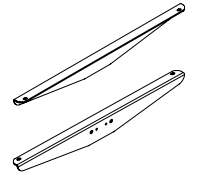

T-Frame Side Brackets

Step 1 - Inventory of Parts

Before discarding any packaging, lay out all the parts from each box and verify that every item listed in the package contents is present.

If a part seems to be missing, check the boxes carefully to ensure it isn't there. If you confirm the part is missing, contact us at (800) 349-3839 or email support@upliftdesk.com before starting assembly.

Leave these parts assembled as shipped.

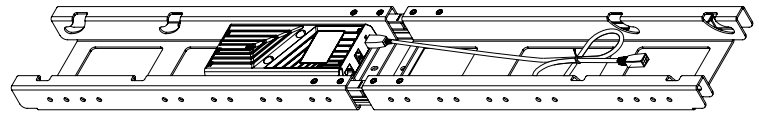

Step 2 - Attach Crossbar Ends to Desktop

Place desktop on a clean surface with the bottom side facing upward.

Place the Crossbar End and Crossbar Rail assembly on the desktop approximately where shown.

Note: The Control Box side can be positioned on either the left or right.

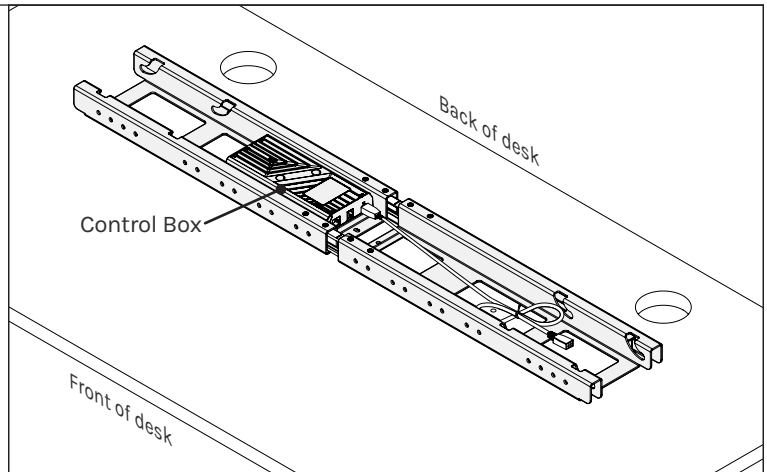

Loosen Set Screws indicated by the arrows with the Allen Wrench.

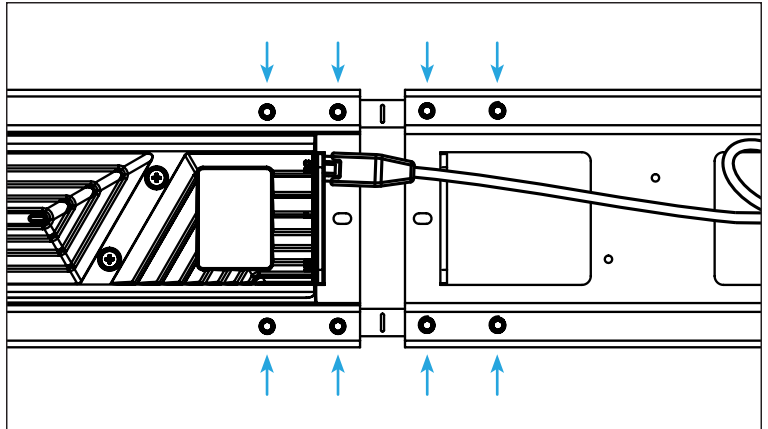

Slide the Crossbar Ends apart so that the outside ends are near the sides of the desktop.

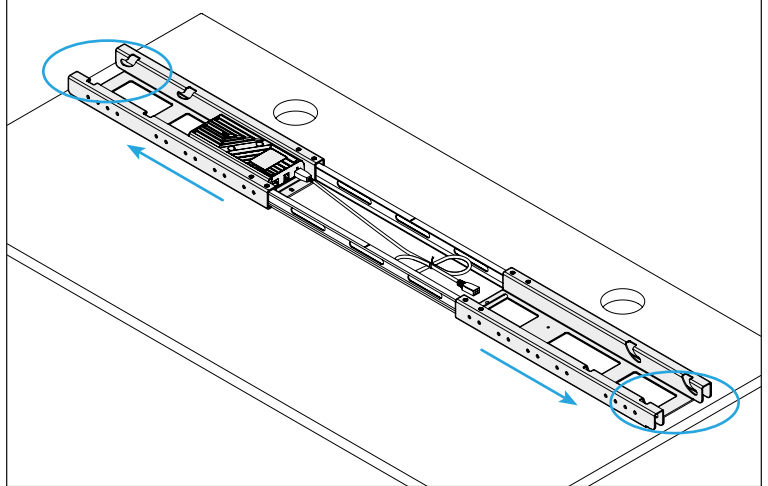

Step 3 - Attach Legs

Insert a Leg into the slots of each Crossbar End as shown.

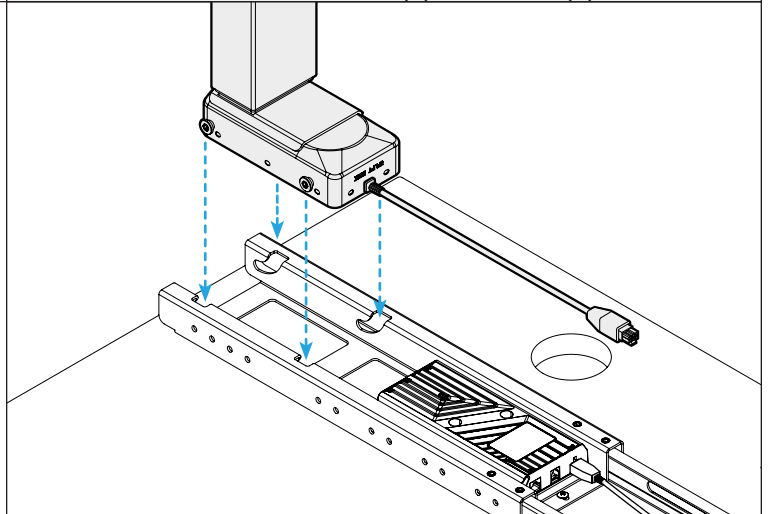

Note: If needed, slide Crossbar Rails toward the middle so they don't block the Crossbar End slots.

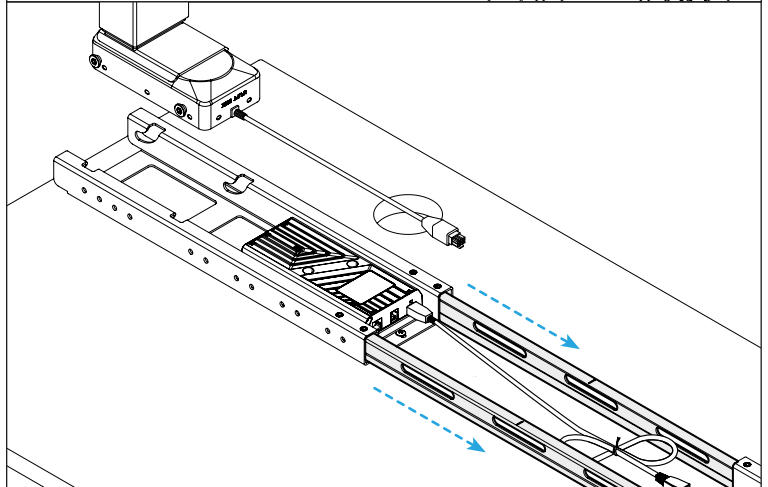

Step 4 - Attach Side Brackets to Legs

Place the Side Brackets as shown.

Note: If assembling a C-frame, make sure the long ends of the Side Brackets face the front of the desk

Align Side Bracket screws with Leg holes as shown and insert with Allen wrench. **Make sure these screws are tight!**

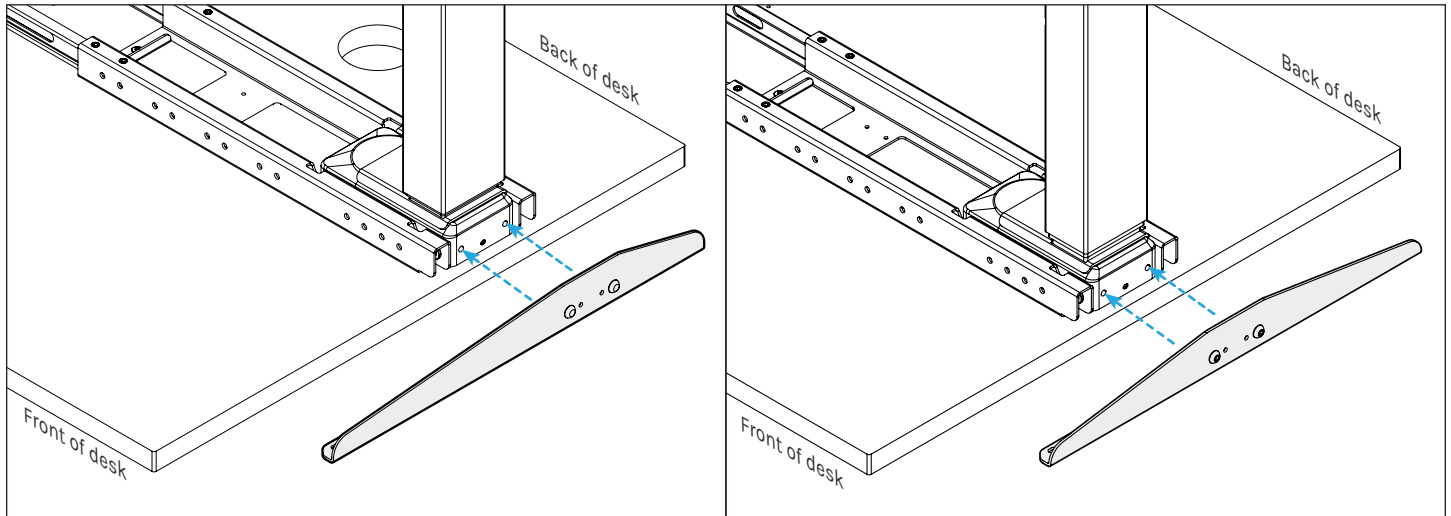

C-Frame Side Brackets

T-Frame Side Brackets

Step 5 - Drill Frame Attachment Holes

Align the frame on the desktop so that the ends of the Side Brackets are approximately centered between the front and back edges of the desktop and approximately 1/2" in from each side edge.

Mark the center of each of the Side Bracket and Crossbar End holes.

- C-Frames have three holes in the Side Brackets
- T-Frames have two holes in the Side Brackets

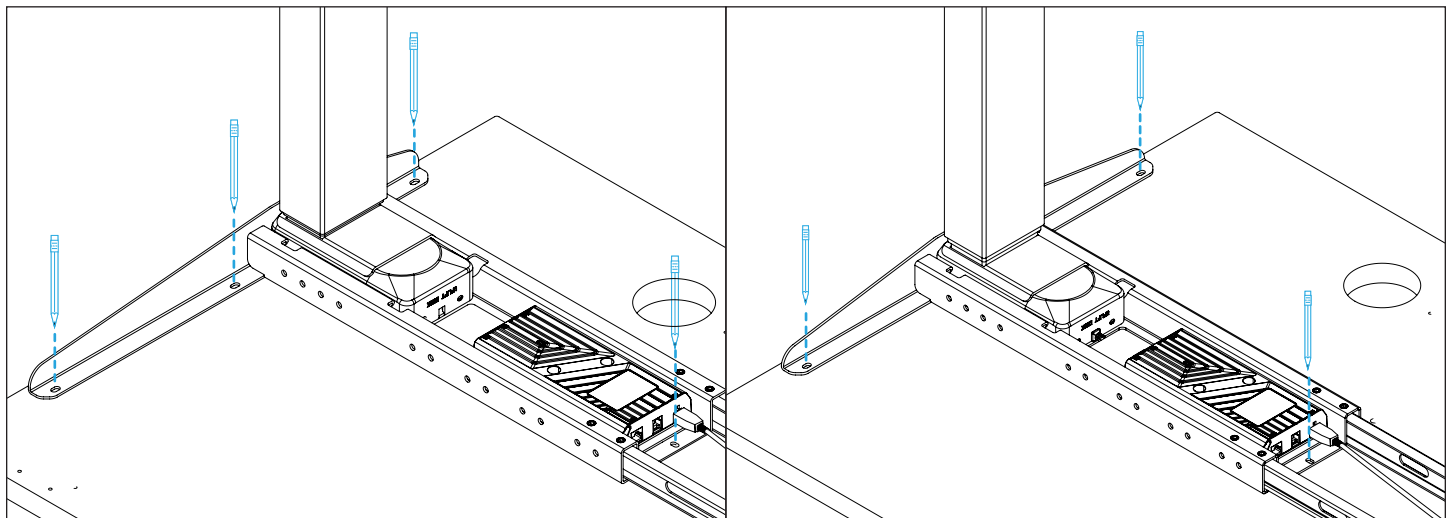

C-Frame Hole Locations

T-Frame Hole Locations

IMPORTANT: DRILL NO DEEPER THAN 1/2" to avoid drilling through your desktop. To ensure this, wrap a piece of tape around your drill bit 1/2" from the tip. Stop drilling just before the tape touches the desktop.

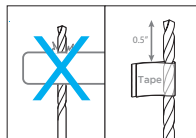

Move the frame out of the way and drill 1/2" deep pilot holes at your pencil marks using a 1/8" drill bit.

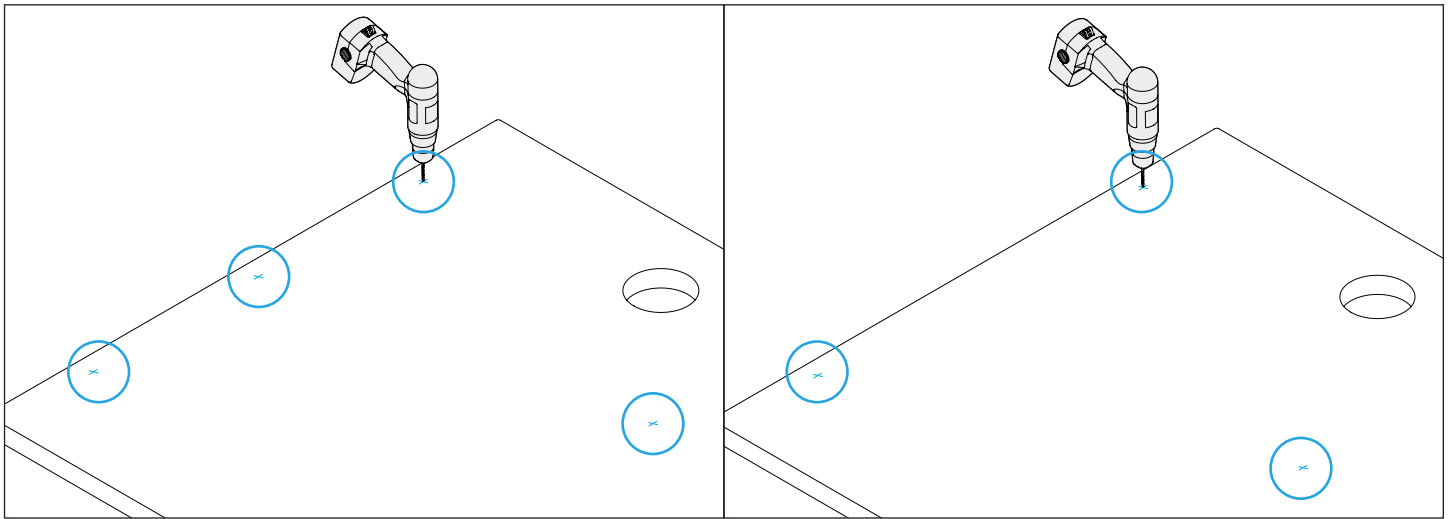

C-Frame Drill Locations

T-Frame Drill Locations

Step 6 - Frame Attachment

Replace the frame assemblies back onto the desktop and realign the Side Bracket and Crossbar End holes with the holes drilled in the previous step.

Use a Phillips screwdriver to insert a #10 x 5/8" Wood Screw into each hole. **Make sure these screws are tight, but be careful not to overtighten to avoid stripping!**

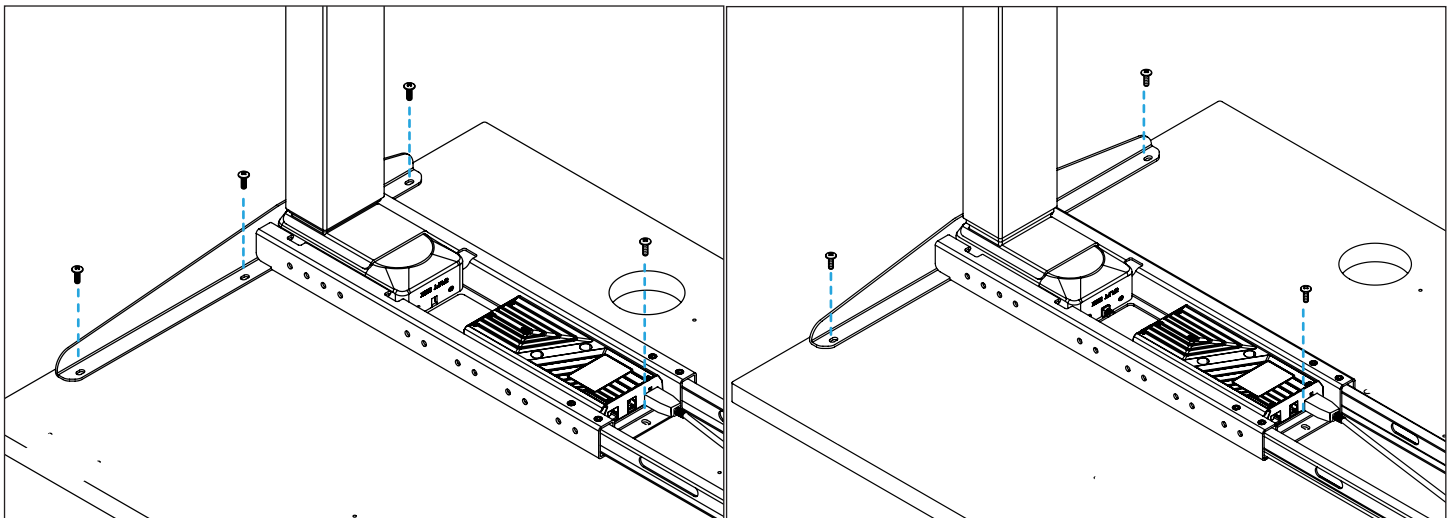

C-Frame Screw Locations

T-Frame Screw Locations

Step 7 - Center Crossbar Rails

Center the Crossbar Rails between the Crossbar Ends using the indicator marks.

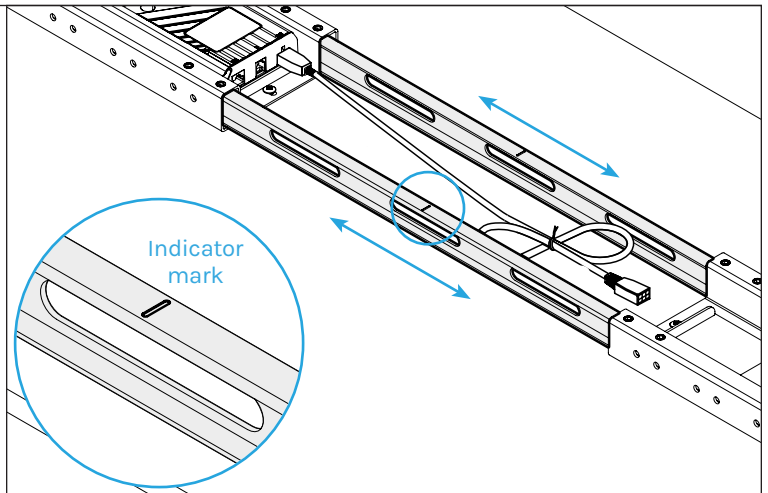

Tighten the eight M10 x 8 Set Screws.

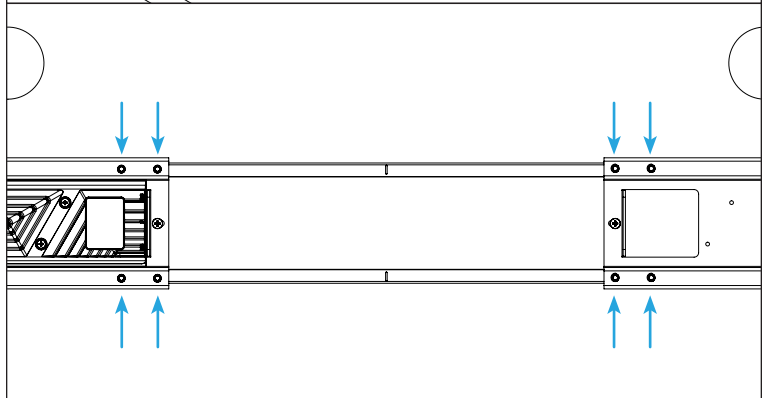

Step 8 - Attach Feet

Place a Foot on each Leg as shown.

Note: If assembling a C-frame, make sure the long ends of the Feet face the front of the desk.

Align screws in Feet with Leg holes and insert with Allen wrench. **Make sure these screws are tight!**

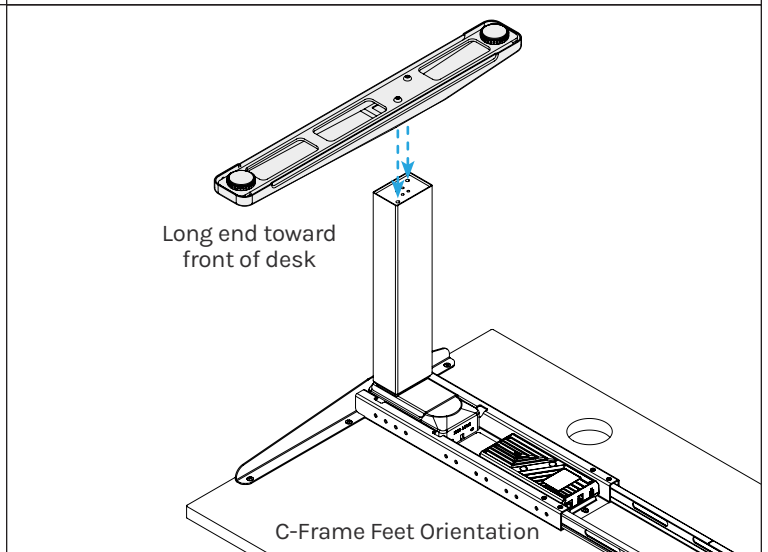

Step 9 - Attach Keypad

Position the Keypad where you would like it to be located and refer to the directions in Step 5 to mark and drill attachment holes.

Using a Phillips screwdriver, attach the keypad using two of the included #10 x 5/8" Wood Screws.

Do not overtighten the screws to avoid stripping.

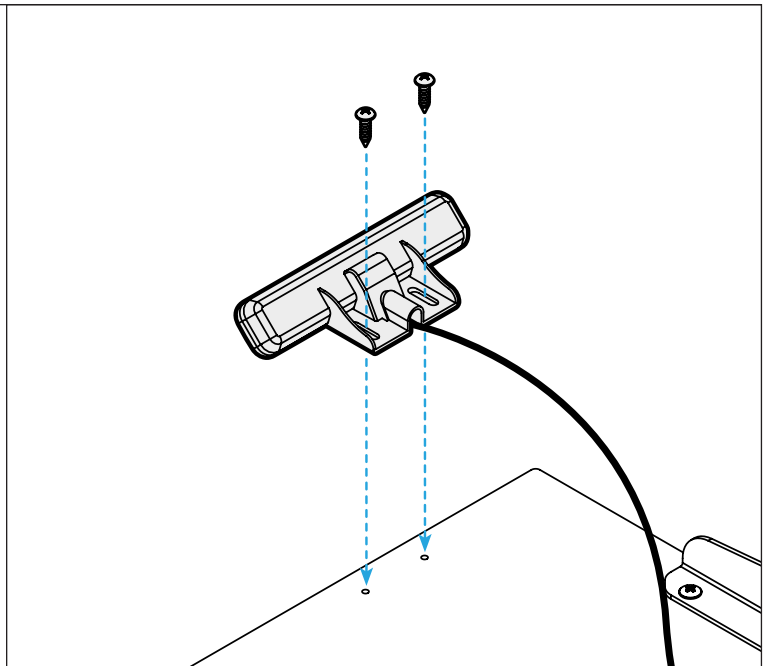

Separate the top and bottom halves of the Keypad Cable Channel.

Peel backing off of the bottom half to expose the adhesive and press it onto the desktop about 3" to 4" behind the Keypad as shown here.

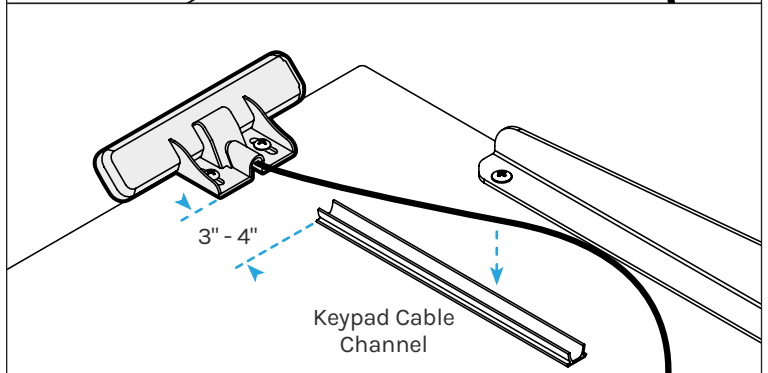

Route the Keypad cable through the bottom half and reattach the top.

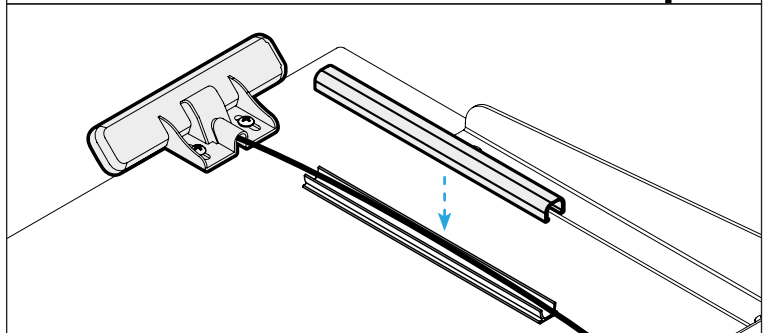

Step 10 - Connect Cables

Note: Keypad and Control Box may be on the opposite sides of the desk when assembled.

- 1 Connect the Power Cable to AC port on Control Box.
- 2 Connect the cable from Leg closest to the Control Box to M1 port.
- 3 Connect the cable from opposite Leg to the Leg Extension Cable which is pre-connected to M2 port.
- 4 Connect the Keypad cable to HS port.

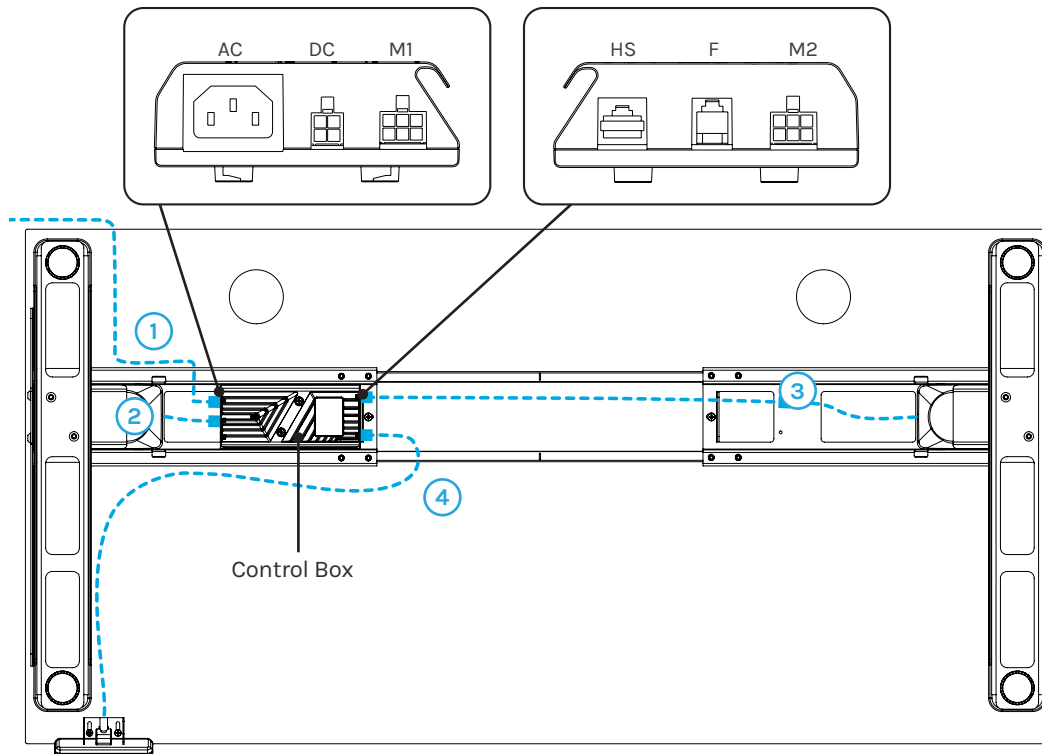

Step 11 - Cable Management

Peel backing off Cable Mounts and press them onto the desktop. These can be placed anywhere, but some recommended locations are shown to the right with dots.

Thread a Hook & Loop Strip through the Cable Mount, bundle cables, and secure.

Note: Hook & Loops Strips can also be used without the Cable Mounts by sliding them under or through the Crossbar Rails.

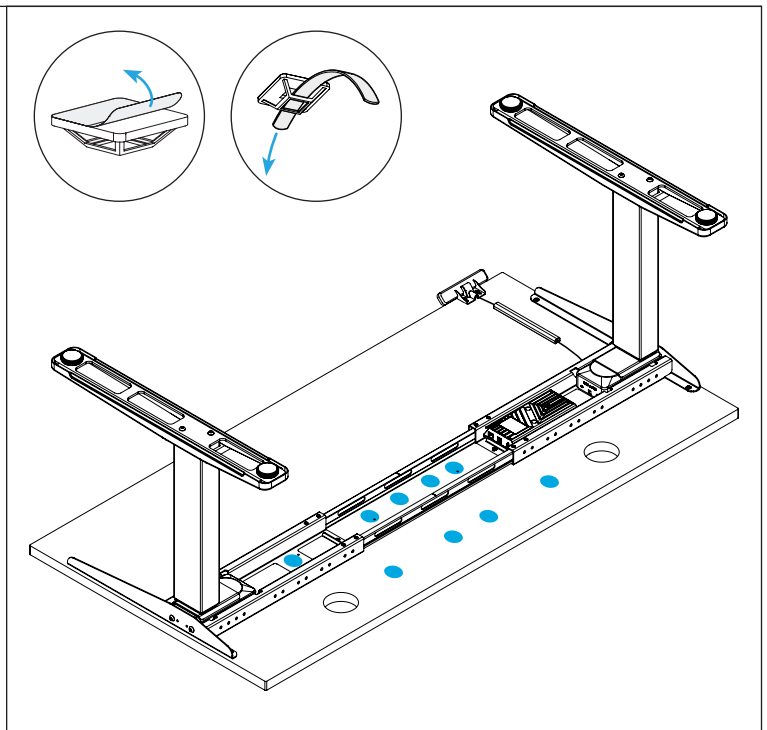

Step 12 - Optionally Install Casters and/or Other Accessories (if purchased)

To optionally install casters, unscrew leveling glides counterclockwise, then screw in casters clockwise until tight.

Note: Before flipping the desk over, install any other accessories that attach to either the desk frame or bottom of the desktop such as desk drawers, keyboard trays, CPU holders, and surge protectors.

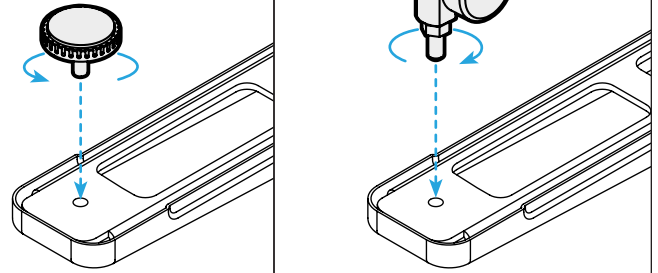

Step 13 - Install FlexMount Cable Manager

Refer to the separate instructions provided for the FlexMount Cable Manager for installation.

Note: You will install only the Cable Manager Brackets first, then complete the rest of the assembly steps after the desk is flipped upright.

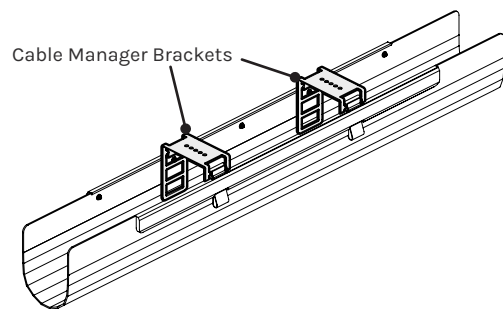

Step 14 - Flip Desk Over (two people recommended)

Caution: Be aware of cables and attached accessories as you flip the desk over.

Gradually lift the front of the desk until the back of the Feet rest on the floor, then adjust your grip and rotate the desk upright.

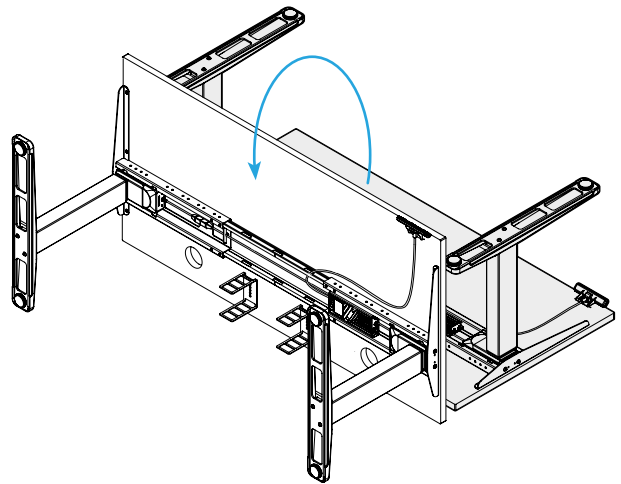

Step 15 - Attach Logo Plates

Before attaching Logo Plates, use the Allen Wrench to tighten Side Bracket screws once again as shown here.

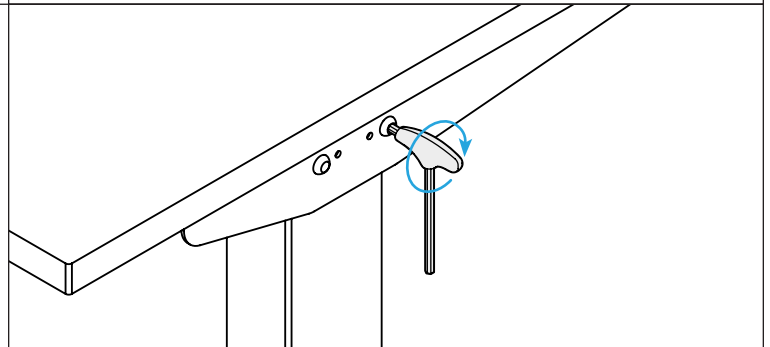

Align Logo Plate posts with the holes shown, then press them firmly into Side Bracket.

Repeat on other side.

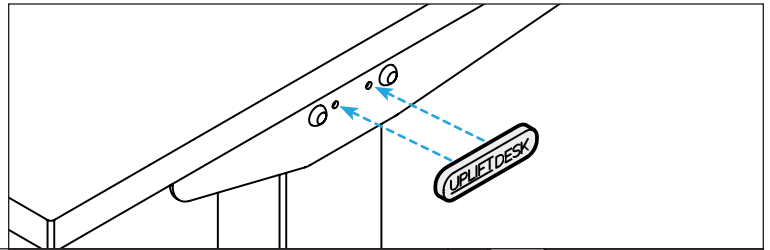

Position Desk (two people recommended)

To move the desk to its final location, lift under the Side Brackets. Adjust the leveling glides to accommodate for uneven floors.

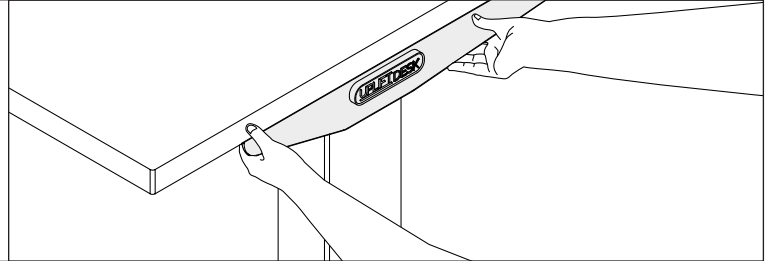

Connect Desk to Power

Plug Power Cord into a grounded outlet.

When connected to power, the Control Box power indicator LED and Keypad displays will illuminate.

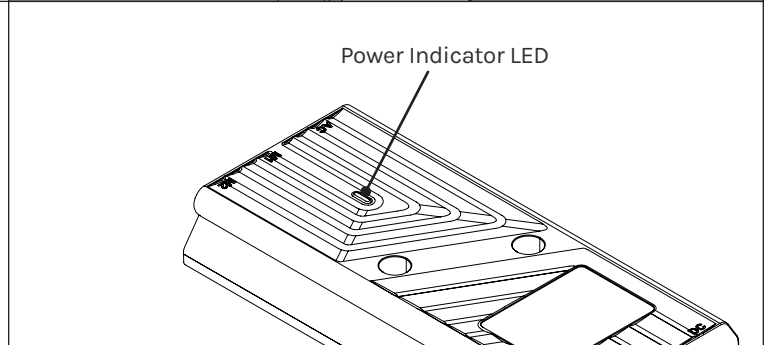

Desk Reset Procedure

IMPORTANT: Before using your desk, perform the following Desk Reset Procedure to sync the Legs and Control Box. You can perform this procedure anytime, it's particularly useful to reset any error codes.

1. Remove anything under the desk that would prevent it from moving to its lowest height.
2. Press the "down" button to lower the desk to its lowest position.
3. Press and hold the "down" button again for about 10 seconds. Keypads with a display will show "ASr". Paddle Keypads will show "RESET."
4. Press and hold the "down" button again until the desk lowers slightly, rises, and stops.
5. If the desk is working properly, you're done. If the desk is not working properly, continue with the following steps.
6. Unplug the power cord from the electrical outlet.
7. Press and hold the "down" button for 10 seconds to discharge any stored power in the Control Box.
8. Plug the desk back in and perform this entire Desk Reset Procedure again.

Advanced Keypad Programming

See below, scan the QR code, or visit <https://www.upliftdesk.com/uplift-desk-assembly-programming/> for Advanced Keypad Programming steps.



Saved Desk Heights

Save sitting and standing heights.

1. Move the desk to the desired height.
2. Tap the “M” button followed by one of the numbered buttons.

See One-Touch, Constant-Touch, or Double-Tap section below for instructions on moving the desk to a saved height.

One-Touch, Constant-Touch, or Double-Tap

One-touch (default setting) requires just a single touch of a numbered button to automatically move the desk to a saved height.

Constant-touch requires a numbered button to be continuously pressed to move the desk to a saved height.

Double-tap requires two taps of a numbered button to move the desk to a saved height.

Follow the steps below to toggle between these modes.

1. Move the desk to its lowest position.
2. Press and hold the “down” button until the display shows “ASr”.
3. Press and hold the number “1” button until the display shows “10.1” (one-touch), “10.2” (constant-touch), or “10.8” (double-tap). Release the button when the preferred selection is displayed.
4. When the display changes back to “ASr”, press and hold the “down” button until the desk lowers and rises slightly and the display changes back to the desk height setting.

Desk Height Calibration

Ensure the displayed desk height matches the actual desk height.

1. Move the desk to its lowest position.
2. Measure from the floor to the top of the desk. If the measurement does not match the display, follow the steps below.
3. Press and hold the “down” button until the display shows “ASr”.
4. Press and hold the “M” button until the displayed desk height begins flashing.
5. Tap the “up” or “down” button until the displayed height matches the measured height.
6. When the display changes back to “ASr”, press and hold the “down” button until the desk lowers and rises slightly and the display changes back to the desk height setting.

Keypad Lock

Lock the keypad for safety and to prevent accidental adjustments.

1. Hold the “M” button until the display shows “LOC.”
2. To unlock your keypad, hold the “M” button until the display shows the desk height.

If power is lost the keypad will return to the unlocked setting.

Units of Measurement

Switch between inches and centimeters on your display.

1. Move the desk to its lowest position.
2. Press and hold the “down” button until the display shows “ASr”.
3. Press and hold the number “2” button until the display shows “10.3” (centimeters) or “10.4” (inches). Release the button when the preferred selection is displayed.
4. When the display changes back to “ASr”, press and hold the “down” button until the desk lowers and rises slightly and the display changes back to the desk height setting.

Min and Max Height Limits

Set the desk’s minimum and maximum height limits to prevent the desk from colliding with anything when raising or lowering.

Set minimum desk height limit:

1. Move the desk to where you want the minimum height limit to be set.
2. Tap the “M” button once and “S-” will appear on the display.
3. Tap the “down” button and the display will flash “S-.”
4. Press and hold the “M” button until the display shows “000” and changes to the desk height.

Set maximum desk height limit:

1. Move the desk to where you want the maximum height limit to be set.
2. Tap the “M” button once and “S-” will appear on the display.
3. Tap the “up” button and the display will flash “S-.”
4. Press and hold the “M” button until the display shows “999” and changes to the desk height.

Remove desk height limits:

1. Tap the “M” button once and the display will show “S-.”
2. Press and hold the “M” button until the display shows “555” and changes to the desk height.

Anti-Collision Sensitivity

Adjust the setting of the anti-collision system to make the desk more or less sensitive to collisions with objects above or below the desk.

1. Move the desk to its lowest position.
2. Press and hold the “down” button until the display shows “ASr”.
3. Press and hold the “up” button until the display shows “10.5” (most sensitive), “10.6” (moderately sensitive), or “10.7” (least sensitive). Release the button when the preferred selection is displayed.
4. When the display changes back to “ASr”, press and hold the “down” button until the desk lowers and rises slightly and the display changes back to the desk height setting.

Troubleshooting

Desk Troubleshooting

See below, scan the QR code, or visit

<https://www.upliftdesk.com/uplift-desk-reset-troubleshooting-steps/> for troubleshooting steps.



Error Code	Description	Troubleshooting Solution
H01	Overheated	The desk motor has a 10% duty cycle to protect from overheating. This means that in a 20 minute period if your desk motor is activated continuously for 2 minutes you will need to let it rest for at least 18 minutes. Otherwise you may see an H01 code on your keypad.
E01-E06	Overcurrent issue	<ol style="list-style-type: none">1. Ensure the desk does not exceed the 355 lb weight limit2. Ensure there is no mechanical interference or obstruction3. Perform the Desk Reset Procedure
E07-E012	Uneven legs	<ol style="list-style-type: none">1. Ensure all cables are firmly connected2. Ensure there is no mechanical interference or obstruction3. Perform the Desk Reset Procedure

Error Codes

If your keypad display shows any of the error codes listed above, perform the Desk Reset Procedure. If the error message persists after performing the Desk Reset Procedure or if there is a height difference between the Legs of more than 1.5", email support@upliftdesk.com or call 800-349-3839.

Starting & Stopping

If your desk starts and stops as you try to raise or lower it, make sure the Control Box is securely attached to the frame. The Control Box MUST be attached to your frame in order for your desk to function properly. If the Control Box is secure and the problem persists, perform the Desk Reset Procedure.

Loss of Power

Perform the Desk Reset Procedure any time the desk is unplugged or power has been interrupted.

UPLIFT DESK

Work better. Live healthier.

upliftdesk.com

support@upliftdesk.com

800-349-3839

512-614-3152

Save This Manual: Study this manual carefully. If this product is sold, please provide this manual to the buyer, installers, or support personnel operating the product.

Copyright Notice: This manual is a component of this UPLIFT Desk product. This manual is a part of the scope of delivery, even if the item is resold. This manual is also available on the UPLIFT Desk website: upliftdesk.com. This manual is subject to United States copyright law.