

Petsuper®

PLT01 Automatic Smart Cat Litter Box

(Auto Waste Disposal + Auto Litter Refill)

User Manual

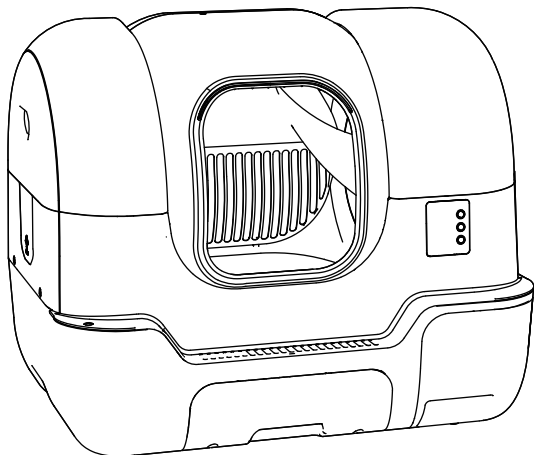

For safe operation and compliance with warranty terms, retain this user guide after complete reading.

Table of Contents

Usage Tips

Important Notice to Users	Page 1
Safety Guidelines	Pages 1-2
Packing List	Page 3

Operation Guide

Product Overview	Pages 4-6
Installation Guide	Pages 7-12
Function Instructions	Page 13
Troubleshooting	Pages 14-16
Auto Litter Cleaning & Waste Disposal Functions	Pages 17-19

Maintenance

Cleaning & Maintenance	Pages 20-26
------------------------------	-------------

Specifications & Warranty

After-Sales Service Card	Page 27
Repair Service Record	Page 28
Troubleshooting Guide	Page 29
Environmental Compliance List	Page 30
Product Specifications	Page 31
App Usage Guide	Page 32

(Please detach the After-Sales Service Card before use)

Important Notice to Users

- Thank you for choosing the Petsuper PLT01 Automatic Smart Cat Litter Box. We are committed to transforming pet care through technology-driven innovation, making pet ownership more effortless and enjoyable.
- The power adapter must be connected to a certified power socket compliant with national standards and properly grounded. Under no circumstances should you cut or remove the grounding pin of the power adapter.
- Read this manual thoroughly before use. By installing or operating this product, you acknowledge that you have thoroughly reviewed and accepted the safety guidelines herein.
- The company shall not be held liable for any accidents, damages, or losses resulting from improper operation, nor assume any legal obligations.
- All rights to interpret or modify this statement are exclusively reserved by Petsuper.

Safety Guidelines

Important Safety Instructions

**Failure to follow these instructions may result in improper functioning of the product or other unintended damages*

- The device must be installed and used strictly according to the instructions in this manual.
- Not suitable for kittens under 6 months old or cats weighing less than 1.5 kg (3.3 lbs).
- This product is designed for clumping cat litter, such as tofu litter, mixed litter, bentonite litter, and mineral litter. Do not use non-clumping litter, such as crystal litter.

- .Do not scratch or damage the display screen with sharp objects.
- .For indoor use only. Keep the device away from direct sunlight and heat sources.
- .Although the product operates on low-voltage power for safety, pets chewing on the power cord may still pose an electrical hazard. Secure and hide the power cord to prevent pets from chewing on it.
- .Do not place the device in high-temperature or high-humidity environments.
- .If you notice your pet chewing on the power cord, stop the behavior immediately.
- .Use only the original power adapter. Using an unauthorized adapter may damage the device or pose safety risks.
- .Place the unit on a stable, hard, and level surface, ensuring it does not touch walls.
- .Do not tilt or tip over the device to prevent potential safety hazards.
- .Do not immerse the base of the unit in water or expose it to excessive moisture.
- .The bottom of the unit contains weight sensors. When moving the device, handle it with care and lift it gently.
- .If the product will not be used for an extended period or needs to be relocated, unplug the power cord.
- .If children use this device, ensure they are supervised by an adult.
- .Repairs should only be performed under the guidance of a professional technician to avoid potential risks or damage.
- .Do not place objects on top of the device or apply pressure to its upper surface, as this may interfere with its proper functioning.
- .Before a long holiday, please check whether the litter in the automatic litter box is sufficient and ensure the waste bin has enough capacity.
- .If you encounter any issues while using the product, please contact customer service promptly.

Packing List

*After opening the package, check if the device is intact and verify that all accessories are present by comparing with the diagram below.

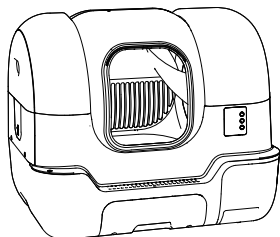

Main Unit *1

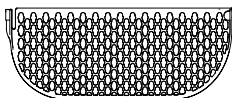

Short-Slot Litter Sifter for Mineral Litter Only *1

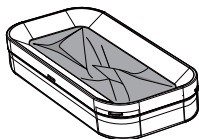

Waste Bag ×1

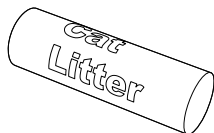

Waste sand bag ×1

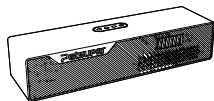

PC01 Odor Eliminator *1

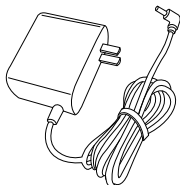

Power Adapter *1

User Manual

User Manual *1

Product Introduction

Component Instructions

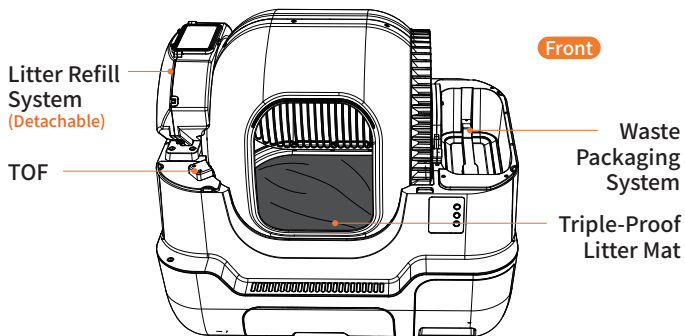
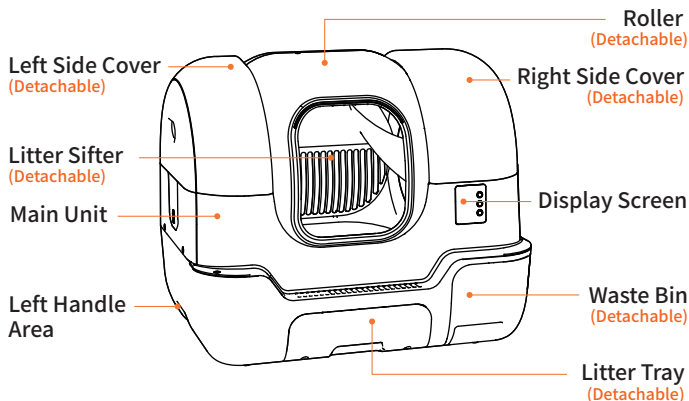

**As the product continues to be upgraded and optimized, there may be differences between the images and the actual product. Please refer to the actual product.*

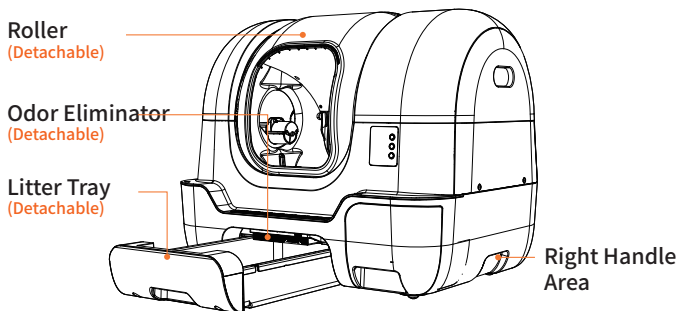
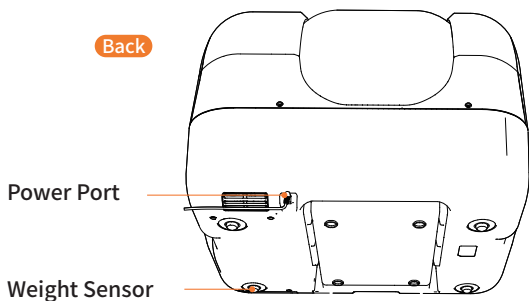

Product Introduction

Component Instructions



**As the product continues to be upgraded and optimized, there may be differences between the images and the actual product. Please refer to the actual product.*

Component Function Introduction

Component Name	Function Description
Litter Refill System	Stores and automatically replenishes litter in real-time to prevent emptying and sticking to the bottom.
Short-Slot Litter Sifter (Exclusive For Mineral Litter)	Designed for fine-grain litter such as bentonite and mineral litter, effectively sifting clumps. 
Long-Slot Litter Sifter (Exclusive For Tofu & Mixed Litter)	Efficiently sifts and filters clumps without clogging or leakage. 
Triple-Proof Litter Mat	Upgraded waterproof treatment, resistant to litter adhesion, scratch-resistant, bite-resistant, and easy to clean.
Automatic Waste Packaging System	Automatically seals waste bags, eliminating the need for manual handling.
PC01 Odor Eliminator	Releases a long-lasting, fresh fragrance without irritation.

Installation Guide

03

3-1 Roller Installation Instructions

1

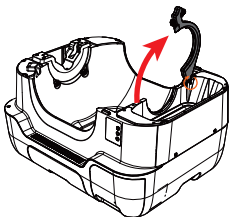

Lift the buckle to unlock.

2

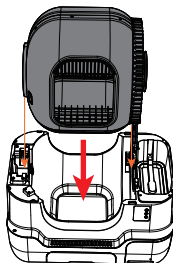

Place the roller into the main unit, ensuring the buckle clicks securely into place.

3

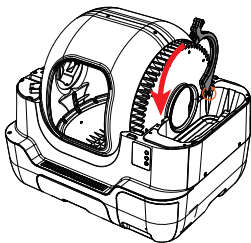

Drop the buckle to its original position.

4

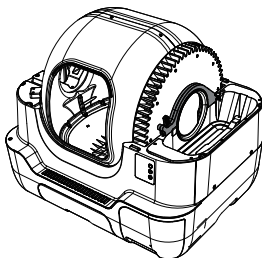

Final Result

Installation Guide

3-2 Litter Refill System Installation Instructions

1

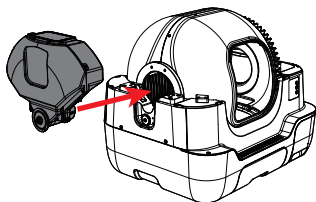

Place the litter bin in the direction of the arrow, ensuring the litter tunnel properly enters the roller.

2

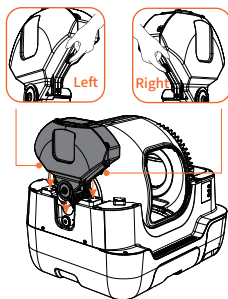

Lower the litter bin in the direction of the arrow and press it down to securely lock both side buckles.

3

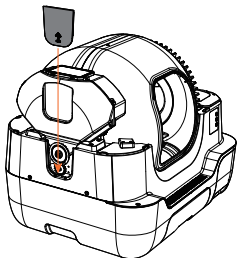

Place the baffle into place in the direction of the arrow after the litter bin is installed.

4

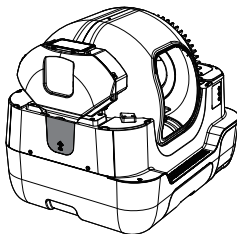

Final Result

Installation Guide

3-3 Waste Bag Installation Instruction

1

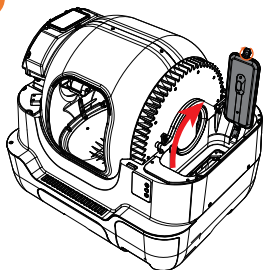

Lift the lid of the waste bin.

2

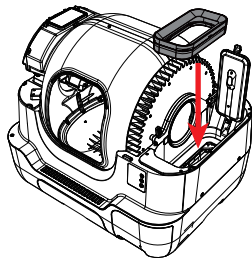

Place the waste bag in the indicated position.

3

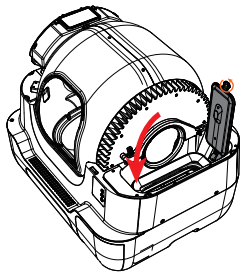

Place the lid back in its original position.

4

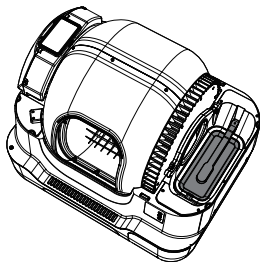

Final Result

Installation Guide

3-4 Odor Eliminator

1

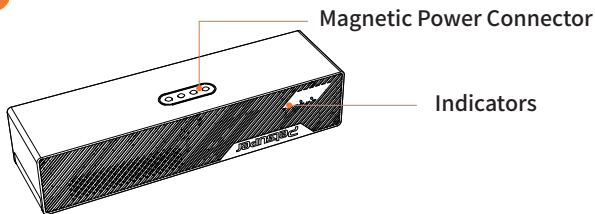

Power connector side facing up, indicator side facing outward.

2

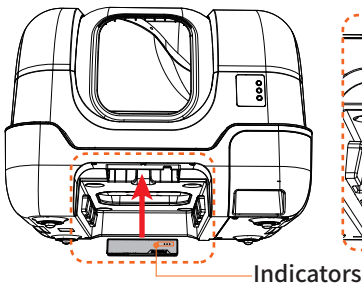

3

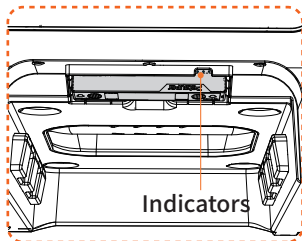

**Note: The effect after the odor eliminator is installed.*

**Note: Final Result*

Place the odor eliminator into the installation slot of the main unit, ensuring the magnetic power connector of the odor eliminator aligns with the corresponding connector inside the litter box.

Installation Guide

3-5 Litter Tray Installation Instructions

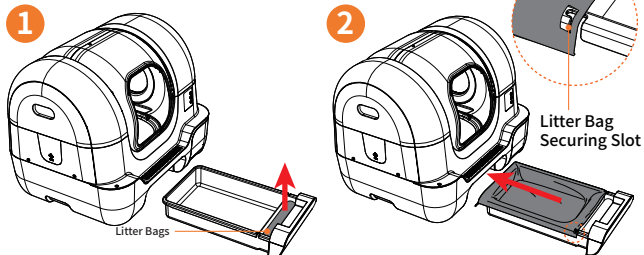

The litter tray features a designated area for placing litter bags (as shown in the image). You can also use regular trash bags here.

Clip both ends of the waste bag into the side slots (as shown in the image), then slide the litter tray into place in the direction of the arrow.

2

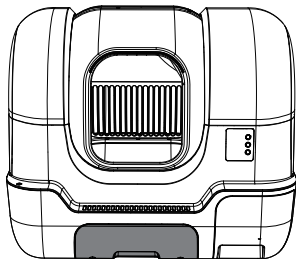

Final Result