

HelloRadio

V16

Remote Controller
Quick Start Guide

WWW.HELLORADIORC.COM



Introduction

Thank you for purchasing the Helloradio V16 Multi-protocol radio system. Helloradio is proud to bring this ground-breaking product to the market and would like to thank customers just like you and the community for making this dream possible. The version has had several improvements thanks to feedback from users like you. Please take a moment to read this quick start reference before using your new V16 radio.

-Helloradio Team.



Safety & Precautions.

Many radio control models are equipped with powerful motors and sharp spinning propellers. Please exercise caution when working on models. Ensure power is disconnected from your models and remove propellers when performing maintenance.

Do not operate the V16 radio system under the follow conditions.

- During bad weather or high wind conditions such as rain, hail, snow, storms or electromagnetic events.
- Under limited visibility.
- In areas where people, property, powerlines, roads, vehicles or animals may be in present.
- If you are feeling tired or unwell or under the influence of drugs or alcohol.
- If the radio or model appear to be damaged or not functioning correctly.
- In areas of high 2.4GHz interference or in locations where use of 2.4GHz radios is prohibited.
- When the battery in the V16 or the model is too low to function.



Manuals and firmware downloads.

The V16 is shipped with EdgeTX software installed as standard. To download the latest software and manual please visit <https://www.helloradiorc.com>

Further firmware information.

EdgeTX: <http://edgetx.org>

OpenTX: www.opentx.org

ExpressLRS: <https://www.expresslrs.org/2.0/>

Multi Protocol Module: <https://www.multi-module.org/>



CAUTION!

The V16 is shipped with the most stable firmware at the time of manufacture. Please only update firmware if you are experienced and confident in updating system firmware. Incorrect updates may render the radio inoperable.

DO NOT charge 6.6v LiFe battery packs or Li-ion 18650 cells with nominal voltage of 3.6v. Incorrectly charging the wrong battery type may lead to damage of the radio or fire.

Antenna Separation Distance

When operating your Helloradio transmitter, please be sure to maintain a separation distance of at least 20 cm between your body (excluding fingers, hands, wrists, ankles and feet) and the antenna to meet RF exposure safety requirements as determined by FCC regulations.

Regularly check the health and condition of your batteries and never leave your radio charging unattended. Always charge in a safe area away from combustible materials and surfaces. Do not charge if your radio becomes wet or damaged in any way. Helloradio does not accept any liability for the use or misuses of this product.



Remote control overview

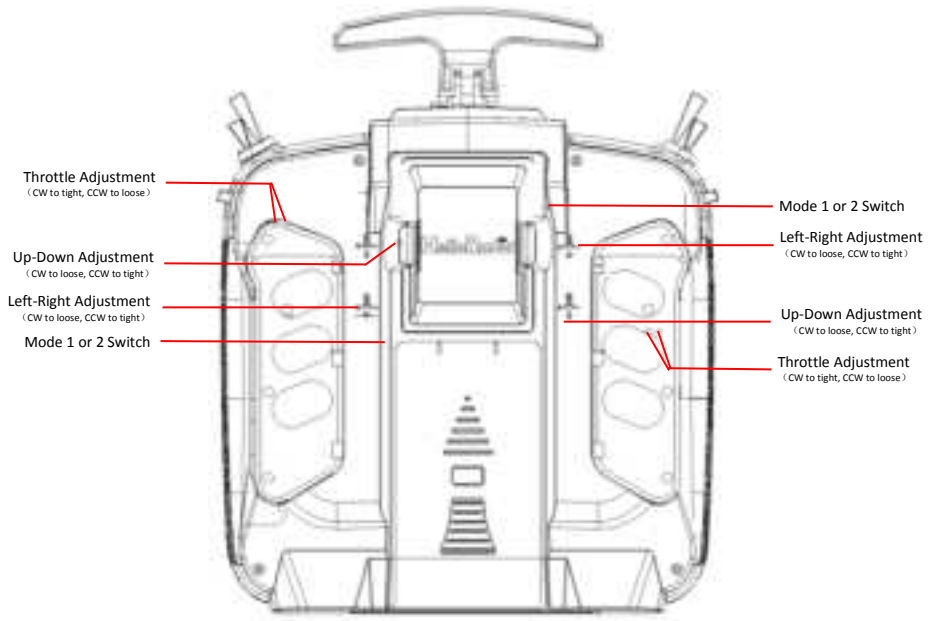
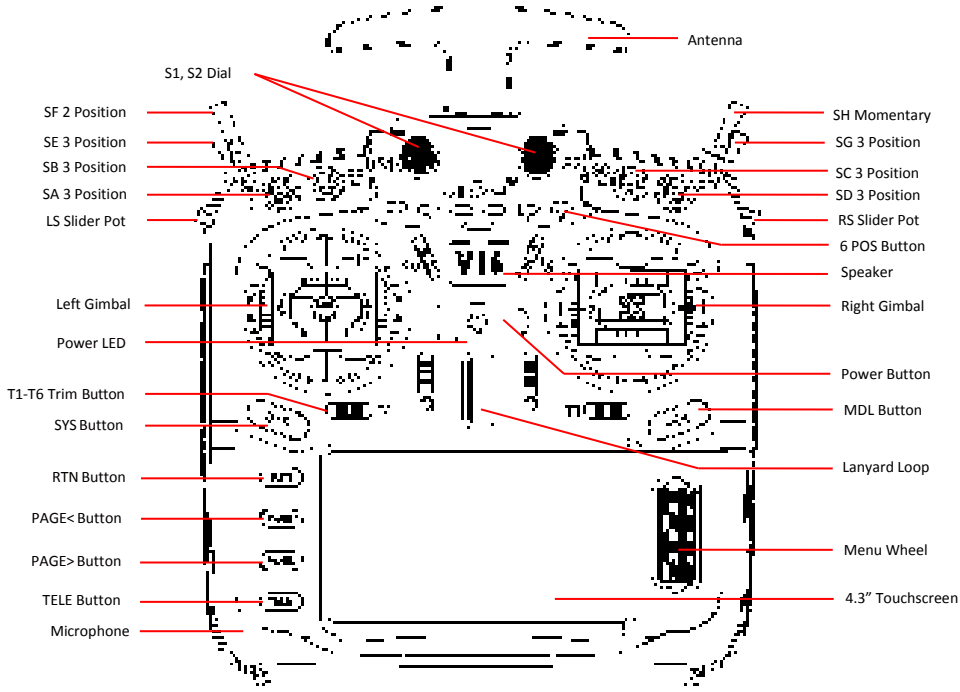

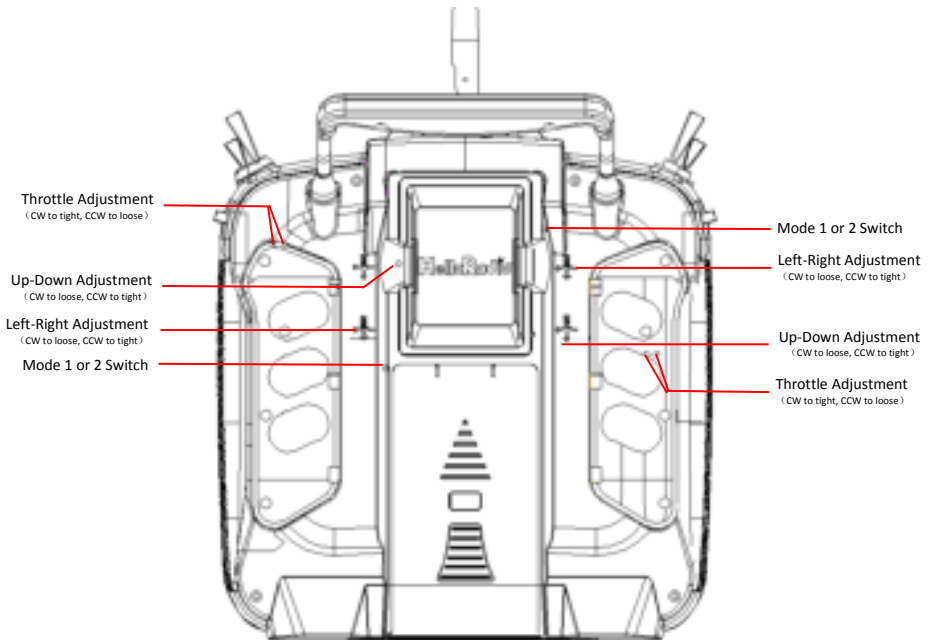
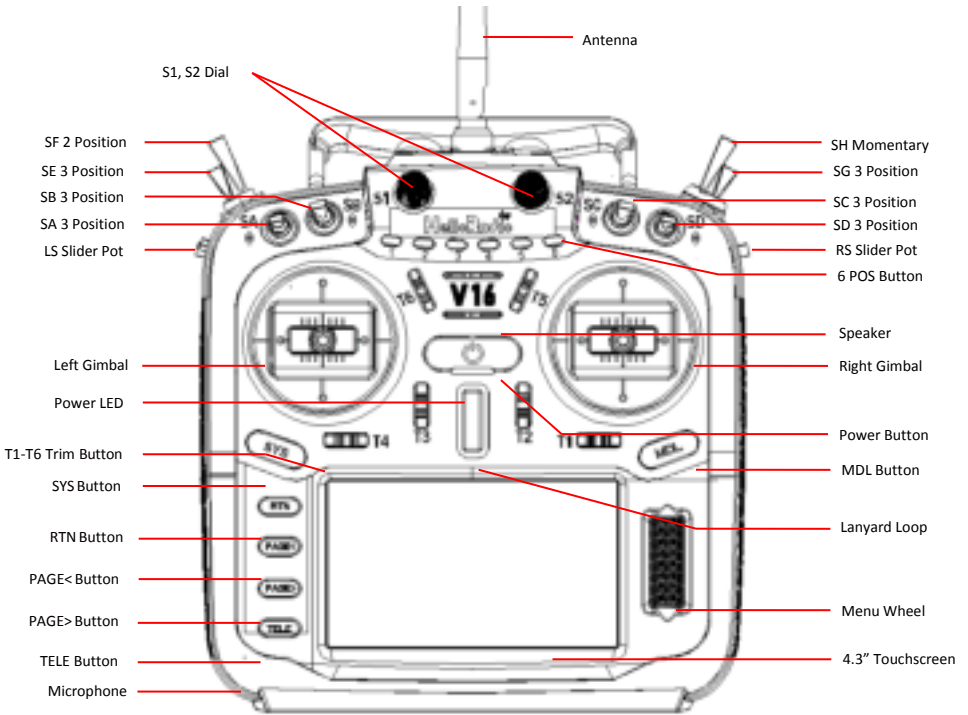

Power Requirements.

The V16 has built in USB-C charging for 3.7v Lithium cells. The Charging circuit is designed for 2x 3.7v Li-ion 18650 unprotected cells or 2x 3.7v Li-poly cells (2s 7.4v LiPO pack) only with a nominal cell voltage of 3.7v and maximum charge capacity of 4.2v.

Model and protocol selection (multi-protocol module)

A wide variety of modules is available for V16 units with the 4-in-1 module. To find out whether a certain protocol would work with your radio, please visit: <https://www.multi-module.org/>

Please note that current protocols may be updated, and new protocols added, without prior notice.



Press and hold the MDL button and scroll to the MODEL SETUP page. Under internal RF, set the Mode to MULTI and select the RF Protocol/ sub protocol as desired. Once the protocol is selected, the corresponding RF chip will be activated.

Note:

- The Bind button starts the bind process, if a compatible receiver is in bind mode within range, it will bind to your receiver.
- Range mode cuts the RF output by a factor of 30, allowing for easy range testing.

Model and protocol selection (ELRS)

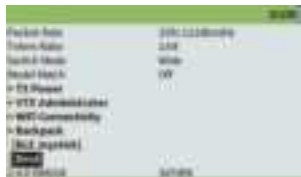
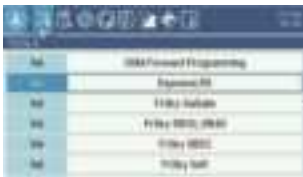

Bind method :

1. Turn off the radio.
2. Cycle power to the receiver 3 times, the receiver LED will start blinking, indicating it's in bind mode.
3. Turn on the radio, enter the ExpressLRS LUA, and select Bind.
4. The receiver LED will now stay illuminated, signaling a successful bind process.

Support.

Warranty and Repairs.

Please retain your proof of purchase and contact the retailer you purchased your V16 from, should you experience any problems with your radio hardware. Warranty is valid for one year from the date of purchase.



Specifications

Size: 286*128*182mm
 Weight: 750g (without battery)
 Transmission frequency: 2.400GHz-2.480GHz
 Transmitter module: 4-in-1 multi-protocol internal module -OR- ExpressLRS internal module
 Working current: 450mA
 Working voltage: 6.6-8.4vDC
 Radio firmware: EdgeTX (Supports OpenTX also)
 Channels: Up to 16 channels (depending on the receiver)
 Display: 4.3-inch TFT full-color touch display with a resolution of 480 * 272
 Gimbal: V4.0 Hall sensor with Aluminum fascia -OR- AG01 CNC Hall sensor
 Module Bay: JR compatible module bay
 Upgrade method: Supports USB-C online / SD card offline upgrade



Approved for use

2 x 3.7v Li-ION 18650 cells (7.4v using supplied tray)
 2 x 3.7v Li-ION 21700 cells (Assembled as 7.4v 2s Battery pack)
 2 x 3.7v Lithium-polymer cells (Assembled as 7.4v 2s Battery pack)



DO NOT use
 3.6v Li-ION cells
 2S 6.6v LiFE Battery packs
 LiFEP04 cells



Do not use 2s 6.6v LiFE battery pack, 18650 lithium-ion cells with a nominal voltage of 3.6v or LiFEP04 18650 Round cells. Using the built in USB charger with incorrect battery types and voltage may cause damage to the remote control or fire.

Check the health and condition of the batteries regularly. Do not use damaged cells. Never charge your device unattended. Always charge in a safe area away from flammable materials. If the remote control gets wet or damaged in any way, do not charge it.

Helloradio is not responsible for any adverse consequences caused by using or misusing this device.



EU Simple Declaration of Conformity

Helloradio declares the radio equipment V16 is in compliance with EU directives Directive 2014/53/EU. Full text of the declaration of conformity is available at the following website www.radio-masterrc.com

Manufactured by

ShenZhen Helloradio Co., Ltd



FCC statement

This equipment has been tested and found to comply with the limits for a Class B digital device, pursuant to Part 15 of the FCC Rules. These limits are designed to provide reasonable protection against harmful interference in a residential installation. This equipment generates uses and can radiate radio frequency energy and, if not installed and used in accordance with the instructions, may cause harmful interference to radio communications. However, there is no guarantee that interference will not occur in a particular installation. If this equipment does cause harmful interference to radio or television reception, which can be determined by turning the equipment off and on, the user is encouraged to try to correct the interference by one or more of the following measures:

- Reorient or relocate the receiving antenna.
- Increase the separation between the equipment and receiver.
- Connect the equipment into an outlet on a circuit different from that to which the receiver is connected.
- Consult the dealer or an experienced radio/TV technician for help.

This device complies with part 15 of the FCC Rules. Operation is subject to the following two conditions:

(1) This device may not cause harmful interference, and (2) this device must accept any interference received, including interference that may cause undesired operation.

Changes or modifications not expressly approved by the party responsible for compliance could void the user's authority to operate the equipment.

Full text of the declaration of conformity is available at the following website
www.helloradiorc.com



CAUTION:

Changes or modifications not expressly approved by the party responsible for compliance could void the user's authority to operate the equipment. This product contains a radio transmitter with wireless technology which has been tested and found to be compliant with the applicable regulations governing a radio transmitter in the 2.400GHz to 2.4835GHz frequency range.



简介

感谢您购买 Helloradio V16 2.4g 遥控系统。该系统用途广泛，可供初学者和专业人士使用。为了确保正确、安全地使用本产品，请在使用前仔细阅读本使用说明书。由于版本升级，已经进行了更改。本手册中包含的信息如有更改，恕不另行通知。V16 遥控器适用于所有类型的固定翼、滑翔机、直升机和多旋翼飞机。可以根据使用的航空器选择型号类型，并可以使用各种混合功能。

-Helloradio 团队敬上。



安全须知

许多遥控模型都配备了强大的电机和锋利的螺旋桨。使用模型时，请谨慎行事。进行组装或维护时，请确保已断开模型的电源并卸下螺旋桨。

在以下情况下，请勿操作 V16 遥控系统：

- 在恶劣天气或强风条件下，例如雨，冰雹，下雪，暴风雨或电磁环境中。
- 在能见度有限的任何情况下。
- 在可能存在人员、财产、电力高压线、公共道路、有车辆或动物的区域。
- 如果您感到疲倦或不适，或在药物或酒精的影响下。
- 如果遥控器或模型似乎已损坏或无法正常工作。
- 在 2.4GHz 干扰较大的区域或禁止使用 2.4GHz 无线电的地方。
- 当电池电压太低而无法使用时。
- 在当地法规禁止使用航空模型的区域。



说明书和固件下载

V16 预装标准的 EdgeTX 固件。要下载最新的软件手册，请访问 Helloradio 网站：

<https://www.helloradiorc.com>

EdgeTX: <http://edgetx.org>

OpenTX: www.opentx.org

ExpressLRS: <https://www.expresslrs.org/2.0/>

Multi Protocol Module: <https://www.multi-module.org/>



警告！

V16 出厂时预装最稳定的固件。如果您有经验并且有信心更新系统固件，请仅更新固件。不正确的更新可能会导致遥控器无法操作。

未经负责合规方明确批准的更改或修改可能会使用户丧失操作设备的权限。本产品包含具有天线技术的无线电发射器，该无线电发射器已经过测试，符合适用于 2.400GHz 至 2.4835GHz 频率范围内的无线电发射器的适用法规。

安全的天线距离

操作 Helloradio 发射器时，请确保您的身体（不包括手指，手，腕，脚踝和脚）与天线之间保持至少 20cm 的距离，以符合 FCC 法规确定的 RF 暴露安全要求。



电源和充电注意事项

V16 内置 USB 充电功能，支持 2cell 7.4v 电池组 (2 x 3.7v 锂电池组)。充电电路仅适用于 2x 3.7v 锂离子 18650、2x 21700 3.7v 锂离子 (21700 2s 7.4v 锂离子电池组) 或 2x 3.7v 锂聚合物 (2s 7.4v 锂聚合物电池组)。每个电池的标称电压为 3.7v，最大充电截止电压为 4.2v。



遥控器概述

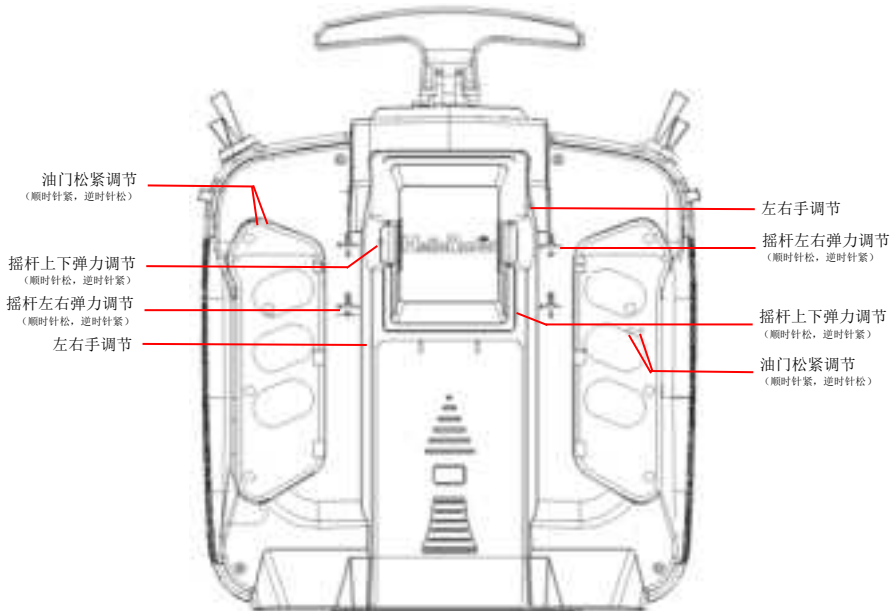
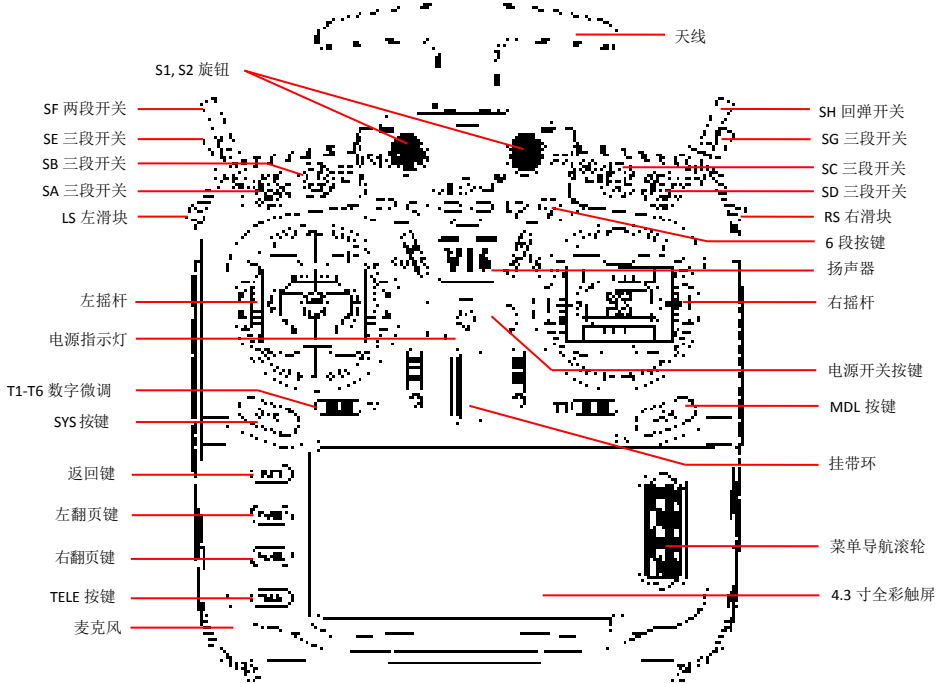

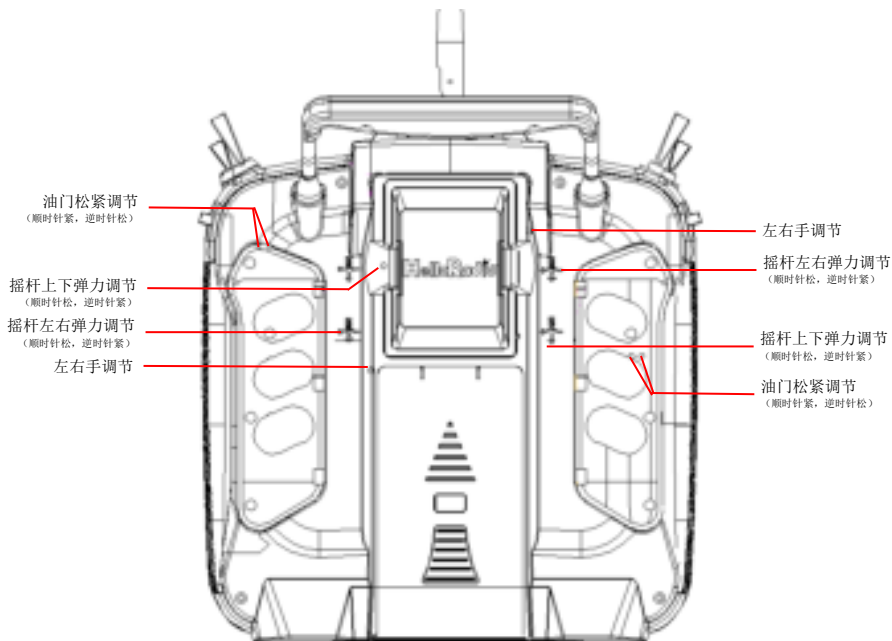
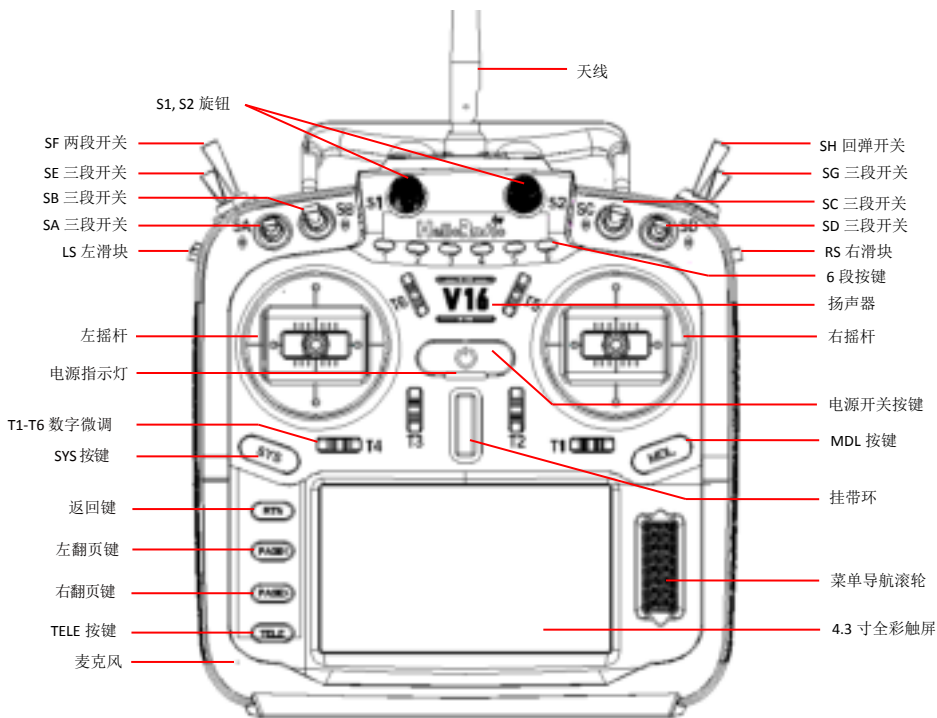



模型选择及协议选择（多协议）

V16 附带四合一多协议高频模块，拥有并兼容很多不同协议，要查看所有兼容协议的最新列表，请访问：<https://www.multi-module.org/>。
请注意，新协议会不断更新并被添加到最新固件。



请长按 MDL 按钮进入模型设置，在 MODEL SETUP 页面中选择 MULTI，并在子选项中选择需要使用的协议。系统根据您选择的射频协议，会自动开启对应的射频模块，同时关闭其它三个射频模块。系统在同一时间只会开启一个射频模块，以确保没有多余的无线电信号相互干扰。

- Bind 按钮用于启动对频过程。
- Range 按钮可将功率降低至 1/30，以方便测试遥控距离。



模型选择及协议选择（ExpressLRS）

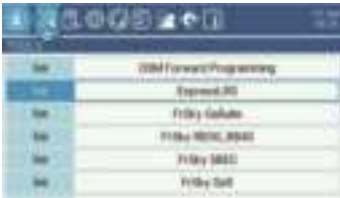

对频方法：

- 1: 关闭遥控器
- 2: 重复给接收机上电三次，接收机灯双闪，表明接收机处于对频模式
- 3: 开启遥控器，进入 ELRS 的 LUA 操作界面，选择到【BIND】，确认
- 4: 接收机灯常亮表明对频成功



注意

EdgeTX 软件非常强大，并且具有大量的编程和混控功能。请从下面的链接下载综合软件安装指南以获取更详细的说明：<https://www.EdgeTx.org>



保修及维修

如果您的遥控器硬件出现任何问题，请保留购买证明并与您购买 V16 的零售商联系。

固件更新和 EdgeTX 信息

有关 EdgeTX 开源软件开发团队最新资讯和固件更新，请访问 EdgeTX 网站，网址为 <https://www.open-tx.org>。

用户手册

有关 V16 EdgeTX 系统固件的详细用户手册，请访问 <https://www.EdgeTx.org>。



技术指标

规格尺寸：286*128*182 毫米 重量：
750 克（不含电池）

传输频率：2.400GHz-2.480GHz

发射器模块：四合一多协议高频模块（CC2500 CYRF6936 A7105 NRF2401）
ExpressLRS 高频模块(ELRS)、（四合一或 ELRS 模块视硬件版本而定）

工作电流：450mA

工作电压：6.6-8.4v DC

开源固件：EdgeTX（遥控器）

通道数：最多 16 个通道（取决于接收器）

显示：4.3 英寸 TFT 全彩显示屏，分辨率为 480 * 272

云台：非接触式 3D 矢量霍尔操纵杆 JR/FrSKY 兼容模块托架

升级方法：支持 USB 在线/SD 卡离线升级

协议：全系列 DSM2/X 全系列 Flysky 和 Flysky 2A FrSKY

（有关完整协议列表，请访问

https://github.com/pascallanger/DIY-Multiprotocol-TX-Module/blob/master/Protocols_Details.md）



允许使用的电池规格

2 x 3.7v Li-ION 18650 电池组（7.4v 随遥控器附带的电池盒）

2 x 3.7v Li-ION 21700 cells（7.4v 2s 电池组）

2 x 3.7v Lithium-polymer cells（7.4v 2s 电池组）



请勿使用以下电池或电池组

3.5 v Li-ION 电池

2S 6.6v LiFE 电池组

LiFEP04 电池组



特别警告

请勿使用 2S 6.6v LiFE 电池组，标称电压为 3.6v 的 18650 锂离子电池或 LiFEP04 18650 圆形电池。如果使用错误的电池类型和电压，在使用内置的 USB 充电器充电时，可能会损坏遥控器或引起火灾。

请定期检查电池的电压和状况，决不要在无人看守的情况下为其充电。请务必始终在远离可燃材料的安全区域中充电。如果遥控器弄湿或以任何形式损坏，请勿充电。

对于不按照安全规范使用或滥用本产品造成的一切不良后果，Helloradio 不承担任何责任。



欧盟认证合格声明

Helloradio 无线电设备 V16 符合欧盟指令 2014/53/EU。符合性认证声明的全文可在以下网站上找到：www.helloradiorc.com

制造商

深圳 Helloradio 有限公司



FCC 认证信息

该设备已经过测试，符合 FCC 规则第 15 章的规定。操作必须符合以下两个条件：

(1) 此设备不会造成有害干扰

(2) 此设备必须接受收到的任何干扰，包括可能导致意外操作的干扰。符合性声明的全文可在以下网站上找到：www.helloradiorc.com

WWW.HELLORADIORC.COM