



CAR710-4

QUICK START GUIDE

Media Receiver with Android Auto™ and Apple CarPlay®
featuring a 7" digital TFT Display



This Quick Start Guide gives you the basics to start using your CAR710-4. Please visit <https://www.jensenmobile.com>. to download a complete owner's manual or call customer service at 1-888-921-4088 (Monday-Friday, 9AM-5PM EST).

Designed and Engineered in USA

JENSEN®

Installation

Before You Start

- Disconnect negative battery terminal. Consult a qualified technician for instructions.
- Avoid installing the unit where it would be subject to high temperatures, such as from direct sunlight, or where it would be subject to dust, dirt or excessive vibration.

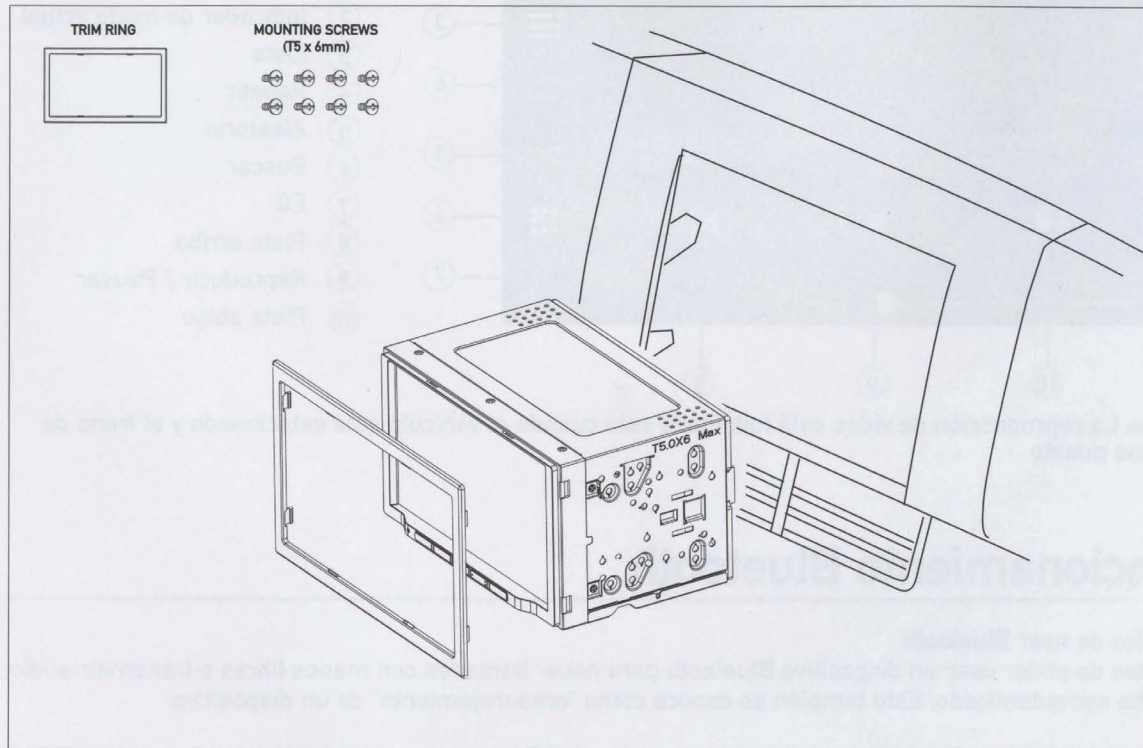

* Use 2 or 3 screws to affix the monitor to the bracket.

Control Locations



The radio display features the following functions and displays:

- | | |
|--------------|---------------------------|
| ① RESET | ⑤ SOURCE |
| ② VOL- | ⑥ VOICE ACTIVATION BUTTON |
| ③ VOL+ | |
| ④ Power/Mute | |

Wiring Diagram - Inputs/Outputs

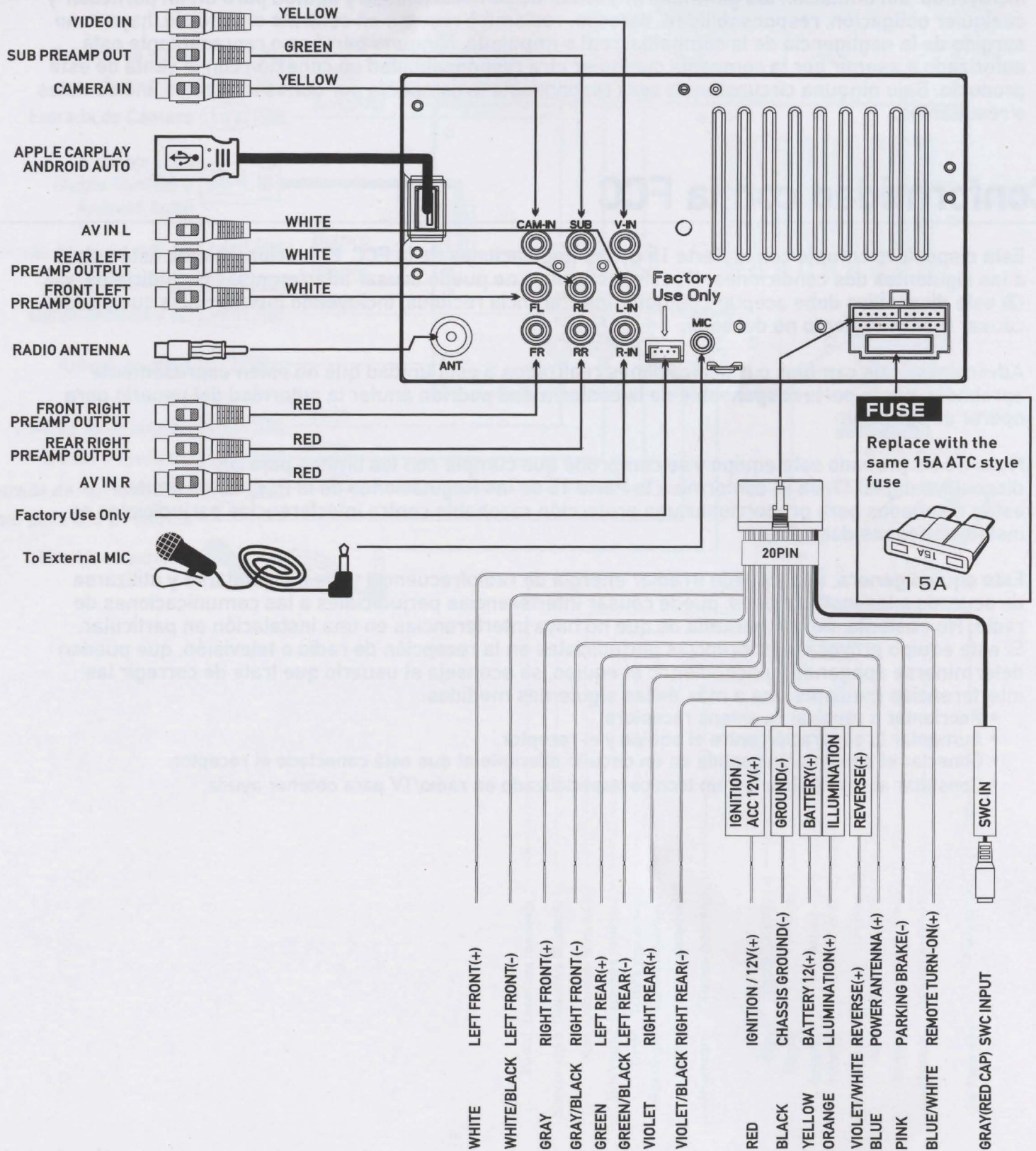

Note:

When replacing a fuse, make sure to use the correct type and amperage. Using an incorrect fuse could cause damage. The unit uses (1) 15 amp ATC mini style fuse located on the power connector.

Wiring Notes:

Subwoofer output

The Subwoofer preamp audio output (Green RCA) is active in all audio modes.

Rear camera input

A rear view camera (not included) can be used with the Camera input.

Main Menu

In main menu, press the desired icon to enter the corresponding mode: Radio/USB/BT Phone/BT Audio/Android Auto/Apple CarPlay/AV In/Equalizer/Settings.



Tuner Operation

The screenshot shows the 'Radio' tuner operation screen. At the top, it displays 'Radio' and '12:26 AM'. Below this, there are six preset stations: 1 107.7, 2 90.1, 3 98.1, 4 106.1, 5 107.9, and 6 87.5. A large display shows the current frequency '107.7 MHz' with 'Seek Tune Up' and 'Seek Tune Down' buttons. At the bottom, there are two mode buttons: 'FM1' and 'AM1'. On the right side, there are two vertical panels: 'DX' and 'EQ'. The 'DX' panel has a signal strength indicator. The 'EQ' panel has an equalizer icon.

- ① Main Menu
- ② Current Mode Indicator
- ③ Preset Stations
- ④ Local/Distance
- ⑤ AS/PS
- ⑥ Keypad
- ⑦ EQ
- ⑧ Seek Tune Up
- ⑨ Seek Tune Down
- ⑩ AM
- ⑪ FM

USB Operation

From the main menu, touch the USB icon on the main screen.



Note: Video playback is enabled only when the vehicle is in park and the parking brake engaged.

Bluetooth Operation

Before using Bluetooth

Before you can use a Bluetooth device to make hands-free calls or stream audio, it must be authenticated. This is also referred to as "pairing" a device.

Pairing a New Device

The unit broadcasts the pairing signal constantly when no devices are currently connected. Complete the pairing sequence from your Bluetooth device. Refer to the owner's manual for your device for more details. **The device name is "CAR710-4".** The unit can be in any mode of operation when pairing is performed. On certain phones, pairing may need to be done more than once.

Connect

The head unit will automatically connect to the last connected device when the connect feature is set to Auto connect On. If the connect feature is set to Auto Connect Off, the head unit will not automatically connect to any device.

Bluetooth Phone

From the main menu, touch the **Bluetooth** on the screen. Bluetooth icon will appear anytime a Bluetooth device is connected.

Dialing a Number

Press to display keypad and dial a number.

Making and Ending a Call

Press to connect a call, and press to end a call.

Transferring Audio

Press to transfer audio between the head unit and mobile phone.

Streaming Audio

Press to play or pause the music.

Press to skip to the previous track.

Press to advance to the next track.

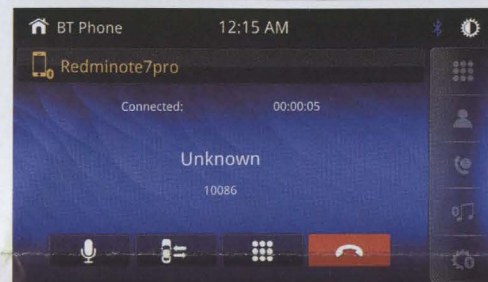
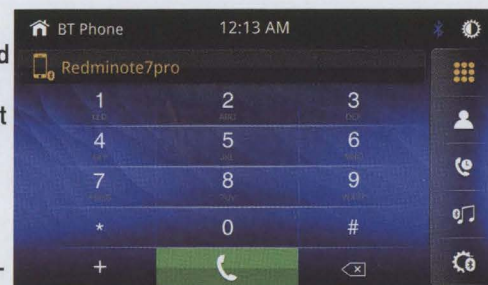

Audio Operation

Press the Settings icon on the main menu screen to adjust Fader and Balance controls, Equalizer (8-Band Tone Control and 8 Presets EQ Settings).

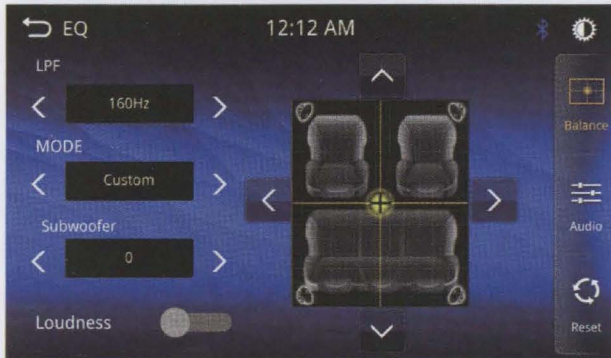

Apple CarPlay Operation

Select Apple CarPlay on the Main Menu.

If the iPhone is connected via USB port, press Apple CarPlay icon on main menu to mirror the iPhone's apps onto the screen. If the iPhone USB cable is inserted to the USB port then the CAR710-4 will automatically change to Apple CarPlay mode.

Please refer to on-line Owner's Manual for more details.

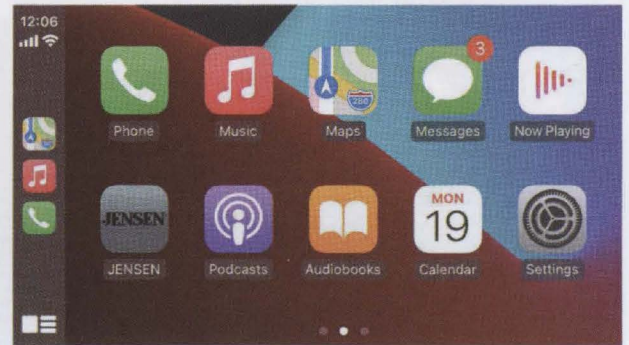

Android Auto™ Operation

Select Android Auto on the Main Menu.

If the Android Phone is connected via USB port, press Android Auto icon on main menu to mirror the Android Auto Basic Image onto the screen. If the Android Phone USB cable is inserted to the USB port then the CAR710-4 will automatically change to Android Auto mode.

Please refer to on-line Owner's Manual for more details.

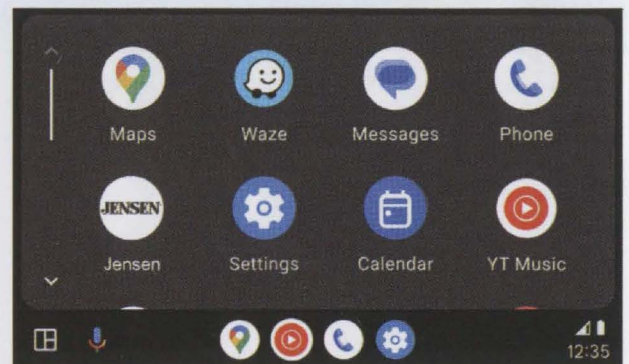

General Operation

From the Main Menu screen, select Setup to access the Settings menu and select from categories represented by the icons on the right of the screen: General, Audio, Display, Others. Select the category, and adjust any of the available options using the touch screen.

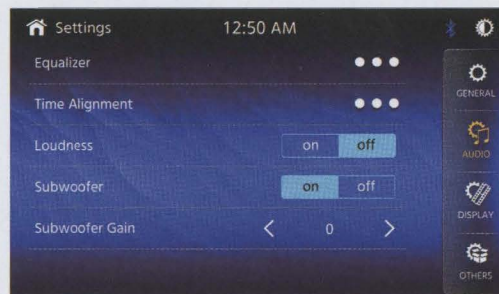
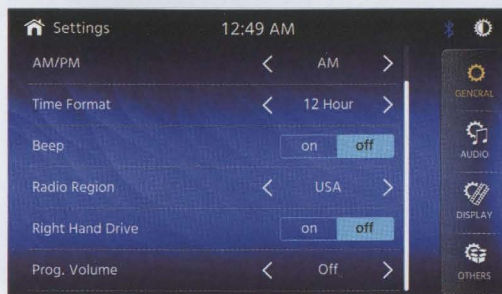

Limited One Year (Or Three Year*) Warranty

This warranty gives you specific legal rights. You may also have other rights which vary from state to state. Namsung America Inc warrants this product to the original purchaser to be free from defects in material and workmanship for a period of one year (or three years*) from the date of the original purchase. Namsung America Inc agrees, at our option, during the warranty period, to repair any defect in material or workmanship or to furnish an equal new, renewed or comparable product (whichever is deemed necessary) in exchange without charges, subject to verification of the defect or malfunction and proof of the date of purchase. Subsequent replacement products are warranted for the balance of the original warranty period.

Who is covered? This warranty is extended to the original retail purchaser for products purchased from an authorized JENSEN dealer and used in the U.S.A.

What is covered? This warranty covers all defects in material and workmanship in this product. The following are not covered: software, installation/removal costs, damage resulting from accident, misuse, abuse, neglect, product modification, improper installation, incorrect line voltage, unauthorized repair or failure to follow instructions supplied with the product, or damage occurring during return shipment of the product. Specific license conditions and copyright notices for the software can be found via www.jensenmobile.com.

Warranty Coverage

Limited 1-year warranty when purchased from an authorized Jensen dealer.

or

*Limited 3-year warranty when purchased from and professionally installed by an authorized Jensen dealer. (Proof of purchase and Installation required)

What to do?

1. Before you call for service, check the troubleshooting guide in your owner's manual. A slight adjustment of any custom controls may save you a service call.
2. If you require service during the warranty period, you must carefully pack the product (preferably in the original package) and ship it by prepaid transportation with a copy of the original receipt from the retailer to an authorized service center.
3. Please describe your problem in writing and include your name, a return UPS shipping address (P.O. Box not acceptable), and a daytime phone number with your shipment.
4. For more information and for the location of the nearest authorized service center please contact us by one of the following methods:
 - Call us toll-free at (888) 921-4088 (Monday-Friday, 9:00 a.m. to 5:00 p.m. EST)
 - E-mail us at cs@jensenmobile.com

Exclusion of Certain Damages: This warranty is exclusive and in lieu of any and all other warranties, expressed or implied, including without limitation the implied warranties of merchantability and fitness for a particular purpose and any obligation, liability, right, claim or remedy in contract or tort, whether or not arising from the company's negligence, actual or imputed. No person or representative is authorized to assume for the company any other liability in connection with the sale of this product. In no event shall the company be liable for indirect, incidental or consequential damages.

FCC Compliance

This device complies with Part 15 of the FCC Rules. Operation is subject to the following two conditions:

- (1) this device may not cause harmful interference, and
- (2) this device must accept any interference received, including interference that may cause undesired operation.

Warning: Changes or modifications to this unit not expressly approved by the party responsible for compliance could void the user's authority to operate the equipment.

Note: This equipment has been tested and found to comply with the limits for a Class B digital device, pursuant to Part 15 of the FCC Rules. These limits are designed to provide reasonable protection against harmful interference in a residential installation. This equipment generates, uses and can radiate radio frequency energy and, if not installed and used in accordance with the instructions, may cause harmful interference to radio communications. However, there is no guarantee that interference will not occur in a particular installation. If this equipment does cause harmful interference to radio or television reception, which can be determined by turning the equipment off and on, the user is encouraged to try to correct the interference by one or more of the following measures:

- Reorient or relocate the receiving antenna.
- Increase the separation between the equipment and receiver.
- Connect the equipment into an outlet on a circuit different from that to which the receiver is connected.
- Consult the dealer or an experienced radio/TV technician for help.

www.jensenmobile.com

©2024 Namsung America Inc. All rights reserved.

NSC0124-V02

Register your warranty



Scan to register, or visit:

<https://jensenmobile.com/register.html>

Upon registration you may also choose to be notified of product updates or special promotions.

Visit www.jensenmobile.com for detailed owner's manuals on most products.

If you need any assistance, please contact customer service at cs@jensenmobile.com or call [1-888-921-4088](tel:1-888-921-4088) M-F 9 am - 5 pm ET

Thank you for your purchase!

JENSEN®

[**www.JensenMobile.com**](http://www.JensenMobile.com)

Follow us to keep up to date with new products and information!

Facebook

@JensenAudio

Instagram

@JensenAudio

Twitter

@JensenAudio

BUCAM350

Universal License Plate
Style Camera

What's in the box

1. Product Sheet
2. BUCAM350 License plate style camera
3. Power Cable w/ Fuse, Video Cable



Mounting the camera

Position on the license plate top screws for the best viewing angle. This should not be directly next to or under a reverse/backup/license lamp as it may blind the camera at night. Before drilling, determine the best way to run the power wires to the reverse lights and the extension cable through the car. Insure that the route will not interfere with any safety equipment, trunk release or other items in the vehicle. Look for wires, sensors, double metal, anything that could cause a problem or damage. The camera should lay flat against the mounting surface for proper installation.

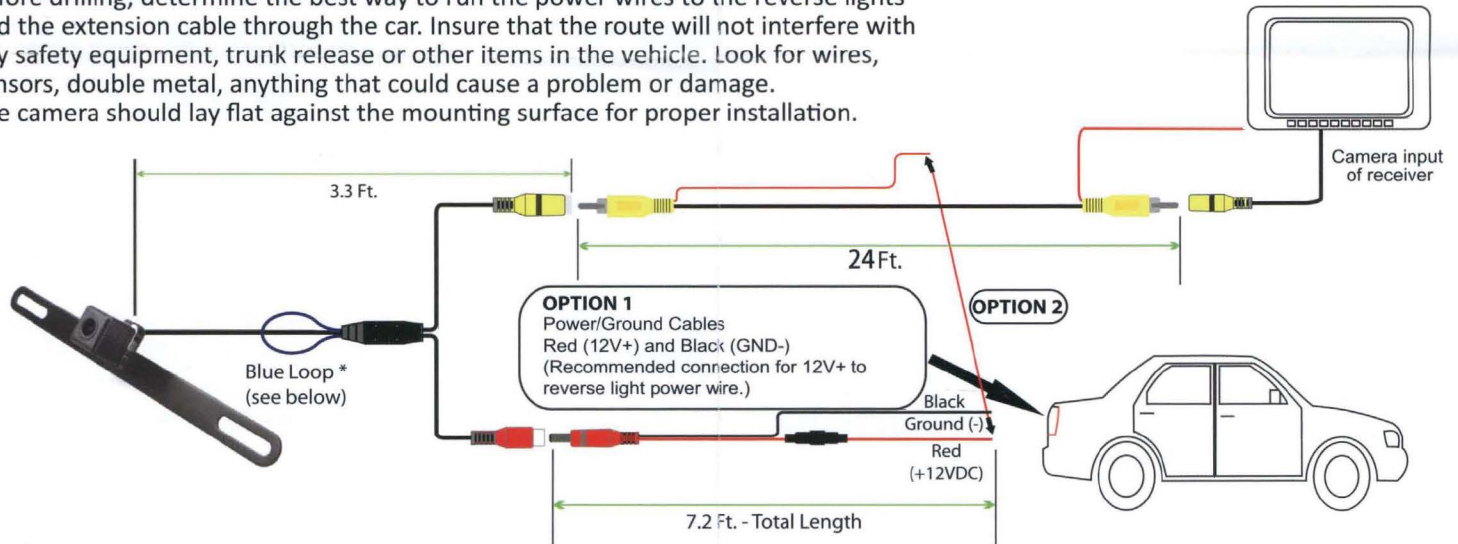

1. Fix the camera to the appropriate position on the license plate and adjust the angle .
2. Follow ONE of the following wiring options.

OPTION 1: Connect camera power wire to the vehicle's reverse lamp:

- a) Locate the reverse lamp in the tail light assembly.
- b) Attach the red wire to the positive 12 volt wire from the reverse lamp. Use a crimp connector or soldering tool to ensure connection is secure. Once this connection is complete, note that the red power wire that is located on either end of the video RCA cable will not be needed. The bare wire at the end of each wire lead should be capped or taped off to prevent potential power interruption.
- c) Attach the black wire to ground(-).
- d) Run video cable to the location of the receiver or monitor(not included). Connect one yellow RCA end of the video cable to the camera and connect the other end of the yellow RCA cable to the video source(receiver/monitor).

OPTION 2: Connect camera power wire to receiver/monitor power:

- a) From camera location, connect red power wire from power cable to red power wire from one end of the video cable. Use a crimp connector or soldering tool to ensure connection is secure.
- b) Attach the black wire to ground.
- c) Run video cable to the location of the receiver or monitor(not included). Connect not yellow RCA end of the video cable to the camera and connect the other end of the yellow RCA cable to the video source(receiver/monitor).
- d) From video source(receiver/monitor) location, connect red power wire from end of the video cable to the reverse wire lead located on the video source(receiver/monitor).

Camera Specifications

Image Sensor: CMOS, OV 7955
Power: 12V DC, Negative Ground
Power Consumption: < 1 Watt
Effective Pixels: 672H x 492V
Video Format: NTSC
Lux: < 0.5
White Balance: Auto
Viewing Angle: 170 Degrees
IP Rating: IP67
Operating Temperature: -30°C ~ +70°C
Plate material: Stainless Steel SUS304
Camera Body: Plastic

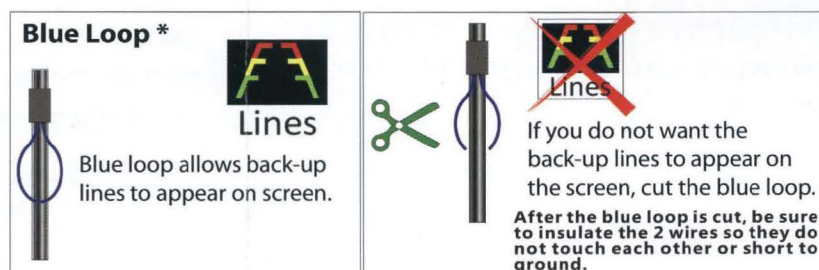

Limited One Year Warranty

This warranty gives you specific legal rights. You may also have other rights which vary from state to state.

Dual Electronics Corp. warrants this product to the original purchaser to be free from defects in material and workmanship for a period of 1(one) year from the date of the original purchase.

Dual Electronics Corp. agrees, at our option, during the warranty period, to repair any defect in material or workmanship or to furnish an equal new, renewed or comparable product (whichever is deemed necessary) in exchange without charges, subject to verification of the defect or malfunction and proof of the date of purchase.

Subsequent replacement products are warranted for the balance of the original warranty period.

Who is covered? This warranty is extended to the original retail purchaser for products purchased from an authorized Jensen / Dual or Axxera dealer and used in the U.S.A.

What is covered? This warranty covers all defects in material and workmanship in this product. The following are not covered: software, installation/removal costs, damage resulting from accident, misuse, abuse, neglect, product modification, improper installation, incorrect

line voltage, unauthorized repair or failure to follow instructions supplied with the product, or damage occurring during return shipment of the product. Specific license conditions and copyright notices for the software can be found via www.dualav.com.

What to do?

1. Before you call for service, check the troubleshooting guide in your owner's manual. A slight adjustment of any custom controls may save you a service call.
2. If you require service during the warranty period, you must carefully pack the product (preferably in the original package) and ship it by prepaid transportation with a copy of the original receipt from the retailer to an authorized service center.
3. Please describe your problem in writing and include your name, a return UPS shipping address (P.O.Box not acceptable), and a daytime phone number with your shipment.
4. For more information and for the location of the nearest authorized service center please contact us by one of the following methods:

- Call us toll-free at 1-866-382-5476
- E-mail us at cs@dualav.com

Exclusion of Certain Damages: This warranty is exclusive and in lieu of any and all other warranties, expressed or implied, including without limitation the implied warranties of merchantability and fitness for a particular purpose and any obligation, liability, right, claim or remedy in contract or tort, whether or not arising

from the company's negligence, actual or imputed. No person or representative is authorized to assume, for the company, any other liability in connection with the sale of this product. In no event shall the company be liable for indirect, incidental or consequential damages.