



JK Audio AutoHybrid IP2 VoIP/AoIP Codec User Guide

[Home](#) » [JK Audio](#) » JK Audio AutoHybrid IP2 VoIP/AoIP Codec User Guide 

Contents

- [1 JK Audio AutoHybrid IP2 VoIP/AoIP Codec](#)
- [2 Limited Warranty](#)
- [3 Features](#)
- [4 What's in the Box](#)
- [5 Introducing the AutoHybrid IP2™](#)
- [6 Getting to Know Your AutoHybrid IP2](#)
- [7 Controls & Indicators](#)
- [8 Inputs & Outputs](#)
- [9 Getting Connected](#)
- [10 Before Logging In](#)
- [11 Graphic User Interface](#)
- [12 Call Management](#)
- [13 Accounts](#)
 - [13.1 General](#)
- [14 Network / System](#)
 - [14.1 WAN Settings](#)
 - [14.2 VLAN Settings](#)
 - [14.3 Identification](#)
- [15 Management](#)
 - [15.1 Configure](#)
 - [15.2 Reboot/Restore](#)
- [16 FAQs](#)
- [17 Troubleshooting](#)
- [18 Block Diagram](#)
- [19 Technical Information](#)
- [20 FCC Compliance Notice](#)
- [21 Declaration of Conformity](#)
- [22 Documents / Resources](#)
 - [22.1 References](#)
- [23 Related Posts](#)

JK Audio



Welcome

Thank You

Thank you for purchasing a JK Audio AutoHybrid IP2 VoIP/AoIP Codec. Please read this guide for instructions on setting up and using your new product.

Getting Assistance

If you have technical or application questions: In the US & Canada, call us toll free at: 800-552-8346 All other countries dial: 815-786-2929 (M-F 8:30-5:00pm Central Time Zone) Email us at: support@jkaudio.com Or, check out our FAQ section for answers to common questions.

Limited Warranty

The AutoHybrid IP2 is covered by a 1 year warranty to be free from defective workmanship and materials. To obtain service, contact JK Audio by phone or email for return authorization. Once authorized, you will carefully pack and ship the faulty product and all accessories to us. You will pay for shipping to us and we will pay for return back to you. This warranty does not cover damages due to accident, weather, fire, flood, earthquake, misuse, unauthorized repairs or modifications, or damages occurred in shipping, only defective workmanship or materials. There are no expressed or implied warranties which extend beyond the warranty here made.

Features

- Simple 2-Line VoIP Call Control, Auto-Answer, and Conference
- Caller ID
- G.711, G.722 (HD Voice) VoIP Hybrid
- 24-bit AoIP Wide Band Stereo Codec
- AGC & Ducking
- Send and Receive LED Metering
- Female XLR Line Input (2)
- Male XLR Line Output (2)
- LAN, USB, Remote Control
- Connections
- Rear Panel Recessed Level Controls
- Remote Control I/O Terminal Block
- PoE or AC Mains Powered
- Optional RA2 Rack Mount Adapter

What's in the Box

- PS009 Power Supply
- CN094 AC cable

- CN114 Ethernet cable
- CN115 USB cable

Introducing the AutoHybrid IP2™

AutoHybrid IP2™ functions as a two-line VoIP hybrid. The desktop/half-rack design provides one button access to the common features of a phone line hybrid including: call control, auto-answer, and conference. Advanced call control features and VoIP line setup are provided through the internal web server. In VoIP mode, Line-level XLR jacks provide mono send and receive audio for Line 1 and Line 2. The AutoHybrid IP2™ Remote jack allows easy connection to the JK Audio Interchange™ Intercom Phone Bridge, offering an auto-answer VoIP connection into your party-line intercom. Low power consumption for Power over Ethernet (PoE) applications. External power supply included for LAN connections without PoE capability.

Ready to go?

The AutoHybrid IP2 controls and connectors are clearly marked and ready for operation. If this is your first exposure to a hybrid, we suggest that you read the entire manual to allow you to take advantage of all these features.

Any Questions?

Before you pick up the phone... Please thumb through the rest of this manual. You might find those deep technical questions are covered on later pages.

Product Registration / Firmware Updates

Your AutoHybrid IP2 contains many advanced features, but we are constantly looking for ways to improve. Product Registration allows us to keep you informed of any firmware updates that become available in the future. Please register your purchase by visiting: <http://www.jkaudio.com/support/>

Getting to Know Your AutoHybrid IP2

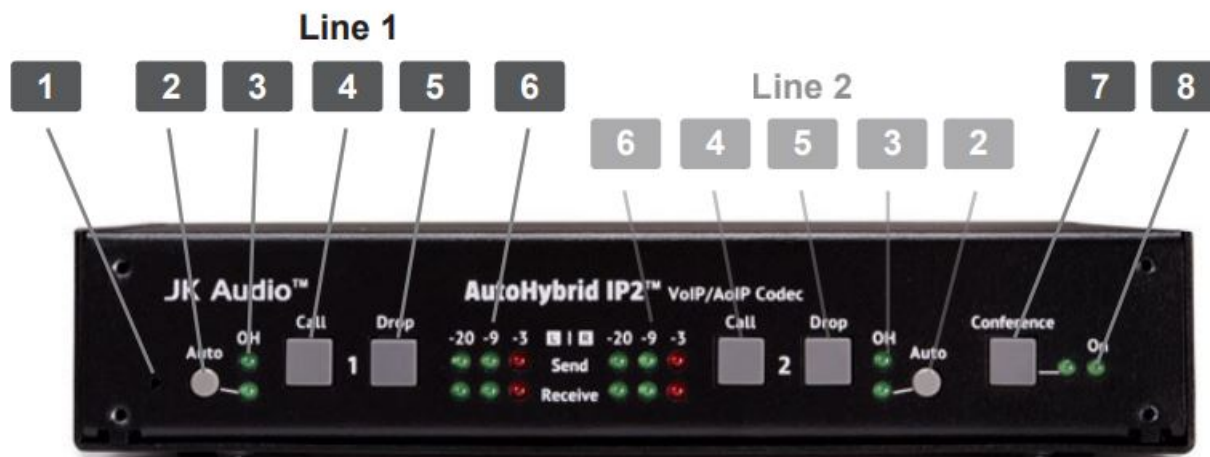

Controls & Indicators

Hidden Reset Switch

Use a paper clip to reset the AutoHybrid IP2 instead of power cycling.

Auto Answer

When enabled, AutoHybrid IP2 automatically answers an incoming call and then disconnects after the caller hangs up.

OH LED

Lit when the corresponding line is off-hook. For incoming calls, the OH LEDs provide a visual ring indication.

Call Buttons

Press this button to answer the corresponding line.

Drop Buttons

Press this button to drop a call or place the corresponding line on hook.

Signal LEDs

Send LEDs represent the signal level going into the transmitter. Receive LEDs represent the signal level at the output XLR.

Conference Button

Conference lines 1 & 2 together when both lines are off-hook. The LED will only light up when there are two calls in an active conference.

Power LED

Lit when unit receives power from AC or PoE.



Inputs & Outputs

Line Out 2/R

Line 2 or Stereo Right Channel male balanced XLR output with recessed level control.

Line In 2/R

Line 2 or Stereo Right Channel female balanced XLR input with recessed level control.

Line Out 1/L

Line 1 or Stereo Left Channel male balanced XLR output with recessed level control.

Line In 1/L

Line 1 or Stereo Left Channel female balanced XLR input with recessed level control.

LAN Jack

The LAN jack has a Link/Activity LED and 10/100 Mbps speed LED.

Remote Jack (For JK Audio products only)

WARNING! Connecting this jack to any device besides a JK Audio product may result in irreparable damage. This damage is not covered under warranty.

Remote Header

The removable screw terminal block provides connection to switch contacts for remote operation. See page 17 for the Remote Header Pinout.

USB Jack

Connecting the USB port to a computer is not necessary for typical operation. The USB port should only be used by your IT administrator to obtain the IP address or perform a “check file system” command.

Power Jack

For connection only to the supplied 9VDC regulated power supply.

Getting Connected

Setting Up

Although each application will require a slightly different setup, the following is a general cable connection setup and explanation.

1. Connect the supplied ethernet cable between the jack marked <LAN> and an active ethernet port.
2. Connect to your mixer.
 1. Connect a line-level audio signal to the AutoHybrid IP2 <Line In> jack(s).
 2. Connect the <Line Out> jack(s) to the line-level input(s) on your mixing console.
3. Connect the supplied AC power cord to the back of the AutoHybrid and then to an AC power outlet. Or, enable Power over Ethernet (PoE) on your switch or router.

Your AutoHybrid IP2 will be ready to take calls once a SIP Account is configured.

What is SIP?

Session Initiation Protocol. It is a standard communications protocol used for controlling multimedia communication sessions. For public service outside of your local network, users must register with a VoIP provider which provides a directory service similar to a public switched telephone network for POTS lines. The AutoHybrid IP2 protocol stack provides the components necessary to provide a standardized method for managing the device, providing real-time multimedia transport and monitoring and controlling the Quality of Service. SIP is a standard mechanism for connection management, including registration and location service, that provides phone number portability across the internet.

Before Logging In

To log into the AH IP2 GUI you will have to enter the IP address in your browser's address bar. There are a few methods of finding a dynamic IP address. You must be on the same network as the AutoHybrid IP2.

- Windows PCs running Vista or later: Open Windows Explorer and navigate to Network. Users can connect by simply clicking on the icon representing the AutoHybrid IP2.
- Windows / Mac / Linux: Log into the router connected to the Autohybrid to view the the IP address of connected devices.
 1. Enter the Router's IP address into the address bar of your internet browser to access the router's control

panel. The IP address can be found on the base of the router or in the router's manual.

2. Enter a username/password when prompted. If they have not been changed from the default, the router login credentials can be found in the router's documentation.
 3. The AutoHybrid IP2 will be displayed in the router's connected devices list with a hostname of AutoHybrid-IP2.
- Use an IP address scanning application.

Tip: For easy identification, disconnect unused devices from the network and connect only one AutoHybrid at a time. The MAC address can be found on the bottom of your AutoHybrid IP2 but we recommend labeling the device with the IP address or the Account Name registered to the device.

Logging In

Enter the AutoHybrid IP2's IP address in the address bar in your browser to access the AH IP2 GUI.

- Default Username: admin
- Default Password: admin

See Page 9 to change username and password.

- Username:
- Password:

Graphic User Interface

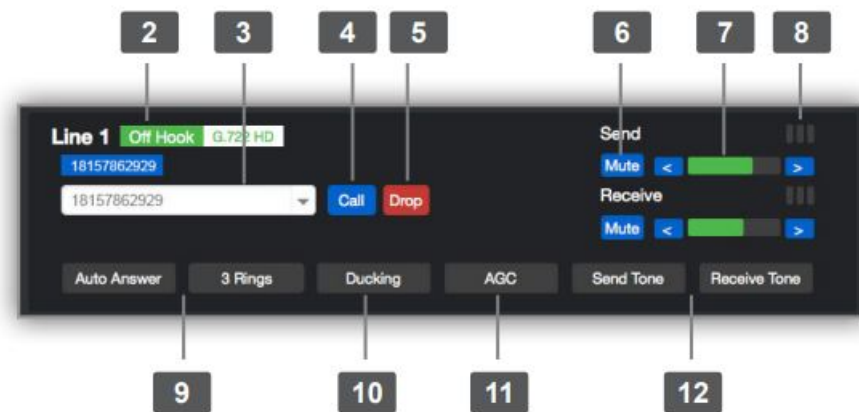
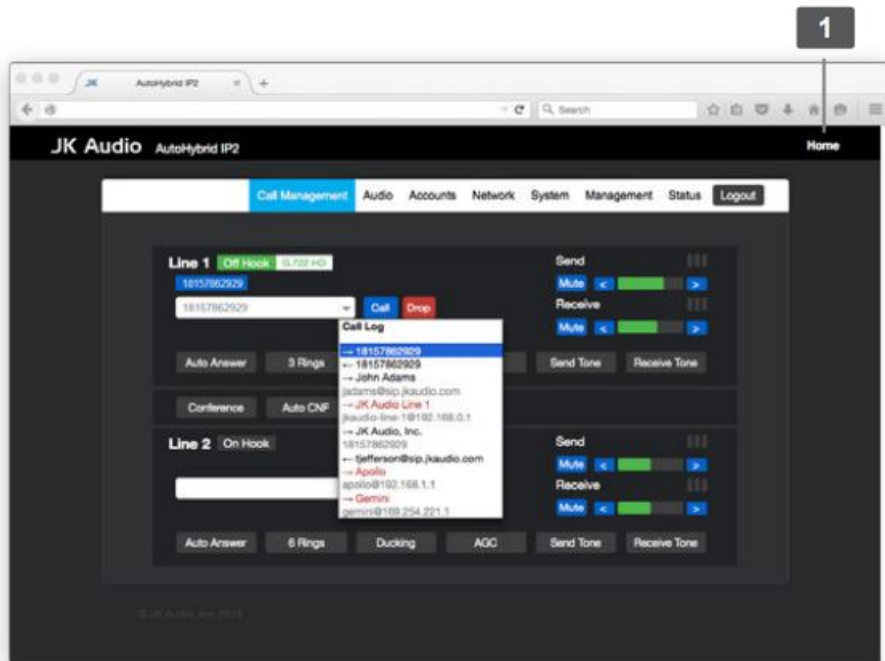

Note: Controls & Indicators 2-12 only apply to the corresponding line.



Call Management

Device Friendly Name

Edit the Friendly Name under the System tab.

Line Status, Caller ID, Active Codec, Caller Name

Indicates when a line is On Hook, Off Hook or ringing. Caller ID and the active Codec will appear adjacent to the Line Status. If it is available, the Caller Name will appear below the Line Status.

Phone Number Input

- A. Enter a phone number or a valid SIP address. (Username@Domain) For outbound calls in the US, dial 1, then the area code. (18005551234)

- B. Click on a Username/Number from the Call Log to dial a recent caller.

Call Button

Press <Call> to answer an incoming call

Drop Button

Press <Drop> to hang up a call.

Mute Button

Mute Buttons for Send and Receive Audio.

Volume Controls

Adjust the volume for Send and Receive Audio.

VU Meter

Individual peak indicators for Send and Receive Audio.

Auto Answer & Ring Count

Disable/Enable Auto Answer. Select the number of rings before Auto-Answer takes the line off-hook.

Ducking

Lowers the caller's audio level by 9 dB when local audio is present.

AGC

Automatically adjust the gain of caller audio so all callers are received at an average level.

Test Tones

Send a full scale 0 dB, maximum output level 1kHz tone down the line.

Conference

Conference lines 1 & 2 together when both lines are off-hook and indicates a conference is active. Edit Conference mode options In the Audio menu (Audio> Conference Modes).

Auto CNF

Automatically conference lines 1 & 2 together, when both lines are off-hook.

Accounts

General

Registering

AutoHybrid IP2 replaces your VoIP phone, therefore you must register it with your VoIP service. On the Accounts tab, enter your account information. After you enter ALL of your account information, click <Save> and <Restart SIP Service> for changes to take effect. Your Account information is saved on the AutoHybrid IP2, it will not need to be re-entered unless it is unregistered.

Account Name (ex: Studio1)

This is only used to identify your IP2 in your configuration and system logs. It is not necessarily required for registering your IP2 with your SIP service/VoIP phone system. Create a friendly name that is easy to read and remember. An example would be a host's name to identify the device as opposed to its IP address.

Display Name (ex: John)

When making peer-to-peer calls, this is how you will be identified to the party you are calling. When using a SIP

service and making a call by dialing a phone number, the number assigned to your account by your SIP service/VoIP phone system may be used to identify you to the party you are calling. Caller ID must be supported/provided by your SIP service/VoIP phone system in order for the party you are calling to see your identifying information. The Display Name may be the same as your Username but should be more accountable if you have a popular username.

Username / Number (ex: J12345)

This information will be provided by your SIP service/VoIP phone system. Enter the username that is associated with your SIP account. If this field is left blank, or if you enter the information incorrectly, you may have difficulty registering/using the IP2 with your SIP service/VoIP phone system.

Domain (ex: sip.ringcentral.com)

Enter the domain of your registered SIP account. If registering IP2 with a SIP service, enter the SIP Domain provided by your SIP service. If you are installing the IP2 on your network, and you will not be accessing outside lines, leave this field blank. Leaving the Domain field blank will only allow calls to devices within the user's network.

Domain Registration

Check this box if you are registered with a domain to be able to receive calls. If unchecked, the account will be started in Peer-to-Peer mode and you will not be able to call outside of your local area network.

Password

Enter the password provided by your SIP service/VoIP phone system IT administrator.

Topology**SIP Transport Mode**

There are three SIP Transport Modes: Automatic, TCP, and UDP. Automatic should be selected unless otherwise specified by your SIP service/VoIP phone system IT administrator.

Local Port

This port number will be provided by your SIP service/VoIP phone system IT administrator. If the wrong port number is entered, you may encounter problems registering or using the IP2 to make or receive calls..

STUN (Session Traversal Utilities for NAT)

STUN usage recommendation and, if necessary, the STUN server name and port assignment (located under Network>Additional Settings) will be provided by your SIP service provider/VoIP phone system IT administrator.

Line Assignment:

The IP2 allows the user to set up two different accounts, Account 1 and Account 2. This box gives the user the option to assign account configuration to either Line 1, Line 2, or Both lines.

QoS (Quality of Service)

The Account Quality of Service (QoS) tab, contains two attributes which define the Differentiated Services (DiffServ) Code Point (DSCP) element of the DS field of IP packets for RTP and SIP traffic. The default DSCP settings are fairly standard and should only be modified as specified by a network administrator with knowledge of a specific network's QoS implementation.

Advanced**Auth Username**

Enter the Authorization ID provided by your SIP service/VoIP phone system IT administrator.

Proxy and Proxy Port

A proxy, or proxy server, is basically another computer which serves as a hub through which internet requests are processed. Enter the proxy address and port number provided by your SIP service/VoIP phone system IT administrator here. Without this information, the IP2 will not know where to send a request to contact another device.

Registration Lifetime

This is the time period (in seconds) for which an account Registration is valid. After expiration of this period, the registration at the service provider for this account is no longer valid. Re-registration is done automatically. A registration for this account will be sent to the service provider sometime before the last registration is due to expire. Your SIP service provider/VoIP phone system administrator will provide you with instructions on what information, if any, needs to be entered/changed here.

Keep-Alive

Enables sending periodic keep-alive data to the SIP server to ensure that the communication channel remains open. When the AutoHybrid IP2 is behind a router running network address translation (NAT), this prevents the NAT from closing the channel prematurely. Your network system administrator will determine if this box needs to be checked.

Silence Suppression

This is a method for reducing the average bandwidth used by the audio. It is useful in instances where long durations of silence are expected/encountered. Your SIP service provider/VoIP phone system IT administrator will determine if this box needs to be checked.

Account Status

An account is ready to make or receive calls if the Account Status is Peer to Peer Registered or Proxy Registered. If the Account Status is Proxy Registering, Configured, Configuring, Not Configured or Unknown, the account is not ready and may have a configuration error.

Account Error

If a registration error is detected or reported by the service provider, an Account Error will be displayed. If the Account Error is Proxy Error or Proxy Timeout, there may be an error in the Username, Domain, Proxy or Proxy Port configuration. If the Account Error is Authentication Failure or Register Failure, there may be an error in the Username, Auth Username or Password configuration. If the Account Error is Proxy Error, there may be an error in the Proxy or Proxy Port configuration.

Codec Preferences

Waveform based codecs quantize the actual waveform. Speech based codecs use a model of speech production for better compression. Waveform based codecs generally work better. Select the desired codec/s from the list of codecs available and click <Enable> to move it to the preferred list. When there is more than 1 preferred codec, the <Move Up> and <Move Down> buttons set priority for which codec is used. The preferred codecs list is saved on the AutoHybrid IP2, therefore users will not have to reselect their preferred codecs for each use. Users can save and store multiple profiles on their computer for different applications that might require different codecs. Users will be able to backup/download profiles and restore/upload their configurations from the Management tab.

Conference Modes

These options allow you to enable and disable Send and Receive mix features. Keep in mind that no matter what options are selected, both callers will always be able to communicate with each other in Conference mode.

Send Mixes

- A. Send – Not Mixed
 - <Line In 1> audio to Caller 1.
 - <Line In 2> audio to Caller 2.
- B. Send – Mixed
- <Line In 1> and <Line In 2> audio is mixed and sent to both Callers.

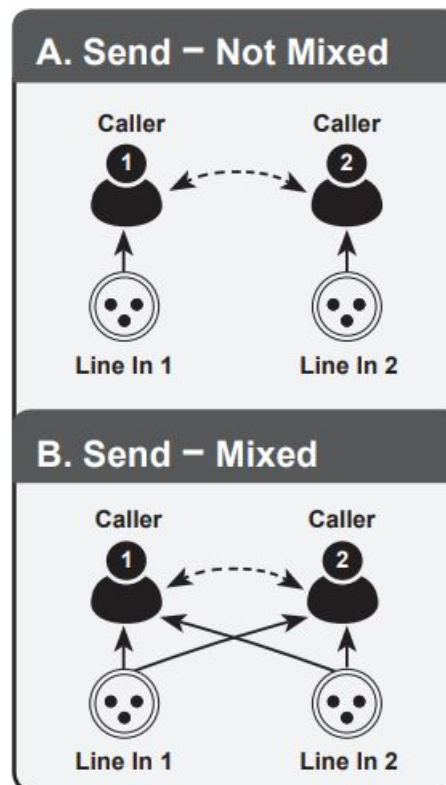

Receive Mixes

- A. Receive – Not Mixed
 - Caller 1's voice/audio will only be on the <Line Out 1> output XLR.
 - Caller 2's voice/audio will only be on the <Line Out 2> output XLR.
- B. Receive – Mixed
 - Callers 1 and 2 voices will be mixed on both <Line Out> XLR outputs.
- C. Receive – Mix Minus
 - A full mix of all audio on each of the caller XLR outputs, minus the <Line In> audio for that phone line.
 - <Line Out 1> XLR contains:
 - Caller 1 + Caller 2 + <Line In 1>.
 - <Line Out 2> XLR contains:
 - Caller 1 + Caller 2 + <Line In 2>.

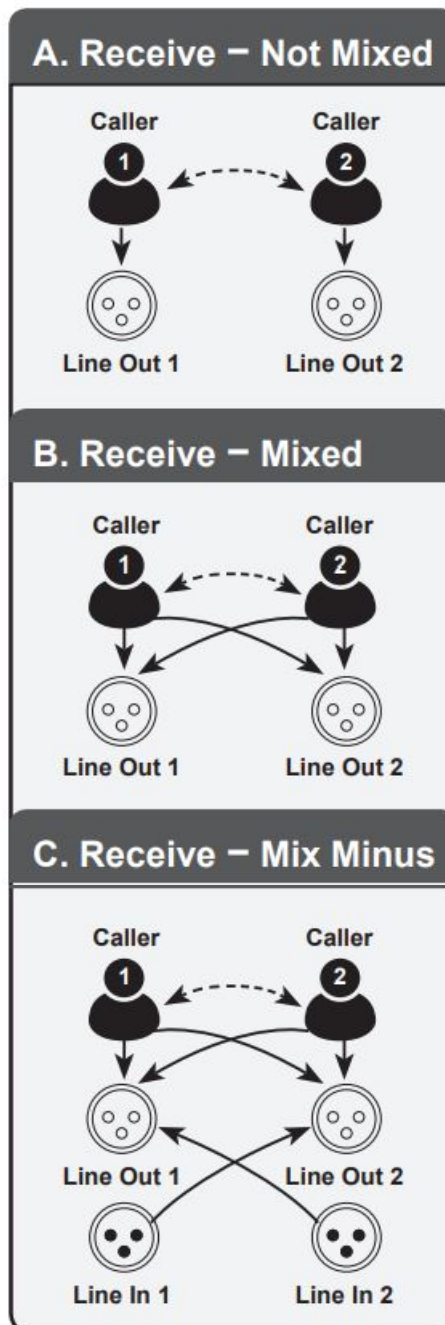

Network / System

WAN Settings

Dynamic IP

AutoHybrid IP2 is assigned an IP address in the network.

Static IP

Obtain a static IP address from your internet service provider to have remote access via the public internet or create a unique static IP address on your LAN.

PPPoE

Point to Point Protocol over Ethernet is used by some internet service providers to provide an authentication mechanism for connecting to the internet. Most of the parameters entered here should have been provided by your ISP. Service Name can generally be left blank. Mode is the method of maintaining a connection. On Demand mode will drop the connection to the internet after there is no activity for Idle Time. It will reconnect when an outbound connection is requested. The default Idle Time is 3 minutes. Keep Alive mode will send keep alive messages every Redial Period to maintain the connection. The default Keep Alive period is 1 minute.

VLAN Settings

Enable

The Enable checkbox enables the Virtual LAN (VLAN) tagging. If the network does not support VLAN and the VLAN tagging is enabled on the IP2, the IP2 will become unreachable on the network. Resetting the network configuration from the front panel will disable the VLAN tagging and reset the VLAN configuration to default settings.

VLAN ID

VLAN ID is the VLAN identifier which indicates which VLAN the device is in.

VLAN Priority

VLAN Priority specifies the Priority Code Point (PCP) field in VLAN header. The priorities are as defined in the 802.1p Class of Service (CoS) standard..

Identification

Friendly Name

Change the Friendly Name used to identify your AutoHybrid IP2.

User Name

Change the login username and password.

Management

Configure

Product Registration / Firmware Updates

Your AutoHybrid IP2 contains many advanced features, but we are constantly looking for ways to improve. Product Registration allows us to keep you informed of any firmware updates that become available in the future. Please register by visiting: <http://www.jkaudio.com/support/>

New Firmware

To update the firmware, you must request a .bin update file from support@jkaudio.com. Please provide the IP2 serial number with your request. In the AutoHybrid GUI, click <Browse> on the Update tab, then find the .bin file you just downloaded then click <Update Firmware>. AutoHybrid will restart and prompt you to log in again after it is done installing.

Configure/Upload

Configure the IP2 with a saved configuration by clicking <Select configuration file>. Once you have selected a valid configuration file, upload it by clicking <Upload Configuration>.

Backup/Download

Save all changes you made including account information and Codec selection by clicking <Download Configuration>.

Reboot/Restore

Reboot

To Reboot the IP2, press <Reboot>.

Restore

To restore the factory configuration of the IP2, press <Restore Factory Settings>.

FAQs

1. I am receiving error message: NOT ACCEPTED HERE When both end-points do not share a preferred codec, the call might fail. If there's a compatibility issue between the two end-points, error message: Not Accepted Here will be displayed. This means that the two end-points could not agree on a codec. To resolve this issue, make sure the two end-points have a few codecs in common.
2. **I changed my network settings and now I can not connect to the AutoHybrid IP2.**
Perform a Network Reset found on page 15 to reset your device to the default Dynamic IP setting. See page 5 to find the Dynamic IP address.
3. **I have lost my power supply for my AutoHybrid IP2.**
I have a power supply that fits from a different product. Can I use this instead?
No! Never use a power supply other than the one that was supplied by your manufacturer. Power supplies are available in either AC or DC output with many combinations of voltage and available current. Most consumer power supplies are not regulated. This could invariably damage your equipment, and also create a great deal of noise. Our products are designed for and tested with their respective power supplies for optimum operation. If you have lost your power supply, please contact your JK Audio dealer or our Customer Service department. AutoHybrid can also run using PoE power, supplied over the ethernet cable from a PoE equipped switch or router.
4. **Will the USB port on the AutoHybrid IP2 act as a sound card when connected to a computer?**
No. The USB port is not designed to exchange audio between the AutoHybrid IP2 and your computer.

Troubleshooting

Error Indicators

Please note that some issues may be resolved by refreshing or updating your browser.

- Conference LED flashes rapidly:
 - **X** No ethernet link detected.
- Conference LED flashes 250ms on, 250ms off:
 - **X** No IP address detected.
- LAN Jack LEDs are orange/red, or unlit:
 - **X** The LAN jack is not receiving a signal from the network or the ethernet cable is not connected properly.

Basic Reset

Insert a paperclip to restart AutoHybrid IP2 instead of power cycling



Confirmation of the reset is indicated by lighting all the LEDs.

Network Reset

To reset the AutoHybrid IP2 to its default DHCP settings: Hold the <Line 1 Call> & <Line 2 Drop> for 10 seconds.



Confirmation of the reset is indicated by lighting all the LEDs.

Factory Reset

To clear your AutoHybrid of all saved information and restore it to its factory settings: Hold the <Line 1 Call> & <Conference> for 10 seconds.



Confirmation of this reset is also indicated by lighting all the LEDs.

Block Diagram

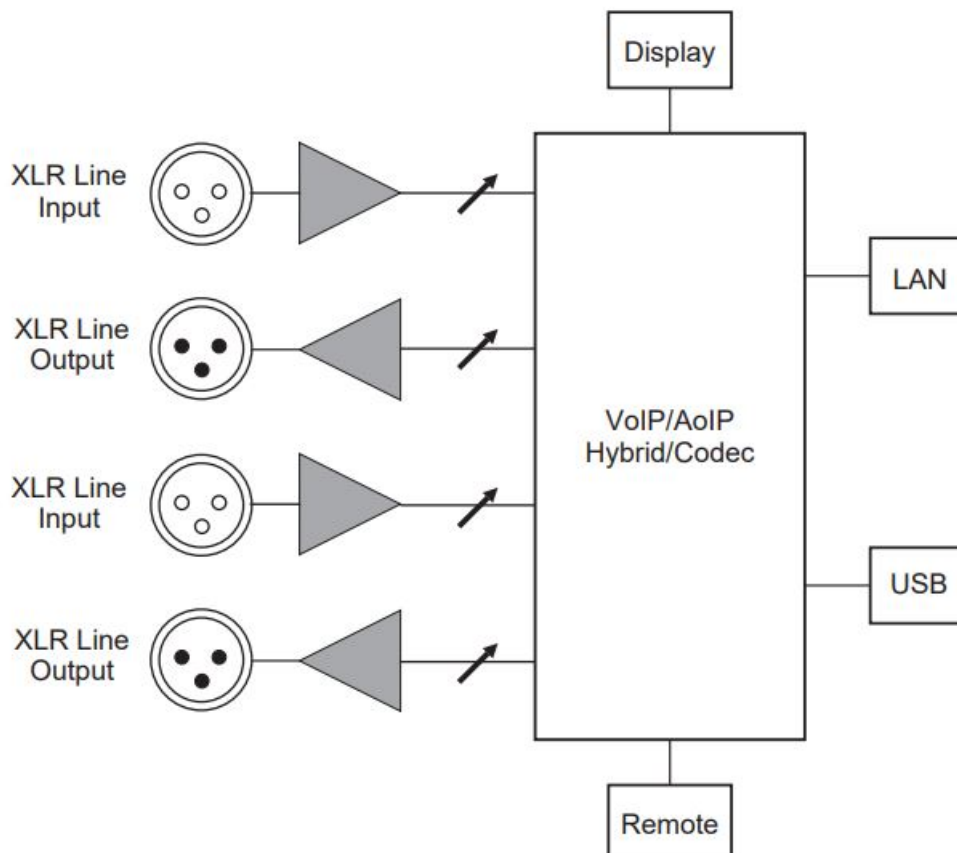

Technical Information

| Input | Impedance / Level |
|---------------------------------------|---|
| Balanced Female XLR: | 20k ohms / 500 mV RMS; -4 dBu nom.; +10 dBu max |
| Output | |
| Balanced Male XLR: | 50 ohms / 500 mV RMS; -4 dBu nom.; +12 dBu max |
| Operation | |
| Maximum Ambient Operating Temperature | 50 deg C (122 deg F) |
| Maximum Operating Altitude | 2,000 meters (6,562 feet) |
| Misc | |
| Remote Jack: | RJ50 Proprietary interface to JK Audio Products Only |
| Power: | PoE (Power over Ethernet) or +9 VDC with AC power supply |
| Size: | 7.6" x 5.3" x 1.5" (20 x 14 x 4 cm) |
| Weight: | 1.2 lbs (0.5 kg) |
| Remote Header Pinout | |
| 1: Line 1 Call (NO) | Pull this pin to ground momentarily to simulate pressing the <Call> button. |
| 2: Line 1 Drop (NO) | Pull this pin to ground momentarily to simulate pressing the <Drop> button. |
| 3: Line 1 OH/Ring LED | Supplies +3.3 VDC, 40 mA to external LED. |
| 4: Chassis Ground | |
| 5: Line 2 Call (NO) | Pull this pin to ground momentarily to simulate pressing the <Call> button. |
| 6: Line 2 Drop | Pull this pin to ground momentarily to simulate pressing the <Drop> button. |
| 7: Line 2 OH/Ring LED | Supplies +3.3 VDC, 40 mA to external LED. |
| 8: Chassis Ground | |

FCC Compliance Notice

FCC Part 15 Subpart A Compliance

This equipment has been tested and found to comply with the limits for a Class A digital device, pursuant to Part 15 of the FCC Rules. These limits are designed to provide reasonable protection against harmful interference when the equipment is operated in a commercial environment. This equipment generates, uses, and can radiate radio frequency energy and, if not installed and used in accordance with the instruction manual, may cause harmful interference to radio communications. Operation of this equipment in a residential area is likely to cause harmful interference in which case the user will be required to correct the interference at his/her own expense. Changes or modifications not expressly approved by JK Audio can void the user's authority to operate the equipment.

| | |
|---|---|
| Manufacturer's Name: | JK Audio, Inc. |
| Manufacturer's Address: | 1311 E 6 th Street Sandwich, Illinois 60548 USA |
| Declares that the product: | |
| Product Name: | AutoHybrid IP2 VoIP / AoIP Codec |
| Model Numbers: | AutoHybrid IP2, AutoHybrid IP2-AE |
| Conforms to the following Product Specifications: | |
| Safety: | IEC 60950-1:2005 (Second Edition) +Am 1:2009 + Am 2:2013 |
| ESD: | EN 55024:2010 EN 61000-3-2 EN 61000-3-3 |
| Emissions: | EN 55022:2010 FCC Part 15, Subpart B ICES-003, Issue 5 AS/NZS CISPR 22:2009 |
| The product herewith complies with the requirements of the following Directives and carries the CE marking accordingly: | |
| | LVD 2006/95/EC (Safety) EMC 89/336/EEC (EMC) RoHS Directive 2015/863 |
| The Technical File containing supporting documentation is maintained at: | |
| | JK Audio, Inc (Corporate Headquarters) Compliance Manager 1311 E 6th Street Sandwich, Illinois 60548 USA 815-786-2929 phone 815-786-8502 fax |

Declaration of Conformity

Declaration of Conformity

User Guide Version 4/26/22 JK Audio, Inc. 1311 E 6th St. Sandwich, IL 60548 United States Telephone: 815.786.2929 Toll-Free: 1.800.jk audio Fax: 815.786.8502 www.jkaudio.com © 2022 JK Audio, Inc. All rights reserved.

Documents / Resources

| | |
|---|---|
|  | <p>JK Audio AutoHybrid IP2 VoIP/AoIP Codec [pdf] User Guide AutoHybrid IP2 VoIP AoIP Codec, AutoHybrid IP2, VoIP AoIP Codec</p> |
|---|---|

References

- [JK JK Audio](#)

Manuals+