



Intellitronix DP7006W LED Direct Replacement Digital Bargraph Dash Kit Installation Guide

[Home](#) » [Intellitronix](#) » Intellitronix DP7006W LED Direct Replacement Digital Bargraph Dash Kit Installation Guide 



Ford Fox Body Mustang
Part Number: DP7006
Year Series: 1979-1986



Made in America
Lifetime Guarantee

Thank you for purchasing this instrument from Intellitronix. We value our customers!

* Always disconnect the battery before attempting any electrical work on your vehicle. *

Contents

1 KIT COMPONENTS

2 WIRING

INSTRUCTIONS

3 SPEEDOMETER

4 CALIBRATION

5 Documents / Resources

5.1 References

6 Related Posts

KIT COMPONENTS

One (1) Digital Circuit Board (with Speedometer, Tachometer, Fuel, Voltmeter, Water Temp, Oil Pressure Gauges)

One (1) Smoked Acrylic Lens * Peel off protective covering from both sides *

One (1) Cutout Black Film Overlay

One (1) Temperature Sending Unit (S8013) – 1/8" NPT, 0-255 Deg., 1/2" NPT Bushing

One (1) Pressure Sending Unit (S8868) – 1/8" NPT, 0-100 PSI Oil Pressure

One (1) Ford Speedometer Sensor (S9024)

One (1) Mounting Kit to Include:

- Six (6) #6 x 1" Nylon Spacers
- Five (5) #6 x 2" Flat Head Machine Screw
- One (1) #6 x 1 1/2" Pan Head Screw
- One (1) #6 x 1" Flat Head Machine Screw
- Six (6) #6 x 5/16" Nylon Spacers
- One (1) #6 Nylock Nut

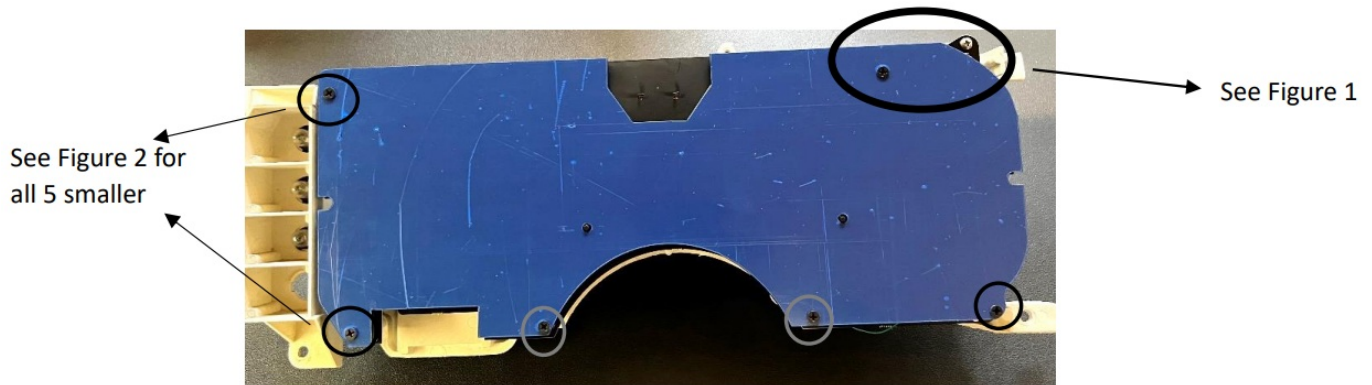

Please note to remove the protective film from BOTH sides of the smoked acrylic before installing. Also, the assembly will go: smoked acrylic → overlay → 5/16" Spacer → circuit board

Figure 1



Figure 2

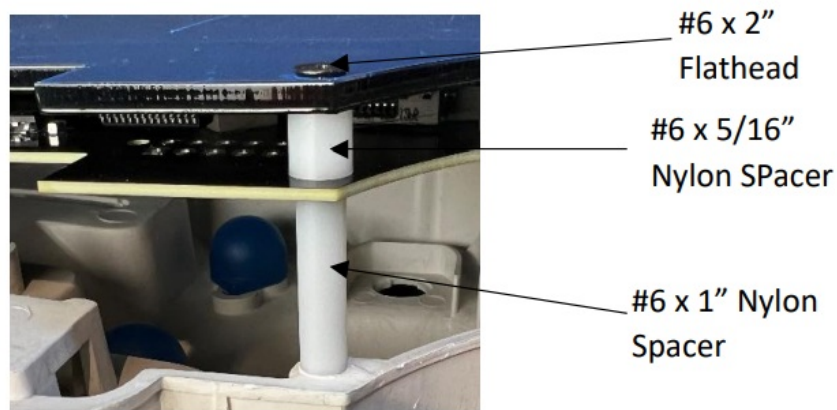

WIRING INSTRUCTIONS

Note: Automotive circuit connectors are the preferred method of connecting wires. However, you may solder if you prefer.

Note: LS Engines or any other Computer based engine systems must use provided sensors along with the factory senders to feed the computer

Ground – Black–This is the main ground for the display system. A wire should be run from this board to the vehicle engine block for the best ground. Use 18 AWG or larger wire to ensure sufficient grounding. Proper vehicle grounding is extremely important for any gauges (or electronics) to operate correctly. The engine block should have heavy ground cables to the battery, frame, and firewall. Failure to properly ground the engine block, senders, or digital dash can cause incorrect or erratic operation.

Battery Red–Connect the +12 Volt terminal to constant +12V power from the battery power source. Using a 5-amp fuse or an inline 5-amp fuse holder Use 18 AWG wire ensure the system receives a sufficient power feed.

Power – Pink–Connect the power terminal to accessory +12V power from the fuse panel or vehicle wiring harness. Using a 5-amp fuse or an inline 5-amp fuse holder. This terminal should have power when the key is on or in accessory position. Use 18 AWG wire to ensure the system receives sufficient power feed.

red with white strip will be used in speedometer section

Water – Blue – This is the signal wire for water temp. This gauge is incompatible with other sending units, so you must replace the existing water temperature sending unit with the included sender.

Water –Black/Blue -This is ground for water temp sender if using a 2 wire sending unit, if you were provided with a 1 wire sender, this can be wired to engine block ground

Oil Pressure – Orange (Signal wire) Replace the existing oil pressure sending unit with the unit included. Connect to the signal post on the oil sender.

Oil Pressure – Orange/Black or Orange/Brown (Ground wire) Connect to the ground post on the oil sender.

Securely connect orange wire to S terminal

Securely connect black/orange wire to G terminal

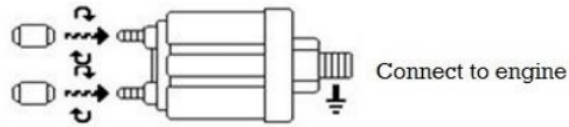

Dimmer – Purple Connect to the parking lights to dim the LEDs 50% when the headlights are on. However, *DO NOT * connect to the headlight rheostat control wire, or the dimming feature will not work properly and may cause damage to Unit. You can also connect to an auxiliary switch for dimming control.

High-Beam – Brown – Connect the brown wire on the Dash unit to your high beam headlight circuit. This wire is powered on when the high beam is turned on.

Right Turn Signals – Grey with White strip RIGHT turn signal. This wire works when 12v is activated.

Left Turn Signals – Grey with Black strip Left turn signal. This wire works when 12v is activated.

Fuel – Yellow – The fuel gauge sending unit is not normally supplied because the display system can use the existing fuel level sending unit in the tank in most cases. If your wiring harness already has a single wire routed through the vehicle for the fuel sender, then it may be used. If using a wire from an external harness, make sure that the wire does not have power. Fuel senders reference their ground from the sender mounting plate. Connect the yellow wire to the factory sending unit.

Fuel –Black/Yellow – Run a new ground wire and attach to your Fuel sending unit housing to ensure proper fuel gauge operation. If the sending unit does not have sufficient ground it will not work properly.

Both switches in the up position for Ford/Chrysler

FORD FUEL DIP SWITCH



DIP SWITCH – ONE ON – — — – DIP SWITCH TWO ON =73 TO 10

DIP SWITCH – ONE ON – — — – DIP SWITCH TWO OFF = 16 TO 158

DIP SWITCH – ONE OFF – — — – DIP SWITCH TWO OFF = 240 TO 33

DIP SWITCH – ONE OFF – — — – DIP SWITCH TWO ON = 22 TO 145

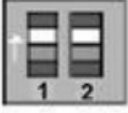
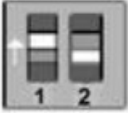
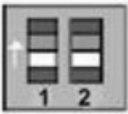
Fuel Selector Switch Position

Manufacturer	Switch Position	Ohm Range (Empty to Full)
FORD		73-10 OHM
FORD		16-158 OHM
FORD		240-33 OHM
FORD		22-145 OHM

Note: FUEL GAUGE TEST The most common problem with our Fuel Gauge not working is the circuit is not complete. The easiest way to test this is to use a voltmeter and test for continuity on wires going to fuel sender. With wire disconnected from Fuel Gauge check for continuity to ground. Without this the Gauge will not work.

Voltage Gauge – This Gauge Requires no wire hookup. Volt Gauge is built into the dash panel and is powered by the main power and ground connection of the dash. It does have an Adjuster to fine tune the voltage. Note: you will need to adjust it before fully installing the dash

Trip/Cal Button – Next to Speedometer – This for access to reset your trip odometer or other speedometer functions.



Tach program Button – Next to Tachometer This is used to set the other functions of the tachometer.

SPEEDOMETER

Speedometer – White – (Factory sender with Powertrain Control Module) When using a LS engine swap, you will need to pick up the Speedometer signal wire from the PCM Pin 50 on the red connector.

(This pin may Differ. Refer to your vehicles Pinout Chart for accuracy). Any other Computer based engine will need to use the PCM/ECM to run the speed signal for the Speedometer. (Consults Pinout) Speedometer – White – (Factory two wire sender no PCM) – Most vehicles built after 1984 have an electronic transmission sender. If your vehicle is already equipped with an electronic transmission, then the electronic vehicle sender will usually have Two wires attached to it. One connects to the Signal wire on dash (we prefer this to be high output). The other wire (Low output) Ground at the Engine block. To find High and Low output wire color or pin location will need to be looked up by Vehicle vin or Model and year.

Speedometer – White (Intellitronix Speed Sender) – Disconnect the mechanical speedometer cable from the transmission and thread the new electronic sensor onto the transmission. This panel comes with a 3wire sensor. If you are using this sensor you must follow these wiring instructions.

White -Wire is the speed signal; connect this to the speed signal wire on your gauge.

Red – Wires switch power (12VDC) and must be wired to Red/White on your Gauge.

Black – Wire is speed sensor ground and must be wired to Black/White on the Gauge.

NOTE:(Twist all Three wires together and this will provide an additional level of interference protection.) The speed signal wire should not be routed alongside the tachometer, ignition, or any other high-current or high-voltage wires

Note: If doing a LS engine swap, pick up the tach signal wire from the ECM/ECU and then set the tach switch to 4-cylinders. You may also need to order the Intellitronix LS Engine Swap Adapter Kit for Series 1, 2 and 3 engines. The part number is 8014LS. If you are getting the tach signal from the ECU, the resistor in the adapter kit will help pull a stronger signal for the tachometer. If your engine is a LS the Tachometer will need to be put into 4 cylinder mode

Tachometer – Green wire – Connect the wire from the tachometer to the negative terminal of the coil or a direct tach output lead from your distributor or electronic control module. If you are using an aftermarket capacitive discharge ignition system, such as an MSD, you must use the designated ‘tach output’ connection on the electronic box. Do not make any connections directly to the coil with this type of system. With high output Ignition systems may also create frequency noise that may interfere with operation of gauges that may require a tachometer filter.

If your vehicle has a HEI ignition, connect to the terminal marked ‘TACH’, or, on some systems, a single white wire with a spade terminal.

If your vehicle has a magneto system, connect the tach signal wire to the negative side of the coil. Do not connect the tach terminal to the positive (+ or high voltage) side of the ignition coil or may need a Tachometer adapter for proper operation of your Digital Gauges.

Diesel engines will require a Diesel Tachometer adapter for proper operation of your Digital Gauges.

PROGRAMBLE TACHOMETER SETTINGS

To change settings:

The display will stay in Settings Mode until it receives a signal from the ignition system. To program the unit after starting the engine, shut the engine off and turn on only to the accessory position.

When in accessory mode, the settings menu will scroll through the settings menu. A light tap on the button engages the menu system.

1. Sets # of digits in RPM display, using button, display shows: (hundreds) 8800, (tens) 8880, and (ones) 8888.
2. Sets # of cylinders using button, display shows: 1cy, 2cy, etc.
3. Sets first digit on max RPM on gauge bar display (in thousands) using button, display shows: 1000 to 9990.

CALIBRATION

The speedometer leaves the factory with a pre-set industry standard setting of 8,000 pulses per mile.

Chances are that you may not need to recalibrate your speedometer unless you have changed the original tire size or the rear end gear ratio.

Note: Do not attempt to calibrate your speedometer until after it is working properly, and you have determined that the speed is incorrect. The calibration procedure will NOT correct a faulty installation or improper wiring. If you attempt to recalibrate your speedometer without making sure the speedometer is receiving pulses from the sending unit, the speedometer will display ‘Err’ and default back to the factory settings.

To calibrate:

1. Locate a measured mile where you can safely start and stop your vehicle. By running the vehicle over this measured distance, the speedometer will learn the number of pulses outputted by the speedometer sensor during a specific measured distance. It will then use this acquired data to calibrate itself for accurate reading. There is a small recall push-button in the center of the panel used to calibrate and read all of the data stored in the speedometer. After installing your speedometer according to the wiring instructions, when the ignition is on it should immediately display the default screen of 0 MPH, if the vehicle is not moving.
NOTE: You will then need to drive your vehicle to the predetermined measured mile. During this trip, the speedometer should read something other than 0 MPH. If it does not change, return, and locate the problem before continuing. Otherwise, proceed with the calibration.
2. Stop at the beginning of the measured mile with your vehicle running and in odometer mode (NOT trip mode), press and hold the push-button until the odometer displays 'HI-SP'. On its own, the gauge will then cycle through the recorded performance in the following order: '0 – 60', '1/4', 'ODO', and 'CAL'.
3. While 'CAL' is displayed, quickly tap the push-button once. This will put the speedometer in Program Mode. If you did not tap while 'CAL' is displayed, the pulses per mile will be displayed on the odometer and the display will go back to MPH mode. Otherwise, you will now see 'CAL' displayed along with the number '0'. This indicates that the microprocessor is now ready for calibration.
4. When you are ready, begin driving on the metered mile. You will notice that the reading will start counting up. The odometer will begin to display the incoming pulse count. Drive the vehicle through the measured mile (speed is not important, only the distance traveled).
5. At the end of the mile, stop and press the push-button again. The odometer will now display the new number of speedometer pulses that were registered over the distance. The odometer will continue to display the pulse reading for a few seconds. Once it reverts to the default mode, you have successfully calibrated your speedometer.

Warning: If, while in 'CAL' mode, you do not move the vehicle and press the button again, the microprocessor will NOT have received any data. The unit will display 'Err' and will revert to the factory settings. At a minimum, drive some distance and return to the start if necessary. If you miss stopping the display at 'CAL', simply repeat the steps.

Trip Distance

A single tap of the recall button will activate the trip meter in the odometer display. A decimal point will appear which will indicate that you are in trip meter mode. Holding the recall button will clear out the trip distance. To return to the default odometer display, tap the recall button again. The decimal point will disappear, indicating that you are back in the default odometer display.

Setting the Odometer

While scrolling through 'CAL' mode you will see 'ODO' appear. This will allow you to enter the vehicle's actual mileage. Press the trip button again at this point and you will enter the odometer set up mode. Press quickly to change the number of the digit on the right. Press and hold to advance to the next digit. Do this for all 5 digits. For Example: To enter the mileage reading 23456 into the odometer, at the 'ODO' prompt, tap the small black button (quickly) two times, until the number 2 is displayed. Then press and hold the button until the numbers 20 are displayed. Tap the button 3 times until 23 is displayed. Press and hold the button until 230 is displayed and continue in this manner until 23456 is displayed. The speedometer will advance to the home screen, five seconds after the last number is entered.

Recording and Viewing Performance Data

Follow these steps to record and recall Performance Data (high speed, 1/4mile ET, and 0-60 time):

1. Before each run, your car must be at a complete stop at the starting position. Press and hold the pushbutton as it cycles through the performance data. At the end, the odometer will reset and all performance data will be cleared. This will not affect your stored calibration value or the odometer reading.
2. Press the push-button until 'HI-SP' is displayed. The gauge will automatically cycle through the performance

data.

3. Start the run, pass, session, etc., as mentioned above.
4. When finished, repeat Step 2 to view the data gathered from the run. While stopped, you can view this data as often as you wish. However, once it finishes scrolling one time, the memory is ready to record new data and will begin recording again once the vehicle starts to move. The highest speed measured over multiple runs will be retained in memory.

DP7006
5/9/2023
www.intellitronix.com

Documents / Resources

	<p>Intellitronix DP7006W LED Direct Replacement Digital Bargraph Dash Kit [pdf] Installation Guide DP7006W LED Direct Replacement Digital Bargraph Dash Kit, DP7006W, LED Direct Replacement Digital Bargraph Dash Kit, Digital Bargraph Dash Kit, Bargraph Dash Kit, Dash Kit</p>
---	--

References

- [Gauges | Intellitronix | Eastlake](#)

[Manuals+](#)