



intelbras IVP 9000 MW Passive Infrared Motion Sensor User Manual

[Home](#) » [intelbras](#) » intelbras IVP 9000 MW Passive Infrared Motion Sensor User Manual 

intelbras

IVP 9000 MW Passive Infrared Motion Sensor User Manual

Contents

- [1 IVP 9000 MW Passive Infrared Motion Sensor](#)
- [2 Care and safety](#)
- [3 Technical specifications](#)
- [4 Características](#)
- [5 Product](#)
- [6 Installation](#)
- [7 Operation](#)
- [8 Test](#)
- [9 Homologation](#)
- [10 Warranty term](#)
- [11 Documents / Resources](#)
 - [11.1 References](#)
- [12 Related Posts](#)

IVP 9000 MW Passive Infrared Motion Sensor

IVP 9000 MW

Passive infrared motion sensor with triple technology

Congratulations, you have just purchased a product with Intelbras quality and safety.

The IVP 9000 MW motion sensor combines microwave detection with passive infrared detection, adopting advanced signal analysis technology to prevent accidental tripping in high-risk intrusion environments.

Developed with 2 Quad PIR sensors and the combination of flat and hemispherical Fresnel lenses, it increases the efficiency of motion detection and reduces undetected areas below the sensor.

To facilitate the installation of the sensor and optimize the installation time, the cabinet contains a snap-in system

using front and rear cover connectors.

Care and safety

- Follow all instructions in the manual for assembling and installing the product.
- LGPD – Data processing by Intelbras: Intelbras does not access, transfer, capture or perform any type of processing of personal data from this product.
- This product is intended for INDOOR and SEMI-OPEN environments.

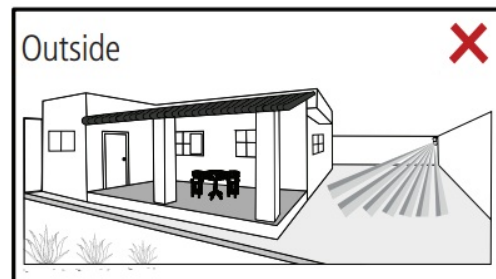
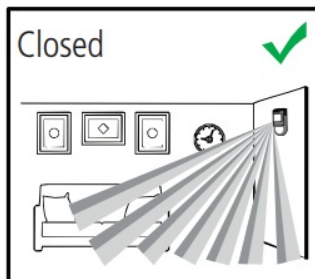
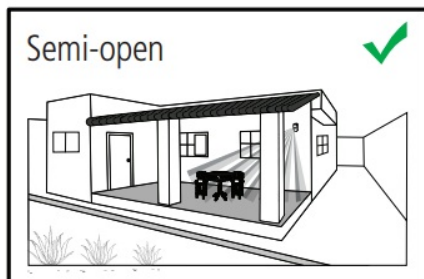

- Do not touch the surface of the infrared (PIR) sensor. If necessary, use a soft, dry cloth for cleaning.
- Do not use the sensor in areas with sudden temperature changes such as air conditioners and heaters, fans, refrigerators and ovens. Do not expose the sensor directly or to reflections from sunlight.

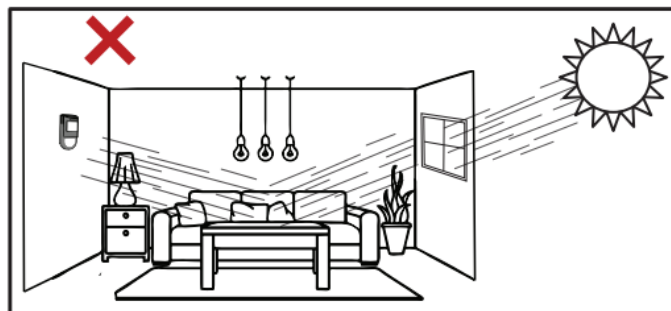
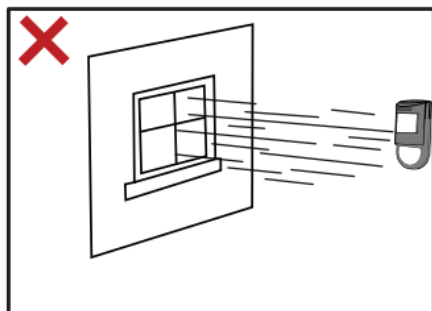
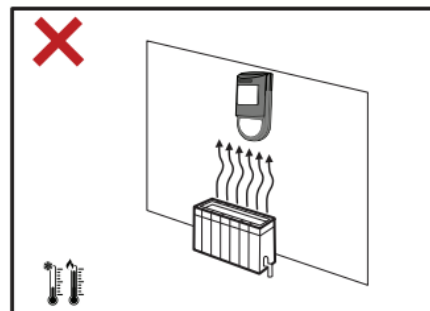
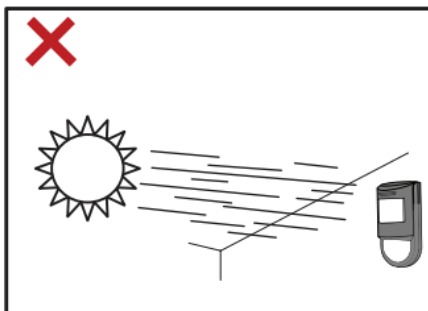
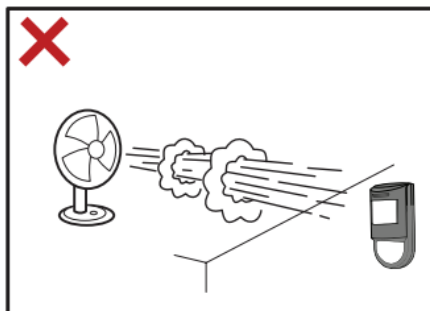

- The PET function is intended for lowland animals weighing up to 10 kg. If the animal is on top of a bench, for example, the PET function can be overridden.

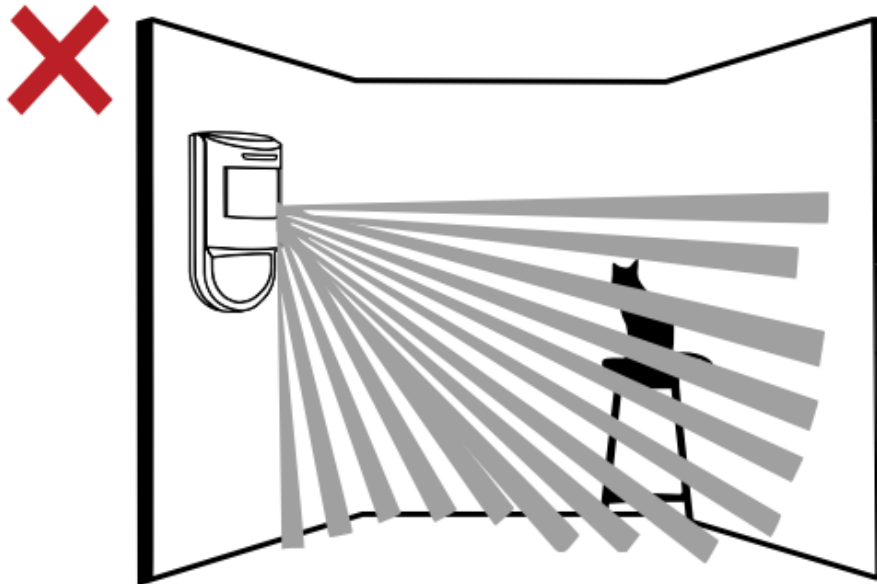

- When installing the sensor in environments with the presence of animals, it is recommended to configure the sensor for a semi-open environment, switch S1 position 3 activated. This way the sensor makes the appropriate sensitivity adjustment and disables the Anti-Camouflage function, if it is enabled.
- Do not place objects in front of the sensor. To secure the detection area, avoid curtains, screens, screens, or any object that blocks the scan.
- The sensor must be installed where an intruder can be easily detected, that is, where it moves transversely to the detection beams.

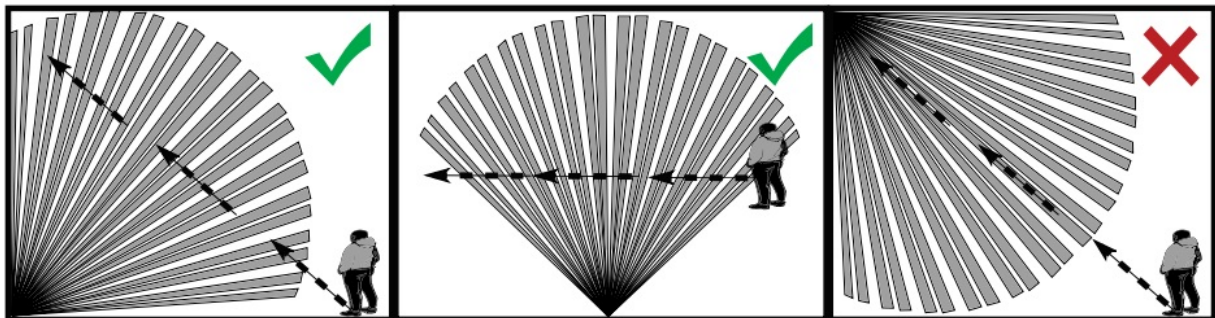

- The sensor must be installed on a flat, fixed, flicker-free surface, with a height between 2.0 and 2.4 meters. It is recommended to install the sensor parallel to the wall for the greatest detection range.

Detection area (Top view)

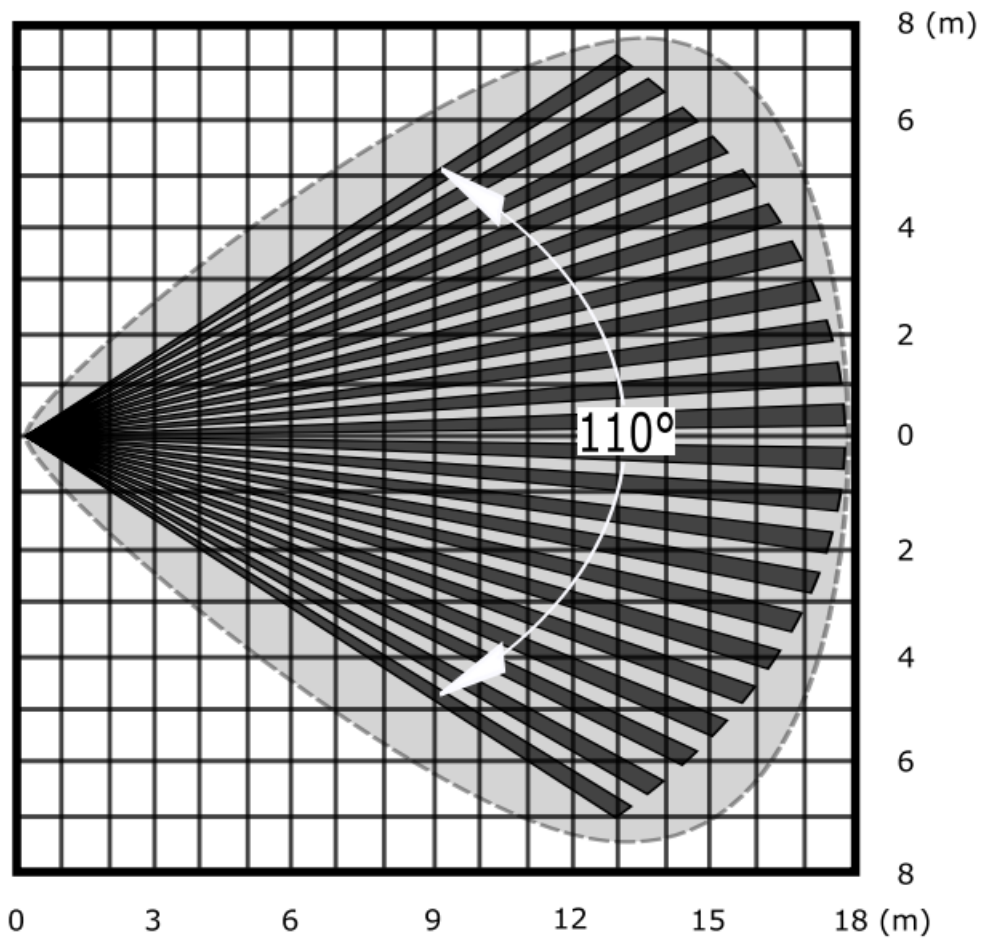

Detection angle (Side view)

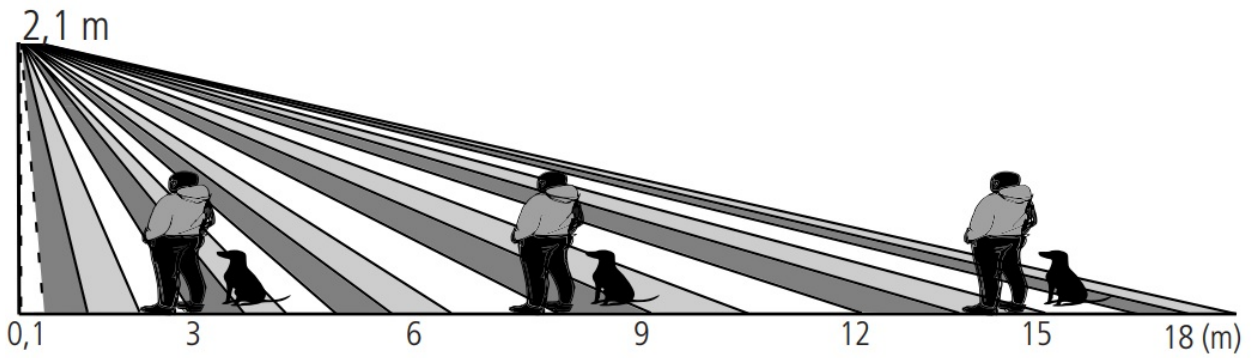

Side view

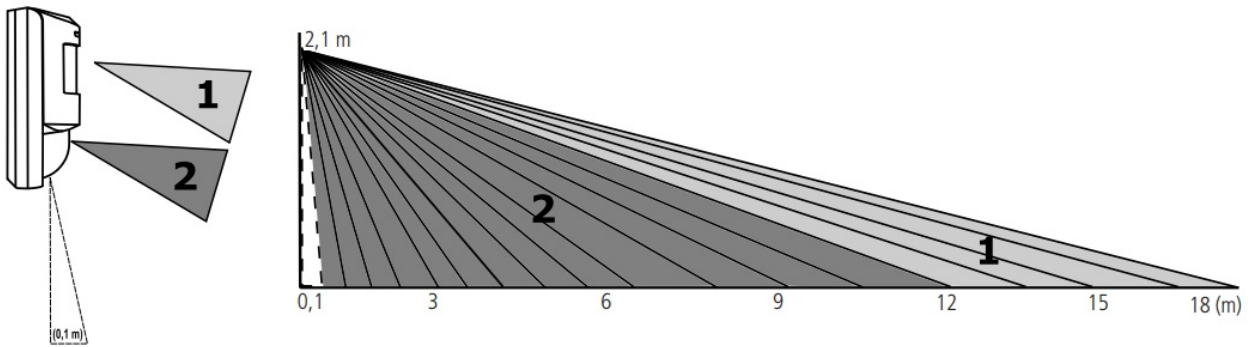

Technical specifications

Operating voltage	9 ~16 Vdc
Operating current	50 mA
Detection angle	110°
Detection range (PIR and MW)	18 meters
Detection method	Microwaves and PIR (AND)
Number of pyroelectric sensors	2
Pyroelectric sensor type	Quad
Microwave frequency	10,525 GHz
Animal immunity	up to 10 kg
Sensitivity	Automatic (factory default) Minimum
ALARM output	NC, 28 Vdc and 100 mA max.
Anti-violation	Rear tamper
LED indicators	LED: Yellow (PIR) Red (MW) Blue (Alarm)
Startup time	60 seconds
Relay opening time	3 seconds
Operating Temperature	-10 °C to 50 °C
Recommended installation height	2.1 meters
Dimensions (W × H × D)	67 × 134 × 54 mm
Weight	134 g

Características

- Anti-camouflage;
- Anti-tamper (tamper key);
- Look down (creeping zone);
- Automatic temperature compensation;
- RFI/EMI immunity;
- Automatic adjustment of infrared sensitivity (PIR);
- Microwave sensitivity adjustment (MW);
- Immunity to creeping animals weighing less than 10 kg;
- Ease of installation;
- Mechanical protection of the electronic circuit.

Product

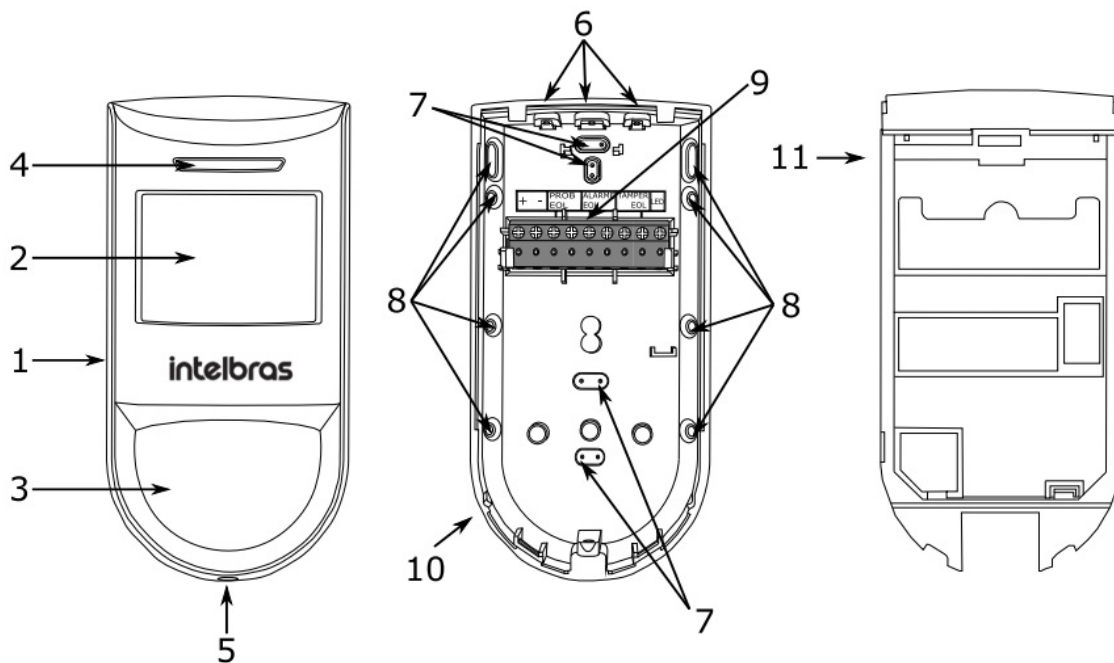

1. Front cover
2. Flat lens
3. Hemispherical lens
4. LEDs
5. Closing screw
6. Wire passage seals
7. Seals for wall installation
8. Seals for corner installation
9. Connector
10. External base
11. Internal base

Board

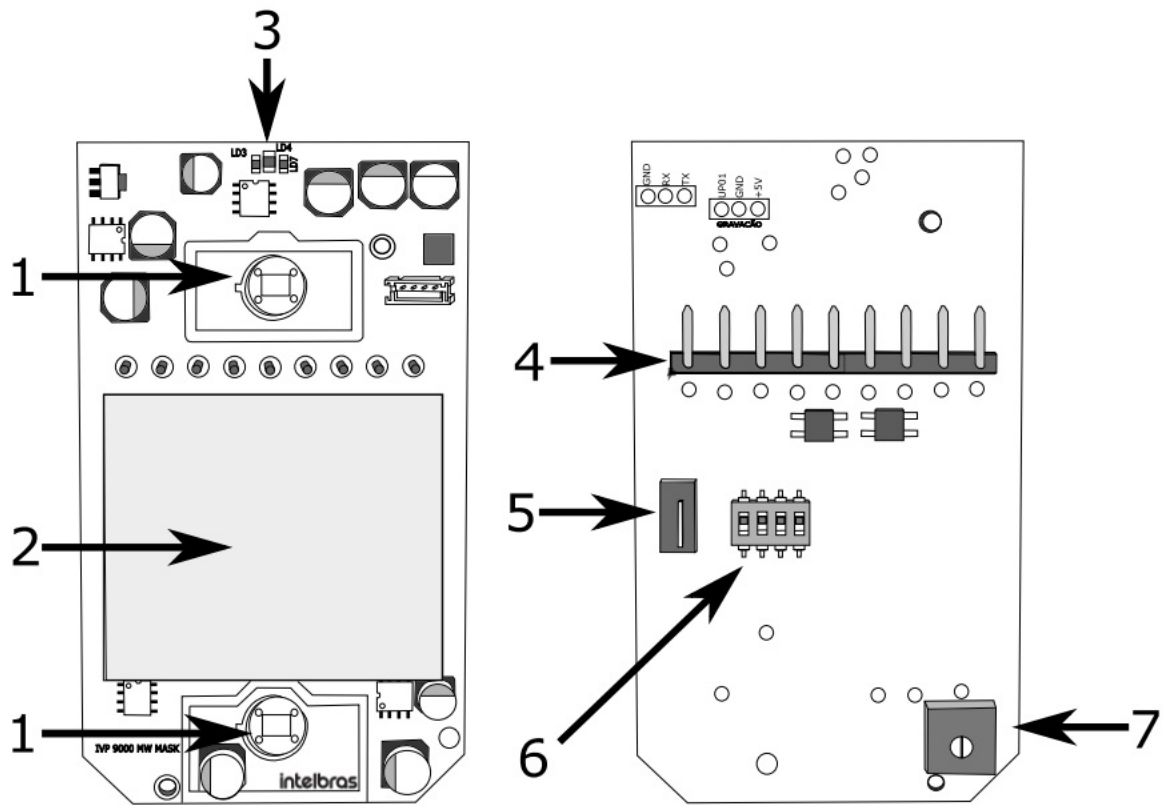

- 12. Pyro sensor
- 13. Microwave module
- 14. LEDs
- 15. Connector
- 16. Tamper key
- 17. 4 position key
- 18. Trimpot microwave adjustment

Installation

- Before starting the installation, it is necessary to define the height at which the sensor will be positioned, which can vary from 2 to 2.4 m;
- Do not install sensors that have microwave technology close to each other, as there may be interference between them;

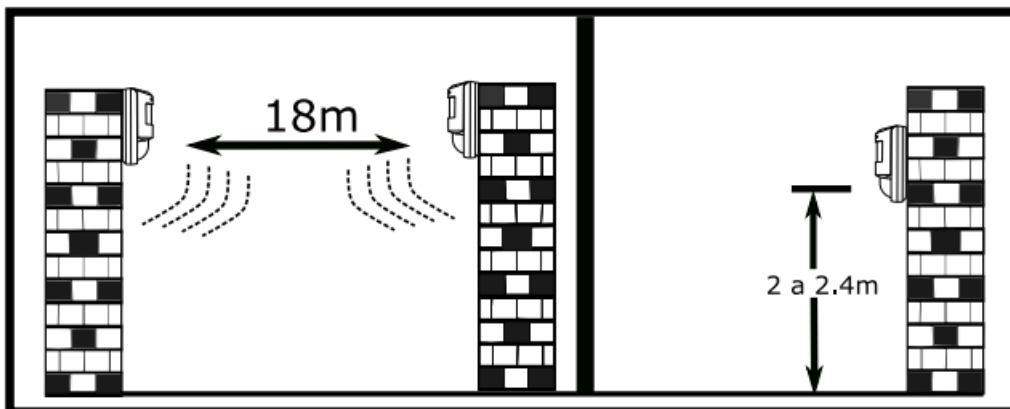

- The microwave sensitivity adjustment must be done according to each environment;
- For installation using the articulator, make sure that both the sensor and the bracket are securely fixed in the

installation location to avoid changes in the product's detection angle. Incorrect use of the articulator can change the sensor's detection area, creating blind spots and impairing operating efficiency;

- If the sensor is installed at an angle, its detection range and PET function may be impaired in such a way as to nullify the function.

To install the sensor, follow the procedure below:

1. Unlock the back cover by partially loosening the screw and remove it by sliding the front cover down, as shown in the picture.

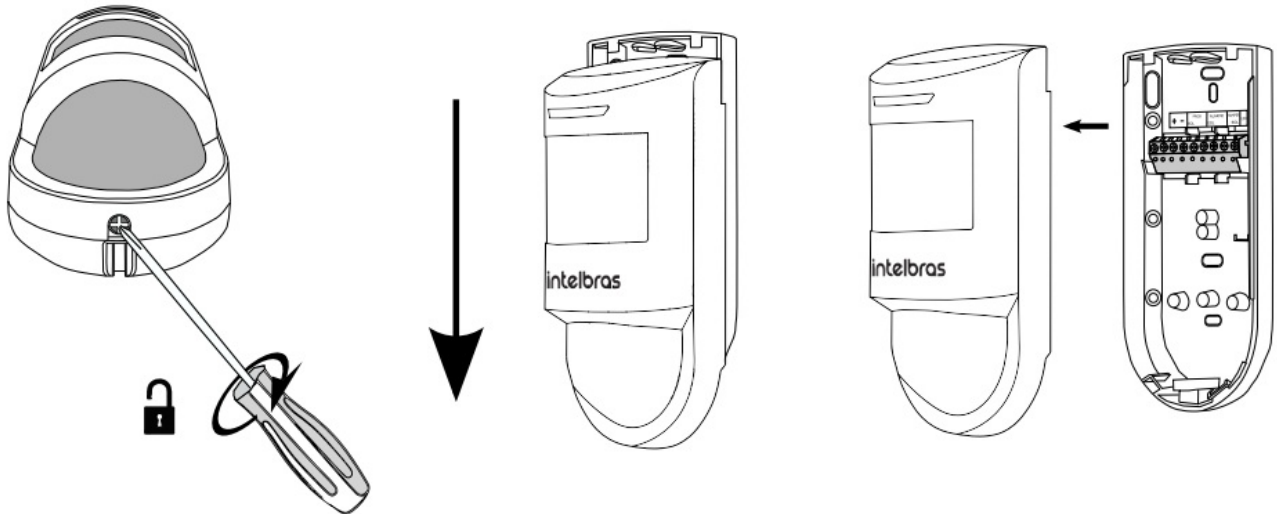

2. Route the wiring through the cable passages located on the sensor back cover.

Note: use a tool to drill the hole in the indicated location.

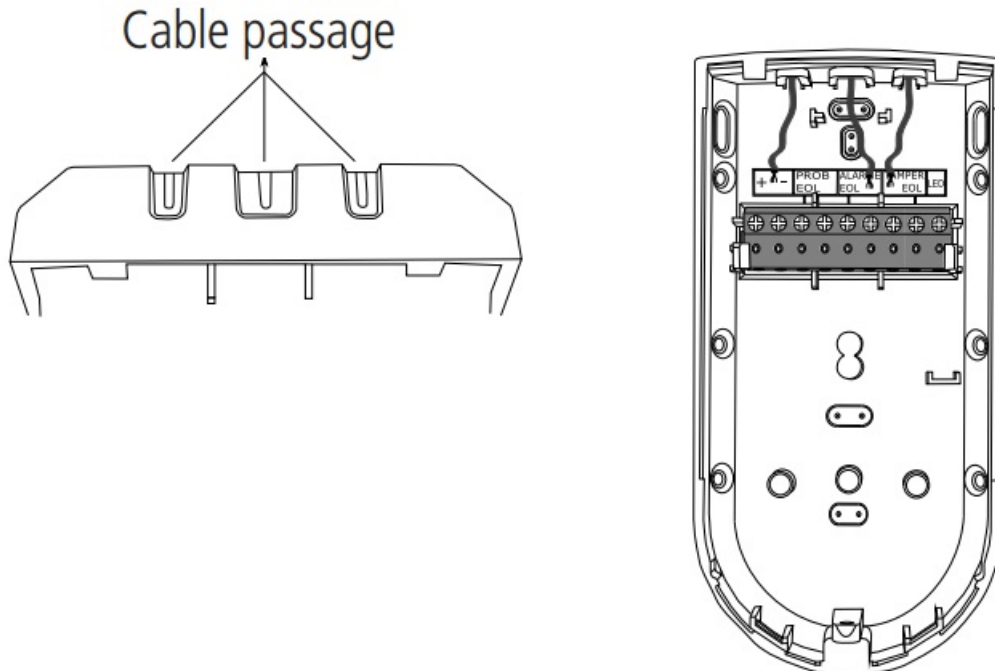

3. Connect the connecting cables to the sensor terminals and install in the place to be protected. For installation directly on the wall, 4x2 box or in a corner of the wall, break the seals indicated for the holes in the rear fixing cover.

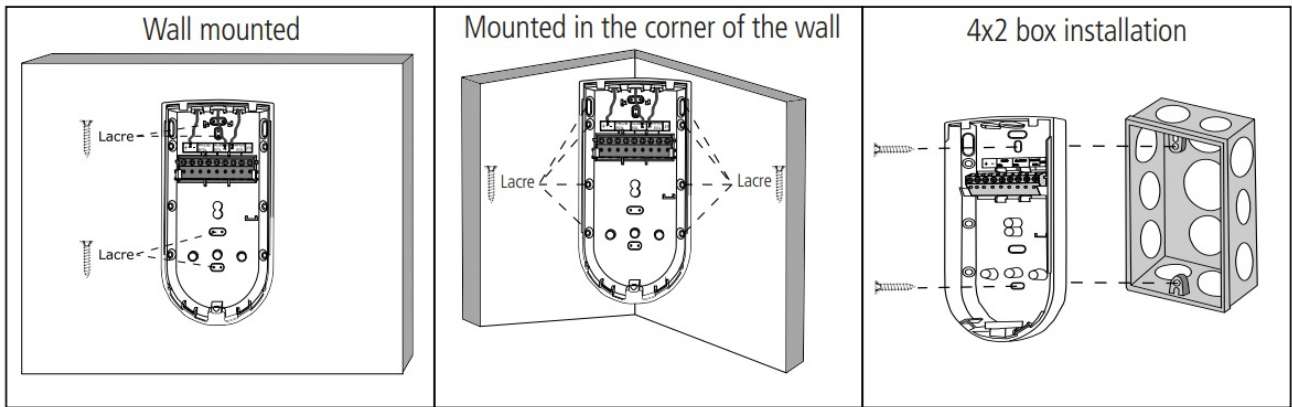

4. Installation using the articulator.

Note: the articulator does not come with the product.

Attention: if the fixing bracket is inclined to the ground, the characteristics of the PET function will change.

Use the fixing holes located on the base to fix the XSA 1000 articulator, for more information about the XSA 1000 articulator, consult the user manual on the website: www.intelbras.com.br

The recommended screw for attaching articulators to the product is 3.5 × 9.5 mm.

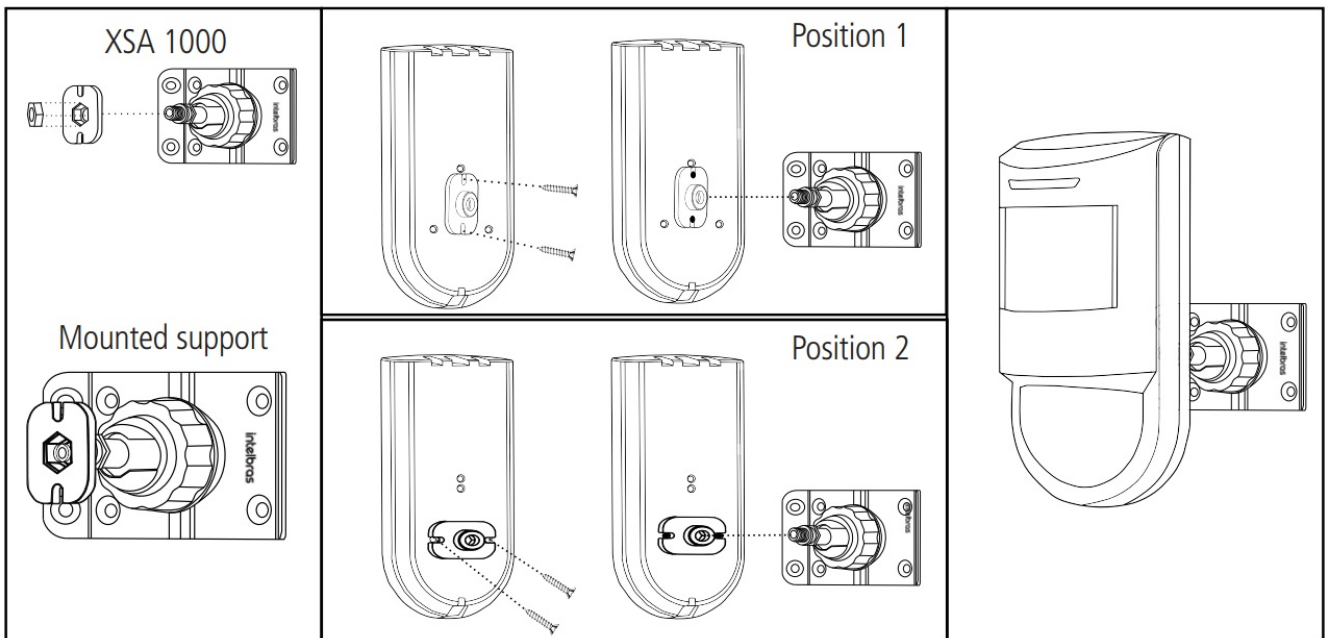

5. Perform the configuration on the sensor following the guidelines.

4.1. Microwave sensitivity adjustment

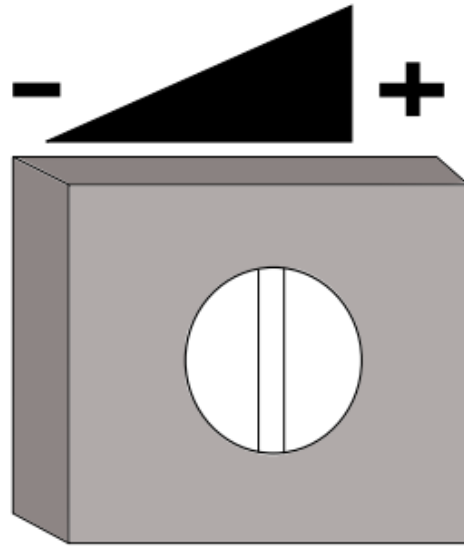

Microwave

The trimpot allows you to adjust the microwave's sensitivity. Turning the trimpot clockwise increases the sensitivity and consequently the distance at which the microwave is able to detect movement. Turning it counterclockwise makes the microwave less sensitive.

Note: it is highly recommended to adjust the microwave sensitivity so that detection takes place only in the environment where the sensor is installed. This technology is capable of detecting movement through a wall, for example.

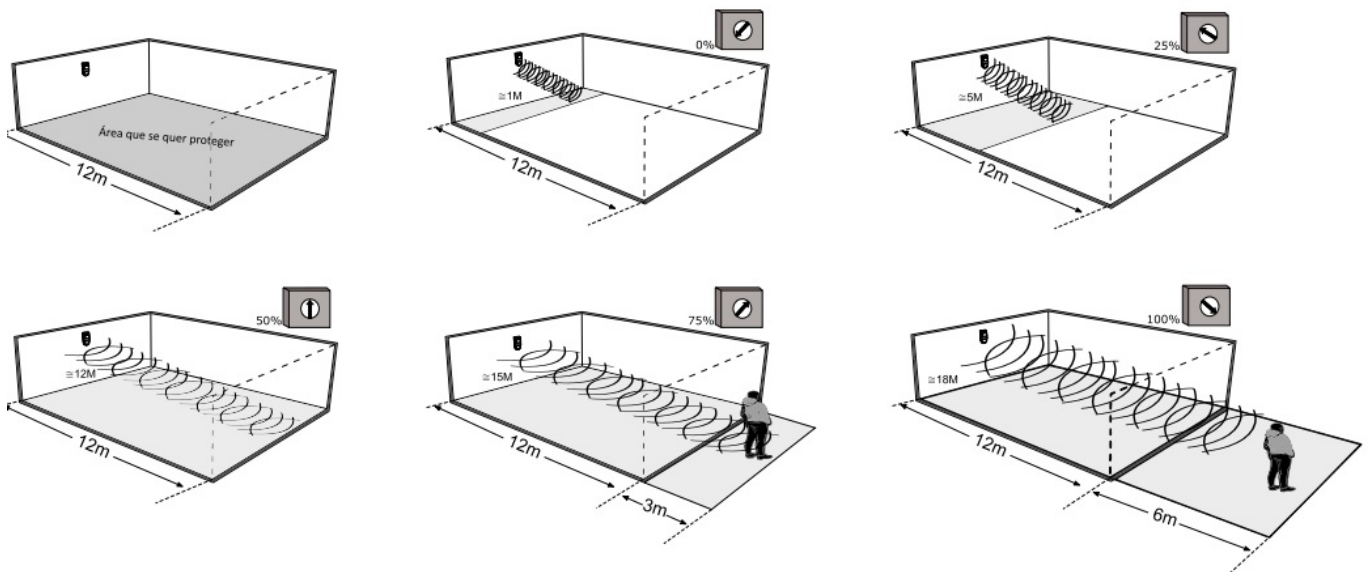

In figure 1 of the example above we have the area we want to protect. Figures 5 and 6 indicate that the trimpot adjustment exceeded the limits of the environment to be protected. In this way the microwave will detect movements outside the desired area.

To make it easier to adjust the microwave cover, adjust the trimpot counterclockwise (less sensitive) and walk in the room you want to protect. Observe the sensor motion detection. If necessary, increase the sensitivity (clockwise). Repeat this process until the sensor only protects the environment where it is installed.

The figure below shows a microwave channel detection range reference.

Factory default: 50%

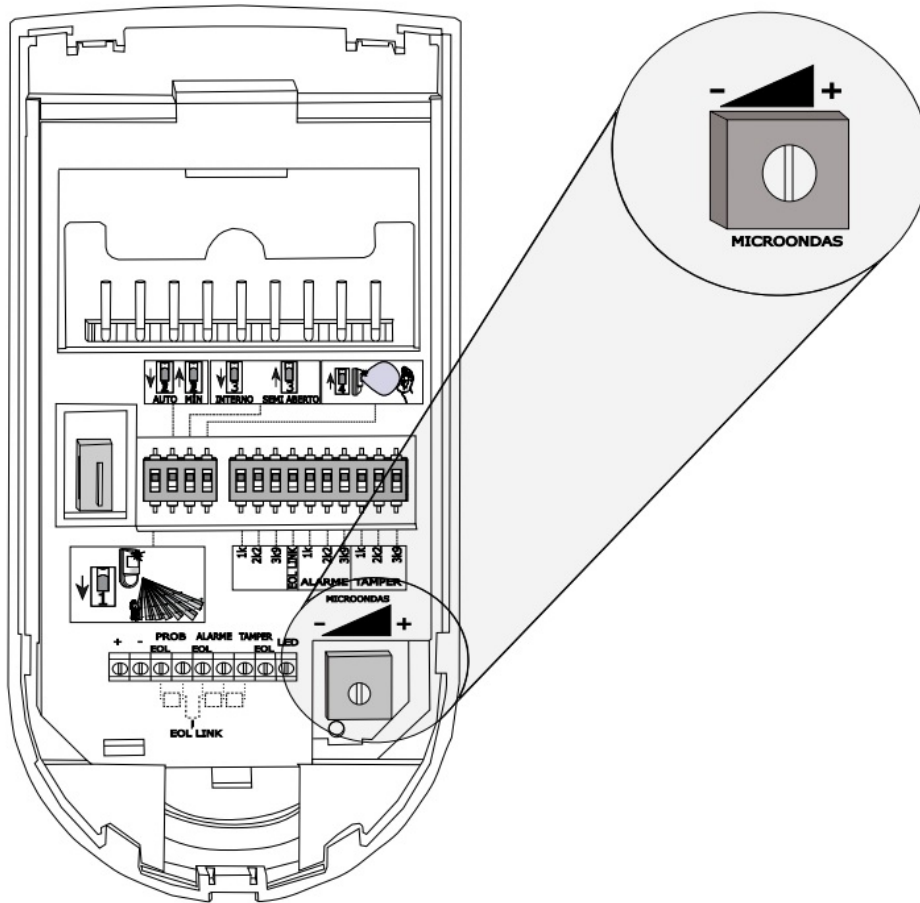

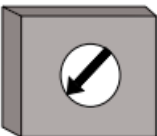
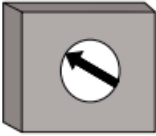
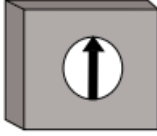
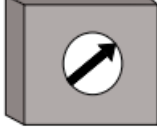
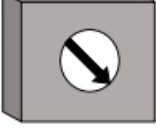
Microwave range	
Trimpot position	Maximum distance
0% 	0% up to 1 meter
25% 	25% up to 5 meters
50% 	50% up to 12 meters
75% 	75% up to 15 meters
100% 	100% up to 18 meters

4.2. Operating mode settings

The key (S1) allows you to configure the sensor's operating mode:

Key 1 – LED: works in conjunction with the LED input to control the visual indication of motion detection.

LED		
Key 1	LED input	LEDs
Condition		Result
ON	12 Volts	LEDs on
OFF	0 Volts	LEDs on
ON	0 Volts	LEDs off
OFF	12 Volts	LEDs off

Factory default: LEDs on.

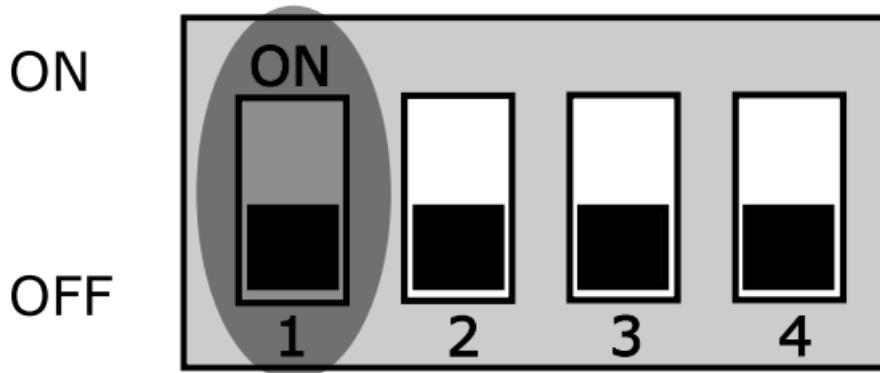

Key 2 – SENSITIVITY: controls the sensitivity of the two PIR channels to trigger the alarm. With the switch in the ON position, the sensitivity is configured in order to avoid trips with little movement, that is, minimum sensitivity. This setting is suitable for semi-open environments or environments with some interference that could cause unwanted triggering.

With the key in the OFF position, the sensitivity remains with automatic adjustment and is controlled through an algorithm that analyzes the conditions of temperature, light and movement of the environment.

SENS	
Position	Condition
ON	Minimum sensitivity
OFF	Automatic

Factory default: Automatic.

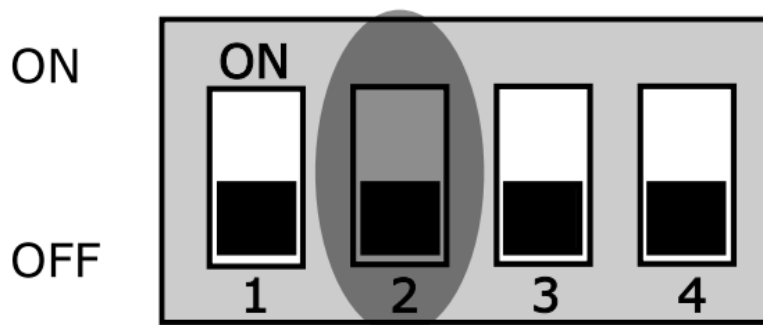

Key 3 – LOCAL: controls the sensor operation settings according to the installed environment. With the key in the ON position, the sensor adjusts the operating mode and sensitivity for a semi-open environment.

Note: with this configuration the sensor does not detect camouflage attempts.

With the key in the OFF position, the sensor adjusts its operating mode to an indoor environment..

Local	
Position	Con
ON	Semi
OFF	Inte

Factory default: Internal.

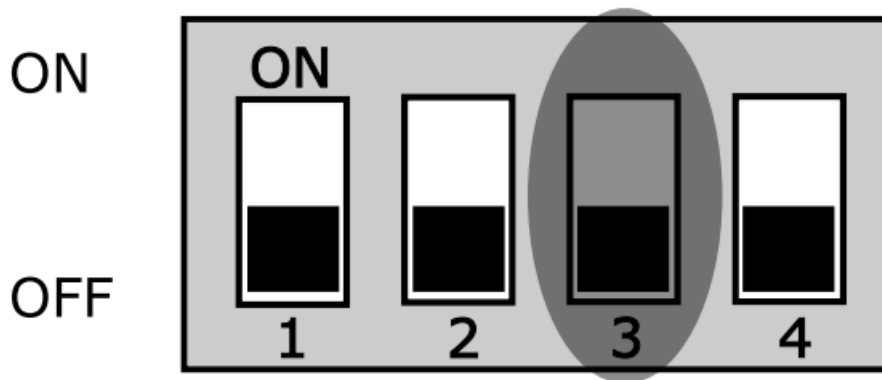

Key 4 – ANTI-CAMOUFLAGE: the IVP 9000 MW is capable of detecting movements even if the individual uses some material to camouflage body temperature. With the key in the ON position, anti-tamper is enabled. With the key in the OFF position, anti-tamper remains disabled.

Anti-camouflage	
Position	Cc
ON	E
OFF	D

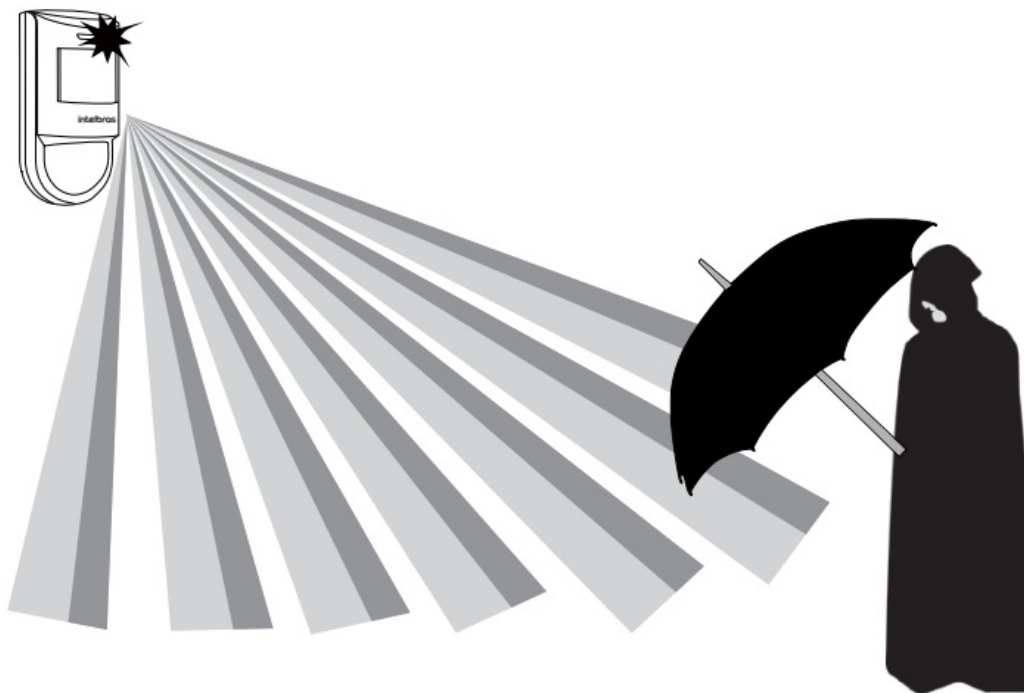
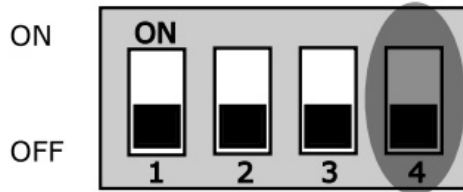

4.3. Process completion

Once the sensor is configured, close it by sliding up the front case on the back cover and tighten the screw.

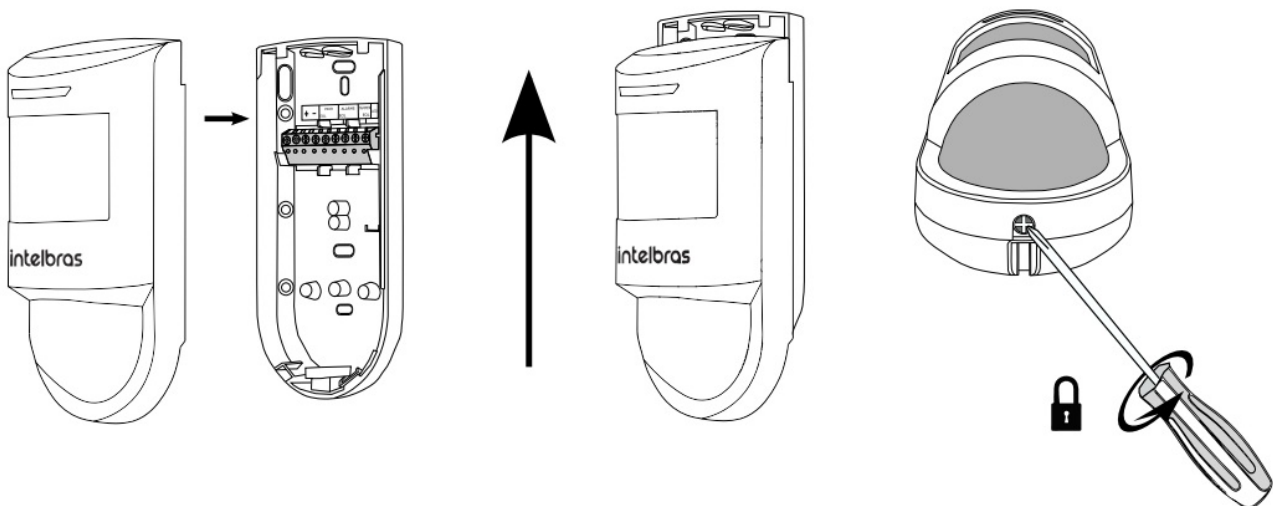

Operation

When turning on the sensor, the blue LED flashes for approximately 60 seconds. This time is necessary for the stabilization of the circuits that make up the sensor. After this period, if they are enabled, the LEDs light up with each motion detection.

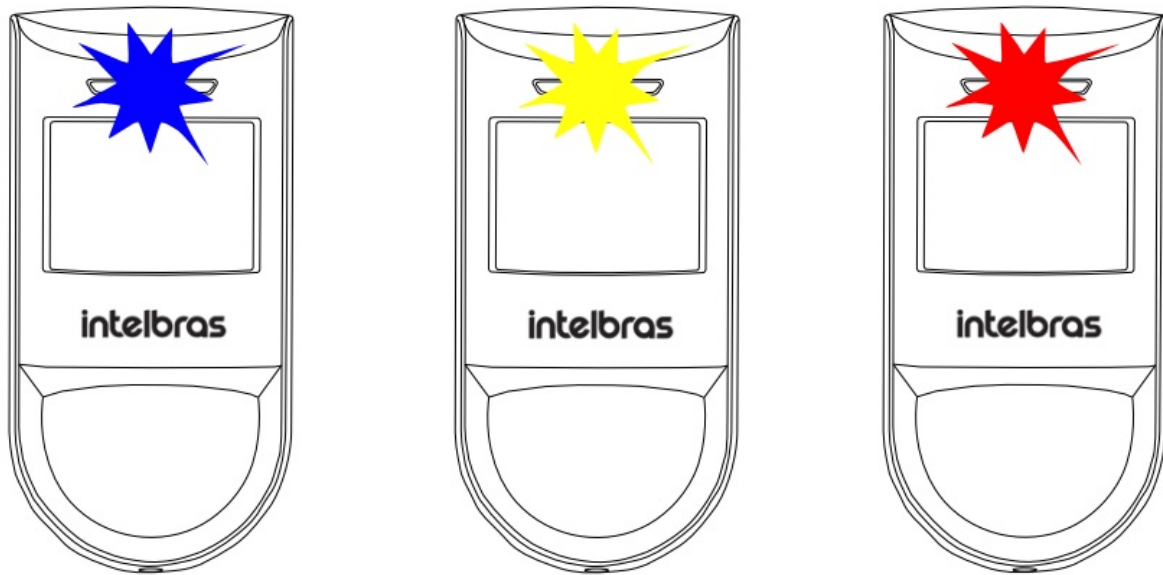

- Blue LED: alarm
- Yellow LED: Pir
- red LED: microwave

Test

Once installed and running, walk across the area to be protected, simulating a possible intrusion into the environment. See if the sensor is able to detect your movements during the journey, through the LEDs. Adjust the microwave's sensitivity to the size of the room or reposition the sensor. Be sure to take all precautions and follow the installation recommendations to obtain the best operating performance from the product.

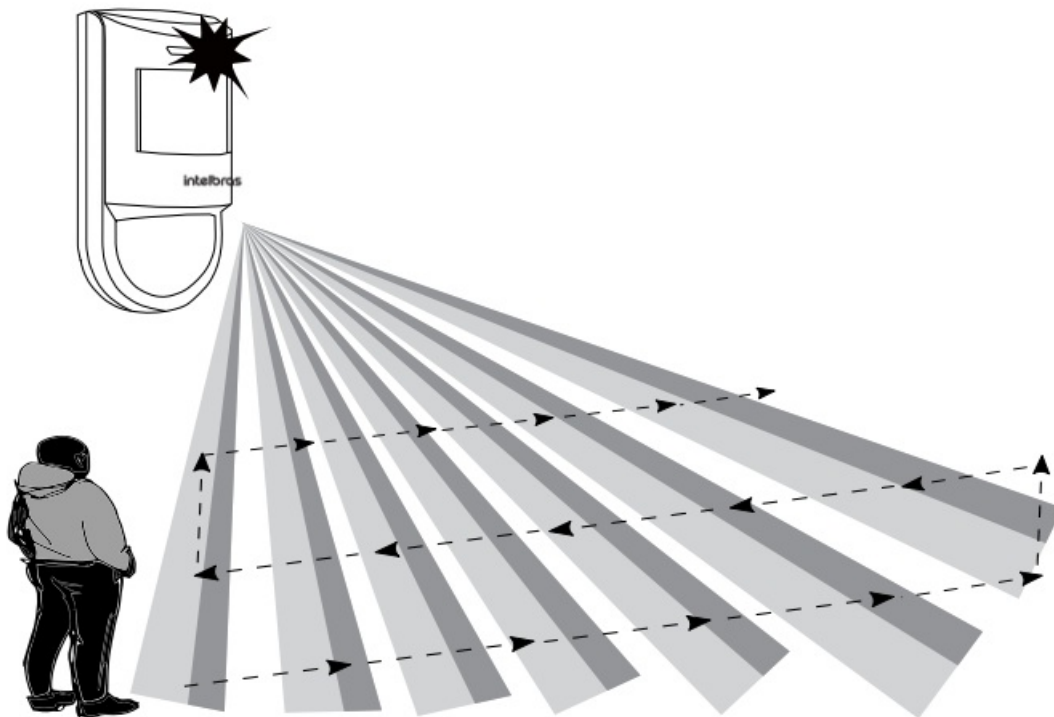

Homologation

This equipment is not entitled to protection against harmful interference and may not cause interference to duly authorized systems. This is a product approved by Anatel, the approval number can be found on the product label, for queries, visit the website: sistemas.anatel.gov.br/sch.

Warranty term

It is established that this warranty is granted upon the following conditions:

Client's name:

Client's signature:

Invoice number:

Date of purchase:

Model:

Serial number:

Retailer:

1. All the parts, pieces and components of the product are guaranteed against possible manufacturing defects, which may arise, for the term of 1 (one) year – this being 90 (ninety) days of legal guarantee and 9 (nine) months contractual warranty –, counting from the date of purchase of the product by the Consumer, as appears in the product purchase bill of sale, which is an integral part of this Term throughout the domestic territory. This contractual warranty includes the free exchange of parts, pieces and components which have a manufacturing defect, including the expenses with labor used in this repair. If there is no manufacturing defect, but defect(s) arising from misuse, the Consumer shall bear these expenses.
2. The installation of the product shall be executed in accordance with the Product Manual and/or Installation Guide. If your product requires the installation and configuration by a qualified technician, seek a suitable specialized professional, the costs of these services not being included in the product amount.
3. Having perceived the defect, the Consumer shall immediately contact the nearest Authorized Service which appears in the report offered by the manufacturer – they are the only ones authorized to examine and remedy the defect during the warranty term foreseen herein. If this is not respected, this warranty shall lose its validity, as it shall be characterized as product infringement.
4. If the Consumer requests home service, it shall contact the nearest Authorized Service to inquire about the technical visit rate. If it is necessary to remove the product, the ensuing expenses, such as those of transportation and insurance of the taking and return of the product, shall be the Consumer's responsibility.
5. The warranty shall lose its validity totally in the occurrence of any of the following cases: a) if the defect is not one of manufacture, but is caused by the Consumer or by third parties foreign to the manufacturer; b) if the damage to the product arises from accidents, disasters, agents of nature (lightning, floods, landslides, etc.), humidity, voltage in the electrical network (excess voltage caused by accidents or excessive fluctuations in the network), installation/use in disagreement with the user's manual or arising from natural wear of the parts, pieces and components; c) if the product has undergone effects of a chemical, electromagnetic, electrical or animal (insects, etc.) nature; d) if the serial number of the product has been falsified or erased; e) if the appliance has been infringed.
6. This warranty does not cover loss of data; therefore, it is advisable that if it is the case of the product, the Consumer makes a backup regularly of the data which appears in the product.
7. Intelbras is not responsible for the installation of this product, or for possible attempts at fraud and/or sabotage in its products. Maintain the updates of the software and applications used up-to-date, if it is the case, as well as the network protection required for defense against hackers. The equipment is guaranteed against defects in its usual conditions of use, it being important to bear in mind that, as it is electronic equipment, it is not free of fraud and scams which may interfere with its correct functioning.
8. After its useful life, the product must be delivered to an authorized Intelbras service center or directly disposed of in an environmentally appropriate manner to avoid environmental and health impacts. If you prefer, the battery, as well as other unused Intelbras brand electronics, can be disposed of at any Green Eletron collection

point (waste management facility to which we are associated). If you have any questions about the reverse logistics process, please contact us at (48) 21060006 or 0800 704 2767 (Monday to Friday 8am to 8pm and Saturdays 8am to 6pm) or via -mail support@intelbras.com.br.

These being the conditions of this complementary Warranty Term, Intelbras S/A reserves the right to alter the general, technical and esthetic features of its products without prior notice.
All the images of this manual are illustrative.

intelbras



talks to us

Customer Support:  (48) 2106 0006

Forum: forum.intelbras.com.br

Support via chat: chat.intelbras.com.br

Support via e-mail: suporte@intelbras.com.br

Customer Service: 0800 7042767

Where to buy? Who installs it? 0800 7245115

Produced by: Intelbras S/A – Indústria de Telecomunicação Eletrônica Brasileira
Rodovia BR 459, km 124, 1325 – Distrito Industrial – Santa Rita do Sapucaí/MG – 37540-000
CNPJ 82.901.000/0016-03

www.intelbras.com.br

www.intelbras.com

01.22

Made in Brazil

Documents / Resources

	<p>intelbras IVP 9000 MW Passive Infrared Motion Sensor [pdf] User Manual IVP 9000 MW, Passive Infrared Motion Sensor, IVP 9000 MW Passive Infrared Motion Sensor, Infrared Motion Sensor, Motion Sensor, Sensor</p>
---	--

References

- [CHAT Intelbras](#)
- [Fórum Intelbras - Índice](#)
- [SCH](#)
- [Intelbras | Segurança eletrônica, Redes, Comunicação e Energia](#)
- [Intelbras | Segurança eletrônica, Redes, Comunicação e Energia](#)