



HW-group NB-2X1WIRE Temperature and Humidity Monitoring Device User Manual

[Home](#) » [HW group](#) » HW-group NB-2X1WIRE Temperature and Humidity Monitoring Device User Manual 

Contents

- [1 HW-group NB-2X1WIRE Temperature and Humidity Monitoring Device](#)
- [2 Safety Notices](#)
- [3 NB Devices product family](#)
- [4 Overview of NB Devices](#)
- [5 Shared features of the NB-IoT product family](#)
- [6 Measurements and data upload](#)
- [7 Description of HW elements](#)
- [8 Setting up the device](#)
- [9 Migration of the connected device](#)
- [10 Portals where can be devices connected to](#)
- [11 SensDesk.com portal features](#)
- [12 NB-Devices models and their specific features](#)
- [13 Technical specifications](#)
- [14 Mechanical dimensions](#)
- [15 Documents / Resources](#)
 - [15.1 References](#)
- [16 Related Posts](#)



HW-group NB-2X1WIRE Temperature and Humidity Monitoring Device



Safety Notices

The device complies with regulations and standards in force in the Czech Republic and the European Union. The device has been tested and is supplied in working order. To keep the device in this condition, it is necessary to adhere to the following safety and maintenance instructions.

Using the device in a manner other than prescribed by the manufacturer may cause its safeguards to fail!

The power supply outlet or disconnection point must be freely accessible.

The device must not be used in particular under any of the following conditions:

- The device is noticeably damaged
- The device does not function properly
- Unfastened parts can move inside the device
- The device has been exposed to moisture or rain
- The device has been serviced by unauthorized personnel
- The power adapter or power supply cable are noticeably damaged
- If the device is used in a manner other than designed for, the protection provided by the device may fail.
- The local electrical system must include a power switch or a circuit breaker and overcurrent protection.

The manufacturer warrants the device only if it is powered by the supplied power adapter or an approved power supply.

If you have any problems with installing or operating the device, please contact the technical support:

HW group s. r. o.

<http://www.hw-group.com>

email: support@HWg.cz

Formanská 296

Prague, 149 00

Phone: +420 222 511 918

Before contacting technical support, please have at hand the exact type of your device (at the type plate) and, if known, the firmware version (see later in this manual).

NB Devices product family

NB Devices is a family of environment monitoring products that use the Narrowband (NB-IoT) mobile network. All products feature robust design, battery-powered operation, and seamless integration with the SensDesk IoT

portal. All devices include a 3V alkaline CR123A battery that allows continuous operation for about 3 years (depending on the device type, application and connected sensors).

Overview of NB Devices

- **NB-2x1Wire** – A device for connecting thermometers, hygrometers, or other sensors via the 1-Wire bus. Allows connecting two 1-Wire or 1-Wire UNI sensors to measure up to 4 quantities simultaneously.
- **NB-2xIn** – A device for connecting a door or window contact, a PIR motion detector or a smoke or gas detector with a dry contact output. Allows connecting 2 independent detectors. Inputs can feature pulse counters for connecting energy meters with S0 output; however, external power is needed for reliable deployment.
- **NB-WLD** – Water leak detector with a moisture-sensing cable. Allows connecting 1 sensing cable of up to 60m length.
- **NB-2xOut** – A module with 2 relay outputs controlled from the SensDesk portal over the NB-IoT network.

Shared features of the NB-IoT product family

- Robust metal design, 67 × 78 × 33 mm
- External antenna, SMA connector
- 4FF (nano SIM) holder
- LED indicator
- Plug&Play – connect power or remove the insulating strip and the device is immediately available in the portal
- All settings (data upload period, safe ranges) are configured in the portal
- Battery state appears in the portal as another sensor
- Powered from a 5V adapter or the built-in replaceable CR123A battery

For specifics of individual devices, including any differences in the measurement period, battery life and so on, see the respective device page.

Measurements and data upload

Measurement and data upload period

The period for logging the measured values and uploading them to the portal is configured automatically via the portal, separately for operation with an external power source and battery-powered operation. At the time of this writing, the following values were valid for the SensDesk portal:

External power

- Logging period (measuring, storing values in the internal memory): 5 minutes
- Data upload period (connecting to the portal and uploading all logged values): 1 hour
- Check period (NB-2xOUT brief query for output state changes): 10 minutes

Battery power

- Logging period (measuring, storing values in the internal memory): 15 minutes
- Data upload period (connecting to the portal and uploading all logged values): 10 hours
- Check period (NB-2xOUT brief query for output state changes): 1 hour

Only the server administrator may change these periods. In justified cases, individual changes can be agreed with the server administrator. However, keep in mind that if the periods are shortened, battery life may be very negatively impacted. In any case, the data upload period cannot be shorter than 60 minutes and the logging period shorter than 5 minutes.

Periodic and non-periodic reading of sensors

Sensors values are regularly read in the fixed Log Period, which is configured via the SensDesk portal. However, in addition to the periodic reading, the values can be also read if the following happens:

1. The device is powered up by connecting the battery or an external power supply
2. The button is pressed
3. If the SafeRange is exceeded at the moment of periodic reading, the measurement is repeated after the Delay interval

Periodic and non-periodic data upload

Sensor values are uploaded to the server periodically in the fixed period, which is configured via the SensDesk portal. However, in addition to the periodic upload, data can be also uploaded if the following happens:

1. SIM card is inserted
2. Device power is connected or changed
3. The button is pressed
4. SafeRange is exceeded (if the Delay is set, then only after the Delay elapses)

SafeRange – range of allowed values

SafeRange is configured in the SensDesk portal separately for each sensor. Whenever the measured value is outside of this range, a message is sent. (However, keep in mind that in order to extend battery life, sensors are only read in the Log period. With the exception of SD-2xIN, sensors are NOT read at other times.) If a Delay is set together with the SafeRange, the repeated measurement is performed at the next Log period, and an Alarm is raised only if the repeated measurement is also out of the SafeRange.

Hysteresis / Idle range

The Hysteresis setting defines a tolerance band for suppressing alarm alerts. The function prevents multiple alarm alerts if the reading oscillates around the specified threshold. The range is configured independently for each sensor.

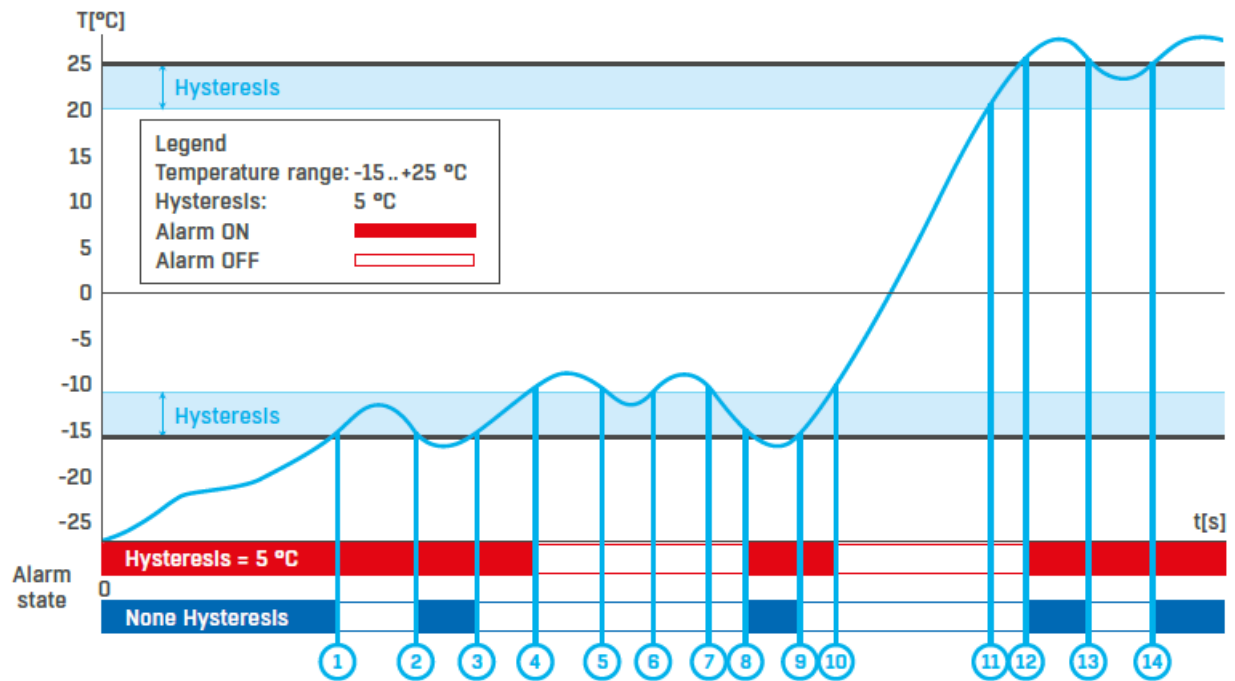

The figure demonstrates two cases. Without the hysteresis idle range of 5 °C, the alarm raised in point 8 would end in point 9; however, the hysteresis function keeps the alarm active until the temperature reaches the upper limit of the tolerance band (point 10): $5\text{ °C} + (-15\text{ °C}) = -10\text{ °C}$.

- Hysteresis = 5°C – The unit sends 3 e-mail (SMS) messages. Alarm active in points 0..4, 8..10, 12 and beyond.
- No hysteresis (0°C) – The unit sends 8 e-mail (SMS) messages. Alarm active in points 0..1, 2..3, 8..9, 12..13, 14 and beyond.

In determining when the Alarm ends, the Hysteresis value applies. The end of an Alarm is only notified when the measured value is well within the SafeRange. However, the value is only read according to the Log Period.

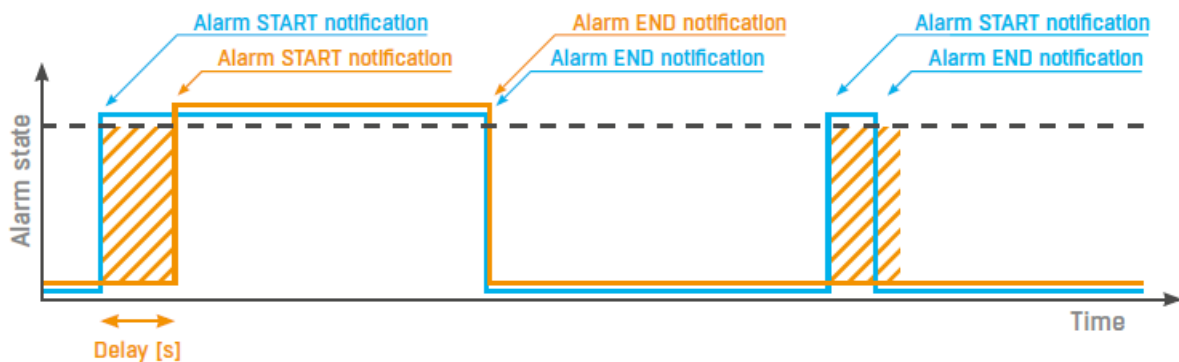

Alarm status notification based on a Delay value:

- Blue: Delay = 0
- Yellow: Delay is non-zero

To increase battery life, be careful when setting the SafeRange and Hysteresis values.

Description of HW elements

LED indicator (Status)

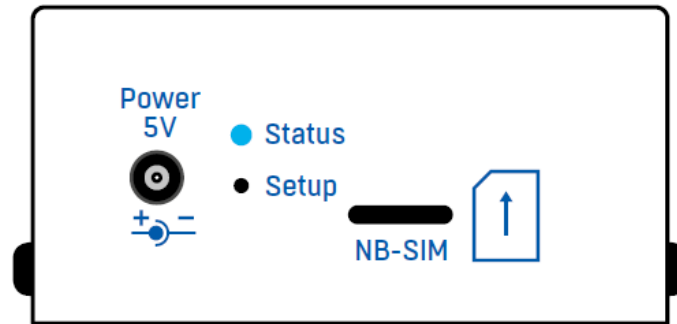

The blue LED gives a quick status indication for debugging and troubleshooting. It can indicate these states:

- Short flash – reading of sensors and inputs
- Rapid flashing – registration to the NB-IoT network
- Continuously on – communication over the NB-IoT network, data transfer

When power is connected to the device, the indicator briefly lights up to indicate modem initialization and 1-Wire sensor detection. Then, it quickly flashes as the device connects to the network, and lights up whenever the device communicates with the portal. It also briefly flashes when the 1-Wire sensors or the WLD cable state are being read.

Setup button

The button is used to send values to the portal immediately and to detect sensors.

- Press – sensors are detected and data are sent to the portal
- Press for longer than 10 s – reset to factory defaults

Setting up the device

1. Attach the external antenna
2. Connect 1-Wire sensors (NB-2x1Wire only)
3. Insert SIM card
4. With a slight force, pull out the insulating strip that insulates the battery from the contacts
5. Connect the external power supply and wait until the device connects to the operator's network (i.e. until the blue LED turns off). Depending on the network and device configuration, this can take up to 20 minutes (when the device is first connected to an operator's network, including in a new country or region). During this time, do not disconnect external power to avoid battery drain.
6. Default portal where are devices connected is www.HWg-cloud.com.

To install new device are 2 options:

- You have existing account on the HWg-cloud and you would like to adopt new device to this one account. (See page 8)
 - You have existing account on another SensDesk technology based portal (www.SensDesk.com or www.HWportal.cz for example) and you would like to migrate new device to this one account. (See page 9)
7. Define sensor name & SD SafeRange for each sensor. (See page 11)

Adopt new device to [HWg-cloud.com](http://www.HWg-cloud.com)

Open the www.HWg-cloud.com website, login to your account and go to the My Team page.

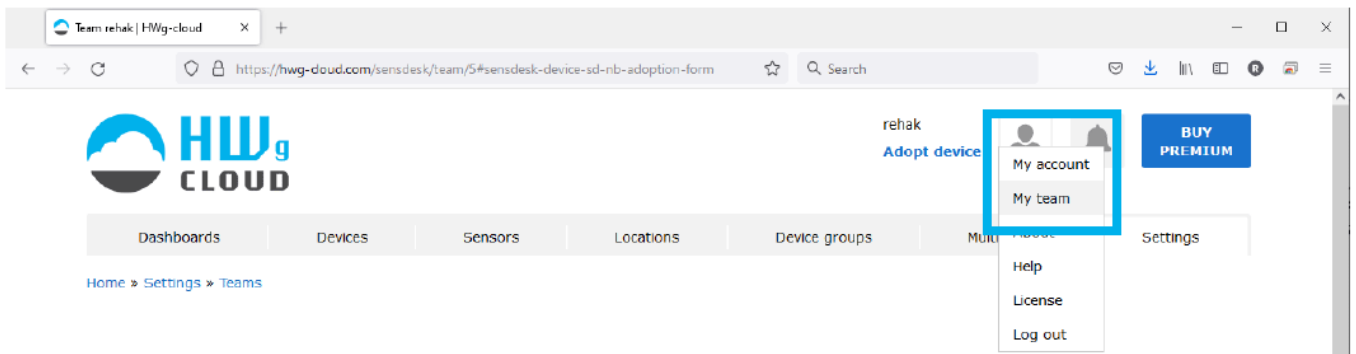

Scroll down to the **Device Adoption**.

Fill the device hash (1234-5678 number on the label of physical device)

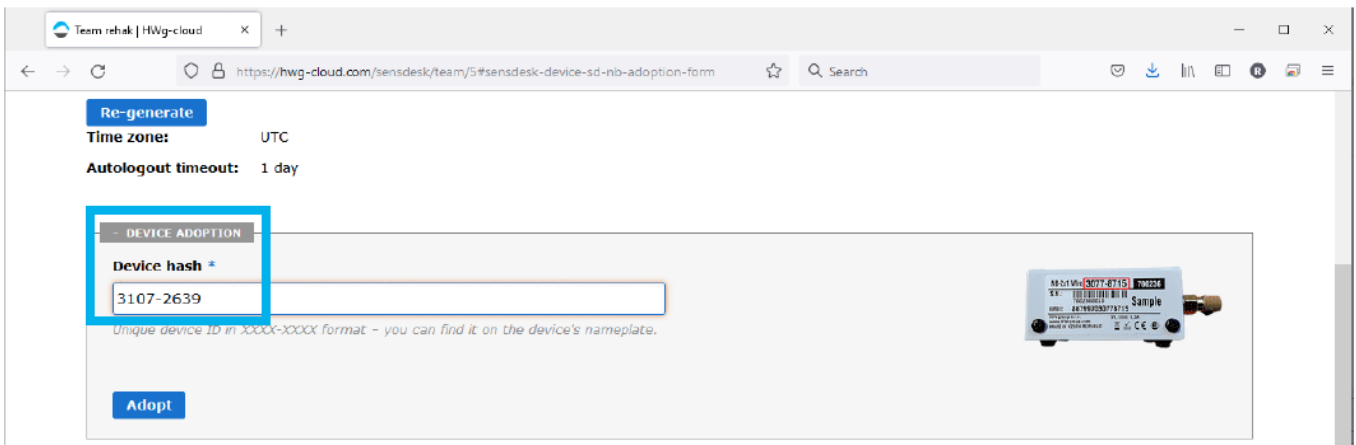

Device will appear after some time in the devices:

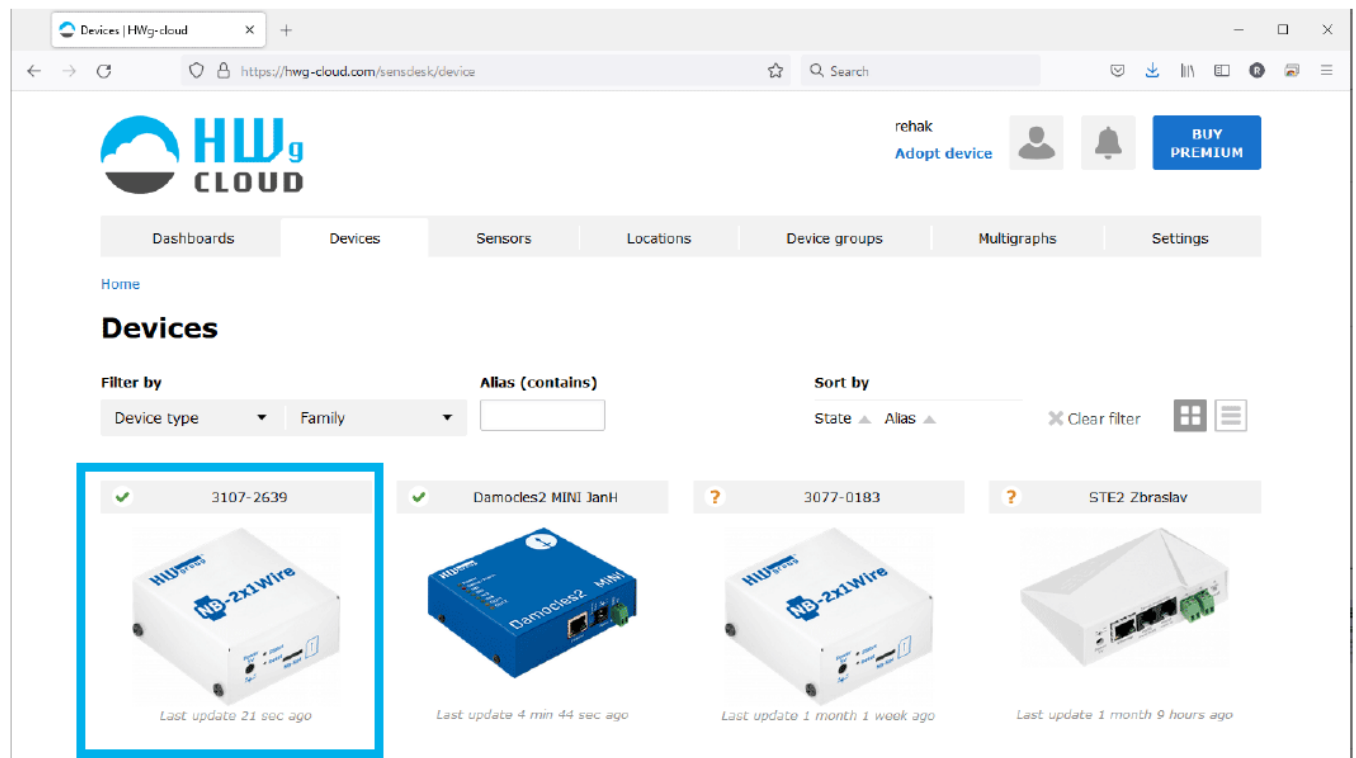

Migrate new device from HWg-cloud.com to another portal

Open the www.HWg-cloud.com website, click to Set Device button on the top of the page.

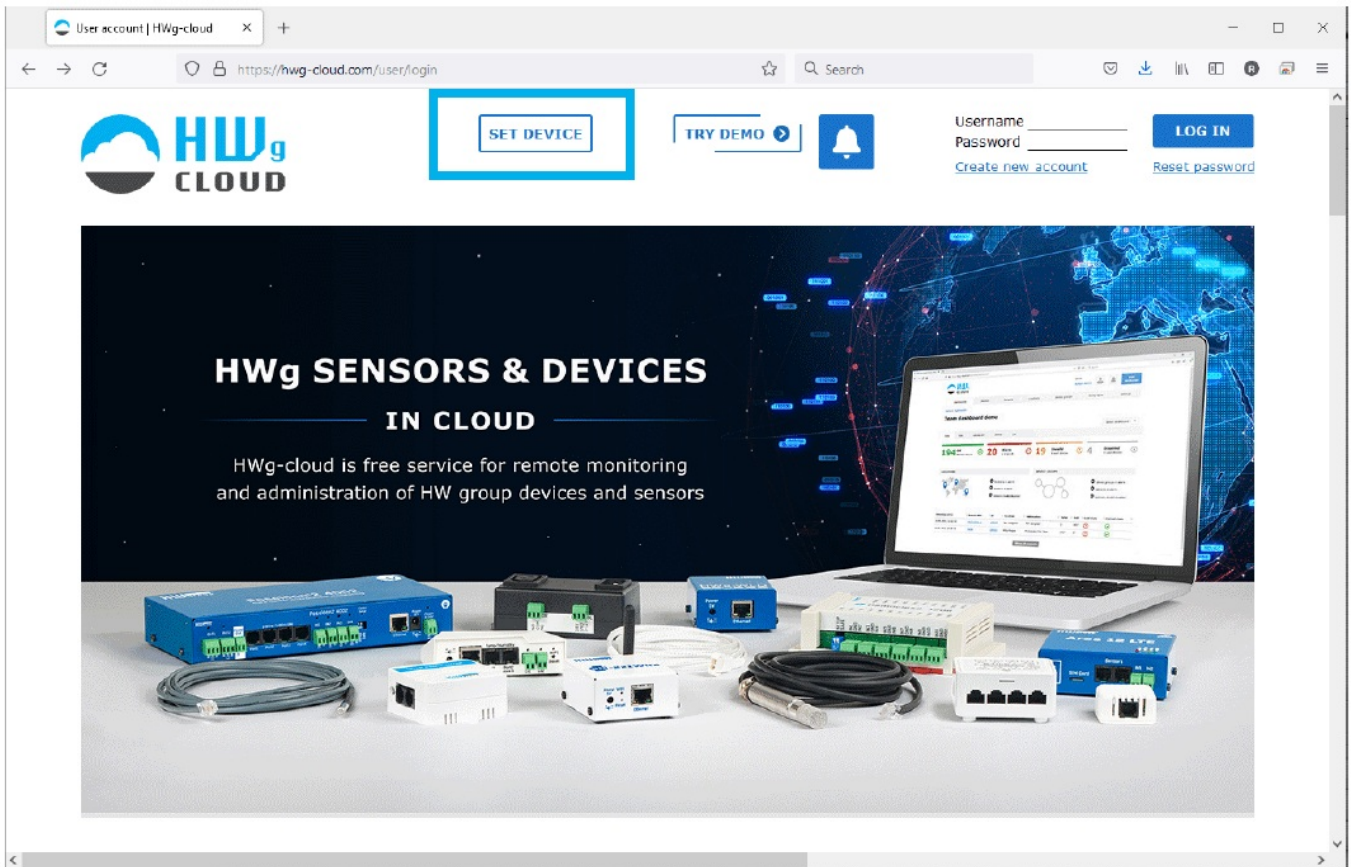

Fill the device hash (1234-5678 number on the label of physical device)

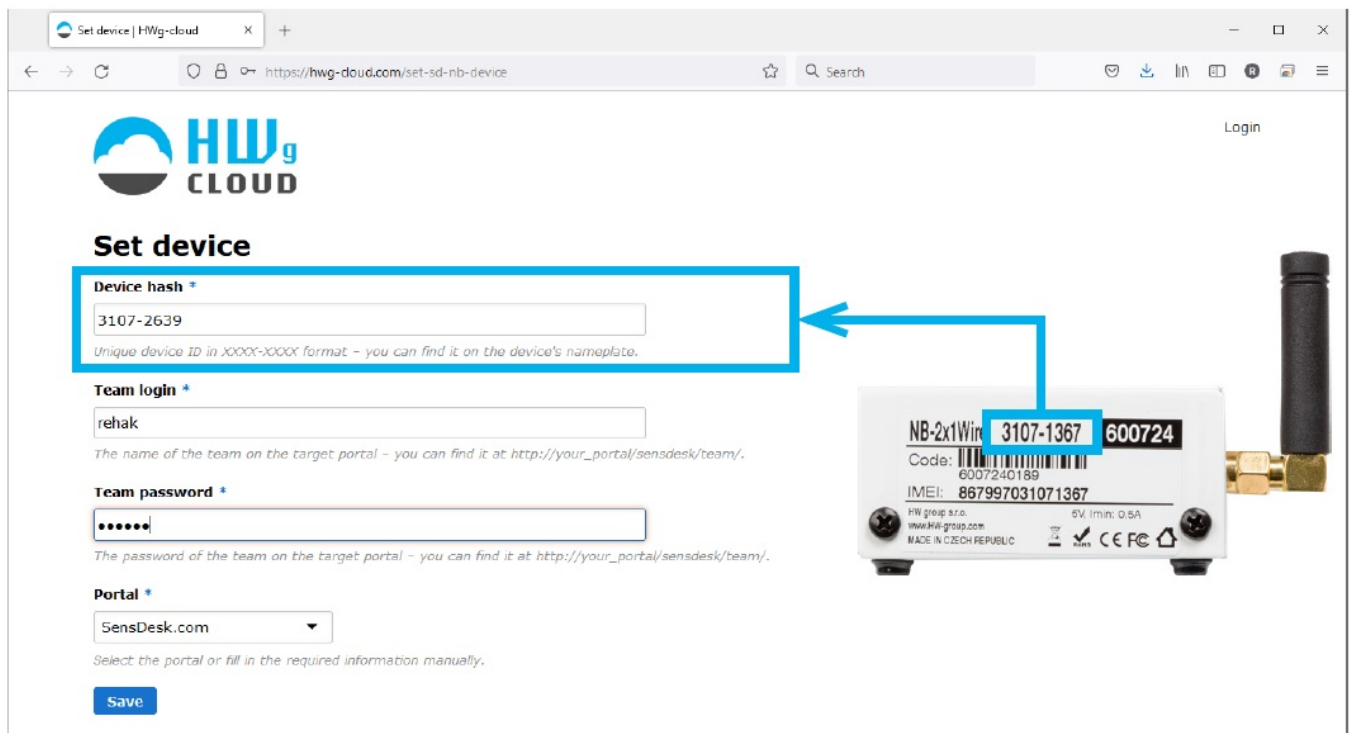

As Team login & Team password fill data from the SensDesk technology based portal, where you have the account. You will find them on the Team page.

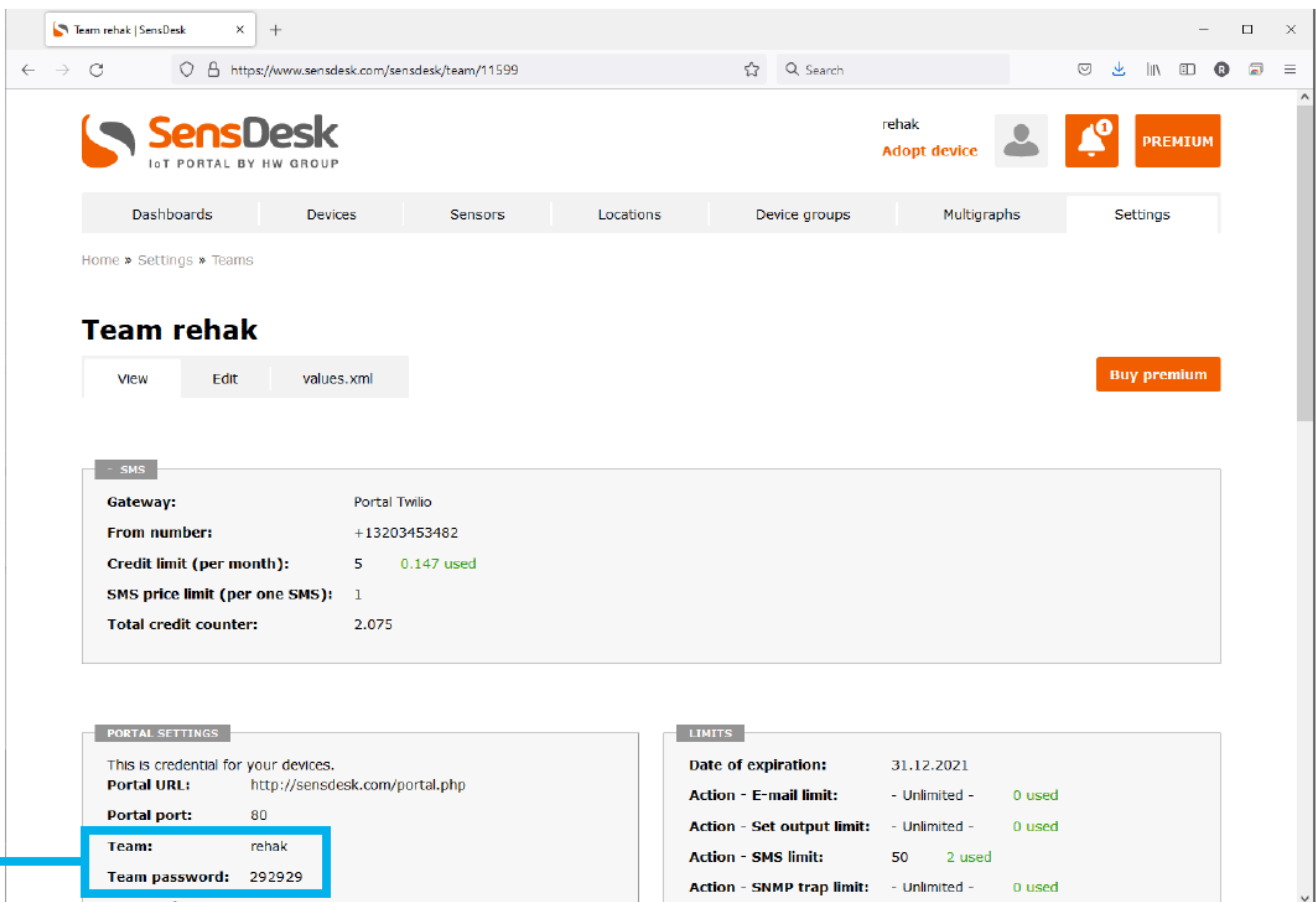
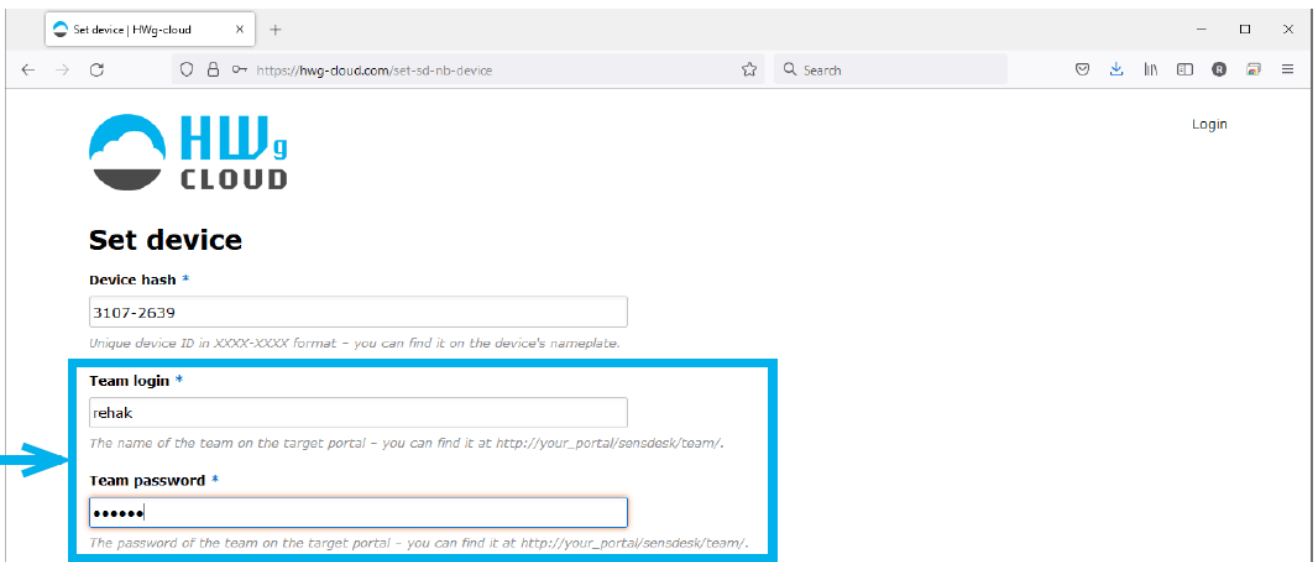

After you click to Save button on the web page, take a pencil or other tool and briefly press the Setup button on the device. It will start blinking (communication with the portal) and finalize device migration process.



Device will appear in the Device list:

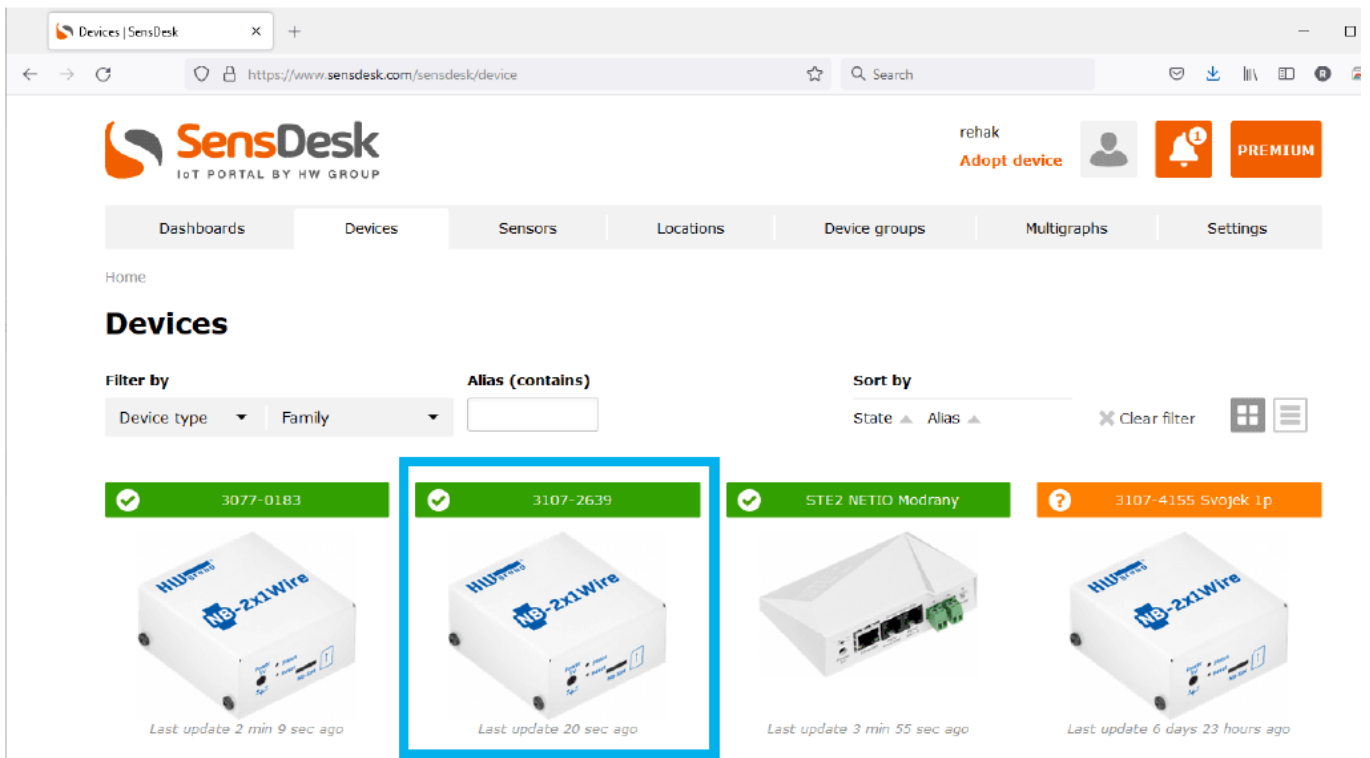

Define sensor name & SD SafeRange for each sensor

Part of the device installation is to define sensor name & SD SafeRange for each sensor. Define SD SafeRange to significantly speed-up alerts when sensor value oscillate around the Safe-Range limit.

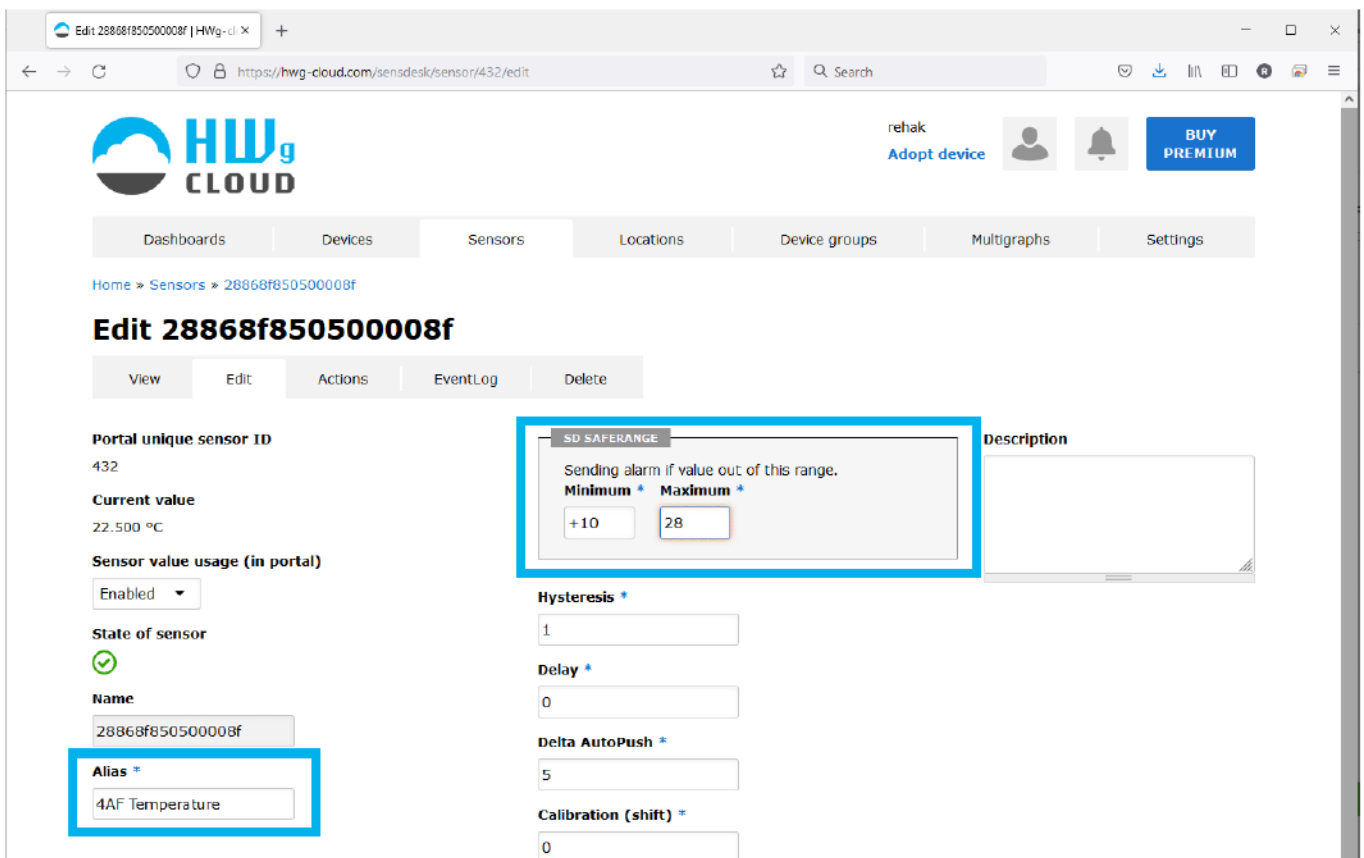

Migration of the connected device

The connected and working device can be also easily migrated from one portal to another. For example in this case from paid portal www.SensDesk.com to free

The screenshot shows the SensDesk IoT portal interface. At the top, there's a navigation bar with the SensDesk logo and user information for 'rehak'. Below the navigation, there's a breadcrumb trail: Home > 3107-2639. The main content area displays device details for '3107-2639', including a 'Last log' status (18.09.2021 01:58) with a green checkmark, and fields for 'Device groups', 'Location', and 'IP Address'. A blue button labeled 'Migrate device to another SensDesk technology based portal' is highlighted. To the right is an image of the 'NB-2x1Wire' device. Below the details are three gauge charts: '28868f850500008f' (Temperature: 22.649°C), 'Battery 3107-2639' (Battery level: -1%), and 'Network Quality 3107-2639' (Network Quality: 3 NQ).

Fill in Team login and Team password, and choose the right SensDesk technology-based portal.

The screenshot shows the 'Migrate device' form in the SensDesk portal. The form has the following fields: 'Device hash' (3107-2639), 'Team login' (rehak), 'Team password' (masked with dots), and 'Portal' (HWg-cloud.com). A 'Save' button is located at the bottom of the form. The page title is 'Migrate device' and the URL is 'https://www.sensdesk.com/set-sd-nb-device?device_hash=3107-2639&destination='.

After you click to Save button on the web page, take a pencil or other tool and briefly press the Setup button on the device. It will start blinking (communication with the portal) and finalize device migration process.

3107-2639 | SensDesk

https://www.sensdesk.com/sensdesk/device/266878

rehak Adopt device PREMIUM

Dashboards Devices Sensors Locations Device groups Multigraphs Settings

Configuration saved. Restart the device or wait for the device to log on.

Home

3107-2639

View Edit Edit sensors Actions EventLog Delete Debug

Last log: 18.09.2021 02:06

Device groups: Not assigned
Location: Not assigned
IP Address: 0.0.0.0
[Migrate to a paid service](#)

28868f850500008f

22.625 °C

Last update 6 min 8 sec ago

Battery 3107-2639

-1 %

Last update 5 min 50 sec ago

Network Quality 3107-2639

2 NQ

Last update 5 min 50 sec ago

Device will appear on the target portal.

Only sensor names will be transferred between the portal. No more device configuration or data history!

Devices | HWg-cloud

https://hwg-cloud.com/sensdesk/device

rehak Adopt device BUY PREMIUM

Dashboards Devices Sensors Locations Device groups Multigraphs Settings

Home

Devices

Filter by: Device type Family Alias (contains) Sort by: State Alias Clear filter

3107-2639

Last update 21 sec ago

Damocles2 MINI JanH

Last update 4 min 44 sec ago

3077-0183

Last update 1 month 1 week ago

STE2 Zbraslav

Last update 1 month 9 hours ago

Portals where can be devices connected to

NB Devices have to be connected to some online Portal based on SensDesk technology.

1. www.HWg-cloud.com is free portal provided by manufacture with limited functions.
2. www.SensDesk.com is paid portal provided by manufacture.

3. Portal providers are independent companies running their own compatible portals. List of them is on the main page of www.HWg-cloud.com.

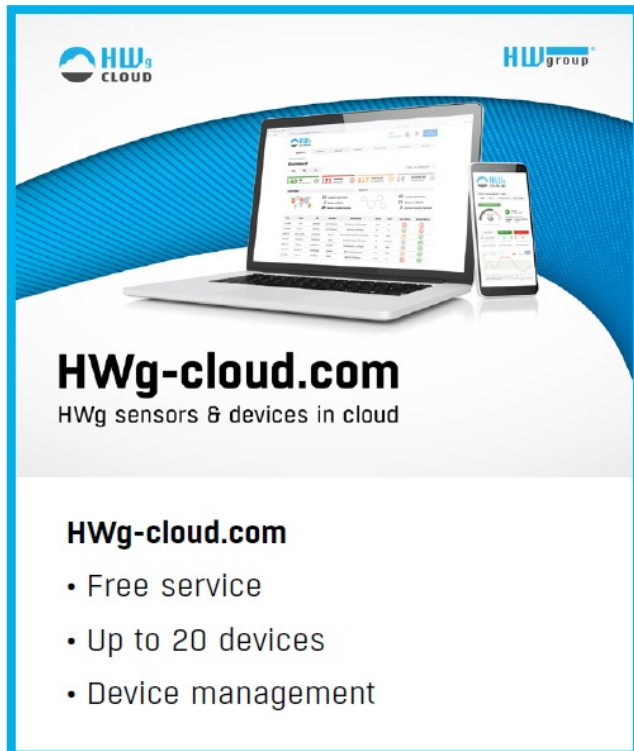

The graphic features a blue background with a white curved surface. A laptop and a smartphone are shown displaying the HWg-cloud.com interface. The HWg CLOUD logo is in the top left, and the HWgroup logo is in the top right.

HWg-cloud.com
HWg sensors & devices in cloud

HWg-cloud.com

- Free service
- Up to 20 devices
- Device management

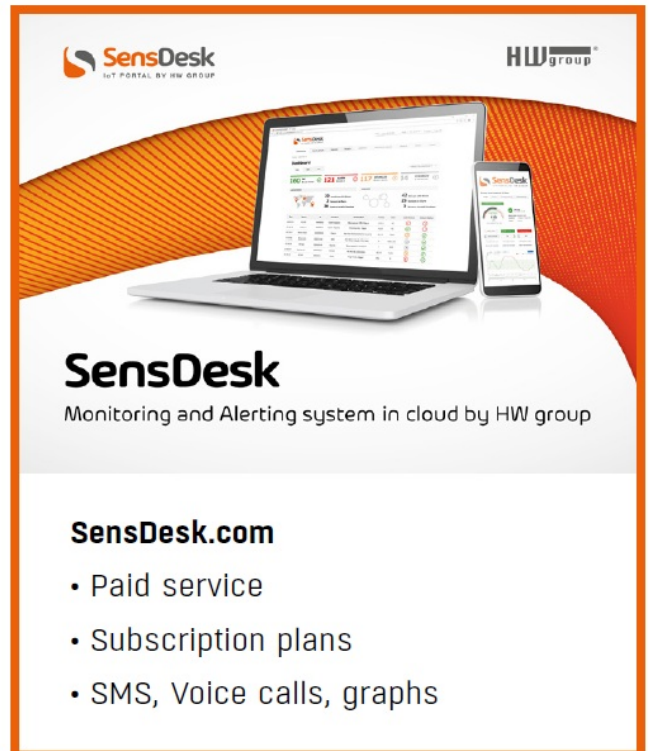

The graphic features an orange background with a white curved surface. A laptop and a smartphone are shown displaying the SensDesk interface. The SensDesk IOT PORTAL BY HW GROUP logo is in the top left, and the HWgroup logo is in the top right.

SensDesk
Monitoring and Alerting system in cloud by HW group

SensDesk.com

- Paid service
- Subscription plans
- SMS, Voice calls, graphs

Portal providers

Do you need advanced features?



SensDesk.com is comprehensive professional system for remote monitoring of your environment.

- Higher device or user limit
- Advanced alerts (SMS, Phone-calls)
- Look further In history (more log DB)
- Integration into 3rd party system (Open API)
- Reports in PDF

Portal providers

Global:	SensDesk.com	HW_group_s.r.o.	Netherlands:	SensDesk.nl	MCS N.V.
Austria:	SensDesk.at	BellEquip GmbH	Luxembourg:	SensDesk.nl	MCS N.V.
Belgium:	SensDesk.nl	MCS N.V.	Romania:	SensDesk.ro	Sincro Systems s.r.l.
Czech Republic:	HWportal.cz	HW_server_s.r.o.	Switzerland:	SensDesk.ch	INSERTO AG
France:	SensDesk.fr	QL3D	Latvia:	SensDesk.lv	Baltic Project Group SIA



SensDesk.com portal features

Graphs of values



SMS & Voice call alerts

Actions on sensor Temperature local

rehak Adopt device PREMIUM

Dashboards Devices Sensors Locations Device groups Multigraphs Settings

Home » Sensors » Temperature local

Actions on sensor *Temperature local*

View Edit Actions EventLog Delete

Name Sort by Type ▲ Name ▲ Clear filter

Action = Temp_VoiceCall

Temperature local

SMS

Enable Voice call in SMS settings

Add action

1 Target

+ Manage Action

Multigraph of several values



Other features & PDF reports

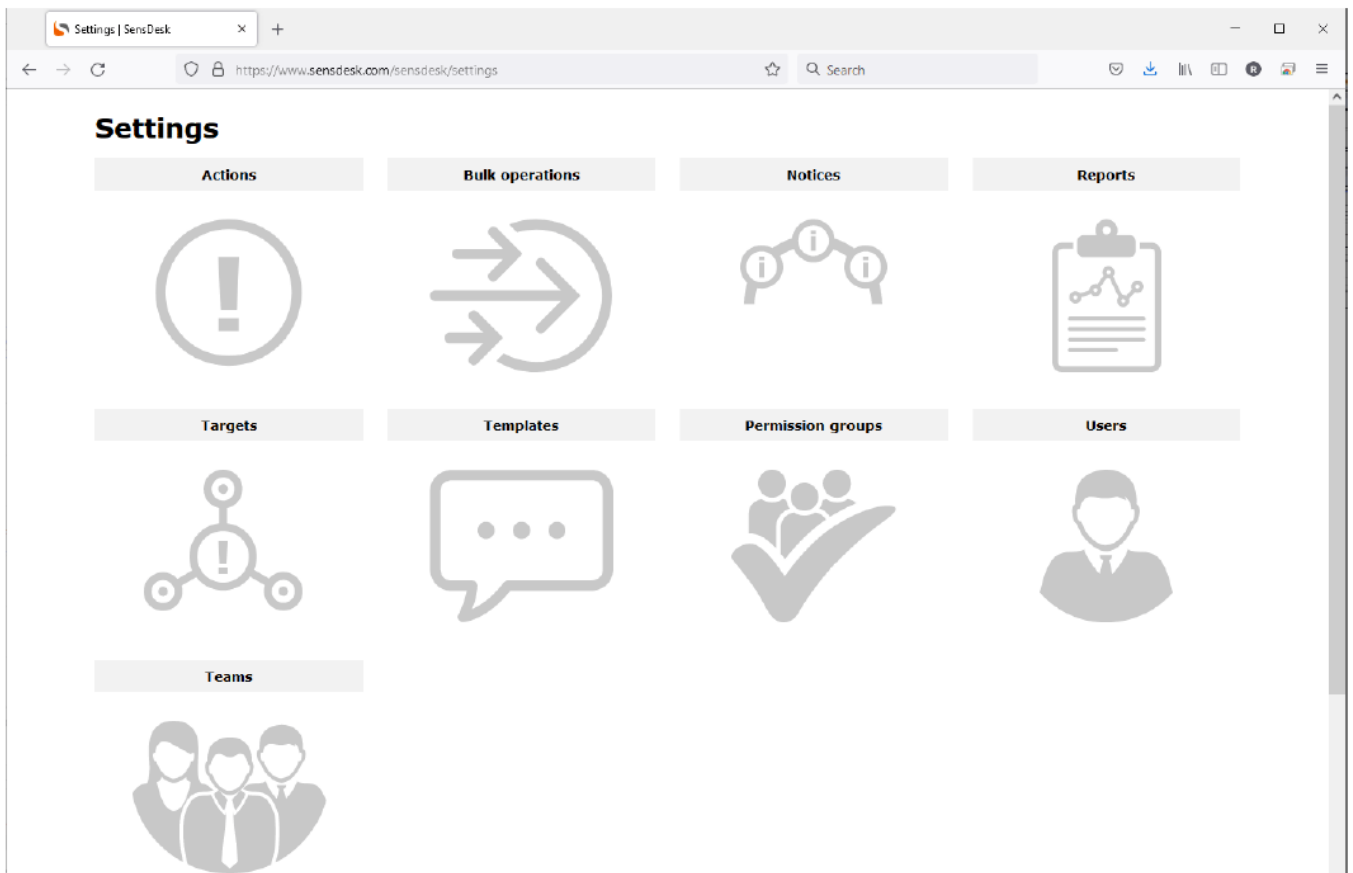

Open API (SNMP & XML)

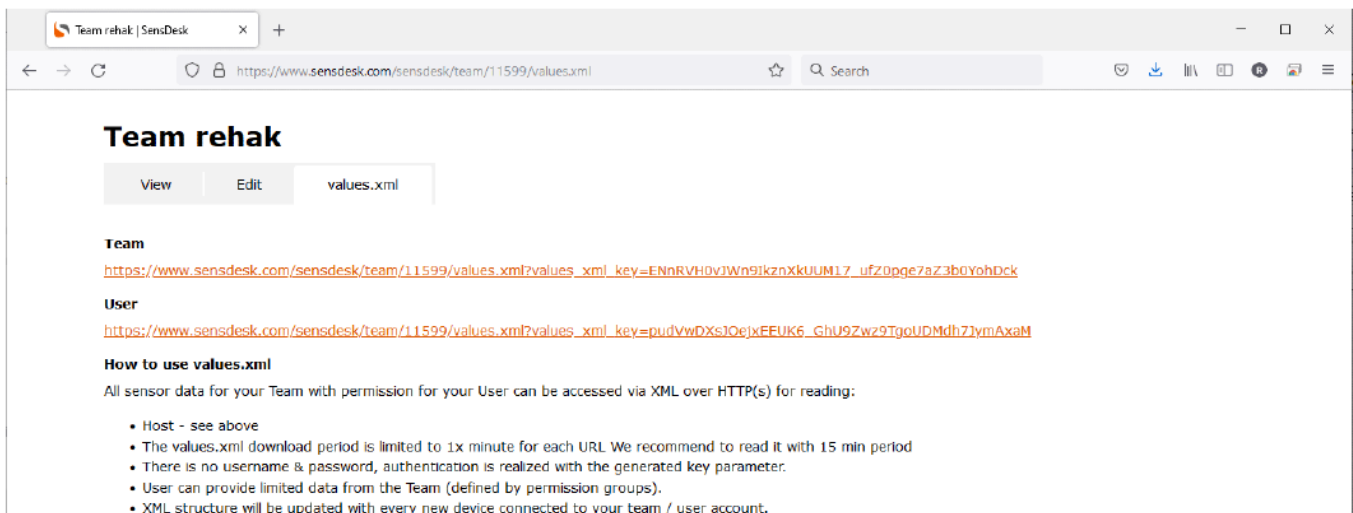

NB-Devices models and their specific features

NB-2x1Wire

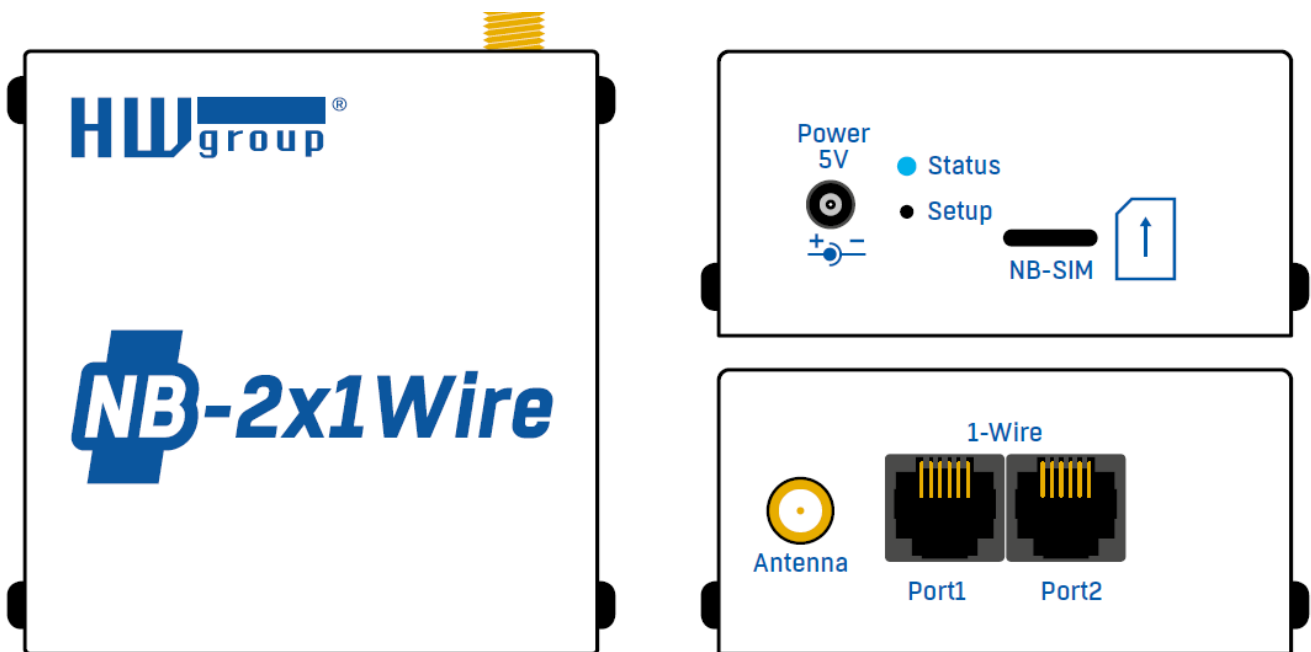

Measurement hub for connecting thermo-meters, humidity sensors or other sensors via the 1-Wire bus. Allows connecting two 1-Wire or 1-Wire UNI sensors (one per port) to measure up to 4 quantities simultaneously.

Sensors are detected whenever power is connected to the device or the Setup button is pressed. The device can be powered from an external 5V adapter, from its internal battery, or using a combination of these. With a single connected Temp-1Wire IP67 temperature sensor and the default sensor reading and data upload periods, the battery lasts up to 3 years. When using 1-Wire UNI sensors, either the sensors or the NB-2x1Wire device should be powered from an external adapter because such sensors significantly reduce the battery life.

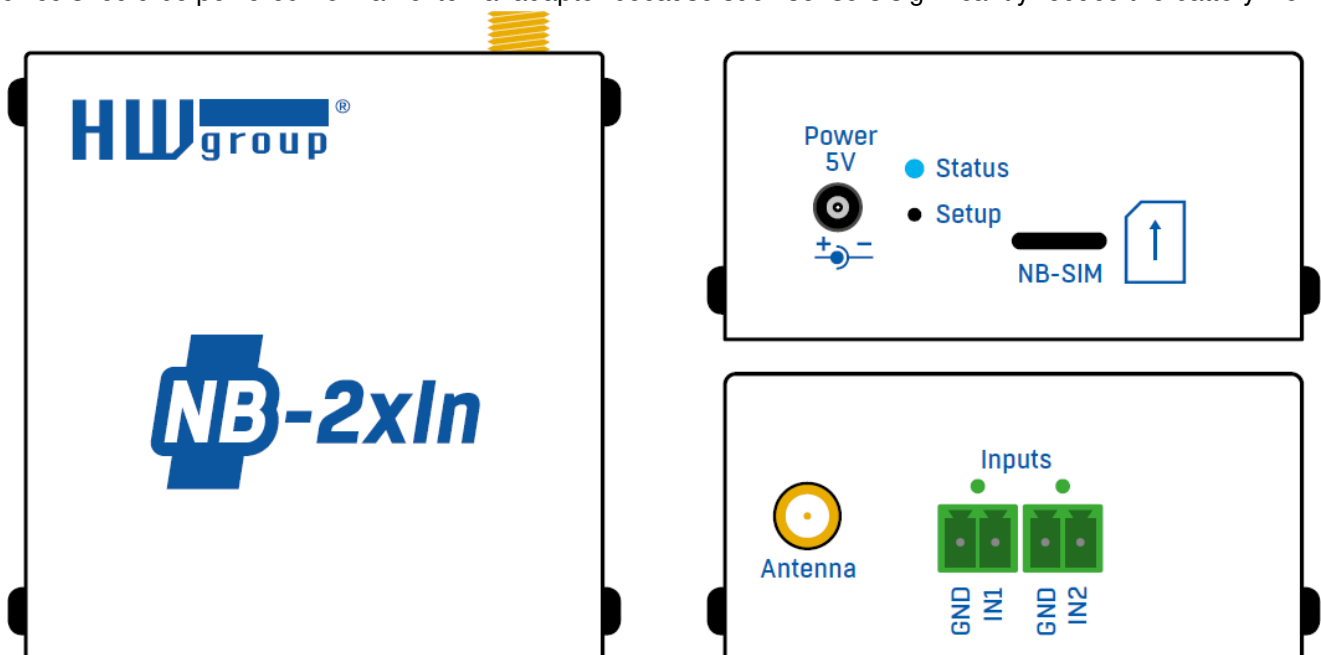

A device for connecting a door or window contact, a PIR motion detector or a smoke or gas detector with a dry contact output. Allows connecting 2 independent detectors. Inputs feature pulse counters for connecting energy meters with an S0 output. **Due to high energy requirements of S0 outputs, external power is required for reliable pulse counting.** Otherwise, reliable operation cannot be guaranteed.

The input mode (Alarms or Counters) can be changed in the digital input configuration at the SensDesk portal using the "Alarm level" parameter.

If the "Not Defined" option is selected, the input is in pulse counting mode and its state is only uploaded in the regular data upload period. Only changes longer than 20 ms are detected.

When Alarm level = 1 or Alarm level = 0, the input is in the Alarm mode. The input state is uploaded in the regular data upload period as well as whenever there is a change. To comply with the transmission limit, the device will send no more than 3 alarms per 10 minutes. Frequent state changes can have a significant impact on battery life. **For battery operation, cables should be as short as possible to avoid false pulses. For operation with an external power adapter, the cable should be at most 50 m long.**

The default mode is the counter mode (i.e. Alarm level = Not defined).

When an input is activated (contact closed) and the device is powered from an external adapter, the respective green LED lights up. The LEDs are inactive on battery power.

NB-WLD

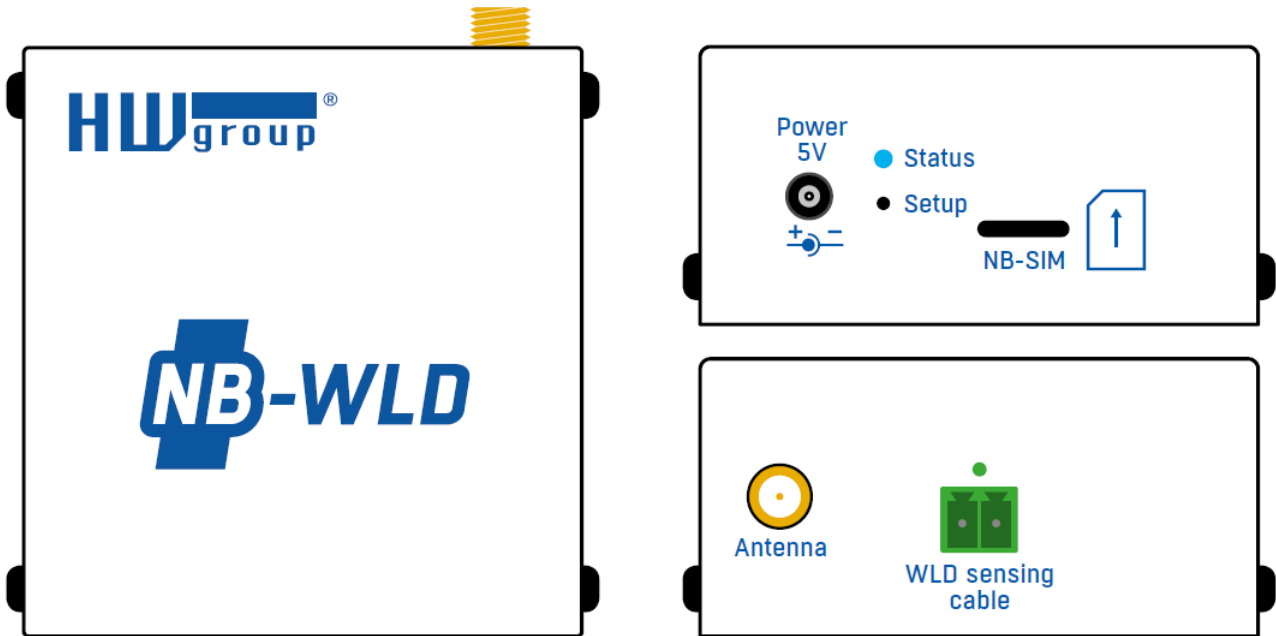

Water leak detector with a moisture-sensing cable. Allows connecting 1 sensing cable of up to 65m length, or extend it by up to 20 m.

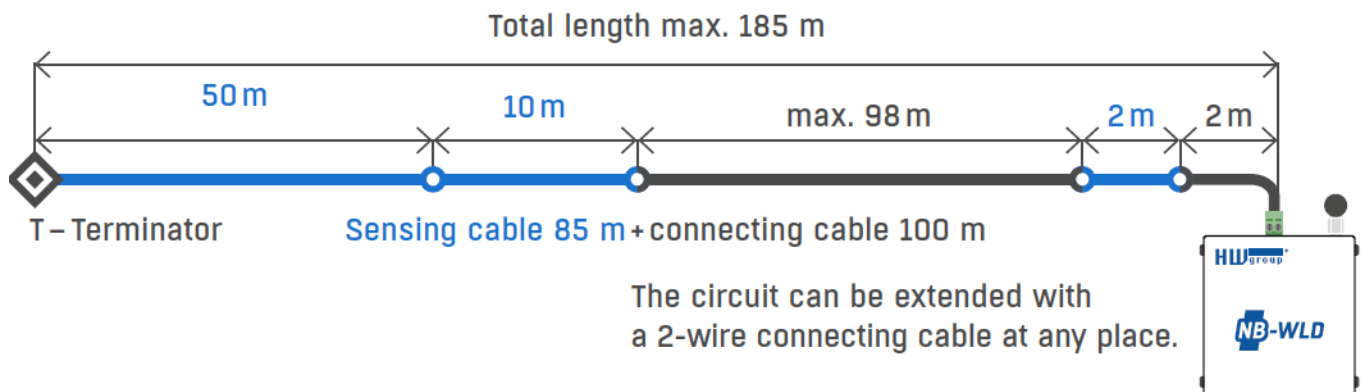

The flood detection is performed every 5 minutes and the estimated battery life are 4 years.

If the cable is flooded or disconnected and the device is powered from an external adapter, the red LED lights up. The LED is inactive on battery power.

NB-2xOUT

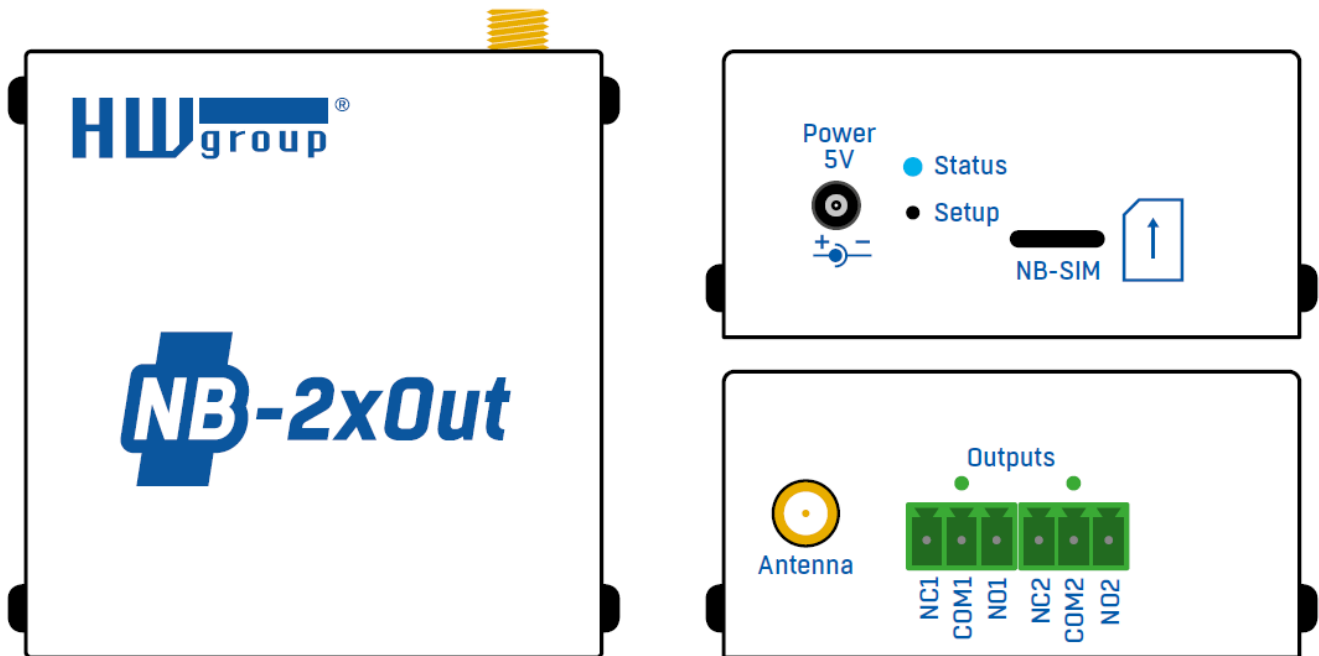

A module with 2 relay outputs controlled from the SensDesk portal over the NB-IoT network. To reduce consumption, the device features two latching relays. For increased reliability, the relays are energized repeatedly every 10 minutes. The device is not suitable for mobile applications. On battery power only, the estimated battery life are 2 years.

When an output is closed and the device is powered from an external adapter, the respective yellow LED lights up. The LEDs are inactive on battery power.

Technical specifications

External sensors (NB-1Wire only)	
Port / connector	Port1, Port2 / RJ11 (1-Wire, 1-Wire UNI)
What can be connected	2 external sensors. One combined temperature + humidity sensor can be also connected
Sensor types	Only sensors by HW group s. r. o.
Sensors / distance	4 values, max. 2 probes per port (max. 60 m total length per port)
Alarm LED	Alarm Port1 – Alarm SENS – lights up if the sensor is in alarm

WLD cable (NB-WLD only)

Type	Moisture sensing cable
Connector	Terminal block
Sensor states	0 = OK, 1 = Flooded, 2 = Cable disconnected
Sensing cable length	Up to 65 m
Cable extension	May be extended by at most 20 m, AWG 24
LED	1× red – activated or cable disconnected – on external power only

DI – Dry Contact Inputs (NB-2xIN only)

Port / connector	I1, I2 / terminal block ø 2 mm
Type	Digital Input (supports NO/NC Dry contact)
Sensitivity	1 (On) = 0 – 500 W
Max. distance	Up to 10 m
Counter sensitivity	20 ms
LED	2× green – input contact closed – on external power only
Pulse counter	External power required for reliable pulse counting – S0 = min 5 V / 2 – 10 mA.

Relay outputs (NB-2xOUT only)

Type	Latching (bipolar) relay
Connector	Terminal block
Rating	Max. 500 mA at 125 V AC, 1 A at 30 V DC
LED	2× green – output contact closed – on external power only

NarrowBand	
Supported bands	B1 / B2 / B3 / B4 / B5 / B8 / B12 / B13 / B17 / B18 / B19 / B20 / B25 / B26* / B28 / B66
Certifications	<p>Carrier:</p> <p>Vodafone (Global)</p> <p>Deutsche Telekom / Telefónica* (Europe)</p> <p>AT&T / T-Mobile / Verizon* / Sprint* (North America) LGU+* (South Korea)</p> <p>SoftBank / NTT DOCOMO* (Japan) Telstra* (Australia)</p> <p>Regulatory:</p> <p>GCF (Global) CE (Europe)</p> <p>FCC / PTCRB (North America) IC (Canada)</p> <p>KC (South Korea) NCC (Taiwan)</p> <p>JATE / TELEC (Japan)</p> <p>RCM (Australia) NBTC (Thailand) IMDA (Singapore) Others:</p> <p>RoHS</p> <p>ATEX (Europe)</p>
Output power	23 dBm +- 2 dB
Sensitivity	129 dBm
Antenna	External, SMA
Supported protocols	IP: UDP/IP (COAP)

Power	
Supply voltage	5 V DC / 120 mA
Connector	Jack Ø 3.5 x 1.35 / 10 mm
Battery	Alkaline 3V model CR123A

Common LEDs	
Status	Blue – communicating in the NB-IoT network (on), connecting to the network (flashing), reading sensors (brief flash)

Button	
Setup	Short press – sensor detection, immediate upload of values Pressed for longer than 10 s – reset to factory defaults

Miscellaneous	
Operating temperature	-10 to +60 °C (for the device – sensors may support different operating ranges)
Dimensions / weight	67 × 78 × 33 mm / 250 g
Electromagnetic radiation	CE / FCC Part 15, Class B
EMC	EN 55022, EN 55024, EN 61000

Mechanical dimensions

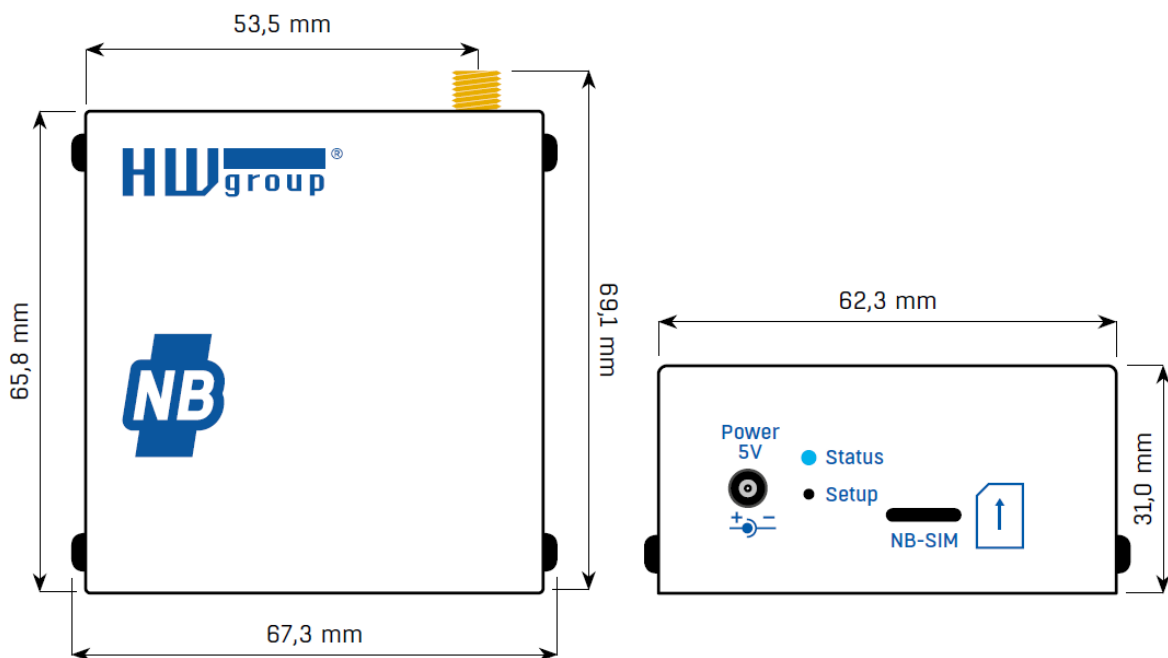

More monitoring devices by HW group

Poseidon2 4002

Designed for demanding monitoring applications, such as in data centers and industrial settings.



Poseidon2 3468

Remote monitoring of temperature, humidity and other sensors. Industrial version.

Poseidon2 3266/3268

Basic unit for monitoring temperature, humidity, and other sensors over the network.



Ares 10/12

Remote environment monitoring at any place with GSM coverage.

SD family

Simple devices for the monitoring of temperature, humidity, voltage, current, and other parameters.



WLD2

Quad water leak detector with WiFi and Ethernet.

HW group s. r. o. Rumunská 26/122 Prague, 120 00 Czech Republic

Phone: +420 222 511 918 Fax: +420 222 513 833

www.HW-group.com

Documents / Resources



[HW-group NB-2X1WIRE Temperature and Humidity Monitoring Device](#) [pdf] User Manual
NB-2X1WIRE, Temperature and Humidity Monitoring Device

References

- [User account | HWg-cloud](#)
- [User account | SensDesk](#)
- [HW HW-group.com](#)
- [User account | HWg-cloud](#)
- [Uživatelský účet | HW Portal](#)
- [User account | SensDesk](#)