



# HARVEST TEC 201RB H2O Sensor Owner's Manual

[Home](#) » [HARVEST TEC](#) » HARVEST TEC 201RB H2O Sensor Owner's Manual 

## Contents

- [1 HARVEST TEC 201RB H2O Sensor](#)
- [2 Product Information](#)
- [3 Product Usage Instructions](#)
- [4 Introduction](#)
- [5 Tools Needed](#)
- [6 Moisture Disc Installation Reference Chart](#)
- [7 Installation of Applicator](#)
- [8 End of Bale Sensor Installation](#)
- [9 Control Box Installation](#)
- [10 Dye Marker Installation](#)
- [11 Wiring Diagram](#)
- [12 Downloading H2O App](#)
- [13 Screen Definitions](#)
- [14 Operation](#)
- [15 Pin Outs](#)
- [16 Parts Breakdowns](#)
- [17 Warranty and Liability Agreement](#)
- [18 Documents / Resources](#)
  - [18.1 References](#)





## Product Information

### Specifications:

- **Model:** 201RB, 201RBC & 200DM
- **Product Type:** Round Baler Precision Moisture Sensing Kit
- **Moisture Reading Range:** 5-60%

## Product Usage Instructions

### Requirements:

The Harvest Tec H2O Moisture Sensing Kit requires the use of the following tools for installation:

- SAE wrench set
- Standard screwdriver
- Side cutter
- Hammer
- Measuring tape
- SAE socket set
- Drill bit set
- Center punch

### Installation Instructions:

#### Moisture Disc Installation Reference Chart:

Refer to the chart to identify the correct moisture disc installation instructions for your specific baler model.

#### Installation of Moisture Sensor Pads and Discs – Option A:

1. If your baler is equipped with bale shaping pads, remove the disc and use the existing hole (may need to be drilled larger).
2. If your baler is not equipped with bale shaping pads, drill a hole in the chamber directly behind and above the starting roll.
3. The mounting hole should be 3/4" (19mm) in diameter. Use a plastic pad as a template, placing it 1" (25mm) up from the starting roll and 2" (51mm) from the back of the bale chamber.

## Frequently Asked Questions (FAQ)

- **Q: What devices are supported by the Harvest Tec H2O Moisture Sensing Kit app?**

A: The app supports operation on both Apple and Android devices with the current operating system and one previous version.

- **Q: What is the recommended power cable for proper communication with the Harvest Tec H2O module?**

A: It is recommended to use the original phone/tablet power cable as many lower-cost cables may not meet requirements for proper charging and communication.

## Introduction

Congratulations and thank you for purchasing a Harvest Tec H2O Moisture Sensing Kit Model 201RB system. Please read this manual carefully to ensure the correct steps are taken to attach the system to the baler. This system is designed to read moisture at levels of 5-60%.

## Requirements

- The app will support operation of the current operating system and one previous version for both Apple and Android devices.
- It is recommended for proper communication that the original phone/tablet power cable is used. Many lower-cost power cables do not meet the requirements to properly charge and communicate to the Harvest Tec H2O module.

## Tools Needed

- SAE wrench set
- Standard screw driver
- Side cutter
- Hammer
- Measuring tape
- SAE socket set
- Drill bit set
- Center punch

## Moisture Disc Installation Reference Chart

Use this chart to identify the correct moisture disc installation instructions for each baler model.

<b>Baler Make</b>	<b>Baler Model</b>	<b>Install Option</b>
<b>AGCO</b>	5134, 5415, 550	<b>B</b>
	5446, 5446 Silage, 5456, 5545, 5545 Silage, 5546, 5546 Silage, 5556, 5556 Silage, 2745, 2746, 2746A, 2756A, 2766	<b>E</b>
	2846, 2846A, 2856, 2856A, 2946, 2946A, 2956, 2956A	<b>F</b>
<b>CasellH</b>	8400 Series, RB444, RBX 442, 443, 451, 461, 561	<b>B</b>
	RB 454,464, RBX 452, 453, 462, 463	<b>B</b>
	RB 554, 564, RBX 552, 553, 562, 563, 564	<b>B</b>
	RB 455, 465, 560, 565	<b>A</b>
	RB455A Utility Baler	<b>A</b>
<b>Challenger</b>	RB 34, 44, 45, 452	<b>B</b>
	RB 46, 56	<b>E</b>
	RB 453, 453A, 463, 463A, 563, 563A, RB 56C, RB56CA	<b>F</b>
<b>Claas</b>	Rollant Fixed Chamber, Variant Balers	<b>B</b>
<b>Hesston</b>	500 Series: 530, 540, 545, 550, 555S, 555T, 560, 565A, 565T, 700 Series – 730, 740, 745, 5400, 5500, 5600, 5800, Series Fixed Chamber, 814 Fixed Chamber	<b>B</b>
	800 Series – 845, 846A, 855, 856, 900 Series – 946, 955, 956	<b>E</b>
<b>John Deere</b>	430, 510, 530	<b>B</b>
	435, 455, 465, 535, 545, 565, 446, 456, 466, 546, 566, 447, 457, 467, 547, 557, 567	<b>C</b>
	448, 458, 468, 558, 568, 449, 459, 459E, 469, 559, 569, 440, 450, 460, 550, 560	<b>C</b>
	440, 450, 460, 550, 560 w/HC2	<b>C</b>
	960, 990	<b>G</b>
	582 Silage Special, 854	<b>D</b>
	C451R, V451R, V461R	<b>G</b>
<b>Krone</b>	Round Pack Fixed Chamber, 1250, 1250 Multi-Cut, 1550, 1550 Multi-Cut, KR 125, F 130, Vario Pack, 1510, 1810, Comprima Series	<b>B</b>
<b>Kubota</b>	BV4160, BV4180, BV4580, BV5160	<b>A</b>
<b>Kuhn</b>	VB 2160, 2190, VB 2255, 2260, 2265, 2285, 2295	<b>B</b>
<b>McHale</b>	V660, F540, F550, F560, Fusion Balers	<b>B</b>
<b>Massey Fergu</b>	1734, 1745, 1746, 1756	<b>B</b>
	2745, 2746, 2746A, 2756A, 2766	<b>E</b>

<b>son</b>	2846, 2846A, 2856, 2856A, 2946, 2946A, 2956, 2956A	<b>F</b>
	RB4100V	<b>B</b>
<b>New Holland</b>	544, 548, 564, 630, 634, 638	<b>B</b>
	640, 644, 648, 650, 658, 660, 664, 668, 678, 688	<b>B</b>
	BR 7060, 7070	<b>B</b>
	BR 7080, 7090	<b>B</b>
	BR 730, 730A, 7050	<b>B</b>
	BR 740, 740A, 750, 750A	<b>B</b>
	BR 770, 770A, 780, 780A	<b>B</b>
	Roll Belt 450, 460, 550, 560, 565	<b>A</b>
	BR450 Utility Baler	<b>A</b>
	RF 440, 450 Fixed Chamber	<b>C</b>
<b>New Idea</b>	4800 Series Fixed, 6343, 6344, 6345, 6364, 6365, 6454, 6464, 6465	<b>B</b>
<b>Vermeer</b>	404, 504 Series 1 Pro	<b>B</b>
	404, 504 Series 2 Pro	<b>B</b>
	604 Series 3 Pro	<b>B</b>
	504, 505 J, K, M, N, Series, Rebel Series, XL Series	<b>B</b>
	604M, 605M, 604N, 605N, 504R	<b>B</b>
<b>Vicon</b>	RF Fixed Chamber 119, 2121, 2125, 2235, RV 1601, 1901, 2160, 2190	<b>B</b>
<b>Welger</b>	RP Fixed Chamber 202, 220, 235, 245, 415, 420, 445, 520, 535	<b>B</b>

## Installation of Applicator

### Option A – Installation of Moisture Sensor Pads and Discs

Refer to Moisture Disc Installation Reference Chart to locate correct install option.

1. Open the rear tail gate of the baler and lock it in the up position. Refer to the baler manual to lock the door open.
2. Remove bale-shaping discs on each side of the chamber.
3. Place the plastic isolator (006-4641FX) in the same spot that the shaping disc had been. There should be a hole in the baler that matches up with the hole in the plastic isolator, this hole will need to be drilled out to 3/4" (19mm). If there is not a hole, use the isolator as a template and mark the hole. Center punch the hole and drill it to 3/4" (19mm). Note: Before drilling make sure you are not drilling into sensitive equipment on the outside of the baler). Repeat for the other side of the baler.
4. Insert plastic bushing (006-4641G) from the outside of the baler. Make sure it is flush with the outside of the baler frame. Go to the inside of the baler and mark the amount that protrudes into the chamber. Remove and cut off excess material. Repeat for the other side.
5. Using the 4" carriage bolt slide the parts on in the following order: metal disc (001-4641HX), plastic isolator

(006-4641FX), and shortened plastic bushing (006-4641G).

6. Insert disc assembly into 3/4" (19mm) hole from inside of bale chamber. Secure to the outside of the baler by attaching to the protruding carriage bolt in the following order: small isolator (006-4641I), 1/2" D shaped washer, 1/2" lock washer, 1/2" nut. Tighten down and repeat for the other side. Make sure no part of the bolt or hardware makes contact with the frame of the baler-no metal to metal. Trim 006-4641I to fit.
7. Route moisture harness (006-2470RB) from the drawbar down to the carriage bolt on each side. Make sure it does not come in contact with any moving parts. Secure with cable ties.
8. Attach moisture cable to moisture carriage bolt by placing items in the following order: 1/2" D-shaped washer, Ring terminal of moisture harness (006-2470RB), second 1/2" D washer, 1/2" lock washer, 1/2" nut. Tighten down and repeat for the other side. Make sure none of the hardware contacts the frame of the baler.

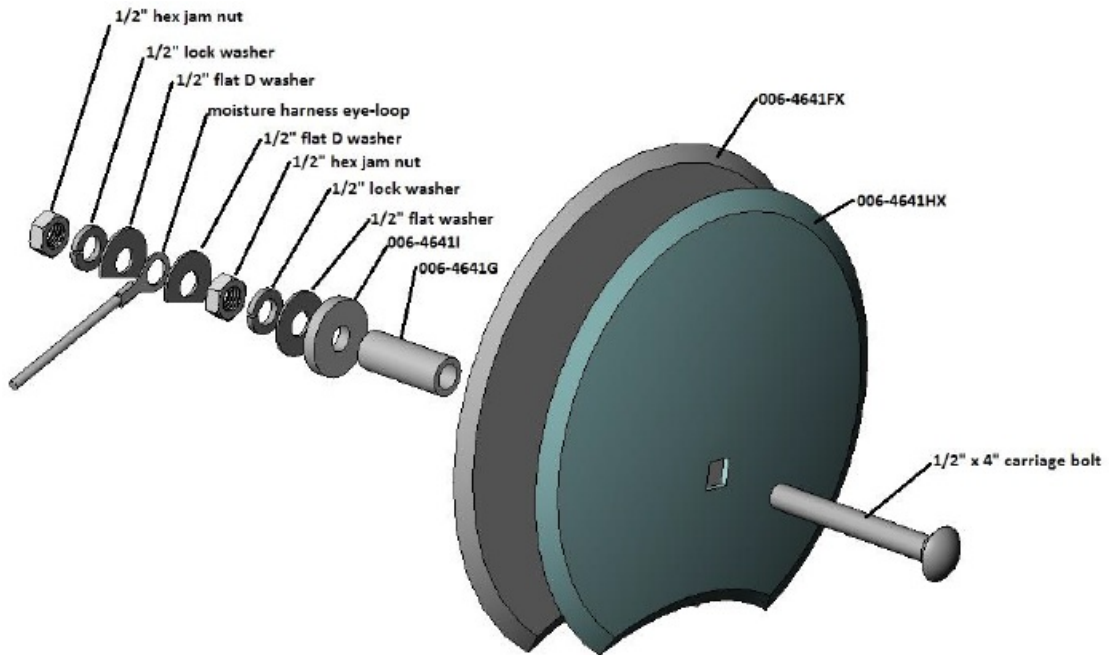

5

### Option B – Installation of Moisture Sensor Pads and Discs

\*Refer to Moisture Disc Installation Reference Chart to locate correct install option



Figure 1

1. If your baler is equipped with bale shaping pads, remove the disc and use the existing hole (may need to be drilled larger, 3/4" (19mm) to install new moisture sensing discs.

- If your baler is not equipped with bale shaping pads you will need to drill a hole in the chamber directly behind and above the starting roll (Figure 1).
- The mounting hole will be 3/4" (19mm) in diameter. Use a plastic pad (006-4641F) and place it into the baler to use as a template. The bottom edge of the pad will be placed 1" (25mm) up from starting roll and 2" (51mm) from the back of the bale chamber (Figure 1).

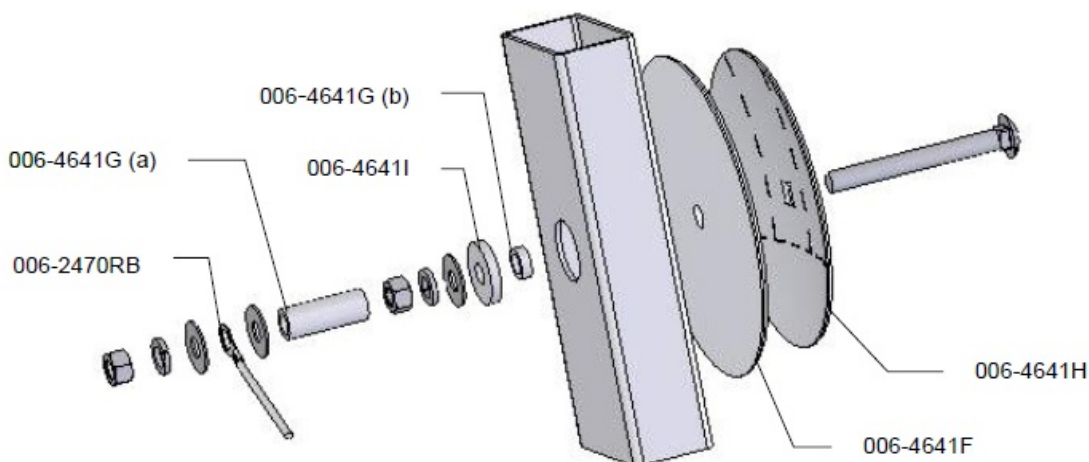

- Locate the 006-4641G (a) piece, this will need to be cut down to size. Use the already machined line in the bushing to cut off the small piece shown above 006-4641G (b). Part 006-4641I may also need to be trimmed to fit.
- Depending on the baler the bolt may need to be trimmed for proper fit.
- Tighten all of the hardware to 50 ft/lbs (68 N/m).
- Make sure that the plastic pad protects all metal surfaces of the disc from touching the baler.
- Run the moisture wire harness (006-2470RB) to each disc securing it with cable ties.

### Option C – Installation of Moisture Sensor Pads and Discs

\*Refer to the Moisture Disc Installation Reference Chart to locate the correct install option

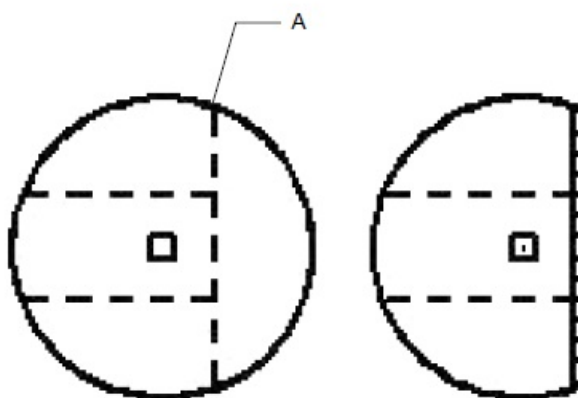

Figure 1

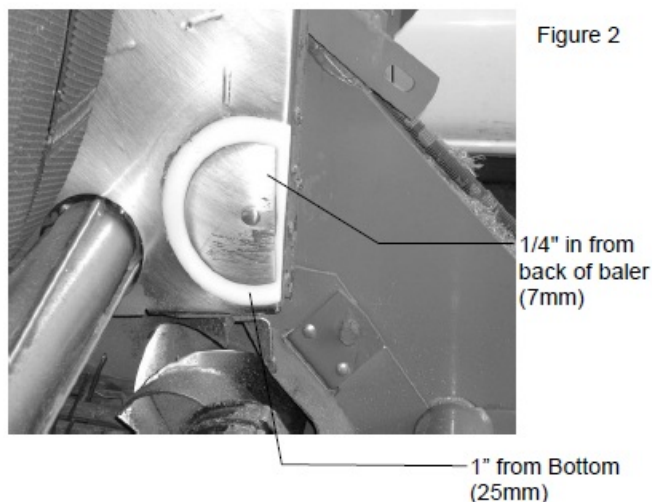
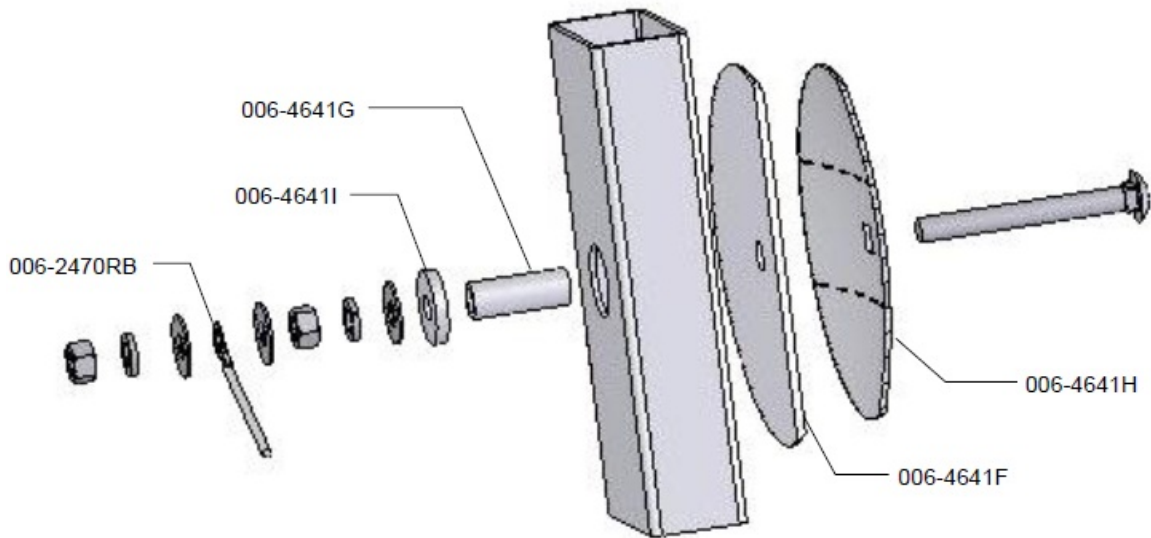

Figure 2

- Both moisture discs (006-4641H) will need to be cut along the serrated line (A) shown on Figure 1. Only cut on the line shown on Figure 1, do not cut the other line.
- The plastic pad (006-4641F) will also need to be cut 1/4" (7mm) longer than the back of the disc.
- Using the cut disc as a pattern, mark and drill a 3/4" (19mm) hole in the side of the bale chamber. The disc will need to be placed on the baler 1" (25mm) up from bottom and 1/4" (7mm) in from the back of the chamber

(Figure 2).



4. Make sure that the plastic pad is protecting all metal surfaces of the disc from touching the baler.
5. Run the moisture wire harness (006-2470RB) to each disc securing it with cable ties.
6. On some balers, the bolt may need to be trimmed for proper fit.
7. Tighten all hardware to 50 ft/lbs (68 N/m).
8. Apply silicone over nuts and washers.

#### Option D – Installation of Moisture Sensor Pads and Discs

\*Refer to the Moisture Disc Installation Reference Chart to locate the correct install option

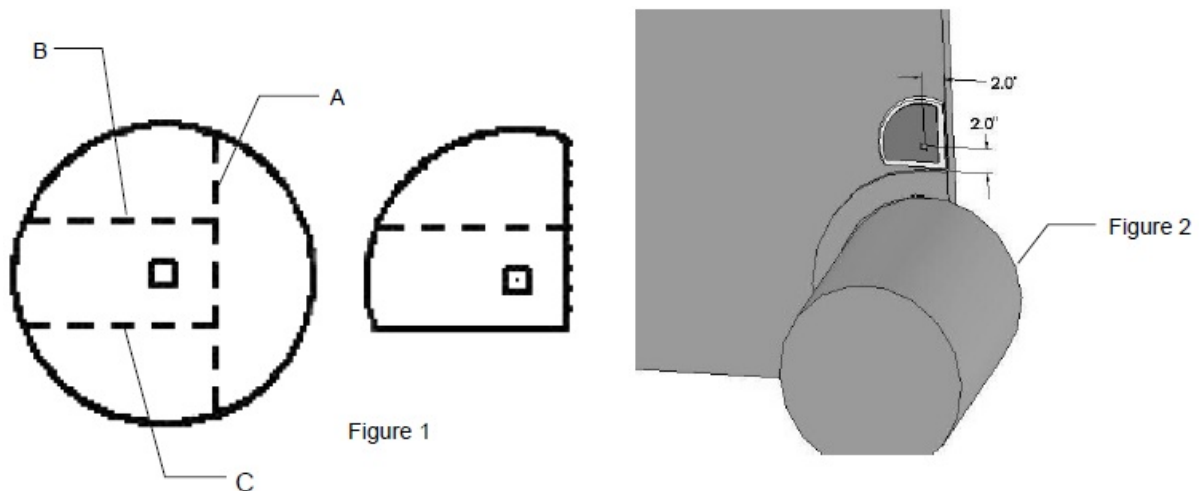

1. The moisture discs (006-4641H) will both need to be cut on line A. (Figure 1) One disc will need to be cut on line B and one disc on line C.
2. The plastic pad (006-4641F) will also need to be cut 1/4" longer than the back of the disc.
3. Bevel all sides of the cut discs to allow the smooth travel of crop over them.
4. The mounting hole will be 3/4" (19mm) in diameter. The disc will need to be placed on the baler lining up the center of the bolt with the location 2" (51mm) up from bottom and 2" in from the back of the chamber. (Figure 2)



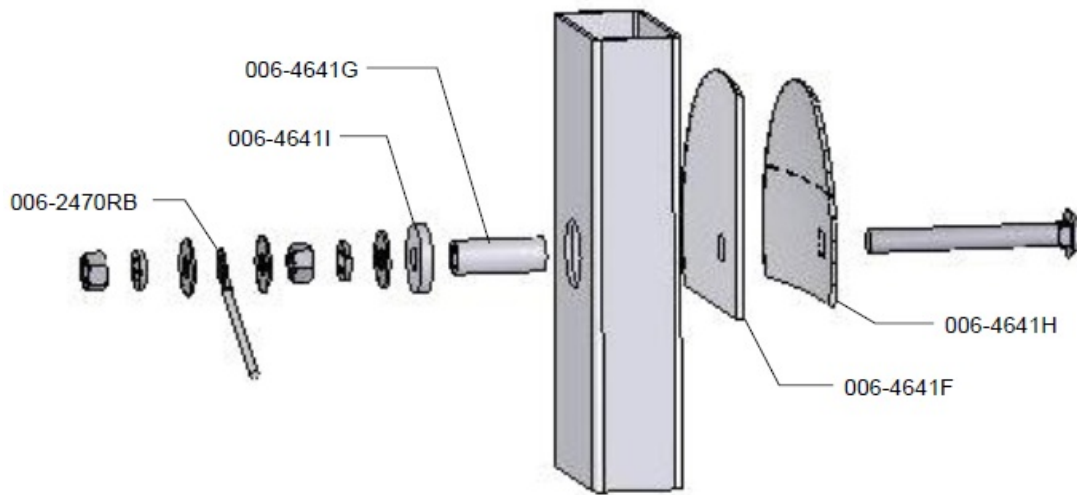

5. Make sure that the plastic pad protects all metal surfaces of the disc from touching the baler.
6. Run the moisture wire harness (006-2470RB) to each disc, securing it with cable ties.
7. On some balers, the bolt may need to be trimmed for proper fit.
8. Tighten all hardware to 50 ft/lbs (68 N/m).
9. Apply silicone over nuts and washers.

### **Option E – Installation of Moisture Sensor Pads and Discs**

\*Refer to the Moisture Disc Installation Reference Chart to locate the correct install option

1. If your baler is equipped with bale shaping pads, remove the pads and use the existing hole (which may need to be drilled larger) to install new moisture-sensing discs.
2. If your baler is not equipped with bale shaping pads you will need to drill a hole in the chamber directly behind and above the starting roll (Figure 1).
3. You will need to remove the main chain assembly to install the disk on the right side of the baler (when facing the front of the baler) Figure 2.
4. The hole size is 3/4" (19mm) diameter. Before drilling the hole make sure the hole is accessible from the opposite side of the chamber to tighten down the mounting hardware and to install a moisture harness (Figure 3).

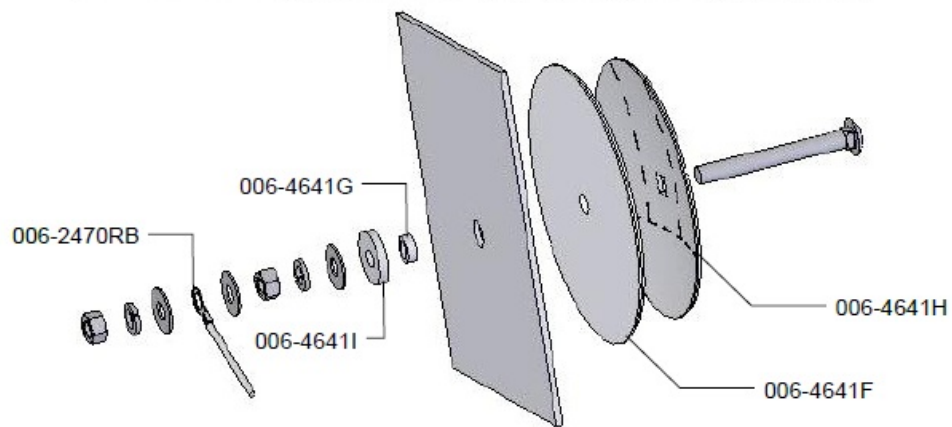
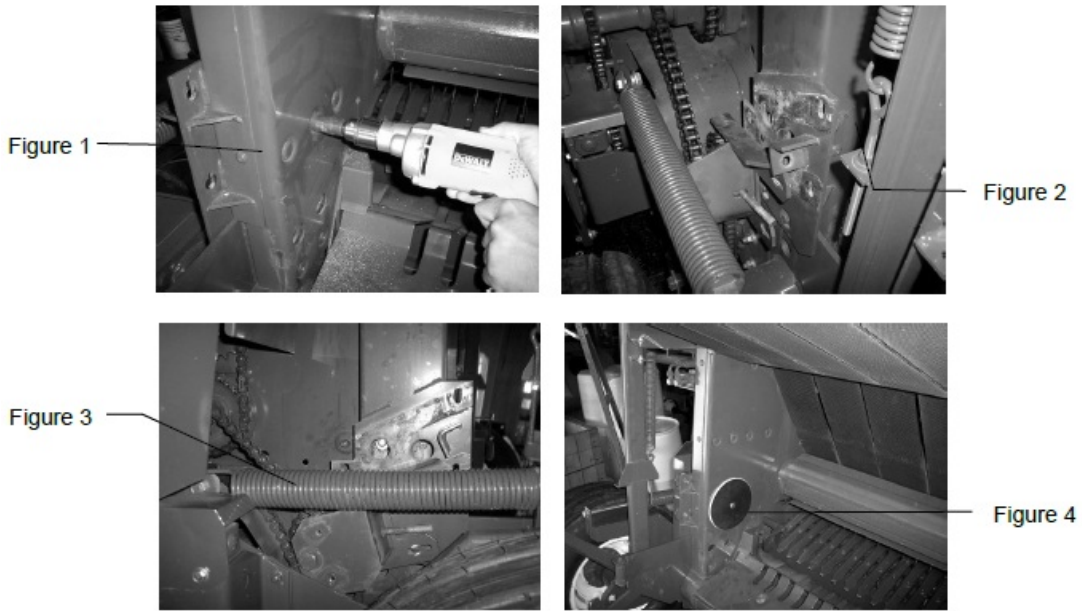

5. Locate the 006-4641G. The piece will need to be cut down to size.
6. Use the already machined line in the bushing to cut off the small piece shown above.
7. Depending on the baler the bolt may need to be trimmed for proper fit.
8. Tighten all of the hardware to 50 ft/lbs (68 N/m).
9. Make sure that the plastic pad is protecting all metal surfaces of the disc from touching the baler (Figure 4)
10. Run the moisture wire harness (006-2470RB) to each disc securing it with cable ties.
11. Apply silicone over nuts and washers.

### Option F – Installation of Moisture Sensor Pads and Discs

\*Refer to Moisture Disc Installation Reference Chart to locate the correct install option

1. Both moisture discs (006-4641H) will need to be cut along the serrated line (A) shown in Figure 1. Measure from the laser etched line (B) 1 3/4" (45mm) on both sides. Mark and cut the disc. A completed disc is shown to the right.
2. The plastic pad (006-4641F) will also need to be cut 1/4" (7mm) larger than the steel disc.
3. Bevel all sides of the cut discs to allow the smooth travel of the crop over them.

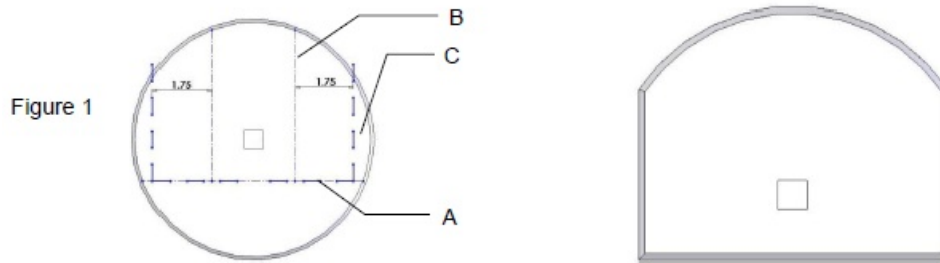

4. Mark a line 1 1/2" (38mm) up and 3 1/2" (89mm) over from point (D). Drill a 3/4" hole at the point (E). Repeat for the opposite side.

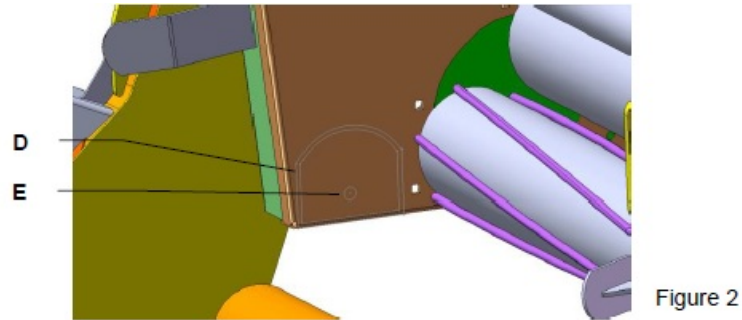

5. Locate the 006-4641G. The piece will need to be cut down to size. Use the already machined line in the bushing to cut off the small piece shown above.
6. Depending on the baler the bolt may need to be trimmed for proper fit.
7. Tighten all of the hardware to 50 ft/lbs.
8. Make sure that the plastic pad protects all metal surfaces of the disc from touching the baler.
9. Run the moisture wire harness (006-2470RB) to each disc securing it with cable ties.
10. Apply silicone over nuts and washers.

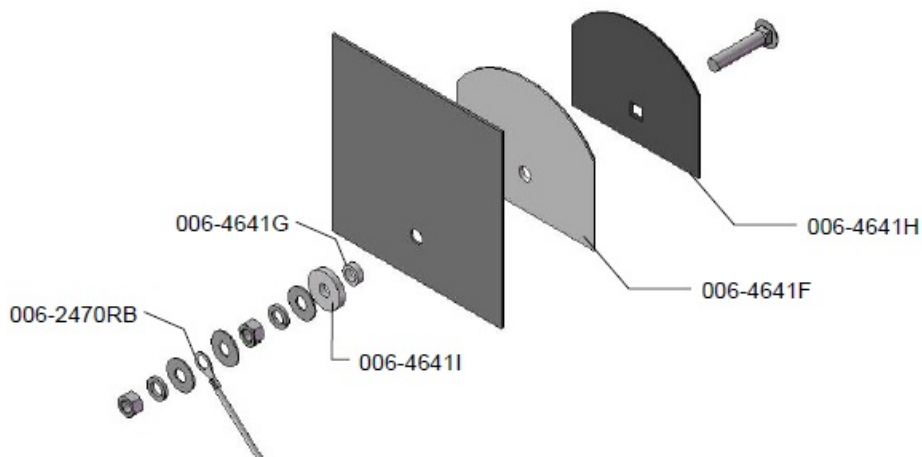

### Option G – Installation of Moisture Sensor Pads and Discs

\*Refer to Moisture Disc Installation Reference Chart to locate correct install option

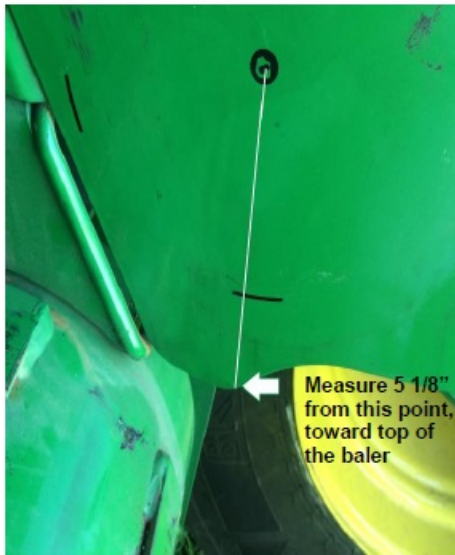
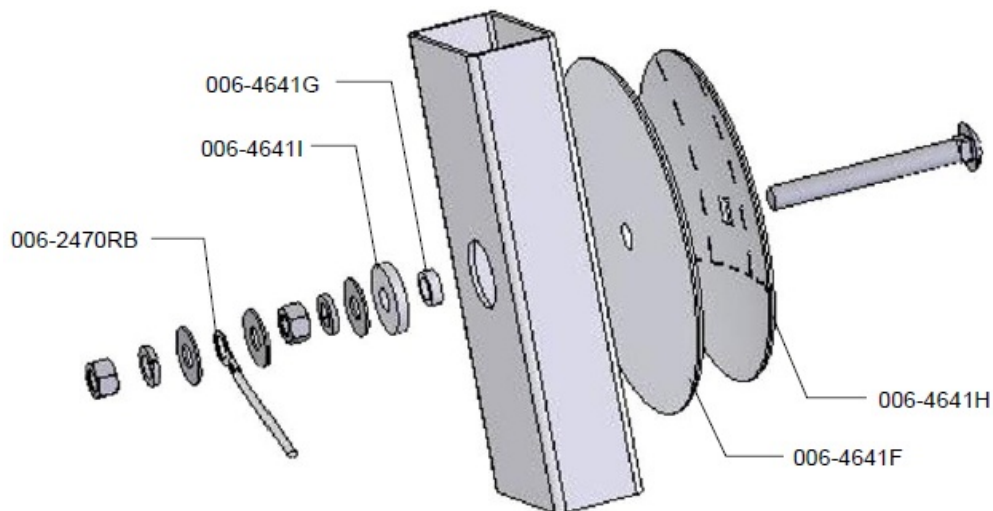

Figure 1



Figure 2

1. With the baler door open measure 5 1/8" toward the top of the baler from the point is shown in Figure 1. Drill a 3/4" (19mm) hole to mount the moisture disc as shown in Figure 2.
2. Use a plastic pad (006-4641F) and place it into the baler to use as a template. The bottom edge of the pad will be placed 2" (51mm) up from the bottom of the sheet metal on the door and starting roll and 1" (25mm) back from the sheet metal seam in Figure 2.



3. Locate parts 006-4641G, which will need to be cut down to size. Use the factory-machined line in the bushing to cut off the small piece shown above.
4. Depending on the baler the bolt may need to be trimmed for proper fit.
5. Tighten all of the hardware to 50 ft/lbs (68 N/m)
6. Make sure that the plastic pad protects all metal surfaces of the disc from touching the baler.
7. Run the moisture wire harness (006-2470RB) from the drawbar to each disc, securing it with cable ties. Be harness is clear from moving parts, chains, and potential pinch points.
8. Apply silicone over nuts and washers to seal moisture away from connections.

## End of Bale Sensor Installation

### End of Bale Sensor Installation – 200FCA (Optional)

\*This sensor is required on Fixed Chamber balers and Optional on all other Models (Kit 200FCA)

- The end of the bale sensor is used to determine when the baler door is open. With this information, the system can show the average moisture of the previous bale.
- Locate the sensor (006-7400) and the sensor bracket (001-4648RB). On the right side of the baler find a location 1"– 6" down from the hinge to mount the bracket. Check for clearance with hydraulic cylinders before mounting the bracket. The bracket should be mounted to the front side of the hinge point, with the sensor aligned over the back door.
- Mark and drill two 1/4" (7mm) holes and install the bracket using two 5/16" x1/4" self-tapping bolts.
- Install the sensor into the bracket and leave 1/4" (7mm) of clearance between the end of the sensor and the door.
- The harness will need to be routed toward the harness at the tongue of the baler. Secure with cable ties and take care to avoid pinch points. The harness extension (006-7400EXT) may need to be used.

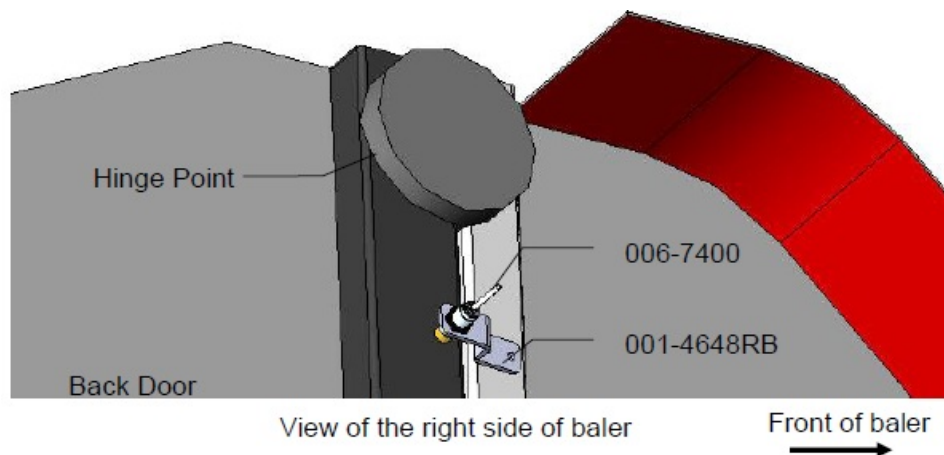

## Control Box Installation

- Locate a safe location in the cab of the tractor to place the control box (006-2473RB) in a location to connect a USB cable ending in a USB-A plug to connect to display device.
- Connect the Power Harness (006-2470P) and the Baler Power Communication Harness (006-2470RB).
- The control box (006-2473RB) is equipped with a green light to indicate both power and connection.
- Plug the tablet/phone cord into the communication port (closest to light) and indicate by:

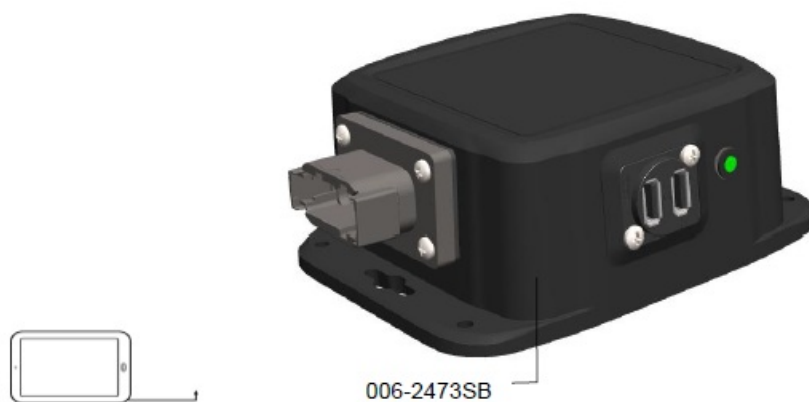

- Slow Blink – The system has power but is not connected to a phone or tablet.
- Solid Green – The device is connected.

It is recommended for proper communication that the original phone/tablet power cable is used. Many lower-cost power cables do not meet the requirements to properly charge and communicate to the Harvest Tec H2O module. The use of adapters is not supported.

## Dye Marker Installation

### Dye Marker Installation – 200DM (Optional)

Locate the dye marking kit tank and pump assembly (005-9015). Identify a suitable mounting location for the tank away from moving parts and hydraulic lines on the baler. Be sure to mount the tank within 10' of the connection on the Baler Pwr/Comm Harness (006-2470RB), wiring details are in the wiring diagram.

- **Note:** The mounting location will potentially be different for the tank on each baler model. Due to various baler designs and modifications, Harvest Tec does not offer a specific mounting location for each baler model.
- Once a mounting location has been identified, mount the tank vertically as shown (right) with the tank lid on the top using the included hardware.
- Next, locate the dye marking spray assemblies shown (below).



- Mount one tip assembly on the right side of the baler positioning the tip to allow the tip to begin spraying the bale when the door opens. Below (left) is an example of the tip assembly mounted next to the End of Bale sensor. The nozzle holder bracket can be bent or adjusted as needed to position properly.



### Round balers must use tip (004-TX-26)

Mount the second tip assembly on the left side of the baler in a similar position to allow the tip to begin spraying the bale as the door opens (right).



Mount the second tip assembly on the left side of the baler in a similar position to allow the tip to begin spraying the bale as the door opens (right).



## **Routing the Hose**

Using the supplied 1/4" hose (002-9006) connect to the pump and secure with the hose clamps (003-9002). Route the hose to each tip assembly by using the 1/4" Barbed Tee (003-T1414) to go to each side of the baler. Be sure to avoid moving parts.

## **Wiring Diagram**

1. Connect the power harness (006-2470P) to the tractor convenience outlet keyed power switch using the red wire with fuse to the positive side and the black wire to the negative.
  - Any modifications to the power harness will void the warranty. Contact Harvest Tec before modifications are made.
2. The power harness (006-2470P) will be mounted on the tractor connected to the control box (006-2473RB) with the 12-pin male Deutsch connection and the opposite end down to the drawbar.
3. Connect the Baler Pwr/Comm Harness (006-2470RB) to the power harness (006-2470P).
4. Route the Pwr/Comm Harness (006-2470RB) on the baler to each moisture sensor on both sides of the bale chamber (006-4641H). If the baler is a CNH Rollbelt or Kubota round baler, sensors are pn 006-4641HX.
5. Connect the USB charging/comm cord for the phone or tablet being used, to that device and the 201 control box (006-2473RB).
6. When using a Fixed Chamber baler or Dye Marker the End of Bale Sensor kit will need to be added to the system to see when the baler door opens to eject a bale. Part number (200FCA). Connect the sensor to the End of Bale (EOB) connection on the Baler Pwr/Comm Harness (006-2470RB).
7. When using the optional Dye Marker (200DM) connect 4 pin round end of the H2O harness (006-2470C) to the Dye Marker (DM) connection on the (006-2470RB) harness. Then connect the two straight spade connections with only the white wire to the push switch (006-2850). The remaining two connections with 90-degree female spades will connect to the pump.

## **System wiring diagram**

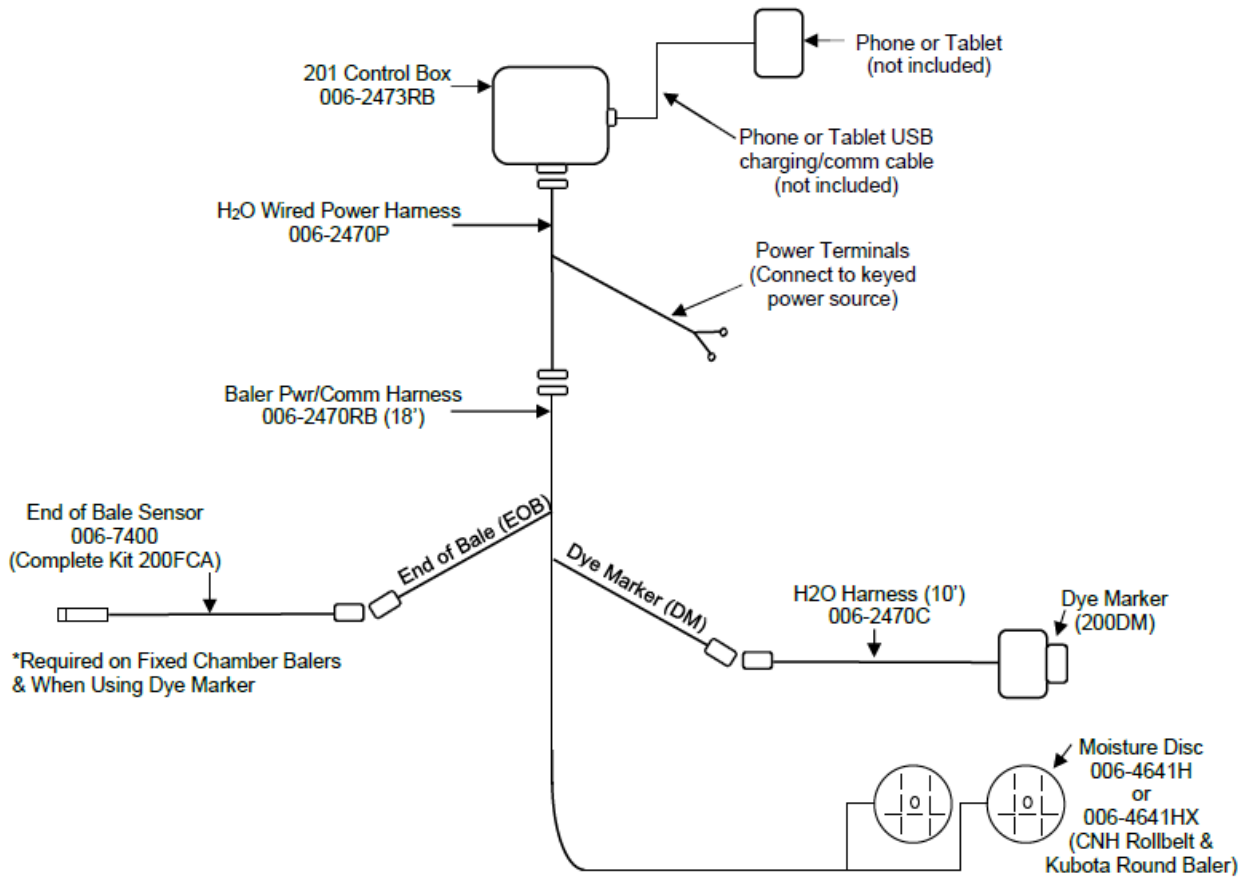

## Downloading H2O App

The H2O App is available on any Apple or Android device running with the current operating system software and one previous version. Download the app by searching for H2O Sensor. The app icon is shown right.



## Screen Definitions

### Main Screen



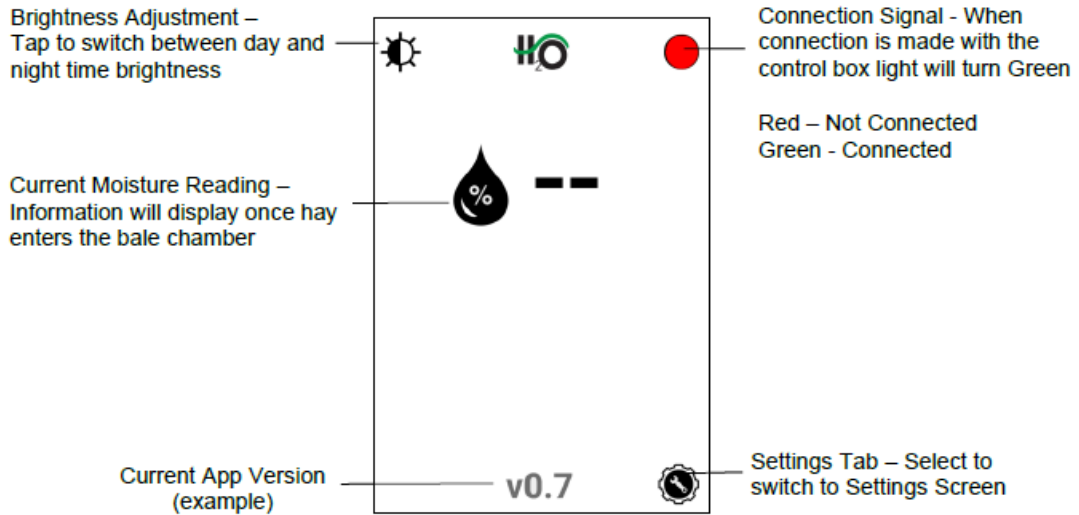

## Settings Screen

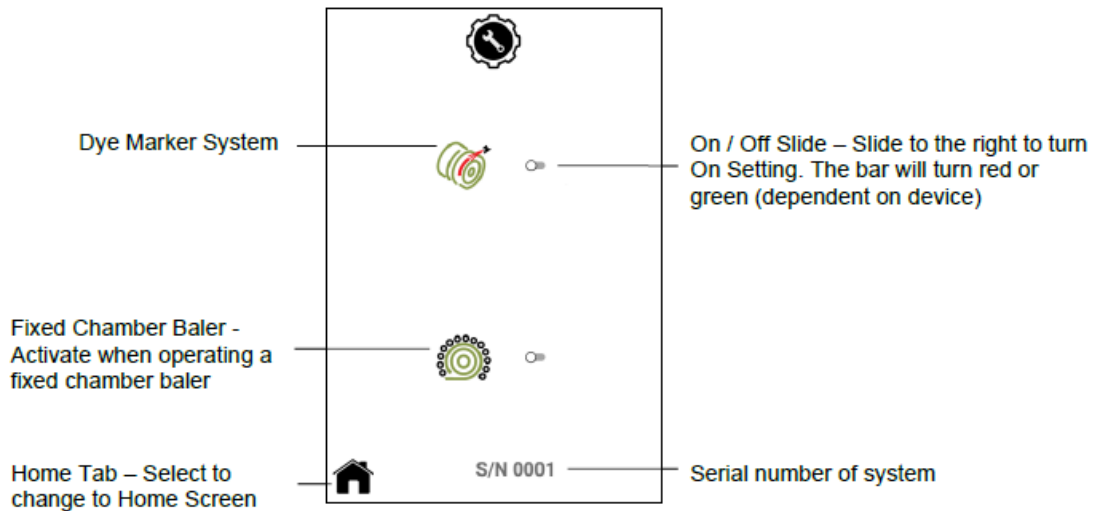

## Operation

After installation of the H2O app, turn the system on by turning the key in the tractor on. When the connection is made the green light on the control box will illuminate.

### Reading Moisture



With the hay entering bale chamber, current moisture will be displayed once the bale starts to form

### Low Moisture Reading Range

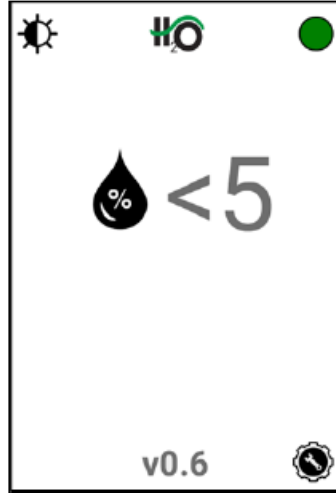

If the moisture being read is Less than 5%, then the reading will appear as shown above

### High Moisture Reading Range

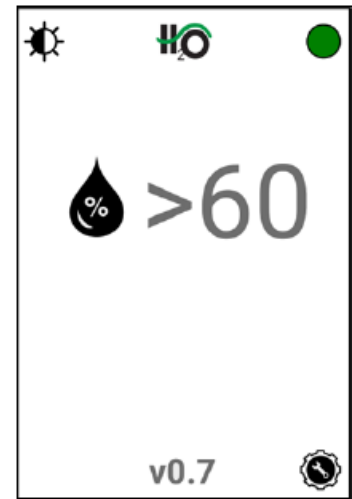

If the moisture being read is Greater than 60%, the reading will appear as shown above

### Fixed Chamber Balers Only- \*200FCA End of Bale Sensor Kit Required

- When using a fixed chamber baler, turn on the setting as shown, and enter the time to make a bale (seconds). This time is used only until a 3-bale rolling average time is calculated.
- Previous bale moisture will now display. \*Current moisture will update when 1/2 of the next bale is made and/or if using a dye sprayer.

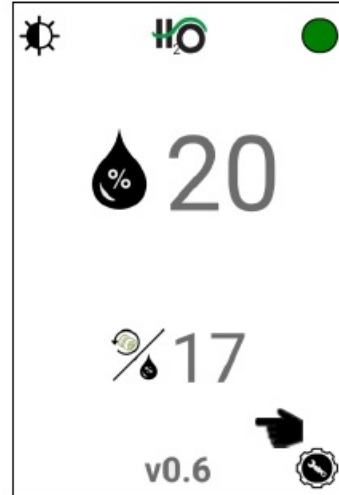
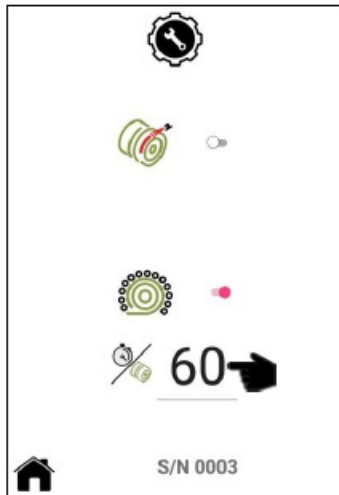

The first half of the first bale “—” will be displayed. As the system operates, the system will use the time between End of Bale signals to calculate an actual time per bale and then use a 3 bale rolling average for the time the current moisture reading is displayed.

If you would like to see the previous bale moisture when not using a Fixed Chamber baler the optional End of Bale Sensor kit will need to be installed (200FCA) and dye marker setting turned 'On'.

### Dye Marker System

- When using the dye marker turn on the setting as shown and select the desired moisture to mark a bale. \*Bales at or above this moisture level will be marked.
- Dye Marker icon will now appear on the home screen. The last bale moisture will be highlighted in red and the bale will be marked at or above the set moisture.

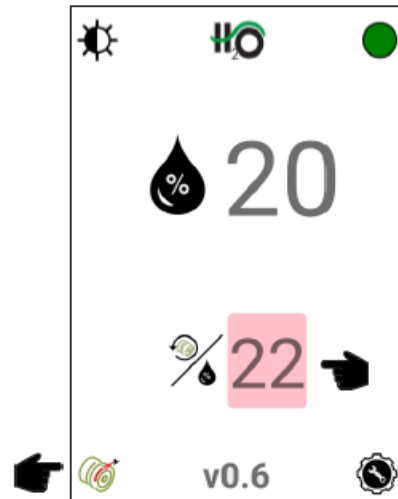

### Dye Marker Notes

- When the Dye Marker is activated by the moisture setting it will spray 3 seconds once per End of Bale (EOB) cycle. After an EOB signal, the dye marker is then reset to be able to spray again for 3 seconds once on the next bale.
- A full tank of dye is estimated to mark 50-60 bales.

### Dye Sprayer Override

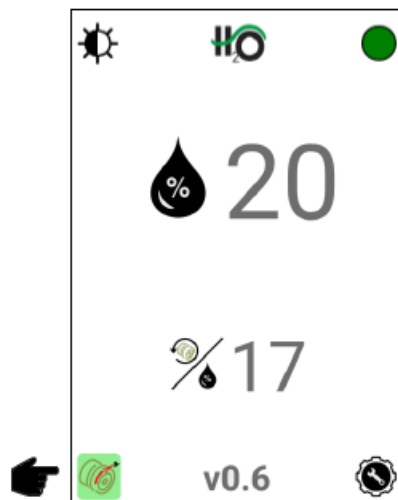

If you would like to mark a bale for any reason, press the bale icon which will cause it to turn green. \*At the next End of Bale signal the dye marker will mark the bale and the manual override will no longer be green. When the manual override is used the last bale moisture will not be highlighted in red.

### H2O Firmware Update through App

- When there is an update available for the H2O system the following information will appear and the steps listed will need to be followed.
- Once an operator downloads the app update (internet connection required) the “update available” symbol will appear along with the version number of the available update once connected to the system.
- At this point the system can run without updating if the operator chooses. The icon will simply remain on the screen.

- Once the operator decides to perform the software update, they will press the version number or upload arrow to begin.
- Internet connection is not required to perform the update to the module once the app is downloaded

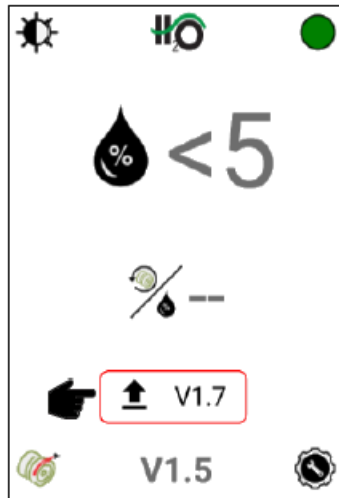

- Once the update is initiated, the system will enter update mode
  - The status light will turn red
  - A green loading symbol will begin to circulate on the screen
- A status bar with then appear to show the update progress.
  - This can take 3-5 minutes to load software
- Once the status bar load completely, the system will boot back up
  - The status light will again turn green
  - The updated version number will be shown at the bottom of the screen

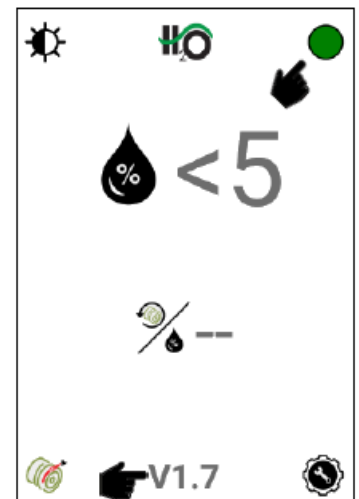
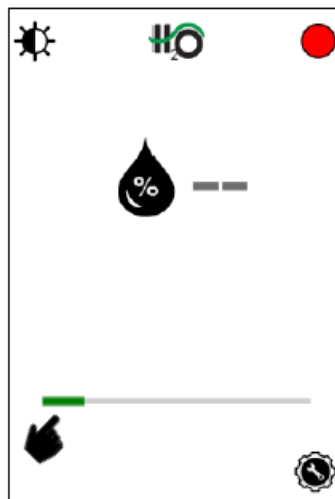

## Pin Outs

H2O Tractor Module 006-2473RB

Pin 1	Red	Module Power	Pin 2
Red/Black	EOB +		
Pin 3	Black	EOB –	
Pin 4	Grey	Left Moisture Sensor	
Pin 5	Brown	Right Moisture Sensor	
Pin 6	Purple	EOB Signal	
Pin 7	Yellow	CAN +	
Pin 8	Green	CAN –	
Pin 9	Red/White	Dye Marker 12V +	Pin 10 Black/White
	Dye Marker 12V –		Pin 11 Blue
	Marker Prime		Dye
Pin 12	Black	Ground	

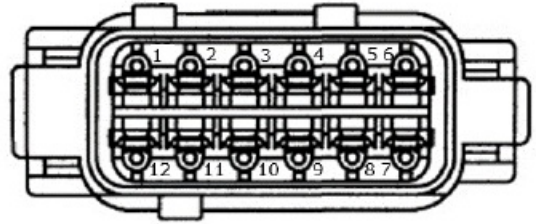

H2O Tractor Harness 006-2470P at Module Plug

Pin 1	Red	Module Power	Pin 2
Red/Black	EOB +		
Pin 3	Black	EOB –	
Pin 4	Grey	Left Moisture Sensor	
Pin 5	Brown	Right Moisture Sensor	
Pin 6	Purple	EOB Signal	
Pin 7	Yellow	Not Used	
Pin 8	Green	Not Used	
Pin 9	Red/White	Dye Marker 12V +	Pin 10 Black/White
	Dye Marker 12V –		Pin 11 Blue
	Marker Prime		Dye
Pin 12	Black	Ground	

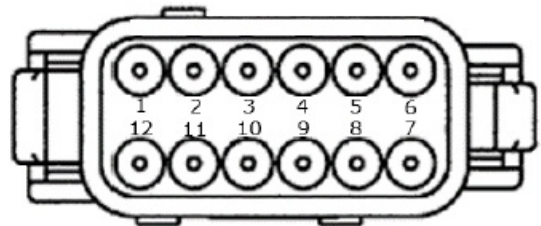

Baler Communication Harness 006-2470RB at hitch

Pin 1	Red/Black	EOB +	
Pin 2	Black	EOB –	
Pin 3	Grey	Left Moisture Sensor	
Pin 4	Brown	Right Moisture Sensor	
Pin 5	Purple	EOB Signal	
Pin 6	Red/White	Dye Marker 12V +	Pin 7 Black/White
	Dye Marker 12V –		Pin 8 Blue
	Marker Prime		Dye Ma

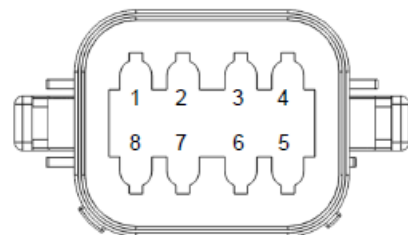

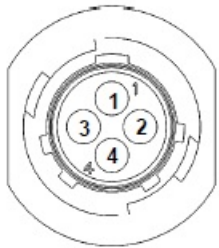
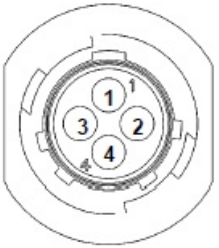
<u>End of Bale Sensor (EOB) 006-2471B</u>			
Pin 1	Brown	EOB +	
Pin 2	Blue	EOB -	
Pin 3	N/A	Not Used	
Pin 4	Black	EOB Signal	
<u>Dye Marker H2O Harness 006-2470C</u>			
Pin 1	Red	DS +	
Pin 2	Black	DS -	
Pin 3	White	DS Prime	
Pin 4	N/A	Not Used	

**Parts Breakdowns**

**Installation Option A**



<u>Ref</u>	<u>Description</u>	<u>Part #</u>	<u>Qty</u>	<u>Ref</u>	<u>Description</u>	<u>Part #</u>	<u>Qty</u>
1	Baler Pwr/Comm Harness	006-2470RB	1	5	Plastic Isolator	006-4641I	2
2	201 Series Control Box	006-2473RB	1	6	Plastic Bushing	006-4641G	2
3	Tractor Power Harness	006-2470P	1	7	Moisture Disc	006-4641HX	2
4	Plastic Pad	006-4641FX	2	NP	8' Pwr/Comm Ext. (optional)	006-2470BL	
				Moisture Assembly (Ref 4-7)			030-4643C

### Installation Options B → G

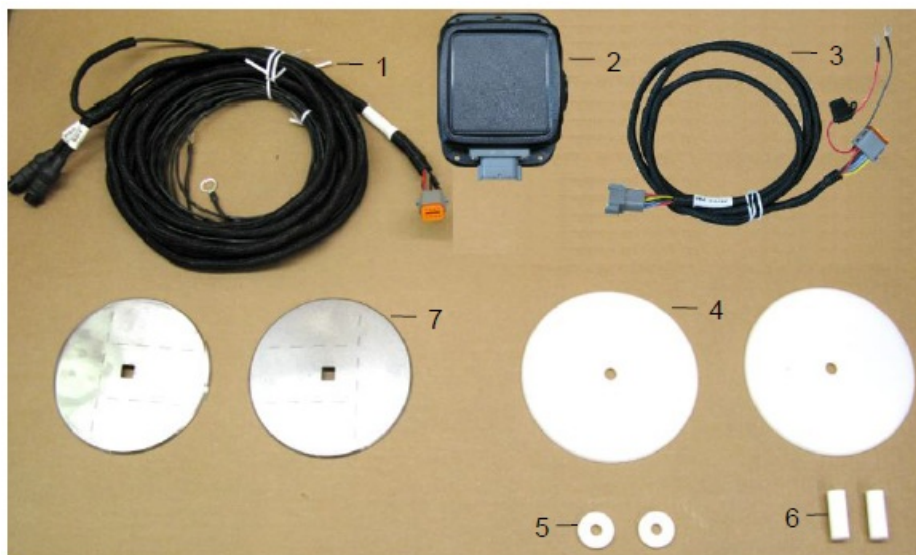

<u>Ref</u>	<u>Description</u>	<u>Part #</u>	<u>Qty</u>	<u>Ref</u>	<u>Description</u>	<u>Part #</u>	<u>Qty</u>
1	Baler Pwr/Comm Harness	006-2470RB	1	5	Plastic Isolator	006-4641I	2
2	201 Series Control Box	006-2473RB	1	6	Plastic Bushing	006-4641G	2
3	Tractor Power Harness	006-2470P	1	7	Moisture Disc	006-4641H	2
4	Plastic Pad	006-4641F	2	NP	8' Pwr/Comm Ext.	006-2470BL	

### (optional)

Moisture Assembly (Ref 4-7) 030-4643

### Fixed Chamber End of Bale Sensor Kit

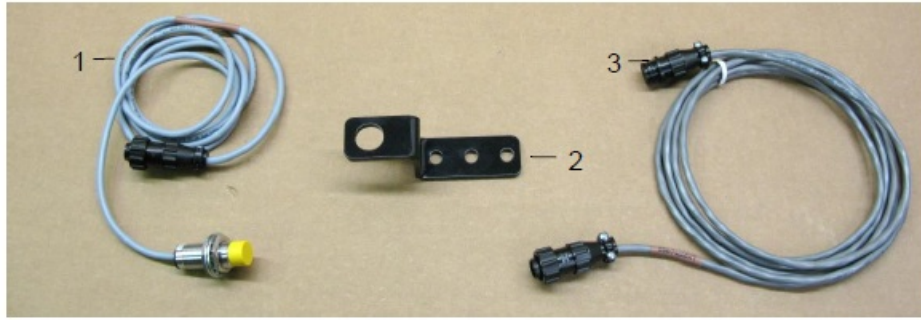

Ref	Description	Part #	Qty	Ref	Description	Part #	Qty
1	End of Bale Sensor	006-7400	1	3	EOB Extension	006-7400EXT	1
2	End of Bale Bracket	001-4648RB	1		Complete Kit	200FCA	

### Precision Moisture Dye Marker

Ref	Description	Part #	Qty	Ref	Description	Part #	Qty
1	H2O Harness (10')	006-2470C	1	8	1/4" Street Elbow	003-SE14F	2
2	Tank & Pump	005-9015	1	9	Check Valve	007-1207VB	2
3	Nozzle Cap	004-4723	4	10	1/4" Straight Fitting	003-A1414VB	2
4	Tip – Yellow	004-TX-26	2	11	Push Switch	006-2850	1
5	Tip Strainer (Green)	004-1203-100	2	12	1/4" All Barb Tee	003-T1414	1
6	Nozzle Body	004-4722	2	13	Mini Hose Clamp	003-9002	6
7	Nozzle Holder	001-4215	2	14	1/4" Hose	002-9006	40
				NP	Red Dye	009-0800	1
				NP	End of Bale Sensor Kit	200FCA	1
					Complete Assembly	030-200DM	

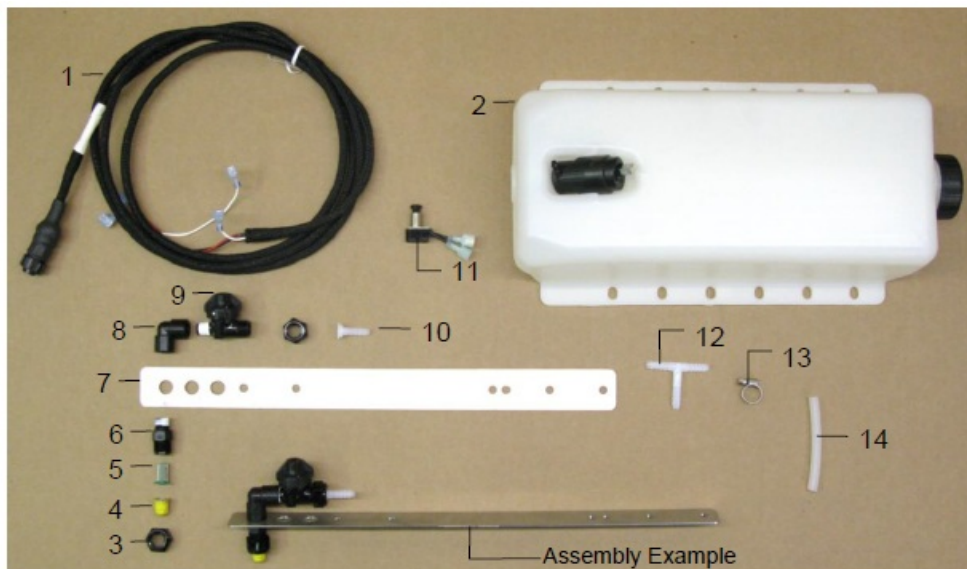



## Warranty and Liability Agreement

### Harvest Tec LLC. Warranty and Liability Agreement

Harvest Tec, LLC. will repair or replace components that are found to be defective within 12 months from the date of manufacture. Under no circumstances does this warranty cover any components which in the opinion of Harvest Tec, LLC. have been subjected to negligent use, misuse, alteration, accident, or if repairs have been made with parts other than those manufactured and obtainable from Harvest Tec, LLC.

Our obligation under this warranty is limited to repairing or replacing free of charge to the original purchaser any part that in our judgment shows evidence of defective or improper workmanship, provided the part is returned to Harvest Tec, LLC. within 30 days of the failure. If it is determined that a non-Harvest Tec branded hay preservative has been used inside the Harvest Tec applicator system where the failure occurred, then Harvest Tec reserves the right to deny the warranty request at their discretion. Parts must be returned through the selling dealer and distributor, and transportation charges prepaid.

This warranty shall not be interpreted to render Harvest Tec, LLC. liable for injury or damages of any kind, direct, consequential, or contingent, to persons or property. Furthermore, this warranty does not extend to loss of crop, losses caused by delays or any expense prospective profits or for any other reason. Harvest Tec, LLC. shall not be liable for any recovery greater in amount than the cost or repair of defects in workmanship. There are no warranties, either expressed or implied, of merchantability or fitness for a particular purpose intended or fitness for any other reason.

This warranty cannot guarantee that existing conditions beyond the control of Harvest Tec, LLC. will not affect our ability to obtain materials or manufacture necessary replacement parts. Harvest Tec, LLC. reserves the right to make design changes, improve design, or change specifications, at any time without any contingent obligation to purchasers of machines and parts previously sold.

Revised 6/22

### HARVEST TEC, LLC.

- P.O. BOX 63 2821 HARVEY STREET HUDSON, WI 54016 USA
- **PHONE:** [715-386-9100](tel:715-386-9100)
- **FAX:** [715-381-1792](tel:715-381-1792)
- **Email:** [info@harvesttec.com](mailto:info@harvesttec.com).

### Documents / Resources

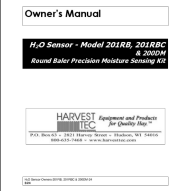
	<p><a href="#">HARVEST TEC 201RB H2O Sensor</a> [pdf] Owner's Manual 201RB, 201RBC, 200DM, 201RB H2O Sensor, 201RB, H2O Sensor, Sensor</p>
---	--

### References

- [User Manual](#)

This website is an independent publication and is neither affiliated with nor endorsed by any of the trademark owners. The "Bluetooth®" word mark and logos are registered trademarks owned by Bluetooth SIG, Inc. The "Wi-Fi®" word mark and logos are registered trademarks owned by the Wi-Fi Alliance. Any use of these marks on this website does not imply any affiliation with or endorsement.