

Fibocom
MC610 Series
Empower Global
Roaming Trackers



Fibocom MC610 Series Empower Global Roaming Trackers User Guide

[Home](#) » [Fibocom](#) » [Fibocom MC610 Series Empower Global Roaming Trackers User Guide](#) 

Contents

- [1 Fibocom MC610 Series Empower Global Roaming Trackers](#)
- [2 Product Information](#)
- [3 Product Usage Instructions](#)
- [4 About This Document](#)
- [5 Product Overview](#)
- [6 RF Interface](#)
- [7 Structural Specification](#)
- [8 RF PCB Design](#)
- [9 Appendix A](#)
- [10 FCC STATEMENT](#)
- [11 More Information](#)
- [12 FAQ](#)
- [13 Documents / Resources](#)
 - [13.1 References](#)

Fibocom

Fibocom MC610 Series Empower Global Roaming Trackers



Product Information

Specifications

- Product Name: MC610 Series Wireless Module
- Manufacturer: Fibocom Wireless Inc.
- Model: MC610
- Website: <https://www.fibocom.com>
- Contact Address: 10/F-14/F, Block A, Building 6, Shenzhen International Innovation Valley, Dashi First Road, Xili Community, Xili Subdistrict, Nanshan District, Shenzhen
- Contact Tel: 0755-26733555

Product Information

The MC610 series wireless module is designed to provide information on electrical characteristics, RF performance, structural dimensions, application environment, and more. This document, along with related materials, aids application developers in understanding the hardware functions of the MC610 series modules and developing products efficiently.

Product Usage Instructions

Safety Instructions

- Ensure road safety by not using handheld mobile terminal equipment while driving.
- Turn off wireless functions on mobile terminals before boarding aircraft to prevent interference with communication systems.
- Check for restrictions on mobile terminal use in hospitals or health care facilities to avoid RF interference with medical devices.

- In emergency situations, use the emergency call feature on your device with sufficient signal strength.
- Avoid placing mobile terminal equipment near flammable gases to prevent potential safety hazards.
- Keep mobile terminal equipment away from electronic devices to avoid RF interference.

References

- 3GPP TS 51.010-1 V10.5.0: Mobile Station (MS) conformance specification; Part 1: Conformance specification
- 3GPP TS 36.521-1 V13.6.0: User Equipment (UE) conformance specification; Radio transmission and reception; Part 1: Conformance testing

About This Document

Description

This document describes information on electrical characteristics, RF performance, structural dimension, application environment, etc. of the MC610 series wireless module. With the help of this document and other related documents, the application developer can quickly understand the hardware functions of MC610 series modules and develop the hardware of the product.

Safety Instructions

Observing the following safety principles can ensure personal safety and be conducive to protecting products and work environment from potential damages. Product manufacture should communicate the following safety instructions to end users. If these safety principles are not followed, Fibocom Wireless Inc. will not be responsible for the consequences caused by incorrect use of users.



- Road safety first! When you are driving, do not use handheld mobile terminal equipment, even if it has a hands-free function.
- Please stop and then call!



- Please turn off the mobile terminal equipment before boarding. The wireless function of the mobile terminal is forbidden to be turned on in the aircraft to prevent interference with aircraft communications system.
- Ignoring the prompt may lead to flight unsafety and even violation of the law.



- Please pay attention to whether there are restrictions on the use of the mobile terminal equipment when in hospitals or health care facilities. RF interference may cause abnormal operation of medical devices. Therefore, it is possible to turn off the mobile terminal equipment.



- The mobile terminal equipment does not guarantee effective connection under any circumstances, for example, when the mobile terminal equipment is defaulted or (U) SIM is invalid.
- In case of the above situations in an emergency, remember to use the emergency call, and make sure your device is turned on and in an area of sufficient signal strength.



- Your mobile terminal equipment will receive and transmit RF signals when it is turned on. RF interference occurs when it is close to televisions, radios, computers or other electronic devices



- Keep the mobile terminal equipment away from flammable gases. Please turn off the mobile terminal equipment when it is near gas stations, oil depots, chemical plants or explosive workplaces.
- There are potential safety hazards in the operation of electronic devices in any potential explosion hazard area.

References

This product is designed with reference to the following standards:

- 3GPP TS 51.010-1 V10.5.0: Mobile Station (MS) conformance specification; Part 1: Conformance specification
- 3GPP TS 36.521-1 V13.6.0: User Equipment (UE) conformance specification; Radio transmission and reception; Part 1: Conformance testing
- 3GPP TS 21.111 V10.0.0: USIM and IC card requirements
- 3GPP TS 51.011 V4.15.0: Specification of the Subscriber Identity Module -Mobile Equipment (SIM-ME) interface
- 3GPP TS 31.102 V10.11.0: Characteristics of the Universal Subscriber Identity Module (USIM) application
- 3GPP TS 31.11 V10.16.0: Universal Subscriber Identity Module (USIM) Application Toolkit(USAT)
- 3GPP TS 36.124 V10.3.0: Electro Magnetic Compatibility (EMC) requirements for mobile terminals and ancillary equipment
- 3GPP TS 27.007 V10.0.8: AT command set for User Equipment (UE)
- 3GPP TS 27.005 V10.0.1: Use of Data Terminal Equipment – Data Circuit terminating Equipment (DTE – DCE) interface for Short Message Service (SMS) and Cell Broadcast Service (CBS)

Related Documents

- Fibocom_MC610_ADP User Guide
- FIBOCOM_MC610_SMT Design Guide
- FIBOCOM_Design Guide_RF Antenna
- FIBOCOM_MC610_AT Commands
- FIBOCOM_MC610 GPIO Function Multiplexing
- FIBOCOM_MC610_Reference Design

Product Overview

Product Introduction

MC610 series module is a kind of broadband wireless terminal product suitable for TDD-LTE/FDD-LTE multiple network systems and multiple bands.

Item	LTE FDD	LTE TDD	GSM	ANT
MC610 GL	Band 1, 2, 3, 4, 5, 7, 8, 12, 13, 17, 18, 19, 20, 25, 26, 28, 66	Band 34, 38, 39, 40, 41	850/900/1800/1900	Main

Info: MC610 has 4MB Flash+8MB RAM, The support for Open functionality should be determined based on the specific model.

Product Specification

Table 1. Product specification

Operating band	See Section 2.1 for details.	
Data transmission	LTE FDD Rel.13	DL/UL 10.3 Mbps (20M) /5.1 Mbps (10M)
	LTE TDD Rel.13	9.1Mbps DL/3.1Mbps UL
	GPRS	85.6Kbps DL/85.6Kbps UL
Power	3.4 V to 4.3 V (recommended value: 3.8 V)	
Temperature	Normal operation: -35°C to +75°C	
	Extended operation: -40°C to +85°C	
	Storage: -40°C to +90°C	
Power consumption	Sleep mode: 2.2mA	
Physical characteristics	Package: LCC 52PIN+LGA 76PIN	
	Dimensions: 24.2 mm × 26.2 mm × 2.1 mm	
	Weight: about 2 g.	
Interface		
Antenna	Antenna: Main set ×1	
Functional interface	USIM3.0V/1.8V ×2	
	USB2.0 × 1	

	System state indicator
	ADCx4, UARTx3, I2C, SPI, KEY, SPK, MIC, HEADMIC, HP, SDIO
Software	
Protocol stack	Embedded TCP/IP and UDP/IP protocol stack
AT command	3GPP TS 27.007 and 27.005, and proprietary FIBOCOM AT
Firmware update	USB
Voice service	HR, FR, EFR, AMR, caller display, call transfer, call holding, call waiting, multi-party call, et c.
SMS business	Point-to-point MO, MT, cell broadcast, support Text and PDU mode

Note

- When the temperature exceeds the normal operating temperature range of -30°C to +75°C, the RF performance of the module may slightly exceed the 3GPP specification.
- Some functionals such as SPK, MIC, HEADMIC, HP, SD,LCD,CAM, BT,etc. are not supported, and the antenna tuning function is added.

RF Interface

MC610 Working Frequency

Table 2. Working frequency

Operating Band	Description	Mode	Tx (MHz)	Rx (MHz)
Band 1	IMT 2100MHz	LTE FDD	1920 – 1980	2110 – 2170
Band 2	PCS 1900 MHz	LTE FDD/GSM	1850 – 1910	1930 – 1990
Band 3	DCS 1800MHz	LTE FDD/GSM	1710 – 1785	1805 – 1880
Band 4	AWS-1 1700	LTE FDD	1710 – 1755	2110 – 2155
Band 5	CLR 850MHz	LTE FDD/GSM	824 – 849	869 – 894
Band 7	IMT-E 2600MHz	LTE FDD	2500 – 2570	2620 – 2690

Band 8	E-GSM 900MHz	LTE FDD/GSM	880 – 915	925 – 960
Band 12	Lower SMH blocks A	LTE FDD	699 – 716	729 – 746
Band 13	Upper SMH block C	LTE FDD	777 – 787	746 – 756
Band 17	Lower SMH blocks B	LTE FDD	704 – 716	734 – 746
Band 18	Japan lower 800	LTE FDD	815 – 830	860 – 875
Band 19	Japan upper 800	LTE FDD	830 – 845	875 – 890
Band 20	EU Digital Dividend 800 MHz	LTE FDD	832-862	791-821
Band 25	Extended PCS blocks A-G	LTE FDD	1850 – 1915	1930 – 1995
Band 26	Extended CLR	LTE FDD	814 – 849	859 – 894
Band 28	APAC 700MHz	LTE FDD	703 – 748	758 – 803
Band 34	IMT 2100MHz	LTE TDD	2010 – 2025	
Band 38	IMT 2595MHz	LTE TDD	2570- 2620	
Band 39	TDD 1900MHZ	LTE TDD	1880 – 1920	
Band 40	IMT 2300MHz	LTE TDD	2300 – 2400	
Band 41	BRS/EBS 2500MHZ	LTE TDD	2496 – 2690	
Band 66	AWS-1 1700	LTE FDD	1710 – 1780	2110 – 2180

RF Output Power of MC610

The RF output power of MC610 series modules is shown in the following table.

Table 3. Output power

Mode	Band	Tx Power(dBm)	Note
	GSM 850	33±2	PCL 5
	GSM 900	33±2	PCL 5

GSM	DCS 1800	30±2	PCL 0
	PCS 1900	30±2	PCL 0
LTE FDD	Band 1	23±2	10MHz Bandwidth, 1 RB
	Band 2	23±2	10MHz Bandwidth, 1 RB
	Band 3	23±2	10MHz Bandwidth, 1 RB
	Band 4	23±2	10MHz Bandwidth, 1 RB
	Band 5	23±2	10MHz Bandwidth, 1 RB
	Band 7	23±2	10MHz Bandwidth, 1 RB
	Band 8	23±2	10MHz Bandwidth, 1 RB
	Band 12	23±2	10MHz Bandwidth, 1 RB
	Band 13	23±2	10MHz Bandwidth, 1 RB
	Band 17	23±2	10MHz Bandwidth, 1 RB
	Band 18	23±2	10MHz Bandwidth, 1 RB
	Band 19	23±2	10MHz Bandwidth, 1 RB
	Band 20	23±2	10MHz Bandwidth, 1 RB
	Band 25	23±2	10MHz Bandwidth, 1 RB
	Band 26	23±2	10MHz Bandwidth, 1 RB
	Band 28	23±2	10MHz Bandwidth, 1 RB
Band 66	23±2	10MHz Bandwidth, 1 RB	
LTE TDD	Band 34	23±2	10MHz Bandwidth, 1 RB
	Band 38	23±2	10MHz Bandwidth, 1 RB
	Band 39	23±2	10MHz Bandwidth, 1 RB
	Band 40	23±2	10MHz Bandwidth, 1 RB

	Band 41	23±2	10MHz Bandwidth, 1 RB
--	---------	------	-----------------------

Structural Specification

Product Appearance

The appearance of MC610 series modules is shown in the figure:



Figure 1. Module product appearance (top)

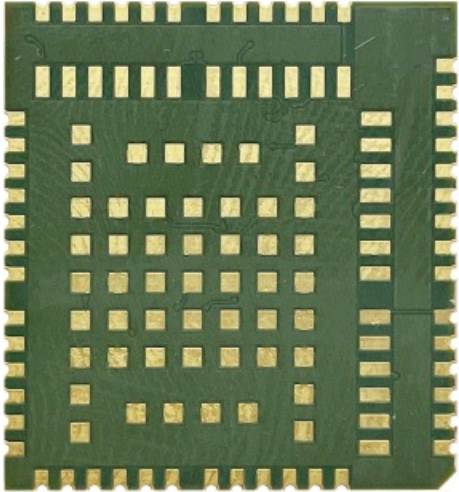

Structure Size

The structure size of MC610 series modules is shown in the following figure:

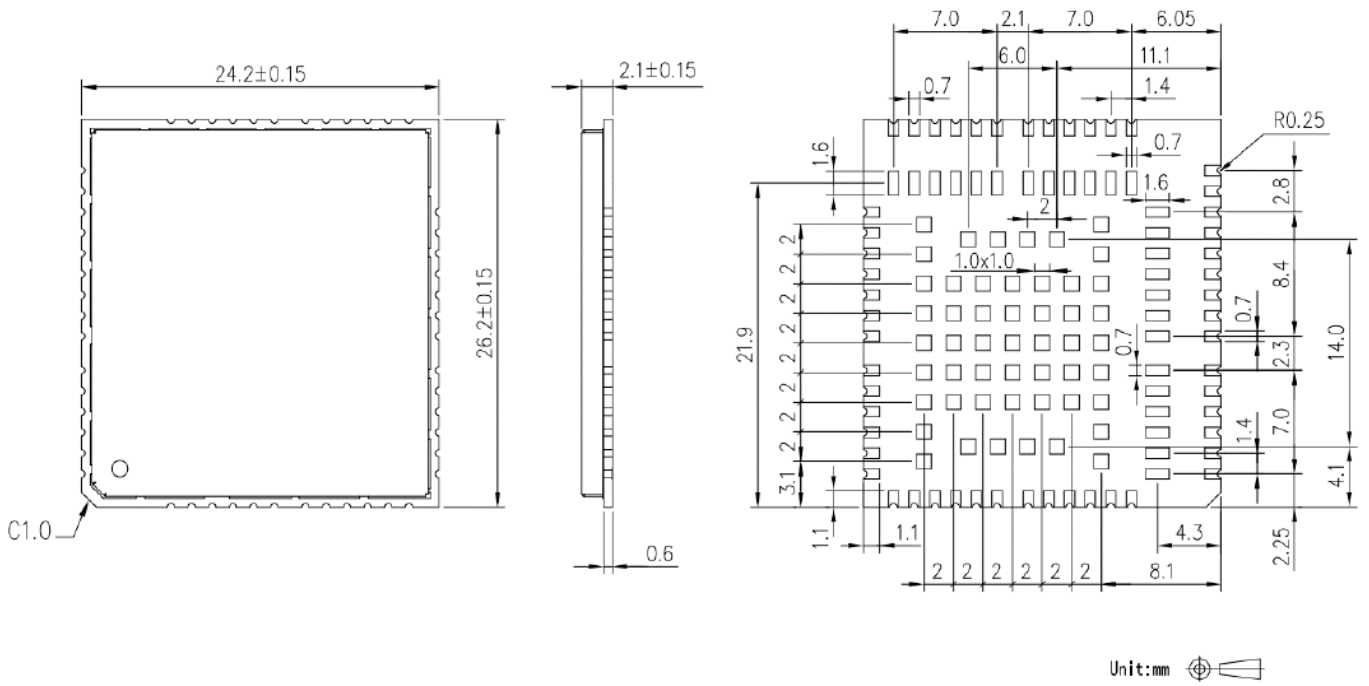

Figure 3. Structural dimension drawing (unit: mm)

RF PCB Design

Antenna RF Connector

The antenna of the MC610 series modules is led from bonding pads. It is recommended that customers use the U.FL-R-SMT-1 antenna connector and use the matching RF adapter lines.

The antenna is a sensitive device and is easily affected by the external environment. For example, the position of the antenna, the occupied space, and the surrounding grounding may affect the performance of the antenna. In addition, the RF cable connected to the antenna and the fixed antenna position will also affect the antenna performance.

Figure 23 shows the reference circuit design of the main set antenna. These matches need to be placed close to the antenna:

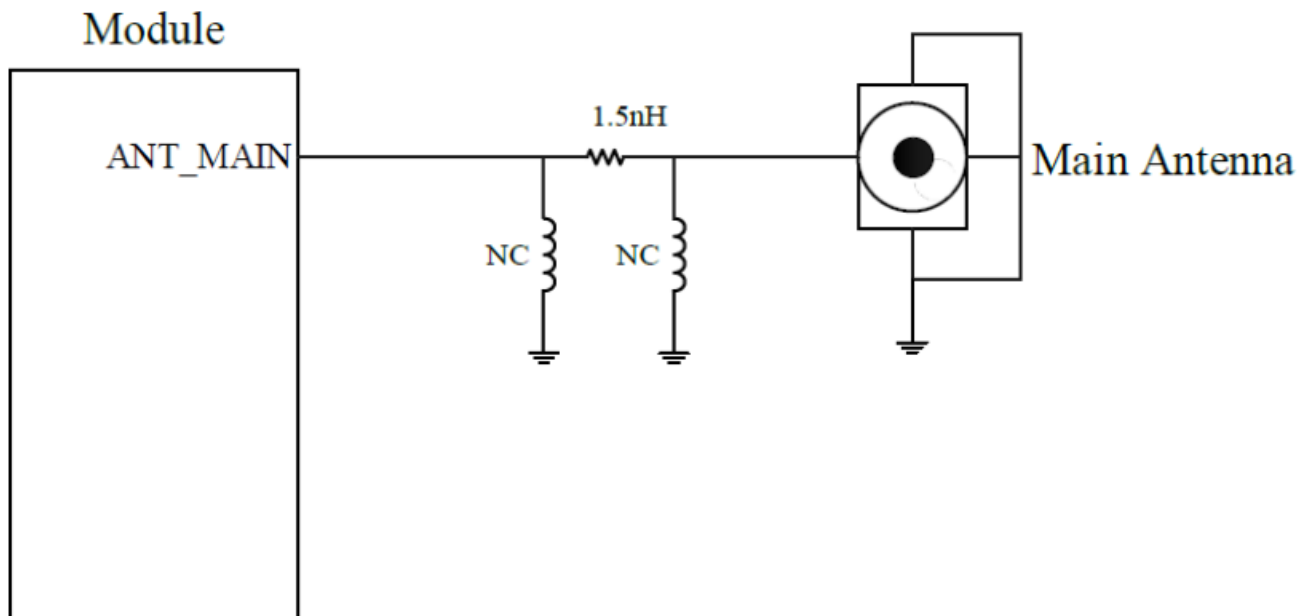

Figure 4. RF reference circuit design

- Ensure that the characteristic impedance of the transmission line is 50 Ω .
- As the antenna line loss is less than 0.3 dB, keep the PCB routes as short as possible.
- PCB LAYOUT avoids passing through holes and overturning layers as much as possible, and also right-angle and acute-angle route.
- There should be a good reference ground around the PCB routes to avoid other signal lines close to the antenna.
- It is recommended to use intact formations as reference ground.
- The ground around the antenna strengthens the connection with the main ground.

Appendix A

Appendix A RED Conformance information

Exposure

- The device could be used with a separation distance of 20 cm to the human body.

Declaration of conformity

- Hereby, [Fibocom Wireless Inc.] declares that the radio equipment type [Model Name: MC610] is in compliance with Directive 2014/53/EU.
- For the declaration of conformity, visit the Web site www.fibocom.com/certification.

FCC STATEMENT

Appendix B: FCC Conformance information

Federal Communication Commission Interference Statement

This device complies with Part 15 of the FCC Rules. Operation is subject to the following two conditions: (1) This device may not cause harmful interference, and (2) this device must accept any interference received, including interference that may cause undesired operation.

This equipment has been tested and found to comply with the limits for a Class B digital device, pursuant to Part 15 of the FCC Rules. These limits are designed to provide reasonable protection against harmful interference in a residential installation. This equipment generates, uses and can radiate radio frequency energy and, if not installed and used in accordance with the instructions, may cause harmful interference to radio communications. However, there is no guarantee that interference will not occur in a particular installation. If this equipment does cause harmful interference to radio or television reception, which can be determined by turning the equipment off and on, the user is encouraged to try to correct the interference by one of the following measures:

- Reorient or relocate the receiving antenna.
- Increase the separation between the equipment and receiver.
- Connect the equipment into an outlet on a circuit different from that to which the receiver is connected.
- Consult the dealer or an experienced radio/TV technician for help.

Any changes or modifications not expressly approved by the party responsible for compliance could void the user's authority to operate this equipment. This transmitter must not be co-located or operating in conjunction with any other antenna or transmitter.

This device is intended only for OEM integrators under the following conditions:

1. The antenna must be installed such that 20 cm is maintained between the antenna and users,
2. The transmitter module may not be co-located with any other transmitter or antenna.

As long as 2 conditions above are met, further transmitter test will not be required. However, the OEM integrator is still responsible for testing their end-product for any additional compliance requirements required with this module installed.

Radiation Exposure Statement

- This equipment complies with FCC radiation exposure limits set forth for an uncontrolled environment.
- This equipment should be installed and operated with minimum distance 20 cm between the radiator & your body.

Important Notice to OEM integrators

1. This module is limited to OEM installation ONLY.
2. This module is limited to installation in mobile applications, according to Part 2.1091(b).
3. The separate approval is required for all other operating configurations, including portable configurations with respect to Part 2.1093 and different antenna configurations
4. **For FCC Part 15.31 (h) and (k):** The host manufacturer is responsible for additional testing to verify compliance as a composite system. When testing the host device for compliance with Part

15 Subpart B, the host manufacturer is required to show compliance with Part 15 Subpart B while the transmitter module(s) are installed and operating. The modules should be transmitting and the evaluation should confirm that the module's intentional emissions are compliant (i.e. fundamental and out of band emissions). The host manufacturer must verify that there are no additional unintentional emissions other than what is permitted in Part

15 Subpart B or emissions are complaint with the transmitter(s) rule(s).

The Grantee will provide guidance to the host manufacturer for Part 15 B requirements if needed.

Important Note

Notice that any deviation(s) from the defined parameters of the antenna trace, as described by the instructions, require that the host product manufacturer must notify to Fibocom Wireless Inc. that they wish to change the antenna trace design. In this case, a Class II permissive change application is required to be filed by the USI, or the host manufacturer can take responsibility through the change in FCC ID (new application) procedure followed by a Class II permissive change application.

End Product Labeling

When the module is installed in the host device, the FCC ID label must be visible through a window on the final device or it must be visible when an access panel, door or cover is easily re-moved. If not, a second label must be placed on the outside of the final device that contains the following text: "Contains FCC ID:ZMOMC610"

The FCC ID can be used only when all FCC compliance requirements are met.

Antenna Installation

1. The antenna must be installed such that 20 cm is maintained between the antenna and users,
2. The transmitter module may not be co-located with any other transmitter or antenna.
3. Only antennas of the same type and with equal or less gains as shown below may be used with this module.
Other types of antennas and/or higher gain antennas may require additional authorization for operation.

Band	Antenna Gain (dBi)
LTE band 2&GSM1900	1.00
LTE band 4	2.98
LTE band 5&GSM850	1.32
LTE band 7	2.21
LTE band 12	1.61
LTE band 13	1.83
LTE band 17	1.61
LTE band 25	2.27
LTE band 26	1.32
LTE band 38	1.71
LTE band 41	2.21
LTE band 66	2.98

In the event that these conditions cannot be met (for example certain laptop configurations or co-location with another transmitter), then the FCC/IC authorization is no longer considered valid and the FCC ID/IC ID cannot be used on the final product. In these circumstances, the OEM integrator will be responsible for re-evaluating the end product (including the transmitter) and obtaining a separate FCC/IC authorization.

Manual Information to the End User

The OEM integrator has to be aware not to provide information to the end user regarding how to install or remove this RF module in the user's manual of the end product which integrates this module. The end user manual shall include all required regulatory information/warning as show in this manual.

Information to user

Warning: changes or modifications not expressly approved by the party responsible for compliance could void the user's authority to operate the equipment.

List of applicable FCC rules:

- 47CFRPart 22, 24, 27, 90, 96

Summarize the specific operational use conditions:

- This module can be used in IOT devices, the input voltage to the module is nominally 3.8V.

Limited module procedures:

- This module is a single module.

Trace antenna designs:

- The antenna is not a trace antenna.

RF exposure considerations:

This Module complies with FCC radiation exposure limits set forth for an uncontrolled environment. This equipment should be installed and operated with a minimum distance of 20cm between the radiator and your body. This transmitter must not be co-located or operating in conjunction with any other antenna or transmitter.

Antennas:

If you desire to increase antenna gain and either change antenna type or use same antenna type certified, a Class II permissive change application is required to be filed by us, or you (host manufacturer) can take responsibility through the change in FCC ID (new application) procedure followed by a Class II permissive change application.

Label and compliance information:

Please notice that if the FCC identification number is not visible when the module is installed inside another device, then the outside of the device into which the module is installed must also display a label referring to the enclosed module. This exterior label can use wording such as the following: "Contains FCC ID: ZMOMC610" any

similar wording that expresses the same meaning may be used.

15.19 Labelling requirements shall be complied on end user device.

- Labelling rules for special device, please refer to §2.925, § 15.19 (a)(5) and relevant KDB publications. For E-label, please refer to §2.935.

Information on test modes and additional testing requirements:

- The OEM integrator is responsible for ensuring that the end-user has no manual instruction to remove or install module.
- The module is limited to installation in mobile application, a separate approval is required for all other operating configurations, including portable configurations with respect to §2.1093 and difference antenna configurations.

More Information

Trademark Statement

 The trademark is registered and owned by Fibocom Wireless Inc. Other trademarks, product names, service names and company names appearing in this document are owned by their respective owners.

Contact Information

- **Website:** <https://www.fibocom.com>
- **Address:** 10/F-14/F, Block A, Building 6, Shenzhen International Innovation Valley, Dashi First Road, Xili Community, Xili Subdistrict, Nanshan District, Shenzhen
- **Tel:** 0755-26733555

www.fibocom.com

FAQ

- **Q:** What should I do if my mobile terminal equipment does not guarantee effective connection?
 - **A:** In such cases, use the emergency call feature on your device and ensure it is turned on in an area with sufficient signal strength.
- **Q:** How can I prevent RF interference when using mobile terminal equipment?
 - **A:** Keep the device away from televisions, radios, computers, or other electronic devices to avoid RF interference.

Copyright © Fibocom Wireless Inc.

Documents / Resources

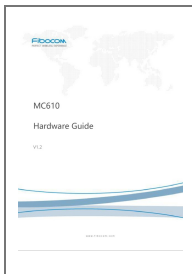

[Fibocom MC610 Series Empower Global Roaming Trackers](#) [pdf] User Guide
MC610 Series Empower Global Roaming Trackers, MC610 Series, Empower Global Roaming Trackers, Global Roaming Trackers, Roaming Trackers, Trackers

References

- [F .](#)
- [F Global Leading Wireless Modules & IoT Solutions - Fibocom](#)
- [User Manual](#)

[Manuals+](#), [Privacy Policy](#)

This website is an independent publication and is neither affiliated with nor endorsed by any of the trademark owners. The "Bluetooth®" word mark and logos are registered trademarks owned by Bluetooth SIG, Inc. The "Wi-Fi®" word mark and logos are registered trademarks owned by the Wi-Fi Alliance. Any use of these marks on this website does not imply any affiliation with or endorsement.