

Edgecore Networks AS9726-32DB 32 Port 400G Ethernet Switch



Edgecore Networks AS9726-32DB 32 Port 400G Ethernet Switch User Guide

[Home](#) » [Edgecore NETWORKS](#) » Edgecore Networks AS9726-32DB 32 Port 400G Ethernet Switch User Guide 

Contents

- [1 Edgecore Networks AS9726-32DB 32 Port 400G Ethernet Switch](#)
- [2 Product Usage Instructions](#)
- [3 Package Contents](#)
- [4 Overview](#)
- [5 System LEDs/Buttons](#)
- [6 Port LEDs](#)
- [7 FRU Replacement](#)
- [8 Installation](#)
- [9 Hardware Specifications](#)
- [10 Documents / Resources](#)
 - [10.1 References](#)
- [11 Related Posts](#)



Edgecore Networks AS9726-32DB 32 Port 400G Ethernet Switch



Specifications:

- **Model:** AS9726-32DB
- **Ports:** 32 x 400G QSFP-DD, 2 x 10G SFP+
- **Management Ports:** 1 x 1000BASE-T RJ-45, micro-USB/RJ-45 console, USB
- **Power Supply:** AC or DC PSU

Product Usage Instructions

Installation:

1. Mount the Switch:

1. Verify Rack Ground: Ensure proper grounding of the rack.
2. Attach Grounding Wire: Connect grounding wire to switch rear panel and rack ground.

2. Connect Power:

Attach the Brackets: Secure front- and rear-post brackets with screws.

1. Install PSU: Mount AC or DC PSUs and connect to power source.
2. Mount the Switch: Secure the switch in the rack with screws.

Fan and PSU Replacement:

1. Airflow Reversal:

- F2B Airflow: Remove F2B airflow components.
- B2F Airflow: Install B2F airflow components.

2. PSU Replacement:

1. Remove power cord.
2. Release latch and remove PSU.
3. Install replacement PSU with matching airflow direction.

3. Fan Tray Replacement:

1. Pull handle release latch.
2. Remove fan tray from chassis.
3. Install replacement fan with matching airflow direction.

Management Connections:

1. Make Management Connections as per specified ports and LEDs.

FAQ:

Q: Where can I find compatible switch software?

A: Information about compatible switch software can be found at www.edge-core.com .

Quick Start Guide

32-Port 400G Ethernet Switch AS9726-32DB

Package Contents

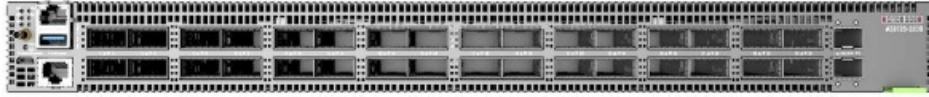

①

1. 32-Port 400G Ethernet Switch AS9726-32DB
2. Rack mounting kit—2 front-post brackets, 2 rear-post brackets and ears, 20 screws, and 2 ear-locking screws
3. Power cord (included with AC PSUs only)
4. Console cable—RJ-45 to DE-9



②



③



④

5. DC power cable (included with DC PSUs only)
6. Grounding wire
7. Documentation—Quick Start Guide (this document) and Safety and Regulatory Information



④



⑤



⑥

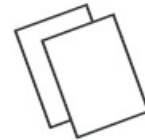

⑦

Overview

1. System LEDs and 1PPS timing port
2. Management Ports: 1 x 1000BASE-T RJ-45, micro-USB/RJ-45 console, USB
3. 32 x 400G QSFP-DD ports
4. 2 x 10G SFP+ ports

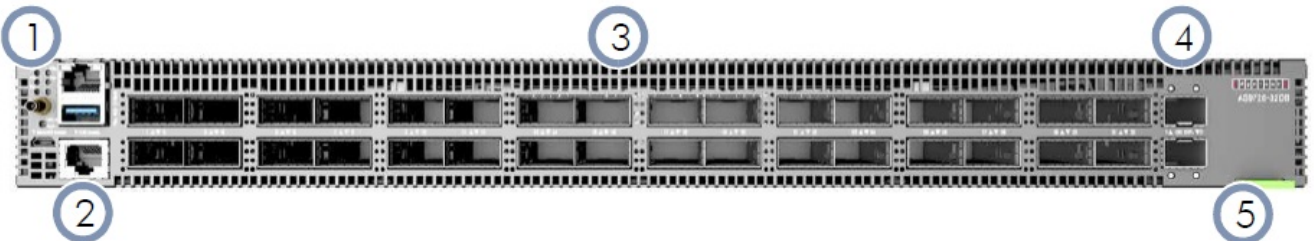

5. Product label
6. 2 x grounding screws (maximum torque 10 kgf-cm (8.7 lb-in))
7. 2 x AC or DC PSUs
8. 6 x fan trays

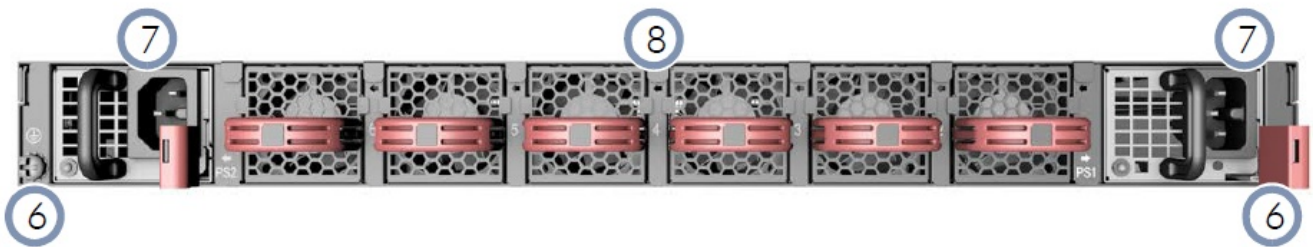

System LEDs/Buttons

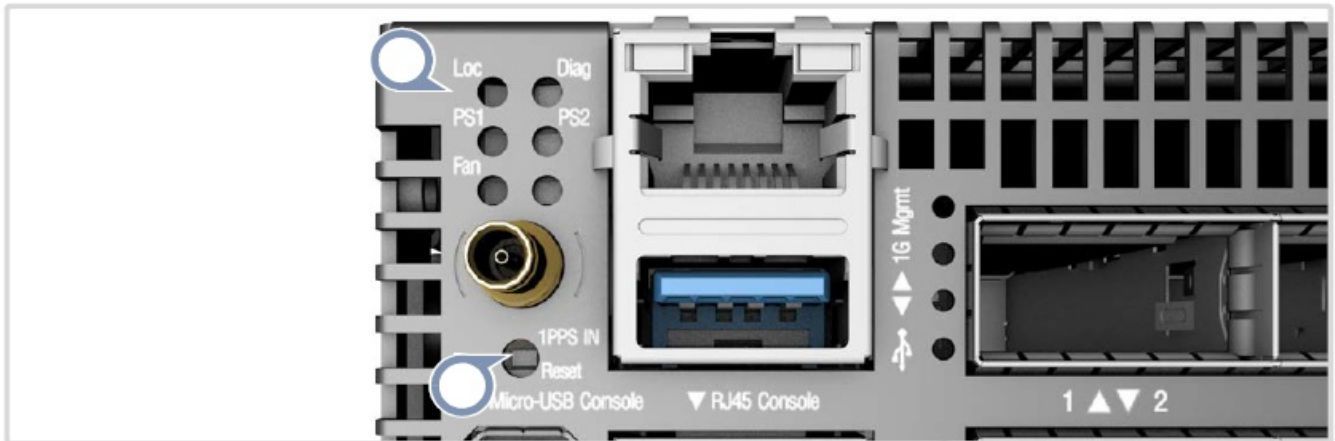

- **Loc:** Flashing Amber (switch locator)
- **Diag:** Green (OK), Amber (no OS or fault)
- **PS1/PS2:** Green (OK), Amber (fault)
- **Fan:** Green (OK), Amber (fault)
- Reset Button

Port LEDs

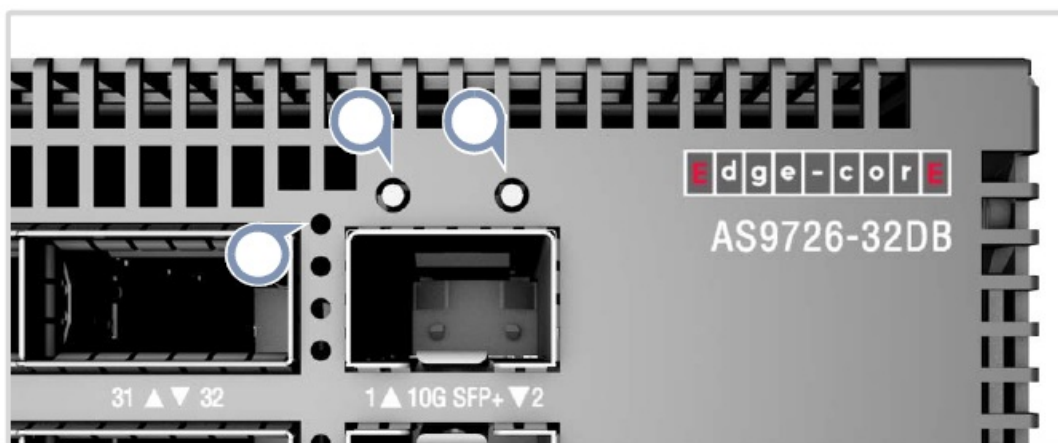

- **QSFP-DD LEDs**
 - **400G:** 1 LED Blue
 - **200G Breakout:** 1 LED White, 1-2 LEDs Green
 - **100G Breakout:** 1-4 LEDs Green
 - **50G Breakout:** 1 LED Cyan

- **SFP+ 10G LEDs**

- **Left:** Green (link)
- **Right:** Green (10G), Amber (1G)

- **RJ-45 Mgmt LEDs**

- **Left:** Green (link)
- **Right:** Green (activity)

FRU Replacement

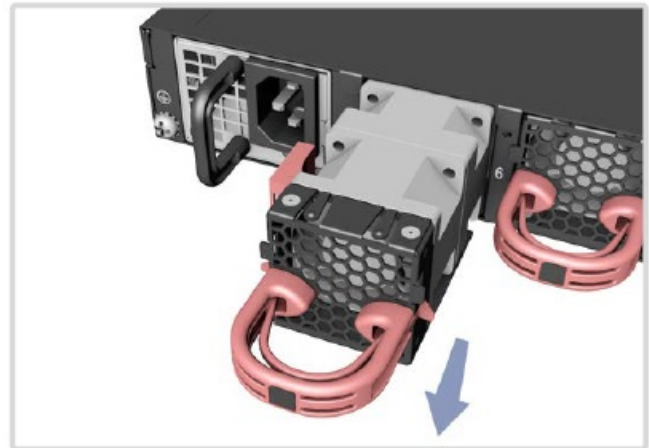
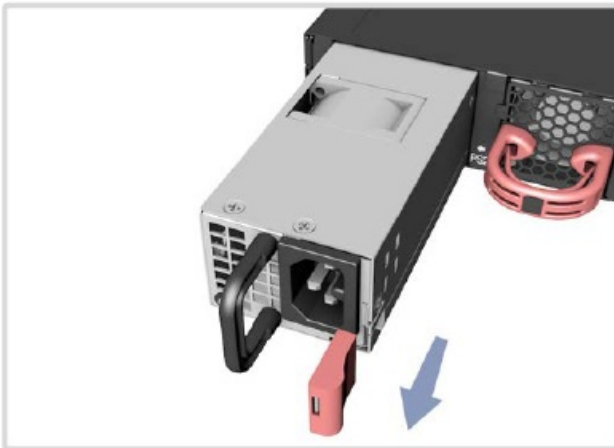

PSU Replacement

1. Remove the power cord.
2. Press the release latch and remove the PSU.
3. Install replacement PSU with matching airflow direction.

Fan Tray Replacement

1. Pull the handle release latch.
2. Remove fan tray from the chassis.
3. Install replacement fan with matching airflow direction.

Airflow Reversal

1. **F2B Airflow**



Remove front-to-back (F2B) airflow fan trays (red handles) and PSUs (red release latches).

2. **B2F Airflow**

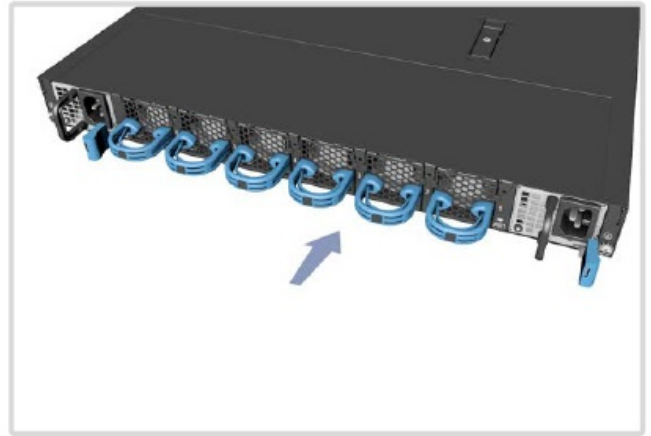
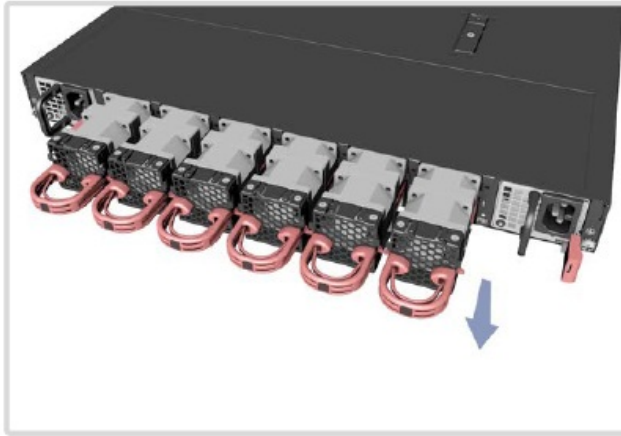
Install back-to-front (B2F) airflow fan trays (blue handles) and PSUs (blue release latches).



Installation

-  **Warning:** For a safe and reliable installation, use only the accessories and screws provided with the device. Use of other accessories and screws could result in damage to the unit. Any damages incurred by using unapproved accessories are not covered by the warranty.
-  **Caution:** The switch includes plug-in power supply (PSU) and fan tray modules that are installed into its chassis. Make sure all installed modules have a matching airflow direction (front-to-back or back-to-front).
-  **Note:** The switch has the Open Network Install Environment (ONIE) software installer preloaded on the switch, but no switch software image. Information about compatible switch software can be found at www.edgecore.com.
- **Note:** The switch drawings in this document are for illustration only and may not match your particular switch model.

1. Mount the Switch

Caution: This device must be installed in a telecommunications room or a server room where only qualified personnel have access.

1. Attach the Brackets

Use the included screws to attach the front- and rear-post brackets.

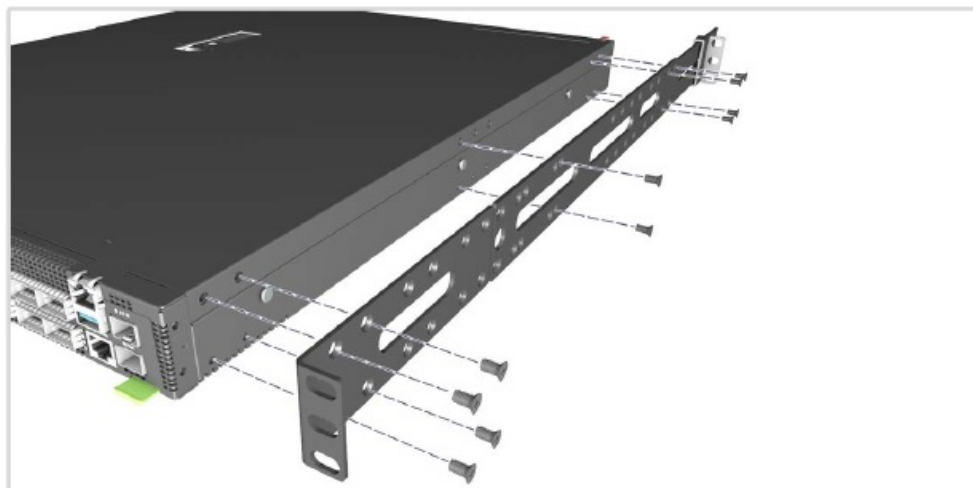

2. Mount the Switch

Mount the switch in the rack and secure it with rack screws.

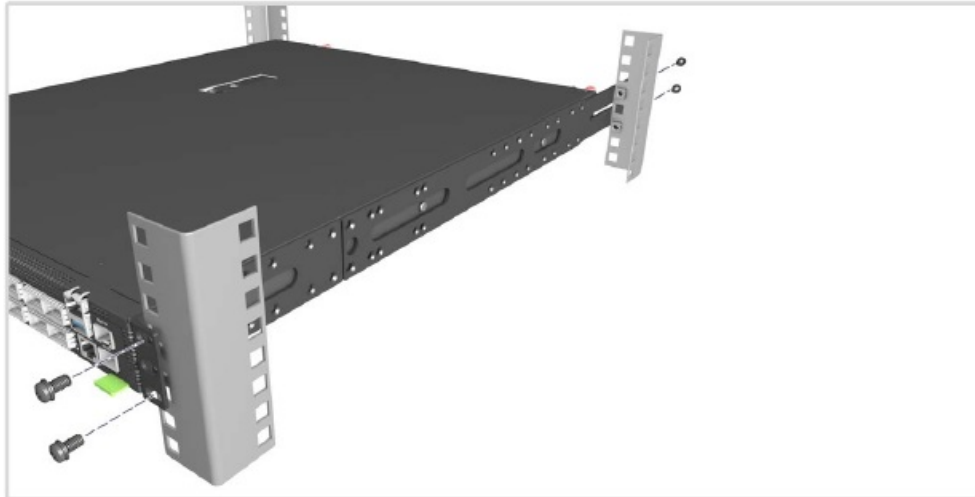

3. Lock the Rear-Post Brackets

Use the included screws to lock the position of the rear-post brackets.

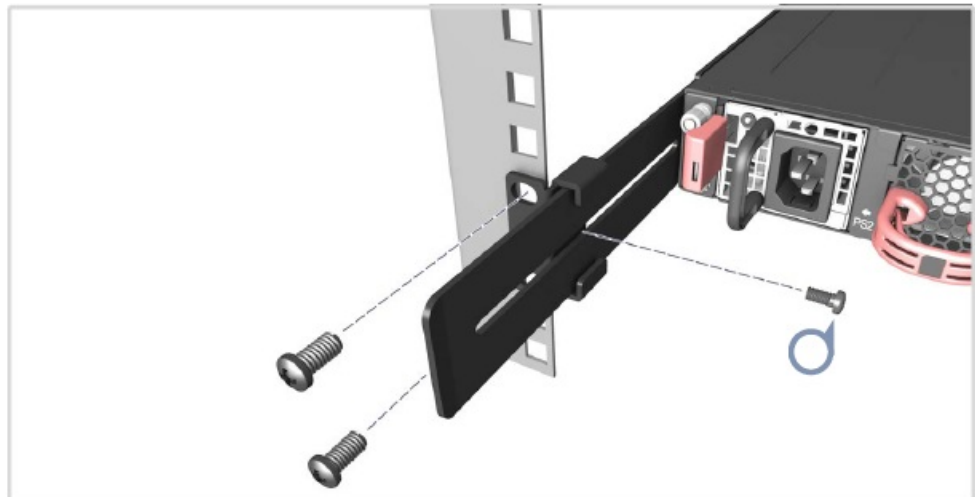

2. Ground the Switch

- **Verify Rack Ground**

Ensure the rack on which the switch is to be mounted is properly grounded and in compliance with ETSI ETS 300 253. Verify that there is a good electrical connection to the grounding point on the rack (no paint or isolating surface treatment).

- **Attach Grounding Wire**

Attach the included grounding wire to the grounding point on the switch rear panel. Then connect the other end of the wire to rack ground.



3. Connect Power

Install one or two AC or DC PSUs and connect them to an AC or DC power source.

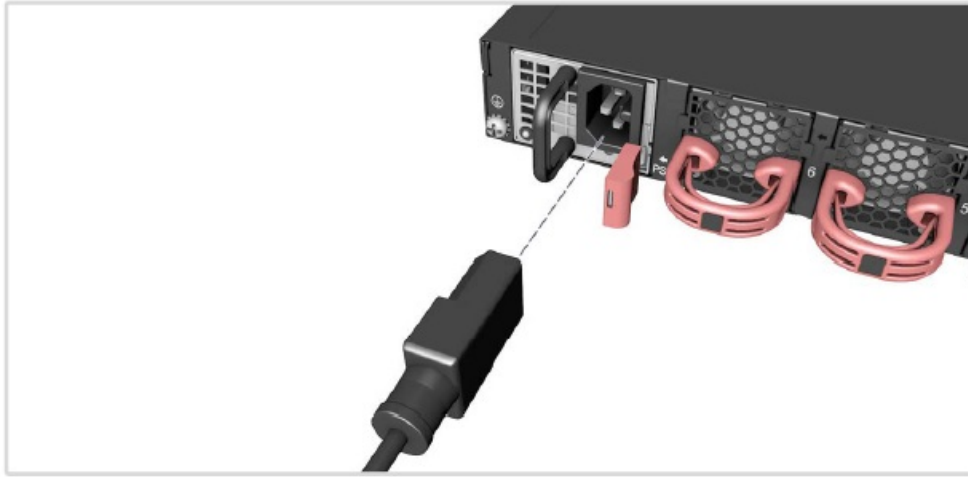

Note: When using only one AC PSU to power a fully loaded system, be sure to use a high-voltage source (220–240 VAC).

1. Use the DC power cable included with the DC PSU.
2. -40 – -75 VDC
3. DC return
4. Ground

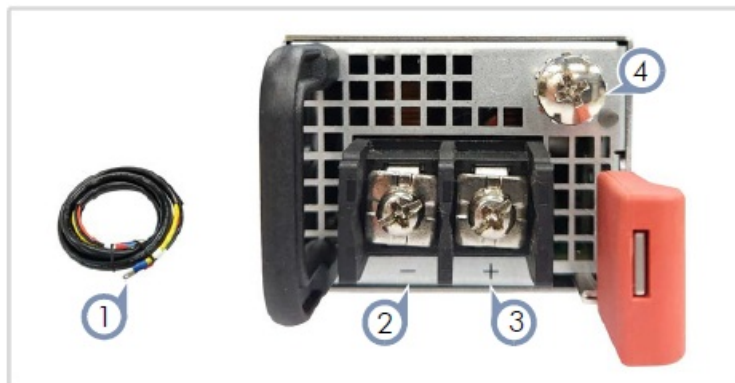

- **Caution:** Use a UL/IEC/EN 60950-1 and/or 62368-1 certified power supply to connect to a DC converter.
- **Caution:** All DC power connections should be performed by a qualified professional.
- **Note:** Use #8 AWG / 6 mm² copper wire (for a -40 to -75 VDC PSU) to connect to a DC PSU.

4. Make Network Connections

- **400G QSFP-DD Ports and 10G SFP+ Ports**

Install transceivers and then connect fiber optic cabling to the transceiver ports.

Alternatively, connect DAC or AOC cables directly to the slots.

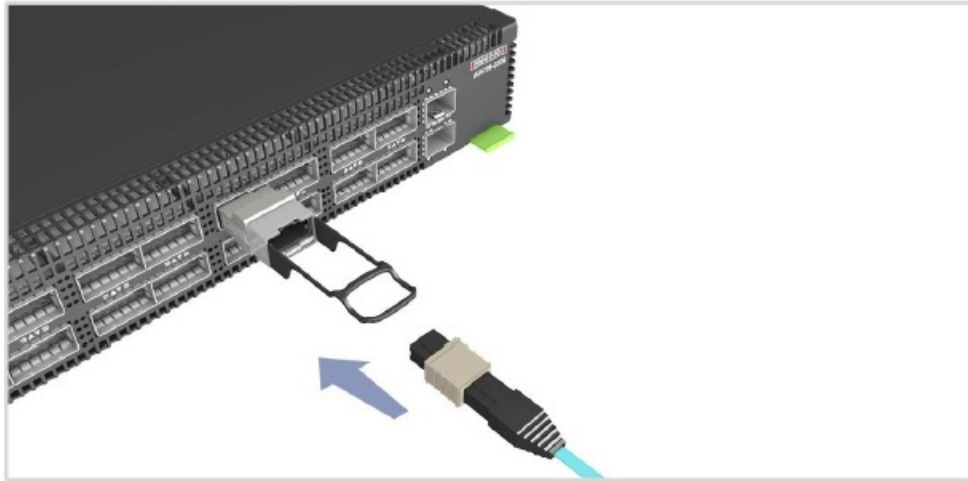

- **Note:** The upper 16 ports support up to 24 W per port, and the lower 16 ports support up to 14 W per port.

5. Connect Timing Ports

1PPS IN Port

Use a coax cable to connect the 1-pulse-per-second (1PPS) input port to another synchronized device.



6. Make Management Connections

1. 10/100/1000M RJ-45 Management Port

Connect Cat. 5e or better twisted-pair cable.

2. Micro-USB and RJ-45 Console Ports

Connect the included console cable and then configure the serial connection: 115200 bps, 8 characters, no parity, one stop bit, 8 data bits, and no flow control.

(The Micro-USB console connection takes priority over the RJ-45 console connection.)

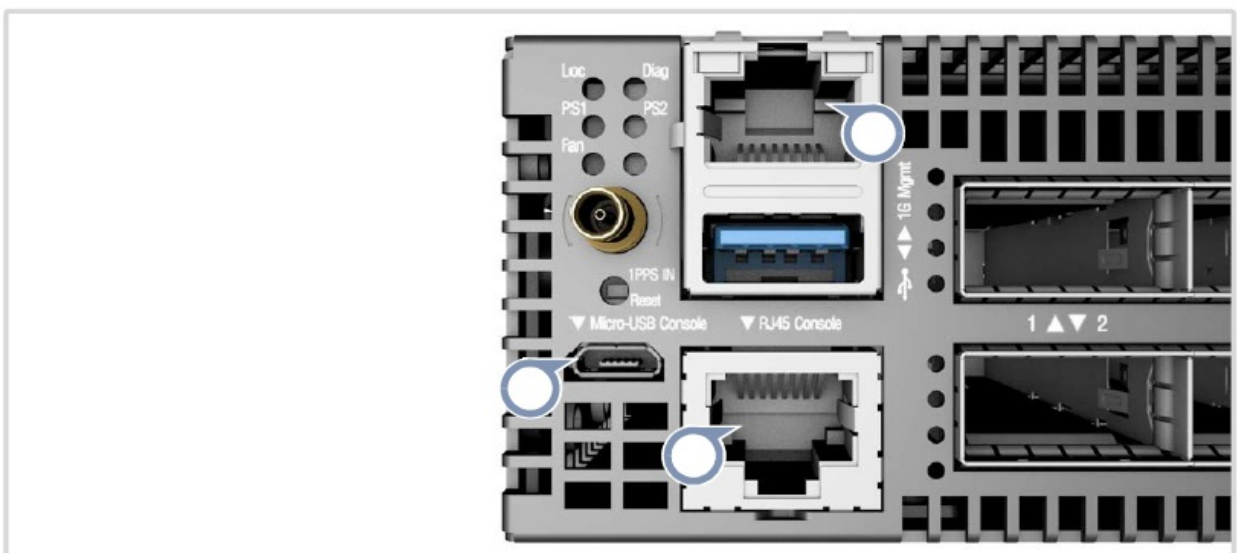

Hardware Specifications

Switch Chassis

- **Size** (WxDxH) 438.4 x 590 x 43.5 mm (17.26 x 23.23 x 1.71 in.)
- **Weight** 11.85 kg (26.12 lb), with 2 PSUs and 6 fans installed
- **Temperature Operating** (F2B): 0° C to 45° C (32° F to 113° F)
 - **Operating** (B2F): 0° C to 35° C (32° F to 95° F)
 - **Storage**: -40° C to 70° C (-40° F to 158° F)
- **Humidity Operating**: 5% to 95% (non-condensing)
- **Power Consumption**
 - Min. (w/o transceivers): 396 W @ 100 VAC / 386 W @ 240 VAC
 - Max. (w/o transceivers): 714 W @ 100 VAC / 653 W @ 240 VAC

AC PSU

- **Input Power Rating**
 - 100–127 VAC, 50/60 Hz, 12 A max. (1000 W max.)
 - 220–240 VAC, 50/60 Hz, 8 A max. (1500 W max.)
 - 210–310 VDC, 8.5–6 A

DC PSU

- **Power Rating** -48 VDC, 1600 Watts
- **DC Input** -40 V – -75 V, 40 A maximum

Regulatory Compliances

- **Emissions**
 - EN 55032 Class A
 - EN 61000-3-2
 - EN 61000-3-3
 - CNS 15936 Class A
 - VCCI-CISPR 32 Class A
 - AS/NZS CISPR 32 Class A
 - ICES-003 Issue 7 Class A
 - FCC Class A
- **Immunity**
 - EN 55035
 - EN 55024
 - IEC 61000-4-2/3/4/5/6/8/11
- **Safety**
 - UL (CSA 22.2 No 62368-1 & UL62368-1)
 - CB (IEC/EN 62368-1)

- CNS15598-1

www.edge-core.com

Documents / Resources

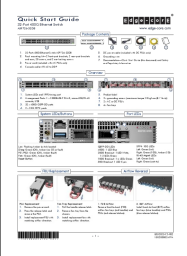
	<p>Edgecore Networks AS9726-32DB 32 Port 400G Ethernet Switch [pdf] User Guide AS9726-32DB 32-Port 400G Ethernet Switch, AS9726-32DB, 32-Port 400G Ethernet Switch, 400G Ethernet Switch, Ethernet Switch, Switch</p>
---	---

References

- [Edgecore Networks – Edgecore Networks, a leading provider of traditional and open network solutions, delivers wired and wireless networking products and solutions through channel partners and system integrators worldwide for data center, service provider.](#)
- [User Manual](#)

[Manuals+](#), [Privacy Policy](#)

This website is an independent publication and is neither affiliated with nor endorsed by any of the trademark owners. The "Bluetooth®" word mark and logos are registered trademarks owned by Bluetooth SIG, Inc. The "Wi-Fi®" word mark and logos are registered trademarks owned by the Wi-Fi Alliance. Any use of these marks on this website does not imply any affiliation with or endorsement.