



Dwyer WHT Series Weather-Proof Humidity/Temperature Transmitter Instruction Manual

[Home](#) » [Dwyer](#) » Dwyer WHT Series Weather-Proof Humidity/Temperature Transmitter Instruction Manual 

Contents

- [1 Dwyer WHT Series Weather-Proof Humidity/Temperature Transmitter](#)
- [2 Specifications – Installation and Operating Instructions](#)
- [3 SPECIFICATIONS](#)
- [4 MAINTENANCE](#)
- [5 Documents / Resources](#)
 - [5.1 References](#)
- [6 Related Posts](#)



Dwyer WHT Series Weather-Proof Humidity/Temperature Transmitter



Specifications – Installation and Operating Instructions

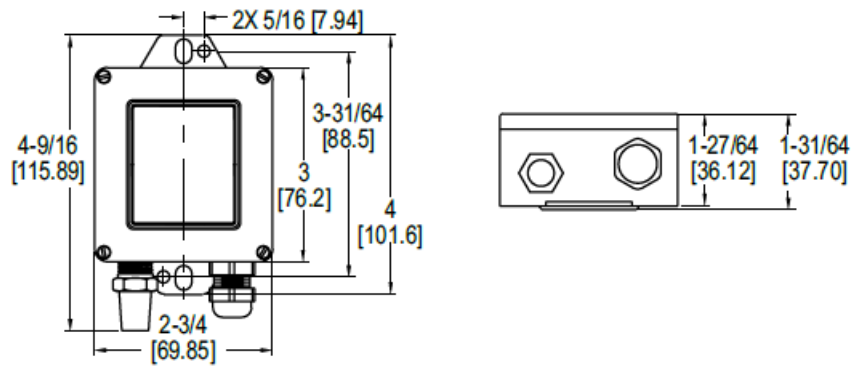

The Compact Series WHT Weather-Proof Humidity/Temperature Transmitter is designed to withstand the elements. A removable sintered filter protects the polymer capacitance sensor from solid objects that may come in contact with the transmitter. The transmitter is available with 4-20 mA, or 0-10 VDC or 0-5 V output signals for both temperature and humidity or a passive thermistor for temperature. This transmitter is ideal for measuring outside air temperature and humidity levels for air handling economizer applications.

INSTALLATION

Warning: Disconnect the power supply before installation to prevent electrical shock and equipment damage.

CAUTION

Make sure all connections are in accordance with the job wiring diagram and in accordance with national and local electrical codes. Use copper conductors only. Use electrostatic discharge precautions (e.g., use of wrist straps) during installation and wiring to prevent equipment damage. Avoid locations where severe shock or vibration, excessive moisture or corrosive fumes are present. NEMA Type 3S (IP54) housings are intended for outdoor use primarily to provide a degree of protection against wind-blown dust, and rain. Do not exceed the ratings of this device, permanent damage not covered by warranty may result. The 4 to 20 mA models are not designed for AC voltage operation.

SPECIFICATIONS

- Relative Humidity Range: 0 to 100% RH.
- Temperature Range: -40 to 140°F (-40 to 60°C).
- Accuracy, RH: $\pm 3\%$ 20 to 80% RH, $\pm 4\%$ @ 10-20%, 80 to 90%.
- Accuracy, Temp Models with 4-20 mA Temp. Output: $\pm 0.9^\circ\text{F}$ @ 72°F ($\pm 0.3^\circ\text{C}$ @ 25°C).
- Accuracy, Temp Models with Passive Thermistor Temp Sensor: $\pm 0.36^\circ\text{F}$ @ 77°F ($\pm 0.2^\circ\text{C}$ @ 25°C).
- Hysteresis, RH: $\pm 1\%$.
- Repeatability, RH: $\pm 0.1\%$ typical.
- Temperature Limits: -40 to 140°F (-40 to 60°C).
- Storage Temperature: -40 to 176°F (-40 to 80°C).
- Compensated Temperature Range, RH: -4 to 140°F (-20 to 60°C).
- Power Requirements: 4-20 mA loop powered models: 10-35 VDC; 0-10 V output models: 15-35 VDC or 15-29 VAC; 0-5 V output models: 10-35 VDC or 10-29 VAC. Output Signal: 4-20 mA loop powered models: 4-20 mA; 0-10 V output models: 0-10 V @ 5 mA max; 0-5 V output models: 0-5 V @ 5 mA max.
- Response Time: 15 s.
- Electrical Connections: Removable screw terminal block.
- Drift: $<1\%$ RH/year.
- RH Sensor: Capacitance polymer.

- Temperature Sensor: 4-20 mA output, solid-state band gap. Passive output: 10K @ 25°C thermistors (Dwyer curve A).
- Enclosure: ABS.
- Enclosure Rating: Designed to meet NEMA 3S (IP54).
- Weight: 0.3 oz (8.5 g).
- Agency Approvals: CE.

MOUNTING

The transmitter should be mounted with the sensor pointing downward to prevent water collection in the housing. The integral mounting tab has two sets of mounting holes. The larger holes are for the suspension mounting and the smaller holes are for surface mounting the transmitter to a wall. Please see Figures 1 and 2 for more information on both mounting methods.

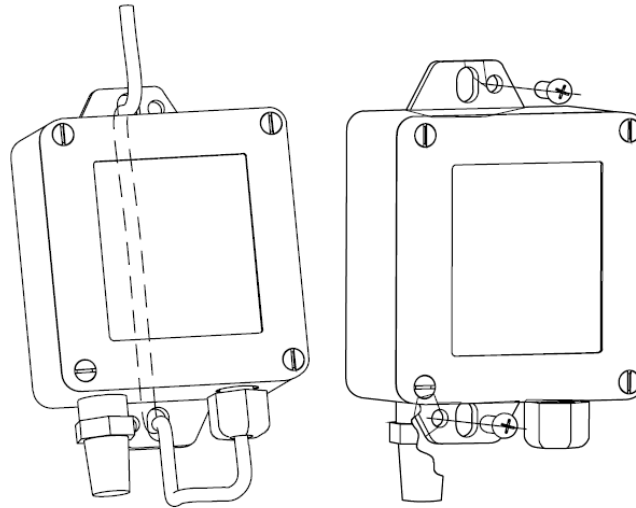

Figure 1: Suspension mounting

Figure 2: Surface mounting

WIRING

Use a maximum 18 AWG wire for the wiring terminal. Refer to Figures 3-6 for wiring information. Models with 4-20 mA RH Output, with or without 4-20 mA Temperature Output 4-20 mA output units may be powered with a 10-35 VDC supply. The following describes the proper wiring of these transmitters with mA output. Models with 4-20 mA RH and 4-20 mA Temperature outputs are designed as a 4-20 mA devices with two channels. The channels are common on the positive side of the current loop. Sensor excitation is derived from the relative humidity channel, so power must always be applied to that channel. If the temperature channel is not equipped or used, it can be left disconnected. Wire as shown in Figure 3.

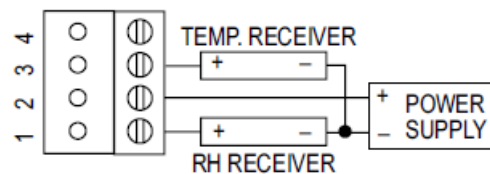

Figure 3

Models with 4 to 20mA RH Output and a Passive Thermistor Temperature Sensor The 4-20 mA RH output is identical to the above model with a 4-20 mA temperature output. The required power supply and wiring of the RH output is the same. The passive thermistor temperature sensor wires to terminals 3 and 4. Wire as shown in Figure 4.

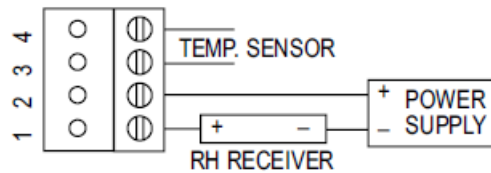

Figure 4

Models with 0-5 V or 0-10 V RH Output, with or without 0-5 V or 0-10 V Temperature Output

The 0 to 10 V output models may be powered with 15-35 VDC or 15-29 VAC. The 0-5 V models may be powered with 10-35 VDC or 10-29 VAC. Note the polarity when using DC power. The channels are common on the negative side. For RH and Temperature outputs, either or both may be used. The maximum load is 5 mA (1K for 0 to 5 V, 2K for 0 to 10 V). Wire as shown in Figure 5.

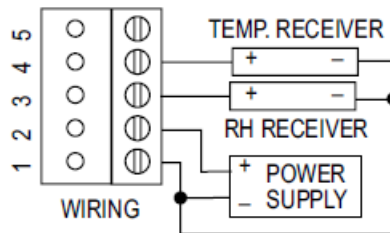

Figure 5

Models with 0-5 or 0 to 10 V RH Output and a Passive Thermistor Temperature Sensor

The 0 to 5 V or 0 to 10 V RH output is identical to the above model with a 0-5 V or 0-10 V temperature output. The required power supply and wiring of the RH output is the same. The passive thermistor temperature sensor wires to terminals 4 and 5. Wire as shown in Figure 6.

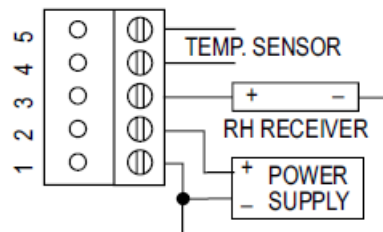

Figure 6

Checkout 4-20 mA Models

Verify appropriate supply voltage. The transmitter requires a minimum of 10 and a maximum of 35 VDC at its connection for proper operation. Choose a power supply with a voltage and current rating which meets this requirement under all operating conditions. If the power supply is unregulated, make sure voltage remains within these limits under all power line conditions. The ripple on the supply should not exceed 100 mV. Loop Resistance – The maximum allowable loop resistance depends on the power supply voltage. Maximum loop voltage drop must not reduce the transmitter voltage below the 10 VDC minimum. Maximum loop resistance can be calculated with the following equation. V_{ps} is the power supply voltage.

$$R_{max} = \frac{V_{ps} - 10.0}{20 \text{ mA}}$$

Some receivers, particularly loop-powered indicators, may maintain a fixed loop voltage to power the device. This voltage drop must also be subtracted from the power supply voltage when calculating the voltage margin for the transmitter. The following equation takes this into account. V_{rec} is the receiver's fixed voltage.

$$R_{max} = \frac{V_{ps} - 10.0 - V_{rec}}{20 \text{ mA}}$$

0-5, 0 to 10 V Output Models

Verify appropriate supply voltage. The 0-10 V output models require a DC supply of 15-35 V or an AC supply of 15-29 V for proper operation maximum. The 0-5 V output models require a DC supply of 10-35 V or an AC supply of 10-29 VAC. Both outputs may be loaded simultaneously with 5 mA.



MAINTENANCE

Upon final installation of the Series WHT Temperature/Humidity Transmitter and the companion receiver, no routine maintenance is required. A periodic check of the system calibration is recommended. The Series WHT is not fielded serviceable and should be returned if repair is needed (field repair should not be attempted and may void the warranty). Be sure to include a brief description of the problem plus any relevant application notes. Contact customer service to receive a return goods authorization number before shipping. This symbol indicates waste electrical products should not be disposed of with household waste. Please recycle where facilities exist. Check with your Local Authority or retailer for recycling advice. DWYER INSTRUMENTS, INC.

P.O. BOX 373 • MICHIGAN CITY, INDIANA 46360, U.S.A. Phone: 219-879-8000 Fax: 219-872-9057 www.dwyer-inst.com

e-mail: info@dwyermail.com

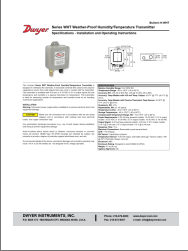
Documents / Resources

	<p>Dwyer WHT Series Weather-Proof Humidity/Temperature Transmitter [pdf] Instruction Manual</p> <p>WHT Series Weather-Proof Humidity Temperature Transmitter, WHT Series Weather-Proof Humidity, WHT Series Temperature Transmitter, Weather Proof Humidity Temperature Transmitter, Temperature Transmitter, Humidity Transmitter, Transmitter</p>
	<p>Dwyer WHT Series Weather-Proof Humidity/Temperature Transmitter [pdf] Instruction Manual</p> <p>WHT Series Weather-Proof Humidity Temperature Transmitter, WHT Series Weather-Proof Humidity, WHT Series Temperature Transmitter, Temperature Transmitter, Transmitter, Weather Proof Humidity Transmitter</p>

References

- [Dwyer Home](#)