



COMET SYSTEM DigiS/E Humidity Temperature Probe Instruction Manual

[Home](#) » [COMET SYSTEM](#) » COMET SYSTEM DigiS/E Humidity Temperature Probe Instruction Manual 



DigiS/E
humidity-temperature probe

Contents

- [1 PRODUCT DESCRIPTION](#)
- [2 TECHNICAL PARAMETERS](#)
- [3 DIMENSIONS](#)
- [4 INSTALLATION](#)
- [5 TECHNICAL SUPPORT AND SERVICE](#)
- [6 Warranty certificate](#)
- [7 Documents / Resources](#)
 - [7.1 References](#)

PRODUCT DESCRIPTION

DigiS/E probe with the I²C output is designed to measure air temperature and relative humidity in chemically non-aggressive environments. It is designed for connection to COMET devices equipped with inputs for Digi/E series probes. The probe is interchangeable, the calibration constants are saved in the internal memory of the probe. This probe cannot be connected to devices with analog inputs, for example a Pt1000 temperature probe. The probe is suitable for applications with required fast response time.

TECHNICAL PARAMETERS

- **Temperature**

Range:	-20 to +80 °C
Accuracy:	± 0.4 °C
Response time:	t90 < 1 min (temperature step 20 °C, air flow 1 m/s)

• **Relative humidity**

Range:	0 to 100 %RH (without condensation)
Accuracy of the humidity sensor:	±1.8 %RH in the range of 0 to 90 %RH at 23 °C
Hysteresis:	< ±1 %RH
Linearity error:	< ±1 %RH
Temperature error:	0,05 % RH/°C (0 °C to +60 °C)
Response time:	t90 < 6 s (humidity step 60 %RH, constant temperature)

• **Calculated humidity quantities**

1/ Dew point temperature	
Range:	-60 to +80 °C

Accuracy:

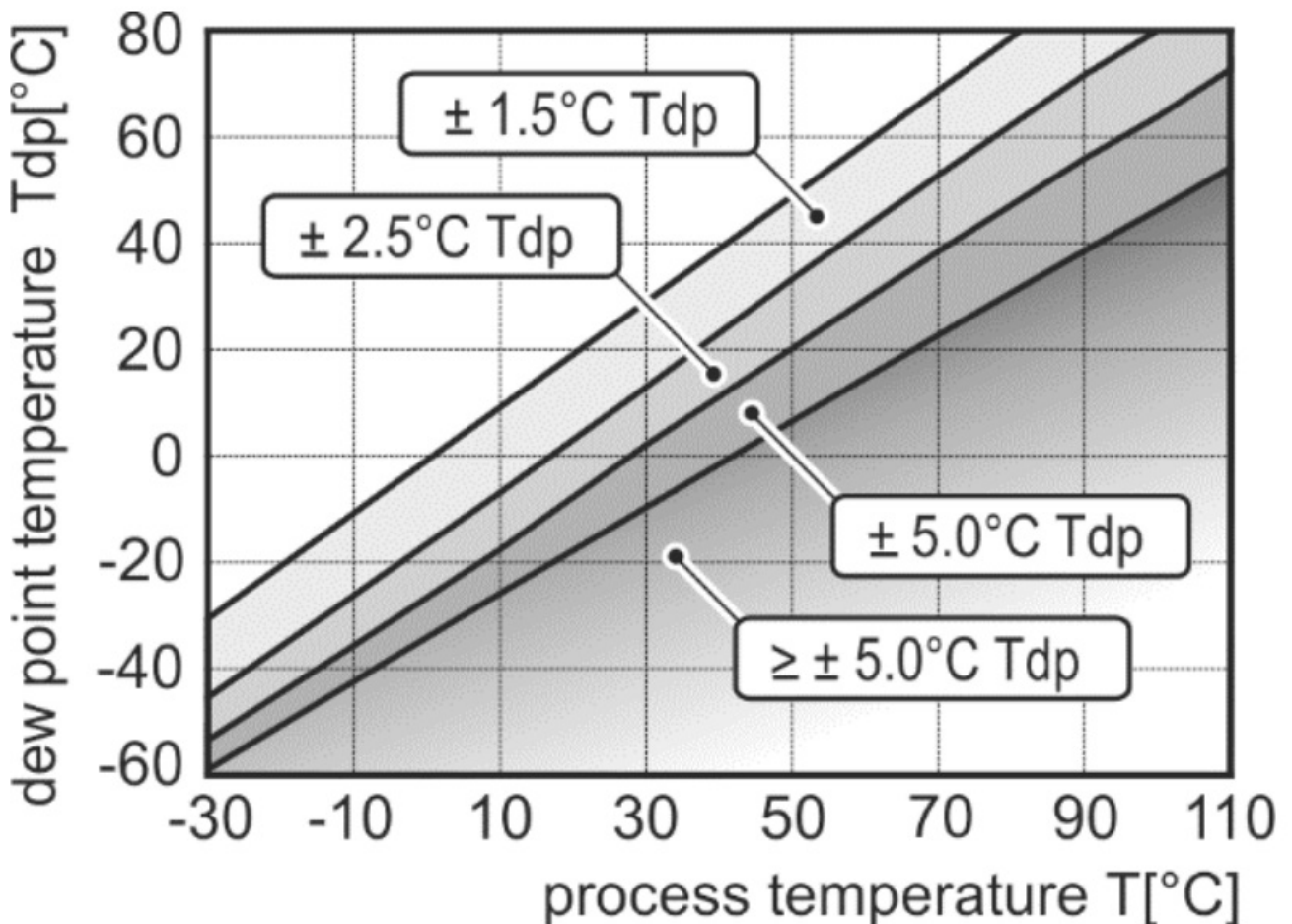

2/ Absolute humidity	
Range:	0 to 130 g/m ³
Accuracy:	±1.5 g/m ³ for ambient temperature T < 25 °C
3/ Specific humidity	
Range:	0 to 130 g/kg
Accuracy:	±2 g/kg for ambient temperature T < 35 °C and atmospheric pressure of 1013 hPa
4/ Mixing ratio	
Range:	0 to 130 g/kg
Accuracy:	±2 g/kg for ambient temperature T < 35 °C and atmospheric pressure of 1013 hPa
4/ Mixing ratio	
Range:	0 to 150 g/kg
Accuracy:	±2 g/kg for ambient temperature T < 35 °C and atmospheric pressure of 1013 hPa
5/ Specific enthalpy	
Range:	0 to 450 kJ/kg
Accuracy:	±5 kJ/kg for ambient temperature T < 35 °C and atmospheric pressure of 1013 hPa

- Operating temperature range: -20 to +80 °C
Operating relative humidity range: 5 to 85 %RH for continuous operation
- Power: 2.7 to 5.5 V
Current consumption: 50 µA @ 5 V
- Recommended calibration interval: 1 year
- Storage temperature: -20 to +80 °C
Storage relative humidity: 0 to 95 %RH (without condensation)
- **Electromagnetic compatibility:**
EN 61326-1 (tested with device)
Emission: EN 55011, class B
- **Immunity:**
EN 61000-4-2, 4 kV/8 kV, class A
EN 61000-4-3, 3 V/m, class A
- Protection: IP30
Working position: without restriction
Weight: approximately 6 g ”
Material: ABS

DIMENSIONS

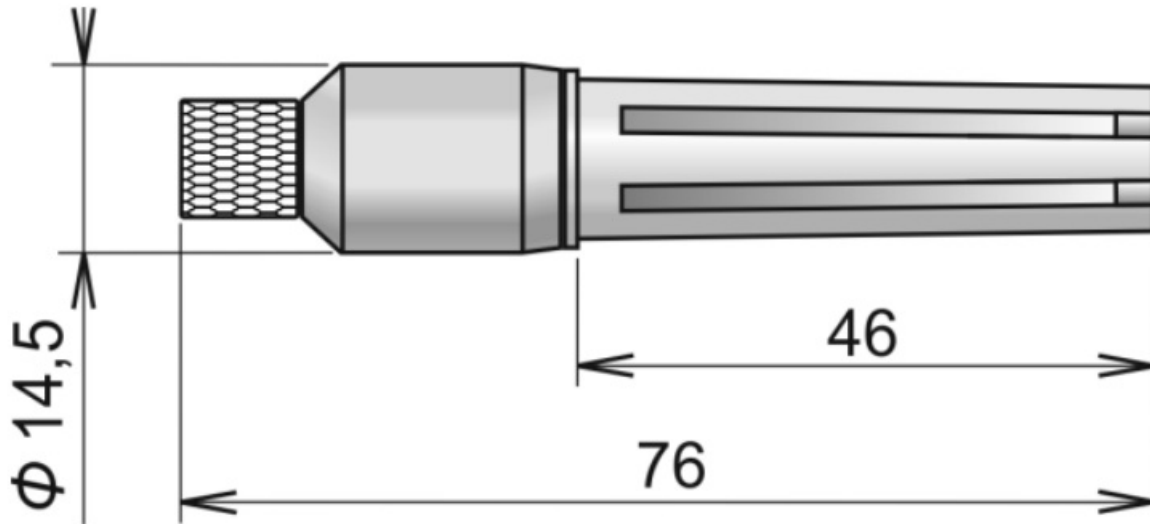

INSTALLATION

- to devices series Uxxxx and Wx7xx connect the probe directly or use an extension cable SDP001 (see optional accessories)
- do not connect the probe directly to the devices series Wx8xx, always use an SDP001 extension cable with a minimum length of 1 m
- if the probe is connected to the measuring device directly (without an extension cable), do not exceed the operating temperature of the device

The probe does not require any special service or maintenance. We recommend periodic calibration for measurement accuracy validation.

TECHNICAL SUPPORT AND SERVICE

Technical support and service is provided by distributor. For contact see warranty certificate. If needed, you can also use the discussion forum at <http://www.forum.cometsystem.cz/>.



WARNING

- It is not recommended to use the probe for long time in a dusty environment.
- It is not recommended to use the probe for long time under condensation conditions.
- Don't connect or disconnect the probe cable while device is turned on – incorrect values could be recorded in the memory of the device.
- The probe contains electronic components; it needs to liquidate them according to legal requirements.

Warranty certificate

This product has three years warranty since the date of sale to the end user. Defects due defective materials, defective manufacturing or design will be repaired free of charge by the manufacturer.

The location of repair is at manufacturer's. No warranty is given to products operated in conditions not matching the conditions specified by the manufacturer in instruction manual. Also no warranty is given to products which were modified by the user, products with broken seal, products which were connected to power or input signals not matching the technical specification (Instruction manual). No warranty is given to consumables, e.g. batteries, fuses and eventual changes of parameters created by wear (influence of aggressive environment etc.)

Serial number:DISTRIBUTOR

Sale date:.....

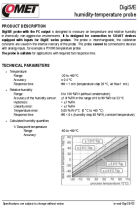

Documents / Resources

	<p>COMET SYSTEM DigiS/E Humidity Temperature Probe [pdf] Instruction Manual DigiS E Humidity Temperature Probe, DigiS E, Humidity Temperature Probe, Temperature Probe, Probe</p>
---	---

References

- [Comet system forum](#)

[Manuals+](#).