



cell2 MS3 Surface Mount User Manual

[Home](#) » [Cell2](#) » cell2 MS3 Surface Mount User Manual 

Contents

- [1 cell2 MS3 Surface Mount](#)
- [2 Surface Mount](#)
- [3 Adhesive Mount](#)
- [4 Screw Mount](#)
- [5 Bracket Mount](#)
- [6 Documents / Resources](#)
 - [6.1 References](#)
- [7 Related Posts](#)



cell2 MS3 Surface Mount



Surface Mount

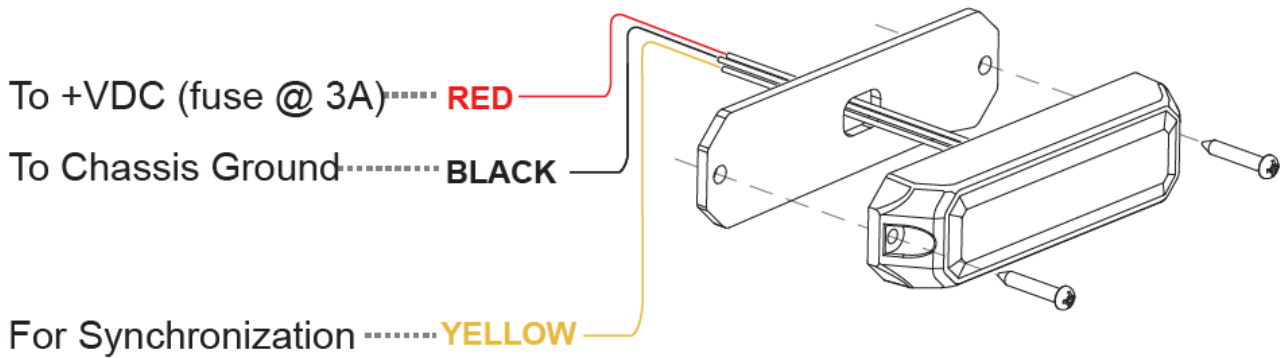

Connect YELLOW wires of all heads together for synchronization (All heads must be set at the same pattern)

For Simultaneous or Alternating Flash

1. Apply +VDC to RED and YELLOW wires simultaneously to enter Grouping mode; lighthouse will display short (single or double) flashes:
 1. Single flash = Group1
 2. Double flash = Group2
2. Remove YELLOW wire from +VDC and momentarily apply to +VDC to change Groups:
 1. Heads in the same Group flash together.
 2. Group1 Heads alternate with Group2 Heads

For Flash Patterns:

Momentarily apply +VDC to YELLOW wire:

- once for next pattern
- quickly three times for pattern 0

FP#	Flash Patterns		
0	Random	6	Quad
1	Single	7	Quint
2	Single	8	8 Flash
3	Mega	9	Single-Quad
4	Double	10	Single H/L
5	Triple	11	Single-Triple-Quint

NOTE: This unit may not be factory set at FP# 0.

Adhesive Mount

1. Select mounting location and clean surface.
2. Peel one side of adhesive and apply to lighthouse base.
3. Peel other side of adhesive and secure lighthouse firmly to the mounting surface

NOTE: Optimum adhesive strength is achieved after 24hrs

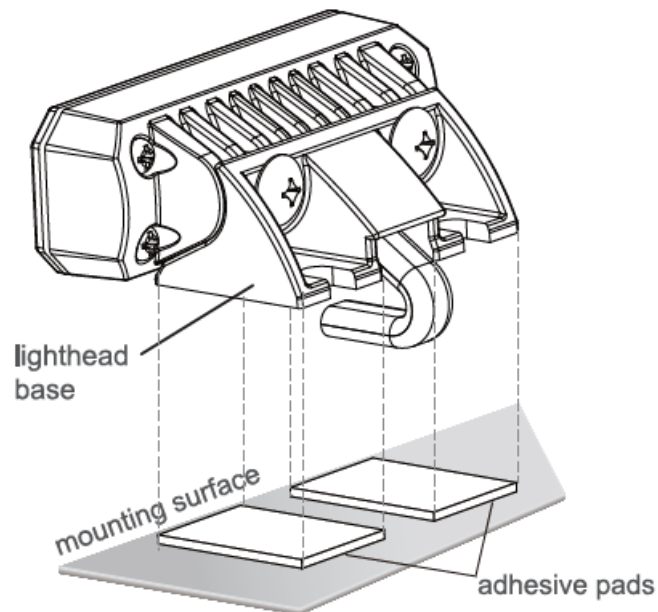

Screw Mount

1. Select a mounting location.
2. Mark and drill mounting holes.
3. Place the rubber pad to the bottom of the lighted base.
4. Secure light head to the mounting surface with supplied screws

supplied screws.

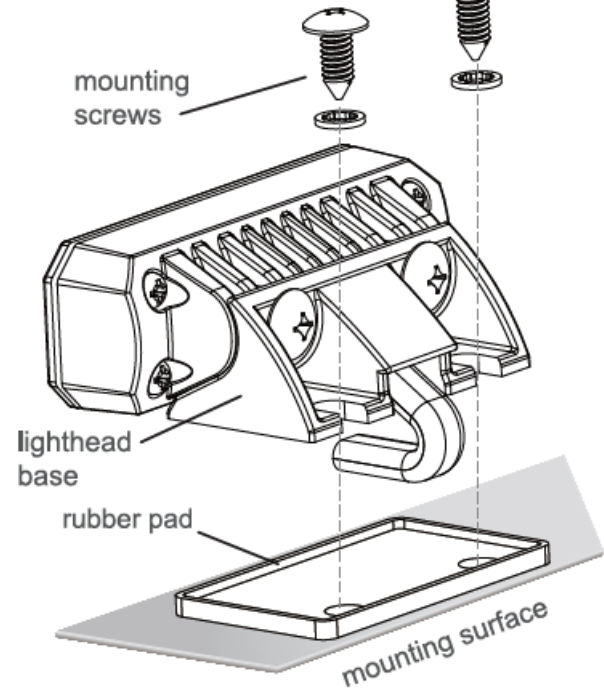

Bracket Mount

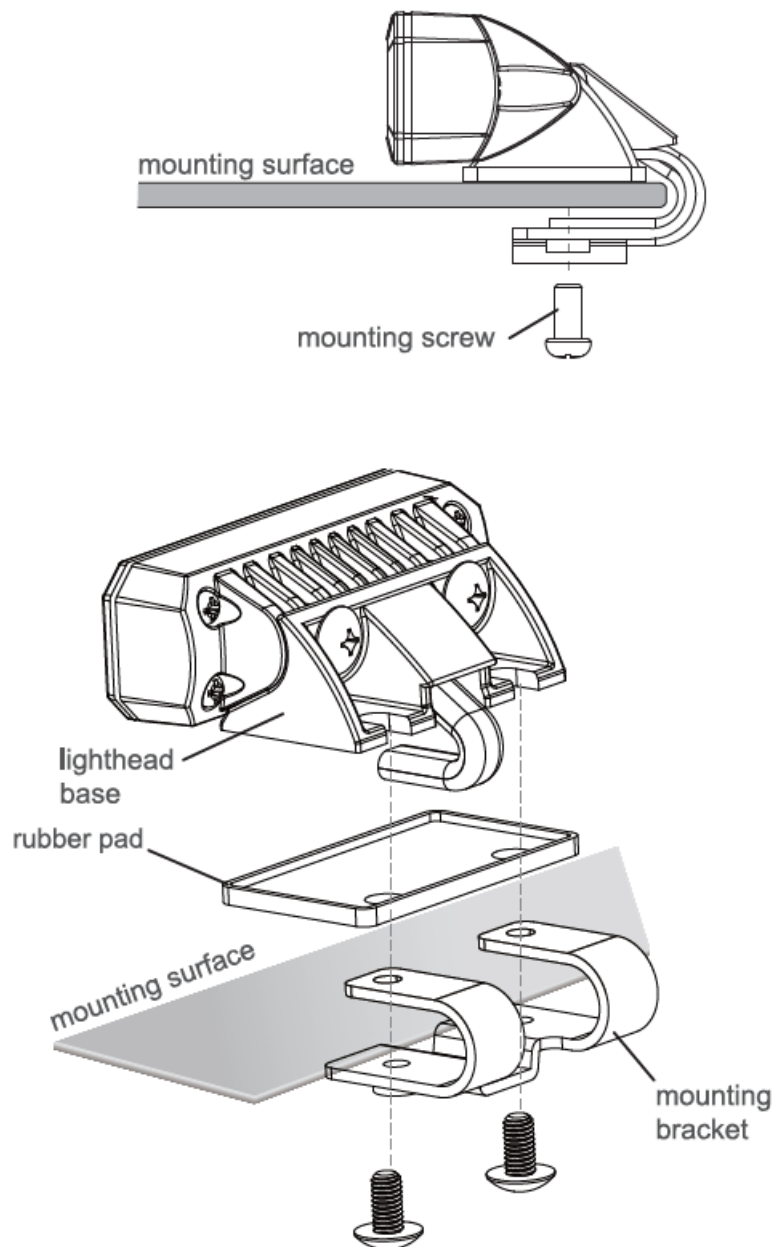

1. Select a mounting location.
2. Place the rubber pad to the bottom of the lighted base.
3. Place light head to the mounting surface.
4. Align top holes of the bracket onto the lighted base alignment points.
5. Secure lightheaded with supplied screws from the bottom of the bracket

Unit 4 Premus, Brunel Park, Coldharbour Way Aylesbury, Buckinghamshire HP19 8AP
web: www.cell2.com email: sales@cell2.com tel : +44(0)2033 285 494

Documents / Resources

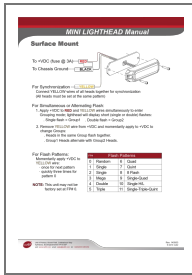

[cell2 MS3 Surface Mount](#) [pdf] User Manual
MS3 Surface Mount, MS3, Surface Mount, Mount

References

- [Visual & Audible Warning Systems - Cell2](#)

Manuals+.