

CAFE
CXE22DP2PS1 Anti
Tip Floor Bracket



CAFE CXE22DP2PS1 Anti Tip Floor Bracket Installation Guide

[Home](#) » [Cafe](#) » CAFE CXE22DP2PS1 Anti Tip Floor Bracket Installation Guide 

Contents

- [1 CAFE CXE22DP2PS1 Anti-Tip Floor Bracket](#)
- [2 MATERIALS YOU MAY NEED \(not included\)](#)
- [3 TOOLS YOU WILL NEED](#)
- [4 LOCATING THE ANTI-TIP FLOOR BRACKET \(cont.\)](#)
- [5 Documents / Resources](#)
 - [5.1 References](#)

CAFE

CAFE CXE22DP2PS1 Anti-Tip Floor Bracket



WARNING

Tip Over Hazard.



Built-in style models (models PHD, PJD, PJE, PXD, CJE, CHE, and CXE) are top-heavy, especially with any doors open. These models must be secured with the anti-tip floor bracket to prevent tipping forward, which could result in death or serious injury. Read and follow the entire installation instructions for installing the anti-tip floor bracket packed with your refrigerator.

NOTE

If you did not receive an anti-tip bracket with your purchase, call 1.800.GECARES to receive one at no cost. (In Canada, call 1.800.561.3344.) For installation instructions for the bracket, visit www.GEAppliances.com. (In Canada, www.GEAppliances.ca.)

MATERIALS YOU MAY NEED (not included)

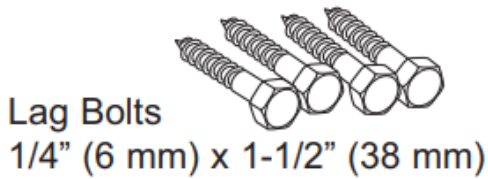

Drill Bit Appropriate for Anchors
For Anti-Tip Bracket Mounted on CONCRETE Floors Only

MEASURE CABINET OPENING AVAILABLE VS. REFRIGERATOR WIDTH

Measure the width of the cabinet opening where the refrigerator will be placed, W. Be sure to account for any countertop overhang, baseboard thickness, and any clearance desired. Width, W, should not be less than 36". The refrigerator will be placed approximately in the middle of this opening.

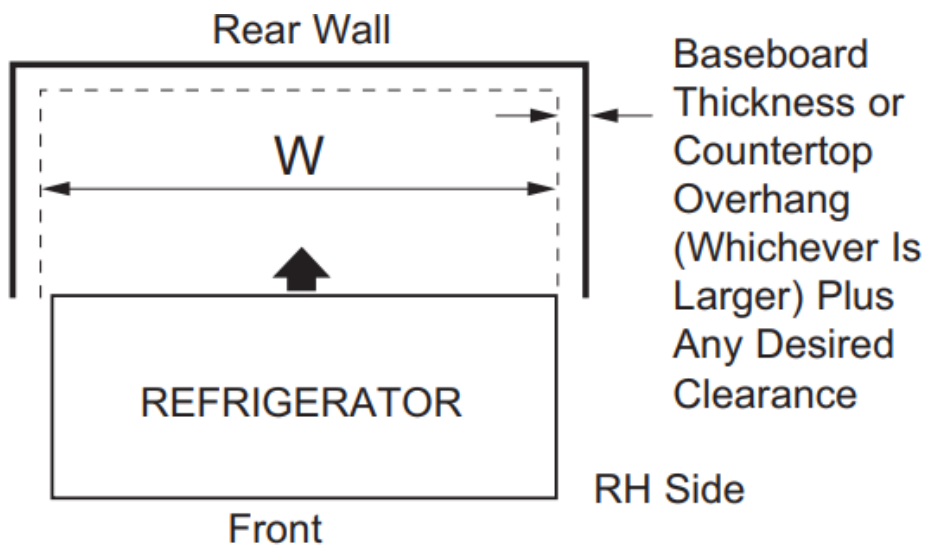

TOOLS YOU WILL NEED

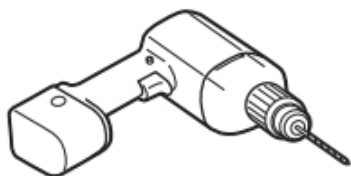

1/8" (3 mm) Drill Bit and Electric or Hand Drill

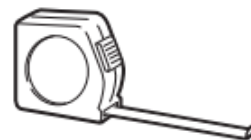

Tape measure



Pencil



5/16" (8 mm) Nut Driver

LOCATING THE ANTI-TIP FLOOR BRACKET

Place the anti-tip floor bracket locator template (included inside the anti-tip kit) onto the floor up against the rear wall, within W, and in line with the desired location of the RH side of the refrigerator (see Figure 1).

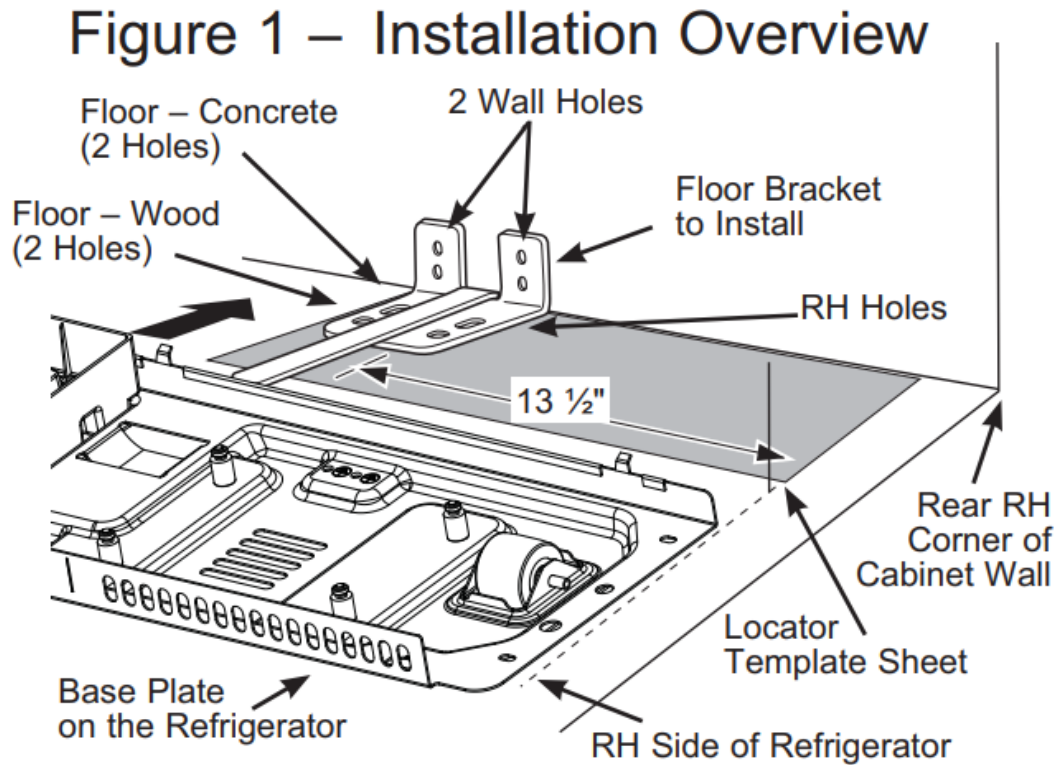

Figure 1 – Installation Overview

Place the anti-tip floor bracket onto the locator template with its RH floor holes lined up with the floor holes indicated on the template sheet, approximately 13 1/2" from the edge of the sheet or the RH side of the refrigerator. Hold down in position and use the anti-tip floor bracket as a template for marking the holes based on your configuration and type of construction as shown in Step 3. Mark the hole locations with a pencil, nail, or awl.

NOTE

It is **REQUIRED** to use at least 2 screws to mount the floor bracket (one on each side of the anti-tip floor bracket). Both must be on either the wall or the floor. Figure 2 indicates all the acceptable mounting configurations for screws. Identify the screw holes on the anti-tip floor bracket for your configuration.

LOCATING THE ANTI-TIP FLOOR BRACKET (cont.)

Figure 2 – Acceptable Screw Placement Locations

Recommended Installation
– Wood

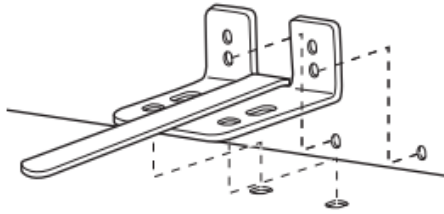

Recommended Installation
– Concrete

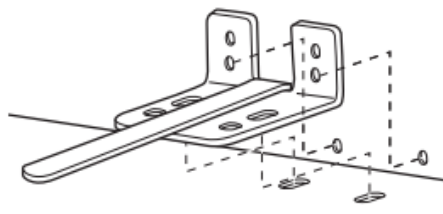

Minimum Acceptable #1 –
Wall Plate Stud

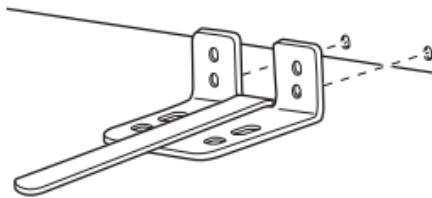

Minimum Acceptable #2
– Wood Floor

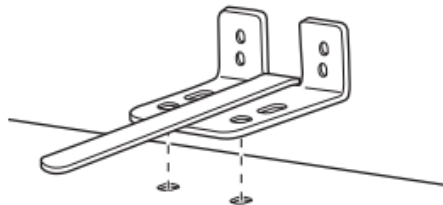

Minimum Acceptable #3
– Concrete Floor

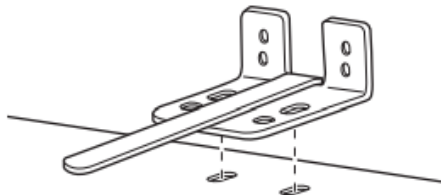

ANTI-TIP BRACKET INSTALLATION

WOOD Wall and Floor Construction:

- Drill the appropriate number of 1/8" (3 mm) pilot holes in the center of each floor bracket hole being used (a nail or awl may be used if a drill is not available) AND remove the locator template from the floor.

Figure 3 – Attachment to Wall and Floor

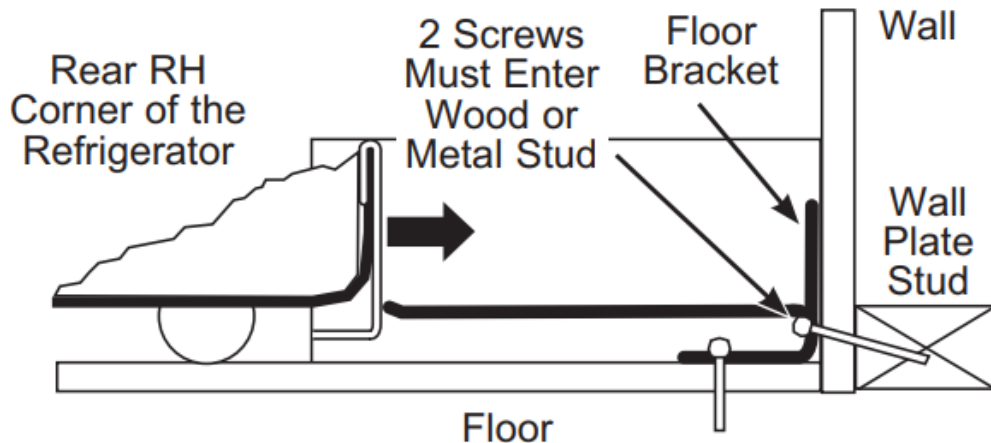

- Mount the anti-tip floor bracket by fastening the 2, or recommended 4, #10 screws included, tightly into place as illustrated in Figure 3.

CONCRETE Wall and Floor Construction

- Anchors required (not provided): 4 each 1/4" (6 mm) x 1-1/2" (38 mm) lag bolts 4 each 1/2" (12 mm) O.D. sleeve anchors
- Drill the recommended size holes for the anchors into the concrete at the center of the holes marked in Step 2.
- Install the sleeve anchors into the drilled holes. Place the anti-tip floor bracket as indicated in Step
- Remove the locator template from the floor.
- install the lag bolts through the anti-tip floor bracket and tighten them appropriately. WOOD Wall and TILE Floor Construction:
- For this special case, locate the 2 wall holes identified in Fig. 2. Drill an angled 1/8" (3 mm) pilot hole (approx. as shown in Fig. 3) in the center of each hole.
- Mount the anti-tip floor bracket using the Minimum Acceptable Installation #1, as illustrated in Fig. 2.

POSITIONING THE REFRIGERATOR TO ENGAGE THE ANTI-TIP FLOOR AND BASE BRACKETS

Before pushing the refrigerator into the opening, plug the power cord into the receptacle and connect the waterline (if equipped). Check for leaks. Locate the refrigerator's RH side and move back approximately in line with the RH side of the cabinet opening, W. This should position the anti-tip floor bracket to engage the anti-tip base bracket on the refrigerator.

Gently roll the refrigerator back into the cabinet opening until it comes to a complete stop. Check to see if the refrigerator front lines up with the cabinet front face. If not, carefully rock the refrigerator forward and backward until engagement occurs and you notice that the refrigerator is fully pushed up against the rear wall. If Applicable: Adjust the rear (and front) wheel height settings to fully engage the rear anti-tip brackets, while also aligning the refrigerator's front with the cabinet's front face.

NOTE

If you pull the refrigerator out and away from the wall for any reason, make sure the anti-tip floor bracket is engaged when the refrigerator is pushed back against the rear wall.

Documents / Resources



[CAFE CXE22DP2PS1 Anti Tip Floor Bracket](#) [pdf] Installation Guide
CXE22DP2PS1 Anti Tip Floor Bracket, CXE22DP2PS1, Anti Tip Floor Bracket, Floor Bracket, B
racket

References

- [User Manual](#)

[Manuals+](#), [Privacy Policy](#)

This website is an independent publication and is neither affiliated with nor endorsed by any of the trademark owners. The "Bluetooth®" word mark and logos are registered trademarks owned by Bluetooth SIG, Inc. The "Wi-Fi®" word mark and logos are registered trademarks owned by the Wi-Fi Alliance. Any use of these marks on this website does not imply any affiliation with or endorsement.